



# National Institute of Standards & Technology

## Certificate

### Standard Reference Material 1972

#### 1,3-Dioxolan-2-one (Ethylene Carbonate) Triple-Point Standard

#### International Temperature Scale of 1990 (ITS-90)

This Standard Reference Material (SRM) is intended to be used to calibrate thermometers near 36.314 °C. Any thermometer smaller than about 4.5 mm in diameter can be inserted into this SRM and can be calibrated if the sensor is such that its immersion is adequate. SRM 1972 consists of approximately 60 g of ethylene carbonate, which is estimated to be 99.999% to 99.9999% pure, sealed under vacuum in a borosilicate glass tube containing a re-entrant thermometer well. The certified temperature is on the ITS-90. It is the temperature obtained for this material during freezing experiments in which the "mush" technique was used. The temperature of the freeze was determined by the use of one or more stable thermistor thermometers which had been calibrated by comparison with a Standard Platinum Resistance Thermometer (SPRT). The SPRT had been calibrated on the International Practical Temperature Scale of 1968 at the National Institute of Standards and Technology (NIST) and the temperatures of that calibration converted to the ITS-90.

Certified Triple-Point Temperature:  $36.3143 \pm 0.0015$  °C

The stated uncertainty ( $2\sigma$ ) of 0.0015 °C represents the total uncertainty attributed to: calibration of the SPRT on the IPTS-68 and converted to the ITS-90; calibration of the thermistor thermometer against the SPRT; the irreproducibility of the freezing-point temperature of a given ethylene carbonate cell; and the scatter of the freezing-point temperature among all of the ethylene carbonate cells.

#### Description of SRM 1972

Figure 1 is a cross-sectional drawing of the ethylene carbonate triple-point cell.

SRM 1972 was designed and developed by B.W. Mangum. The glass cells were fabricated in the NIST Scientific Instrument Shop by J.R. Anderson. The ethylene carbonate was purified, and the cells were filled and sealed at Rensselaer Polytechnic Institute, Troy, NY, by Prof. M.E. Glicksman and his students.

The technical measurements leading to certification of SRM 1972 were performed by B.W. Mangum of the Thermometry Group of the NIST Process Measurements Division.

The support aspects involved in the issuance of this SRM were coordinated through the Standard Reference Materials Program by J.C. Colbert.

Gaithersburg, MD 20899  
May 26, 1994

Thomas E. Gills, Chief  
Standard Reference Materials Program

(over)

**Instructions for Use:** SRM 1972 should be used as a calibrant in a temperature-regulated bath. A low viscosity fluid with a low vapor pressure, e.g., a light purified mineral oil, should be put in the thermometer well of the cell to provide thermal contact between the thermometer being calibrated and the ethylene carbonate. The thermometer should be fully inserted into the thermometer well of the cell so that it rests on the bottom of the well. The entire cell, including the thermometer-well extension tube, should be immersed in the temperature-regulated environment (e.g., a well-stirred liquid bath) during calibration of thermometers. If that is not practicable, a short section of the thermometer-well extension tube may be exposed to the external environment. A (temperature-regulated) liquid bath is not required for proper operation of SRM 1972, but some type of temperature-regulated environment is required.

In preparing SRM 1972 for use:

1. Melt all of the ethylene carbonate by completely immersing the main part of the cell, i.e., all of the cell except the thermometer-well extension tube, in a liquid bath at about 75 °C. (Partial immersion may cause breakage of the glass walls of the cell.)
2. When the ethylene carbonate has completely melted, remove the cell from the bath, thoroughly mix the molten material by inverting the cell several times. **NOTE: Hold the main part of the cell, not the thermometer-well extension, during this exercise.**
3. Place the cell in a container of water at a temperature of about 20 °C to supercool. **DO NOT LET ANY WATER GET INTO THE RE-ENTRANT WELL.** When the ethylene carbonate has cooled to a temperature of about 20 °C to 25 °C, remove the cell from the water, dry the outside of the cell, and nucleate the freeze by directing a jet of a refrigerant, such as Quik Freeze, against the cell near its bottom for one or two seconds. Once the freeze has nucleated, dendritic growth will proceed rapidly throughout the sample. Then, fill the re-entrant well, (the thermometer well), to the top of the extension tube with a light mineral oil whose temperature is about 20 °C. Place the cell in a temperature-regulated environment (e.g., oil bath) at a temperature of about  $35.90 \pm 0.10$  °C on the ITS-90. Insert the thermometer to be calibrated (pre-warmed to about 35 °C).
4. After about 45 min have elapsed, proceed with the calibration of the thermometer. With the bath temperature set at 35.9 °C, the freeze should have a duration of more than 10 h with the temperature of the "plateau" constant to within 0.001 °C over that time.

If more than one thermometer is to be calibrated during a freeze, the second and later thermometers should be warmed to about 35 °C before inserting them into the re-entrant well of the cell.

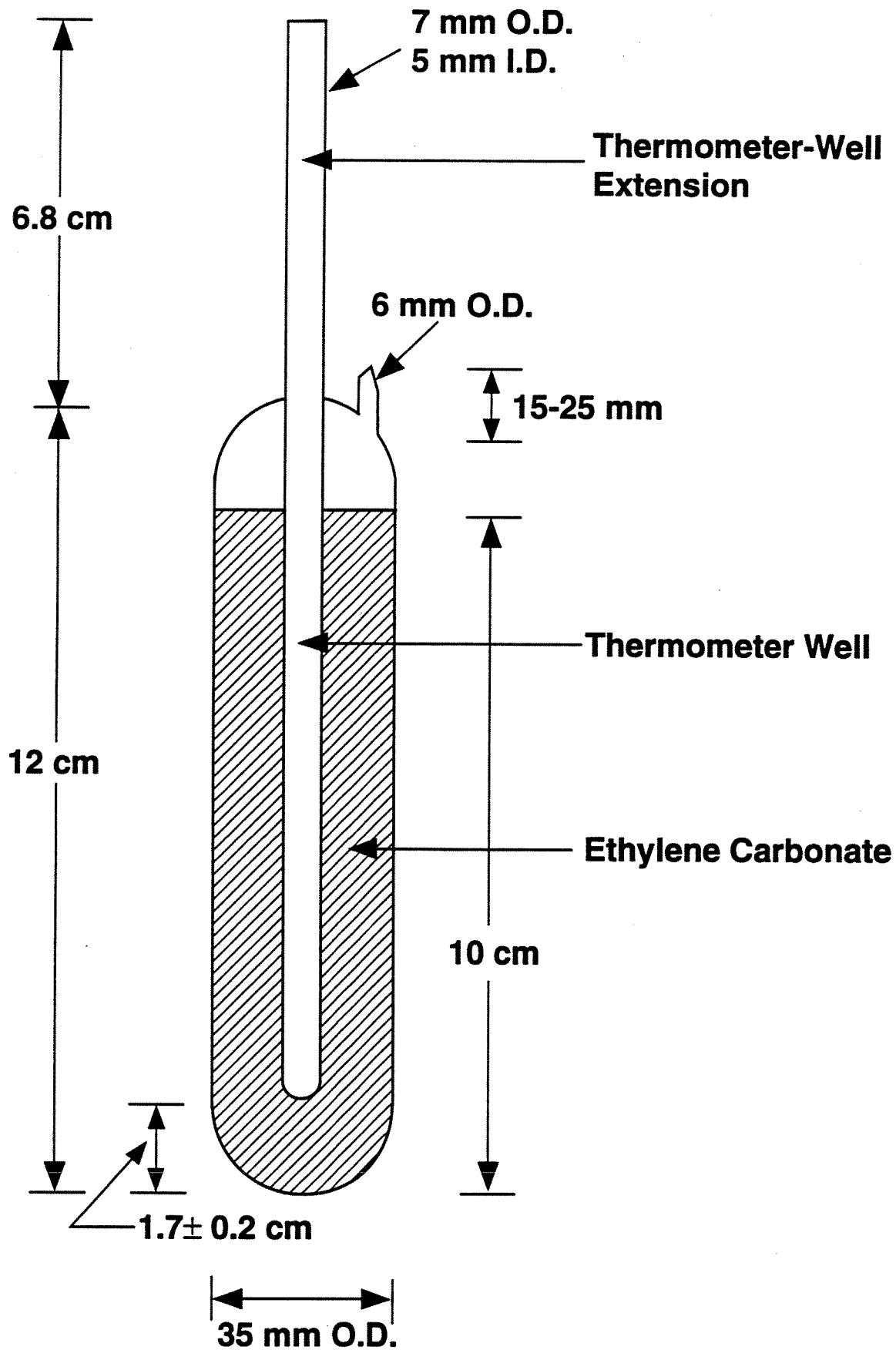

Figure 1. Cross-sectional drawing of the ethylene carbonate triple-point cell.