

# National Bureau of Standards

## Certificate

### Standard Reference Material 1971

#### Indium

#### Freezing-Point Standard

$156.635 \pm 0.002$  °C

### on The International Practical Temperature Scale of 1968

This Standard Reference Material (SRM) is intended to be used to calibrate thermometers at 156.635 °C. SRM 1971 consists of 100 grams of 99.9999% pure indium in an all Teflon\* and epoxy-sealed cell. The freezing-point temperature of SRM 1971 was verified using a set of four stable thermistors that were calibrated against a Standard Platinum Resistance Thermometer (SPRT). The SPRT, which was recently calibrated on the International Practical Temperature Scale of 1968 (ITS-68) in the NBS Platinum Resistance Thermometer Calibration Laboratory, was one of those used in the NBS investigation of the melting/freezing behavior of indium and the determination of its freezing-point temperature. The stated uncertainty of  $\pm 2$  mK is the estimated total uncertainty in the freezing-point temperature of indium as realized in SRM 1971.

SRM 1971 can be used to calibrate thermometers that have diameters less than 4.4 mm and that require immersion of no more than 7.0 cm in the uniform environment of the indium at its liquid-solid transition temperature. The transition-point temperature in SRM 1971 is best realized by the freezing technique.

#### Description of SRM 1971

SRM 1971 was designed by B.W. Mangum of the NBS Temperature and Pressure Division. The cell components were made by the NBS Fabrication Technology Division. The all-Teflon cell consists of a body, a well and a cap stem, as shown in Figure 1. Filling, assembling, and sealing of the cells were performed in a dry argon atmosphere by George A. Evans, Jr. of the NBS Temperature and Pressure Division. The cells were sealed with an organic epoxy.

The high-purity indium used in SRM 1971 was obtained from the Indium Corporation of America, Utica, New York.

The technical measurements at NBS leading to certification were performed by B.W. Mangum of the Temperature and Pressure Division.

The technical and support aspects involved in the preparation, certification, and issuance of this Standard Reference Material were coordinated through the Office of Standard Reference Materials by R. W. Seward.

**CAUTION:** Because the cells are constructed of Teflon and are sealed with an organic epoxy, SRM 1971 should not be heated above 165 °C. Temperatures at 170 °C and above could produce irreversible damage to the cell.

February 26, 1987  
Gaithersburg, MD 20899

Stanley D. Rasberry, Chief  
Office of Standard Reference Materials

(Over)

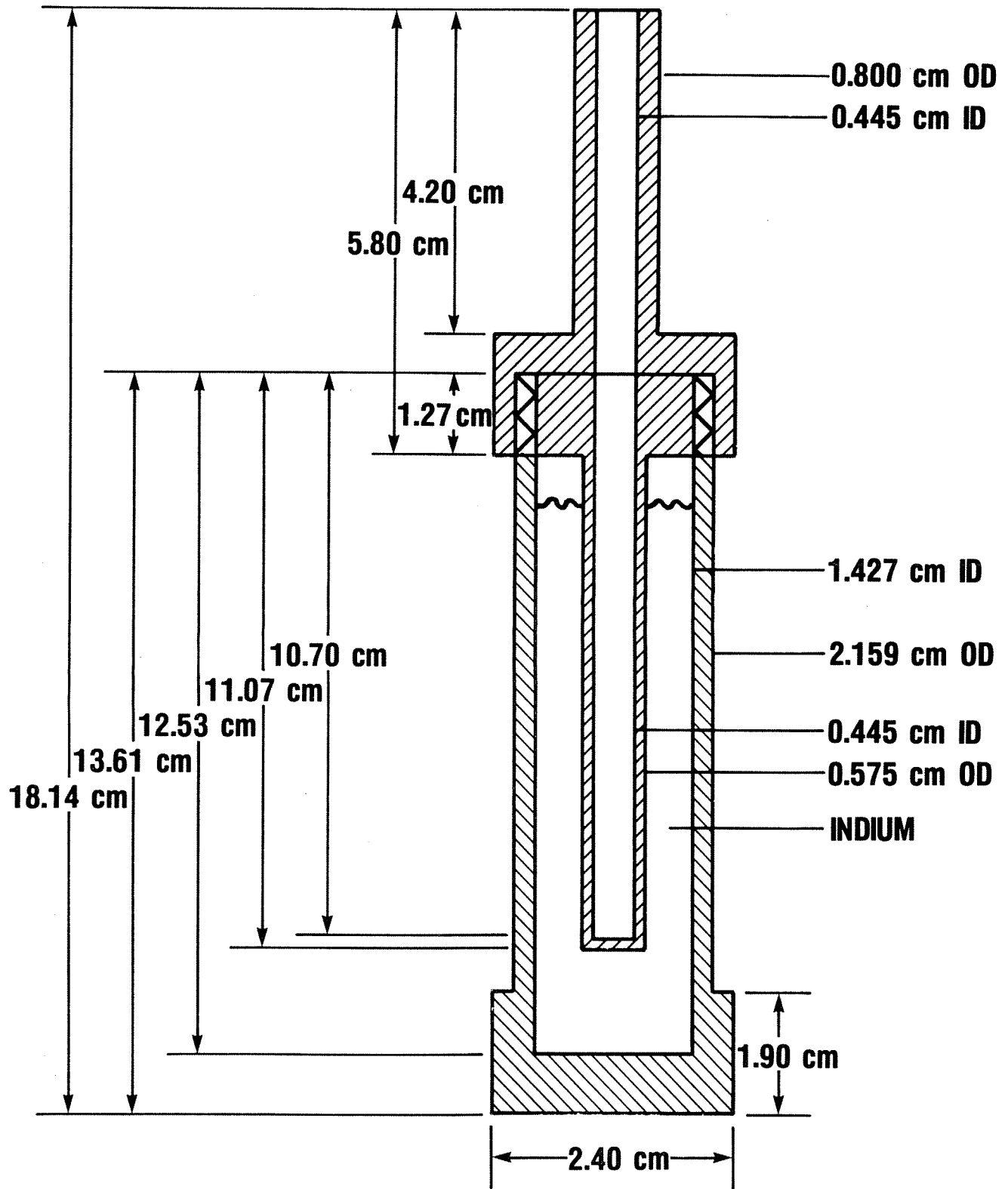

(FIG. 1)

Figure 1. Cross-sectional drawing of SRM 1971, Indium Freezing-Point Standard.

## Instructions for Use of SRM 1971

SRM 1971 should be used as a calibrant in a temperature-regulated environment. To calibrate a thermometer with SRM 1971, the user should employ a high-temperature silicone fluid, such as Dow Corning 710 fluid\*, in the well of the cell for thermal contact. Such a fluid may be used as the environment of the cell also; SRM 1971 may be totally immersed in such a fluid. Five to six hours of heating at 158 °C in a temperature-controlled environment are required for total melting of the indium if the cell is initially at room temperature. The indium should be melted during the night before the day it is to be used, or it may be stored in the molten state between 158 and 160 °C for instant use. To use the SRM for calibration, the indium must be in the process of freezing from the molten state. This can be accomplished by transferring SRM 1971 containing molten indium from a "melting" environment to a "freezing" environment, i.e., from an environment of approximately 158 °C to one of approximately 155 to 156 °C, or by rapidly decreasing the temperature of the environment.

For best results, a mantle of solid indium should be prepared around the thermometer well and along the wall of the cell. The outer mantle will form if the cell is held in ambient air for about 10 seconds. The cell should then be placed in the "freezing" environment, and a mantle around the thermometer well should be prepared. This can be done by inserting a 1/8 inch diameter copper rod, at ambient temperature, into the thermometer well filled with a high-temperature silicone fluid. The copper rod should be removed from the well after 3 to 5 seconds. Within 15 to 20 minutes after the mantles have formed, the SRM is ready for use in calibration.

Thermometers to be calibrated should be preheated before insertion into the SRM well. This will extend the duration of the freeze and also produce rapid attainment of equilibrium between the thermometer and the indium. With preheated thermometers, equilibrium should be attained within 5 to 15 minutes after insertion. Equilibrium can be ascertained by monitoring the thermometer and observing when its readings are steady.

A thermometer may be calibrated, once equilibrium is attained, by observing the reading of the thermometer that corresponds to the freezing-point temperature of SRM 1971, i.e.,  $156.635 \pm 0.002$  °C. That reading is the temperature of the thermometer *only* if the thermometer is adequately immersed. Adequate immersion may be checked by obtaining readings for the thermometer with its tip approximately 1 cm from the bottom of the well and with its tip at the bottom of the well. If the two values are the same within the uncertainty of the measurements, thermometer immersion is adequate and any uncertainty from this source is negligible. For best calibration results, the environment for the freeze should be regulated within 0.1 to 0.3 °C about a control point between 155 and 156 °C.

A typical freezing curve for SRM 1971 is shown at low resolution in Figure 2, and at higher resolution in Figure 3. This freeze was for a cell in an environment at 155 °C and controlled to better than  $\pm 0.1$  °C. The duration of a freeze depends on the temperature of the environment to which the cell is exposed. To maintain the cell temperature at the freezing point for a long period of time, the temperature of the environment to which the cell is exposed must be close to the indium freezing-point temperature. In Figures 2 and 3, a difference of 1.6 K existed between the indium freezing-point temperature and that of the cell environment. The resulting freeze lasted 180 minutes. If the temperature of the environment had been adjusted such that the difference between it and the indium freezing point was reduced to 0.8 K, the freeze would have lasted approximately 360 minutes. Conversely, if the difference had been increased to 3.2 K, the freeze would have lasted for approximately 90 minutes.

### SUPPLEMENTAL INFORMATION

The indium melting-point temperature may be used also for calibration, and SRM 1971 may be so used. Generally speaking, freezing-point determinations are more accurate and more precise than melting-point determinations; if the material is pure, however, the freezing-point and melting-point temperatures are the same. A typical melting curve of SRM 1971 at fairly low resolution is shown in Figure 4, and at higher resolution in Figure 5. This curve is for the same SRM 1971 cell as that of Figures 2 and 3. The melt of Figures 4 and 5 just preceded the freeze of Figures 2 and 3. Although the melting technique may be used in calibrations involving SRM 1971, the freezing technique is preferred and is the recommended procedure.

\*Use of trade name does not imply endorsement of this product by NBS.

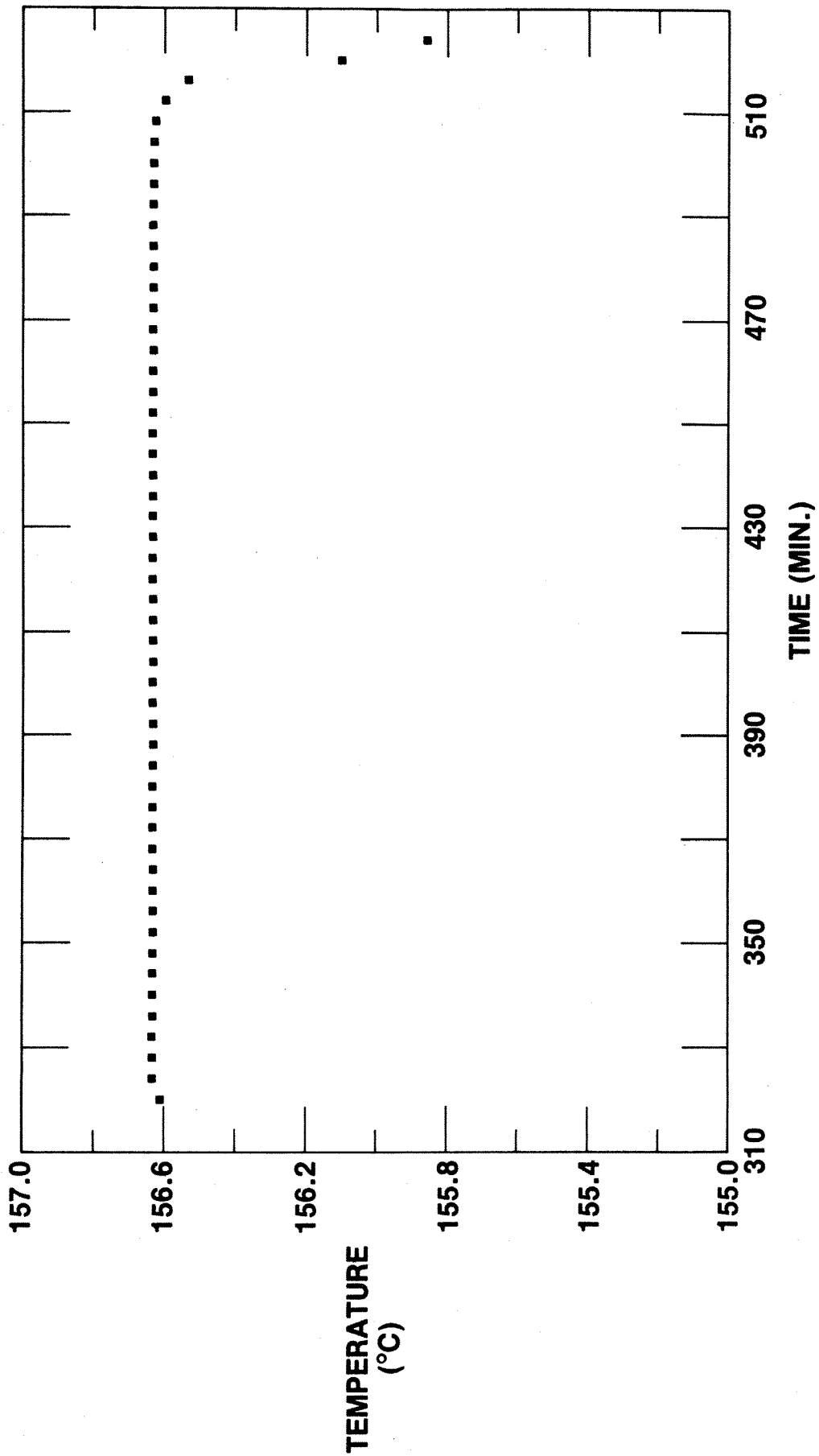

Figure 2. Typical freezing curve of SRM 1971 at low resolution.

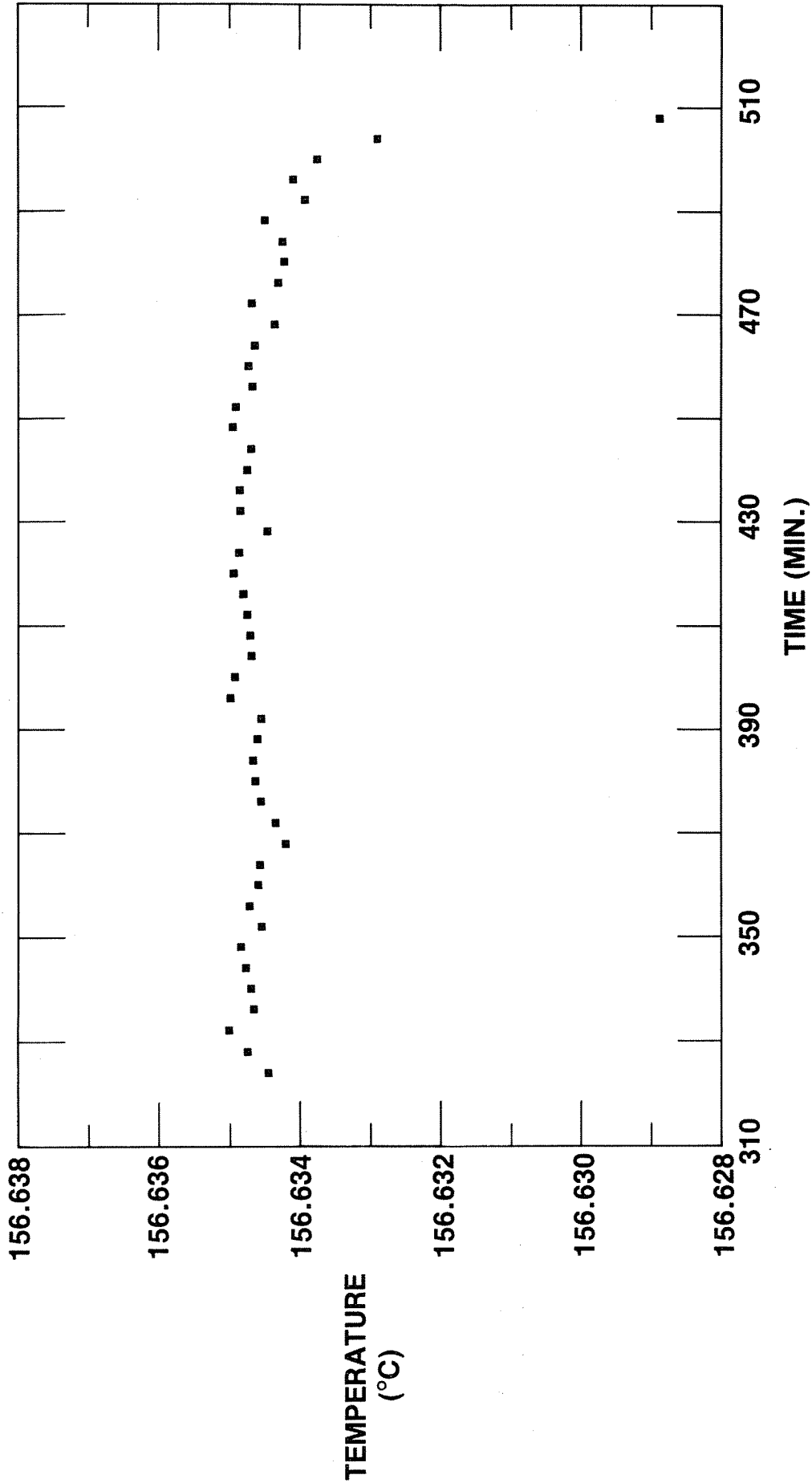

Figure 3. Same freezing curve of SRM 1971 as shown in Figure 2 but at higher resolution.

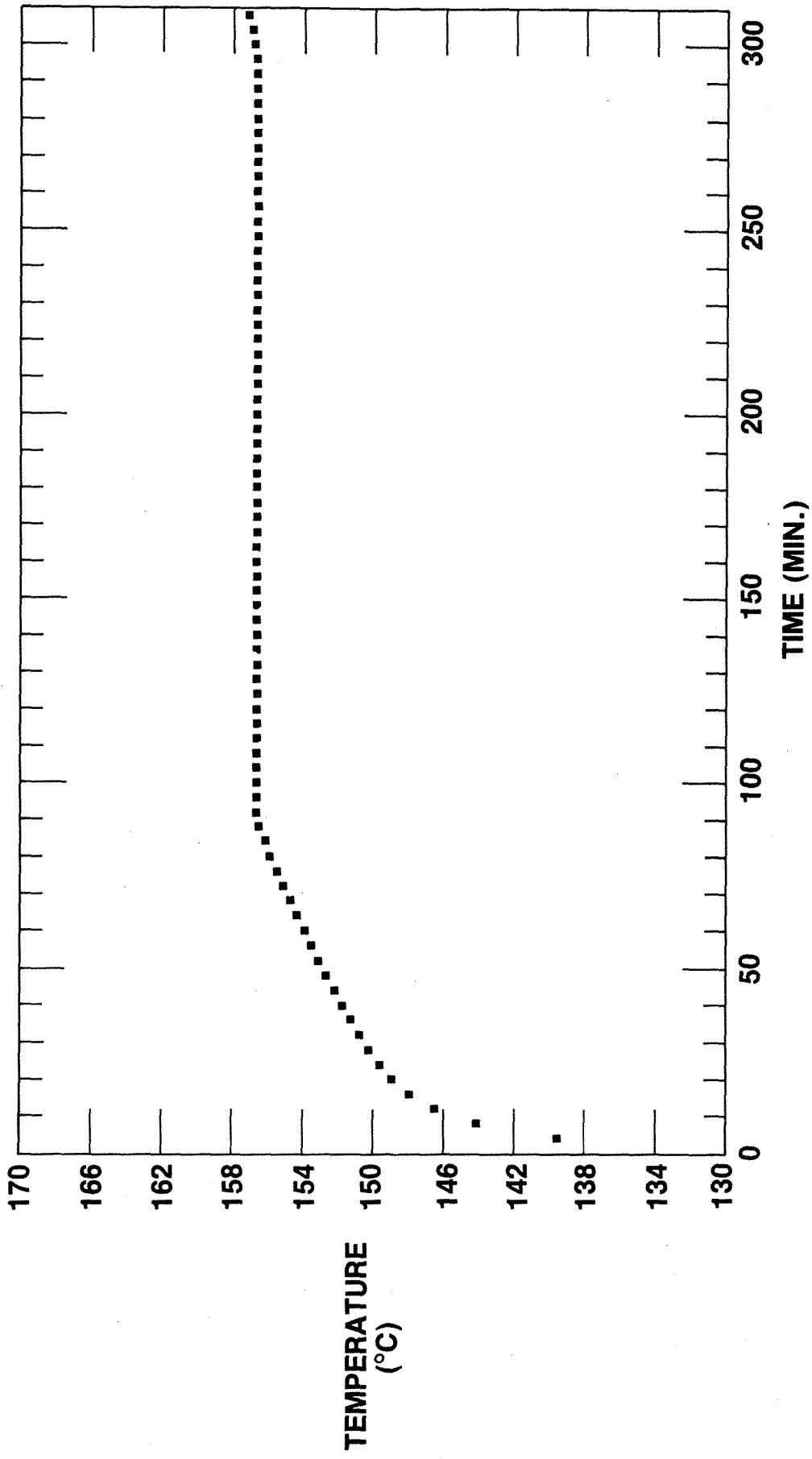

Figure 4. Typical melting curve of SRM 1971 at low resolution. This is for the same SRM 1971 cell as that of Figures 2 and 3.

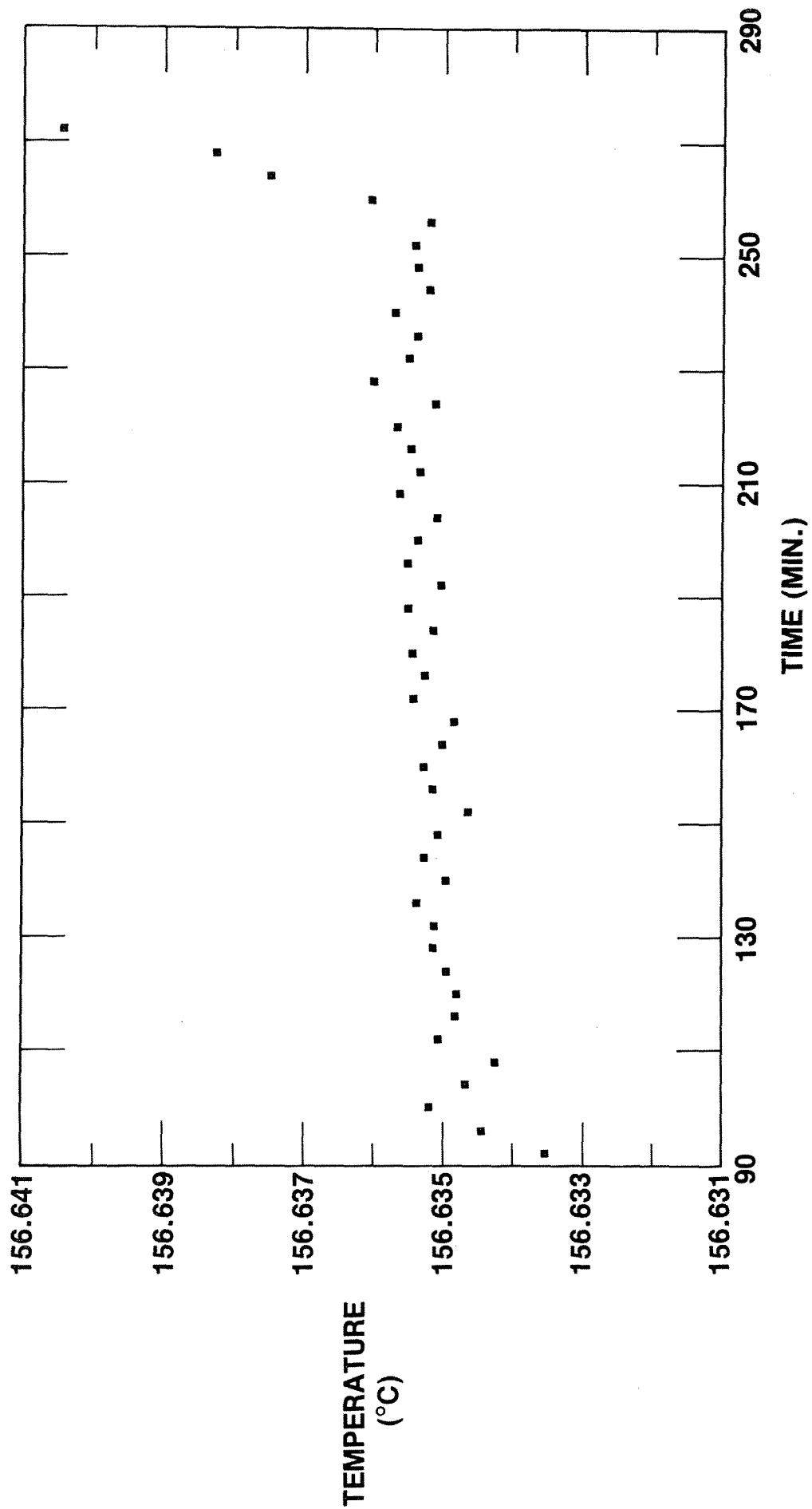

Figure 5. Melting curve of the same SRM 1971 cell as that of Figure 4 but at higher resolution.