

Dynamic calibration of instrumented Charpy strikers

ARTICLE INFO

Keywords:

Instrumented Charpy testing
Dynamic force
Dynamic force calibration

ABSTRACT

Charpy V-notch testing of metallic materials involves the application of kilonewton-range force pulses on millisecond time scales, generated by impacting the notched test specimen with a striker mounted on a swinging hammer. In the instrumented version of the test, strain gauges are affixed to the striker, and the voltage output from a strain gauge bridge amplifier is recorded in real time during the impact event. Calibration of the striker allows the voltage output to be converted to an applied force. The striker is typically calibrated statically, by dismounting it from the hammer and loading it with a universal testing machine. The highly dynamic impact conditions of a test can lead to errors in the force measurement based on such static calibration, and furthermore the dynamic response of the instrumented striker may be dependent on the hammer and the mounting of the striker to the hammer. Therefore we seek to perform a true dynamic calibration of the instrumented Charpy striker, and to perform this calibration on the striker as mounted in the Charpy machine.

We have developed a dynamic calibration method for instrumented Charpy strikers based on a short (relative to natural frequencies of the striker) force pulse, which approximates a delta function in time. By impacting the striker against small and very brittle ceramic specimens, we were able to generate force pulses as short as approximately 10 microseconds. Such short pulses have a nearly uniform force spectral amplitude up to a high frequency, allowing determination of the striker's frequency response function and impulse response function shapes. Furthermore, the calibration is carried out in conditions closely simulating those that occur in the use of the calibrated striker during Charpy tests.

We present the results of such dynamic calibrations for instrumented Charpy strikers on two different Charpy machines, the strikers for the different machines having different geometries.

1. Introduction

The Charpy test [1,2] is a widely popular material test that has been used since the early 1900s to characterize the capacity of a material to absorb energy before fracturing upon impact. This energy absorbing capacity, denominated as “impact toughness,” is used to evaluate the suitability of materials for applications ranging from ship hulls and railroad tracks to nuclear reactor pressure vessels. As illustrated in Fig. 1, in a standard Charpy test, a pendulum (hammer) is released from a raised position and allowed to impact a notched specimen that is resting against anvils. The total energy loss in fracturing the specimen is usually determined from the difference in the height of the hammer from its initial position to its maximum rise after the specimen fracture, accounting for losses due to windage and friction. The impacting portion of the hammer is called the striker, and in an instrumented Charpy test [3, 4] strain sensors are attached to the striker to generate an output signal (usually a voltage) indicative of the instantaneous force $F(t)$ acting on the striker. An example of an instrumented striker is shown in Fig. 2. The $F(t)$ trace generated by an instrumented Charpy test provides additional information about the material, and can also provide an alternative path to evaluating the absorbed energy (impact toughness) [5].

The force traces, $F(t)$, in an instrumented test are typically pulses with durations ranging from ≈ 0.1 ms to ≈ 5 ms. An example for a partially brittle/partially ductile test is shown in Fig. 3. Instrumented

Charpy strikers are commonly calibrated statically, using a calibrated universal testing machine. Given the timescales of the force variations in a Charpy test, it is natural to expect some dynamic effects in the instrumented striker response, and accounting for such effects may be necessary in order to obtain force measurements of acceptable accuracy. Comparisons of force measurements among statically calibrated instrumented Charpy strikers in Charpy machines at different laboratories revealed differences in measured maximum forces exceeding 10 % [6].

The perceived inadequacy of the static calibration and the observed variability of results using statically calibrated strikers have led to methods being developed to account for the difference between the dynamic and static responses of instrumented strikers. One developed approach is to use the fact that the integration of force over displacement gives energy to derive a force sensitivity from the absorbed energy obtained from the hammer heights. This approach has been used to reduce disagreement among instrumented Charpy machines [6] but does not account for the time and frequency dependence of the dynamic effects. Dynamic calibration using a known force pulse input to obtain the dynamic sensitivity function has been pursued [7], and the work we report in this paper is similar in approach; however, the methods we use are different and provide a higher calibration bandwidth, and uncertainty was not estimated in the prior work [7].

In the following two sections of this paper, we describe respectively

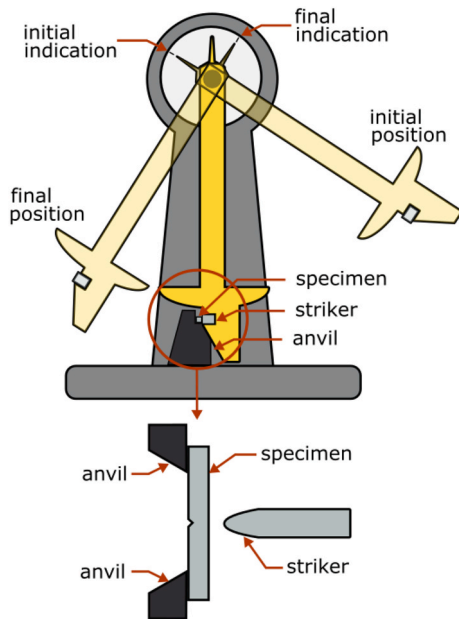

Fig. 1. Schematic drawing of a Charpy machine and a Charpy specimen being tested.

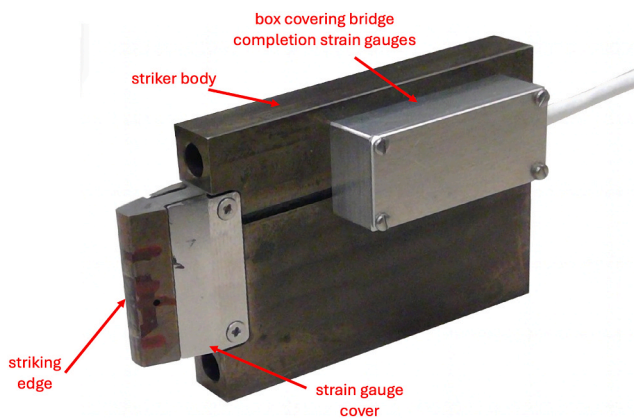

Fig. 2. Example of an instrumented Charpy striker.

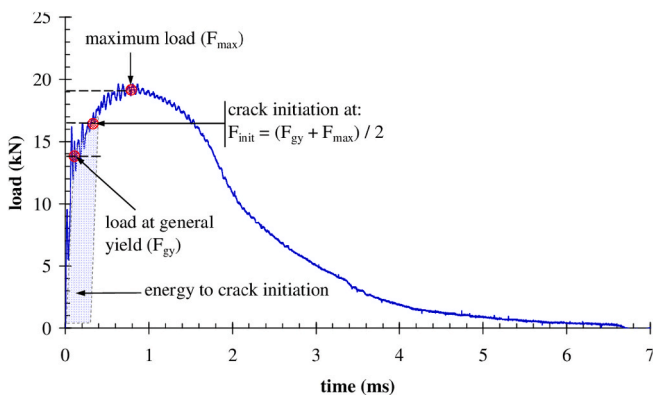

Fig. 3. Illustrative force-time trace from an instrumented Charpy test on a metallic specimen exhibiting ductile-to-brittle transition behaviour. Some of the important quantities extracted from such test records are indicated. Figure adapted from Ref. [3].

the desired features of a calibration method for instrumented Charpy strikers, and possible types of calibration force inputs. In section 4, we describe the calibration method that we have developed. In section 5 we show example instrumented striker calibrations obtained using this method, and in section 6 we conclude with a short discussion.

2. Calibration requirements

Key features of an instrumented Charpy test force/time trace are shown in Fig. 3, which provide valuable information about the material under test. Accurate measurement of the force/time trace requires calibration of the striker dynamic sensitivity with a sufficient bandwidth (i.e., up to a sufficiently high frequency), with significant force spectral content exceeding 10 kHz in many Charpy tests. The dynamic sensitivity of an instrumented striker is, in general, not just a property of the isolated striker but rather a property of the striker in combination with the pendulum in which it is mounted and with the pendulum installed in the Charpy machine, together with the 'readout' system for the striker output voltage, e.g., strain gauge amplifier, digitizer, cables, and any additional signal conditioning or processing performed in obtaining the voltage. We take the approach of calibrating all these together as a single 'instrumented striker', with instrument settings the same as they would be in a Charpy test to which the calibration applies. For a calibration method to be useful, simplicity and practicality of implementation should be maximized, and the effort required to carry out the calibration should be minimized.

In order to enable traceable measurements, it is necessary to determine the uncertainty of the calibration. This uncertainty includes contributions due to imperfect knowledge of the input force used in the calibration, as well as imperfect measurement of the output voltage from the striker. The uncertainty components may be evaluated as Type A and/or Type B contributions; they may not necessarily be attributable to particular sources. For example, an evaluation of Type A uncertainty from multiple repeated impacts may capture effects of uncertainty contributors related to the input force as well as contributors related to the output voltage. When the calibration is applied in an instrumented Charpy test, additional uncertainty contributions need to be considered. These uncertainties include possible differences in the striker dynamic sensitivity determined by the calibration and the dynamic sensitivity applicable to the instrumented Charpy test; for example, these could be caused by differences in the spatial distribution of force on the striker.

We assume that the instrumented Charpy striker is a linear and time-invariant system. The dynamic response of such a system can be represented in the time domain as an impulse response function, namely, the dynamic response of the system to a perfect (zero time duration) impulse input. The calibration task is therefore to determine this impulse response function as accurately as possible, and with quantified uncertainty.

3. Possible calibration forces

The basic requirement for a calibration force input is to provide a known force/time waveform that excites the relevant dynamic response of the striker. In frequency domain terms, the spectral amplitude of the excitation waveform should be large enough to generate a voltage output significantly greater than the noise at all relevant frequencies. It is not necessary to know the absolute amplitude of the force/time waveform, as a relative dynamic sensitivity obtained without knowing the absolute amplitude can be scaled to a known "single-point" sensitivity, in particular to the static sensitivity. We briefly describe here a few different classes of calibration input force waveforms that may be used.

Known pulse: In this case, a force pulse of a known shape is applied to the instrumented striker. "Known shape" means here that there is a low uncertainty in the relative force amplitude at all points in the force pulse. The pulse should be of sufficiently short duration to excite the

relevant dynamics of the striker response.

Known sines: In this case, a set of sine waves is used to perform a frequency domain calibration by obtaining the complex voltage response from the striker as a function of frequency. The sine waves may be at discrete frequencies that are spaced sufficiently closely, or span a continuous range of frequencies by using a swept-sinusoidal force waveform. In either case, it is necessary that the relative amplitudes of the applied sinusoidal forces at each frequency be known.

Fast pulse: In this case, a force pulse of much shorter duration than the relevant dynamic features of the striker response is used. Such a force can be approximated as a delta function in time, meaning that the observed dynamic response of the striker is directly the desired impulse response function (up to a possible amplitude scaling), which captures the full dynamic response of the striker. With such a short force pulse, details of the pulse shape within the rapid pulse do not need to be known.

Fast step: If a fast step is applied rather than a fast pulse, the step response of the striker is obtained, which again captures the full dynamic response. The impulse response is given by the derivative of the step response. As with the fast pulse, the requirement is that the time duration of the force step is short compared to the dynamic response of the striker.

4. Ceramic test specimen calibration method

We describe here the method we have implemented to obtain the dynamic response of instrumented Charpy strikers. This follows the "fast pulse" approach described in section 3. By performing a regular instrumented Charpy test on a highly brittle material, we generate a force pulse on the instrumented striker that is much shorter than the force pulse widths for standard (metallic) Charpy test specimens. Using the commercial glass ceramic material Macor® [8,9], we are able to generate short pulses with a material that is easily machinable into Charpy V-notch specimens, readily available, and relatively inexpensive. An advantage of this approach is that the calibration procedure is basically the same as a standard Charpy test. In principle, the calibration can be performed close in time (for example immediately before and/or after) Charpy tests on specimens of interest.

We constructed the electrical circuit illustrated in Fig. 4 to investigate this method. By coating a ceramic specimen with conductive paint, we form an electrical circuit that generates an output voltage indicating the state of the ceramic specimen in terms of contact with the instrumented striker and whether or not the specimen is broken, as illustrated in Fig. 5. Fig. 6 shows an example calibration test record using such a conductive-paint-coated ceramic specimen. We observe that the electrical continuity time duration indicated by the contact circuit voltage is greater than the observed width of the voltage pulse output from the instrumented striker due to the impact force. We interpret this to indicate that electrical continuity is present in some cases even without any

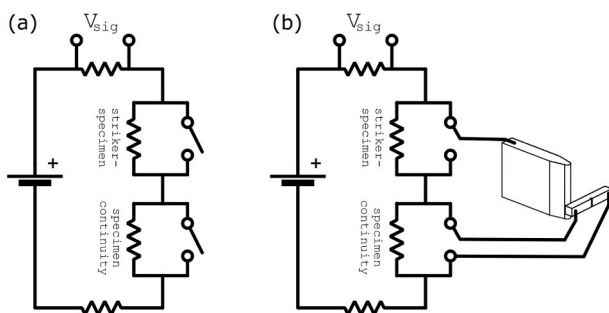

Fig. 4. Diagram of electrical circuit assembled to indicate the duration of the force pulse based on interruption of the current path when the specimen fractures. The insulating ceramic specimen was made conductive by a thin layer of conductive paint applied on it.

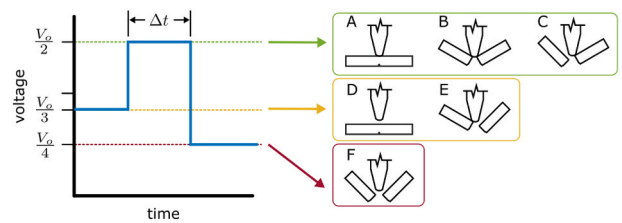

Fig. 5. Illustration of the voltage steps deriving from the different conditions of the conductive calibration specimen and striker that occur during the calibration impact.

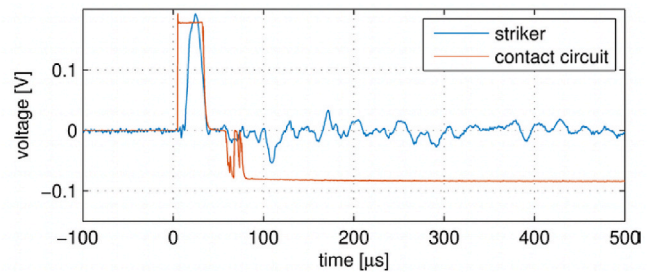

Fig. 6. Voltage outputs from the continuity-indicating contact circuit and the instrumented striker during a calibration test with a conductive-paint-coated ceramic specimen. The voltage scale for the output of the contact circuit is not shown.

observable force acting between the specimen and the striker. Some ways in which this may occur are illustrated as conditions B and C in Fig. 5; other possibilities include details of the support condition of the ceramic specimen on the Charpy machine anvils. We assume that the voltage output from the striker does not go to zero at (propagation-adjusted) times while the force acting on the striker is non-zero, and that the force that acts on the striker due to the impact event is a single pulse (albeit of possibly complicated shape) that remains greater than zero (compressive) for the duration of the impact. Thus, we conclude that an upper bound to the duration of the applied force pulse is given by the lesser of the duration indicated by electrical continuity and the duration of the first peak of the output voltage. Further investigation of the validity of these assumptions may be warranted. Based on the observation that the voltage pulse was usually shorter than the electrical-continuity duration, electrical continuity measurements were not performed in the calibrations reported below in Section 5.

By testing ceramic specimens with square cross sections of 12.7 mm side length and of 6.35 mm side length, we find unsurprisingly that the smaller specimens provide pulses of shorter duration, at the cost of reduced amplitude. The reduction in time duration is of greater importance for our calibration, as the reduction in signal-to-noise ratio due to reduced amplitude can be compensated for by averaging a larger number of calibration specimen tests.

5. Example instrumented striker calibrations

The method described in Section 4 was used to calibrate four instrumented strikers, three of these being different strikers for a Charpy machine with a "Z-type" hammer and one for a Charpy machine with a "U-type" hammer. The strikers were each paired with the same strain gauge bridge amplifier, but with different settings for the different strikers and Charpy machines. The bridge amplifier was allowed to warm up for at least 30 minutes before the calibration tests.

Macor glass ceramic Charpy V-notch specimens with 6.35 mm × 6.35 mm square cross-section were used for the calibrations. No metallic paint was applied to these specimens. A total of 17–26 calibration Charpy tests were performed on each striker, divided between two

testing periods separated in time by approximately three months, as reported in Table 1. The output voltage was digitized at a rate of 2 MHz. From each collected voltage trace, a small DC offset given by the mean value of the initial portion of the trace before the impact event was subtracted. Collected traces were discarded if:

- (a) abnormally high noise levels were detected;
- (b) the peak voltage occurred too close to the start of the collection window;
- (c) the width of the first voltage peak, measured at the 10-percent-of-maximum points, was more than 10 % wider than the minimum width of the first voltage peak observed across all traces collected for that striker.

Criteria (a) and (b) were applied in order to prevent corrupt data from being used in the calibration. Criterion (c) was applied in order to use only traces resulting from the shortest force pulse inputs, with the observed voltage pulses providing an upper bound to the force pulse duration. We observed a tendency for the calibration voltage traces for a given striker to be split into groups, with a subset of the traces being highly similar and having minimum duration of the first pulse. We hypothesize that this may be due to differences among the macor specimens (material properties or machined finish/geometry), or due to differences in the support of the macor specimens on the Charpy machine anvils.

Application of these selection criteria resulted in retention of 29 %–59 % of the collected traces for each striker, as reported in Table 1. The retained traces were then aligned in time according to the location of the first 20-percent-of-maximum point and scaled to the peak voltage (i.e., peak value set to 1). The mean at each time point of the retained traces for each striker was then calculated to obtain the calibration output (impulse response function), along with the standard deviation and standard error of the mean at each time point. The total duration of the obtained impulse response functions was approximately 1 ms, except for striker MPM-JS2, for which only 65 microseconds were obtained.

The resulting impulse response functions (first 65 μ s–100 μ s) are shown in Fig. 7 for the four strikers. The strikers represented in Fig. 7(a), (b), and 7(c) (denoted by MPM-JS2, MPM-JS3, and MPM-JS4) are all for the same Charpy machine and have a roughly similar design, although they differ in some important details, as reflected by the differences observed in their dynamic responses. The striker denoted by TO2-JSopt and represented by Fig. 7(d) has a different shape and is used with a different Charpy machine.

Table 1
Calibration traces collected and retained for four instrumented strikers, using glass ceramic calibration specimens with 6.35 mm \times 6.35 mm cross-section.

Striker	Date	Number of traces collected	Number of traces retained
MPM-JS2	23-Sep-2022	7	1
	19-Dec-2022	10	4
MPM-JS3	28-Sep-2022	8	5
	19-Dec-2022	10	4
MPM-JS4	22-Sep-2022	7	4
	20-Dec-2022	10	6
TO2-JSopt	22-Sep-2022	8	2
	19-Dec-2022	9	1
	20-Dec-2022	9	2
	20-Dec-2022	9	2

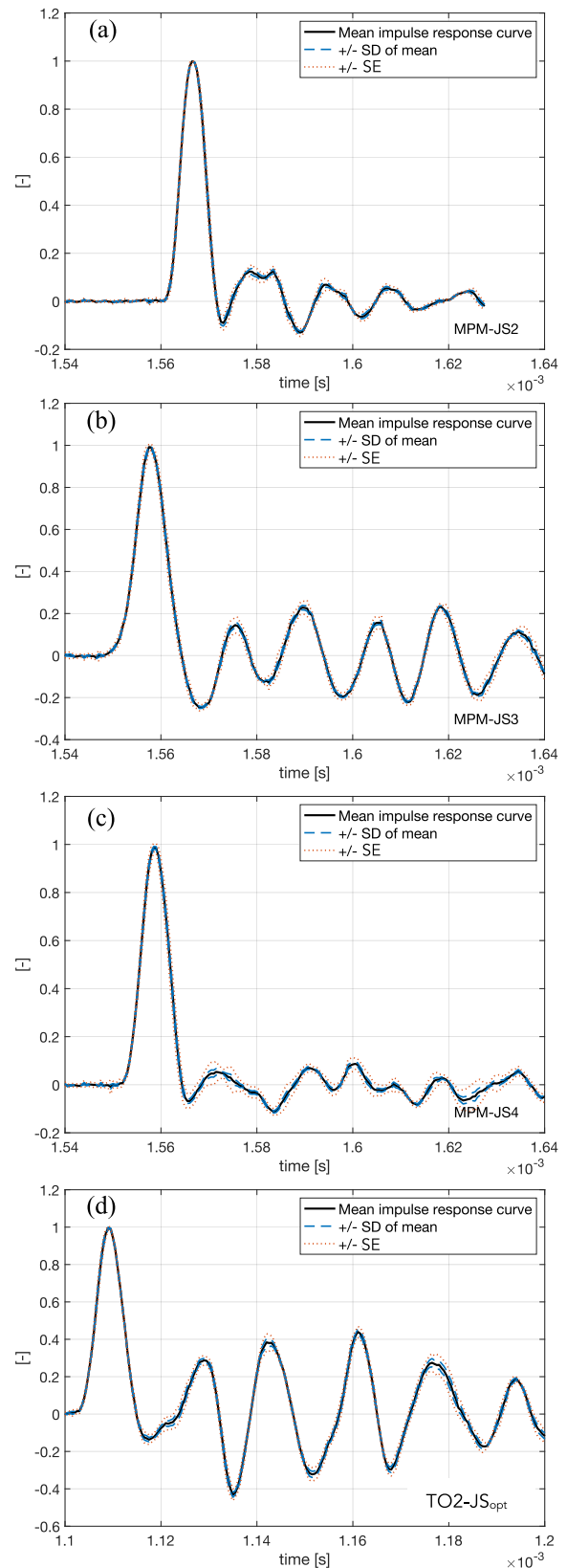

Fig. 7. Instrumented striker calibration curves for four instrumented strikers, obtained using the method described in Section 4. The plotted curves are the mean impulse response from several calibration impact events, along with the standard deviation and the standard error of the mean. The number of impact events averaged in each case was: (a) 5, (b) 9, (c) 10, and (d) 5.

The standard error of the mean accounts for random noise in the obtained calibration traces from one impact to another, for example due to random components of electronic noise, which are not part of the true striker response. The standard deviation includes possible variations in the actual dynamic response from one calibration event to another, for example, due to drift in some component of the composite striker being calibrated, or due to the dependence of the response on the precise contact location on the striker and small variations in this contact location. The possibility of such variability in the 'true' dynamic response dictates which of these uncertainty measures is appropriate for estimating the type A contribution to the calibration uncertainty.

In addition to these type A contributions, there is a type B calibration uncertainty contribution due to the fact that the duration of the calibration force pulse is unknown, with only a (finite) upper bound for this duration being known. A time-domain description of this uncertainty contribution is as follows: based on taking the duration of the first output voltage pulse as the upper bound to the duration of the calibration force pulse, we can only say that the duration of the true impulse response first pulse may range from 0 (the case where the duration of the force pulse is the same as the duration of the observed output voltage pulse) to the observed output voltage pulse duration (the case where the duration of the force pulse is 0). This "calibration force pulse duration uncertainty" contribution must be included in the uncertainty propagation when using the calibrated impulse response function.

6. Concluding discussion

To improve the calibrations reported in Section 5, additional investigation of the type A uncertainty components should be performed. In particular, repeated calibrations of the same striker over time should be used to check for drift in the striker dynamic response. Likewise, investigation should be undertaken into whether there is variation of the impact location on the striker from one calibration impact to another that causes variation in the striker dynamic response. We note that strikers can be designed to minimize sensitivity to impact location [10].

The determined striker impulse response functions will ultimately be used to estimate the force trace in instrumented Charpy tests by deconvolving the impulse response functions from the obtained Charpy test voltage traces. The calibration uncertainty components must be propagated in this process and will be combined with other uncertainty components arising in the Charpy test of interest to obtain the final

uncertainty estimate for the force. It may be necessary to include information on correlations between different time-points in the calibrated impulse response in addition to the variances at each point, in order to obtain a correct uncertainty estimate for the force in the Charpy test.

References

- [1] International Organization for Standardization, ISO 148-2:2016, Metallic Materials—Charpy V-Notch Pendulum Impact Test—Part 1: Test Method.
- [2] ASTM International. ASTM E23-16b, Standard test methods for notched bar impact testing of metallic materials DOI: <https://doi.org/10.1520/E0023-16B>.
- [3] International Organization for Standardization, ISO 14556:2023, Metallic Materials - Charpy V-Notch Pendulum Impact Test - Instrumented Test Method.
- [4] ASTM International, ASTM E2298-15, Standard test method for instrumented impact testing of metallic materials DOI: <https://doi.org/10.1520/E2298-15>.
- [5] ASTM International, ASTM E2298-15, Standard test method for instrumented impact testing of metallic materials DOI: <https://doi.org/10.1520/E2298-15>.
- [6] E. Lucon, On the effectiveness of the dynamic force adjustment for reducing the scatter of instrumented Charpy results, *J. ASTM International* 6 (1) (2008) 1–9.
- [7] H. Inoue, H. Ishida, K. Kishimoto, T. Shibuya, Measurement of impact load by using an inverse analysis technique (comparison of methods for estimating the transfer function and its application to the instrumented Charpy impact test), *JSME International Journal, Series I* 34 (1991) 453–457.
- [8] <https://www.corning.com/worldwide/en/products/advanced-optics/product-materials/specialty-glass-and-glass-ceramics/glass-ceramics/macor.html> [accessed 14 May 2024].
- [9] Certain commercial equipment, instruments, or materials are identified in this paper in order to specify the experimental procedure adequately. Such Identification Does Not Imply Recommendation or Endorsement by the National Institute of Standards and Technology (NIST), Nor Does it Imply that the Materials or Equipment Identified Are Necessarily the Best Available for the Purpose.
- [10] N. Vljajic, A. Chijioke, E. Lucon, Design considerations to improve Charpy instrumented strikers, *J. Res. NIST* 125 (2020) 125010, <https://doi.org/10.6028/jres.125.010>.

Akobuije Chijioke^{a,*}, Nicholas Vljajic^b, Enrico Lucon^c

^a National Institute of Standards and Technology, Gaithersburg, MD, 20899, USA

^b The Pennsylvania State University, University Park, PA, 16802, USA

^c National Institute of Standards and Technology, Boulder, CO, 80305, USA

* Corresponding author.

E-mail addresses: ako.chijioke@nist.gov (A. Chijioke), nav5000@psu.edu (N. Vljajic), enrico.lucon@nist.gov (E. Lucon).