





Vapor-cavity-QED system for quantum computation and communication

Sharoon Austin ^{1,2,*}, Dhruv Devulapalli,^{1,2} Khoi Hoang ^{1,3}, Feng Zhou,^{1,3}
Kartik Srinivasan ^{1,3} and Alexey V. Gorshkov ^{1,2}

¹*Joint Quantum Institute, NIST/University of Maryland, College Park, Maryland 20742, USA*

²*Joint Center for Quantum Information and Computer Science, NIST/University of Maryland, College Park, Maryland 20742, USA*

³*Microsystems and Nanotechnology Division, Physical Measurement Laboratory, National Institute of Standards and Technology, Gaithersburg, Maryland 20899, USA*



(Received 17 October 2025; accepted 20 March 2026; published 28 April 2026)

In this work, we propose performing key operations in quantum computation and communication using room-temperature atoms moving across a grid of high-quality-factor, small-mode-volume cavities. These cavities enable high-cooperativity interactions with single atoms to be achieved with a characteristic timescale much shorter than the atomic transit time, allowing multiple coherent operations to take place. We study scenarios where we can drive a Raman transition to generate photons with specific temporal shapes and to absorb, and hence detect, single photons. The strong atom-cavity interaction can also be used to implement the atom-photon controlled-phase gate, which can then be used to construct photon-photon gates, create photonic cluster states, and perform nondemolition detection of single photons. We provide numerics validating our methods and discuss the implications of our results for several applications.

DOI: [10.1103/physrevresearch.8.023082](https://doi.org/10.1103/physrevresearch.8.023082)

I. INTRODUCTION

The ability to create single photons, implement photon-photon gates, create photonic cluster states, and detect single photons is important for performing quantum computation [1,2], quantum communication [3], and quantum metrology [4]. Moreover, it is important to execute these operations in a scalable way to produce large-scale systems capable of implementing quantum error correction and solving large problems [5].

Single-photon sources have been realized using quantum dots [6] and atoms [7] in high-finesse cavities. Moreover, the use of auxiliary classical fields to control the shape [8,9] and polarization [10] of the emitted photons has also been demonstrated. However, spectral inhomogeneities in quantum dots [11] and the technical demands to cool and trap atoms [12,13] make scalability challenging. Similarly, state-of-the-art single-photon detectors based on superconducting nanowires require cryogenic operating temperatures [14].

In this paper, we propose an architecture, shown schematically in Fig. 1, that can realize key photon processing primitives—photon sources, photon detectors, and photon-photon gates—without the physical infrastructure associated with laser cooling and trapping or cryogenics, and with a level of homogeneity that exceeds that of most solid-state quantum optical systems (such as quantum dots). Our architecture uses room-temperature atoms moving across a grid of

high-quality-factor, small-volume cavities in a regime where strong atom-cavity interactions (large single-atom cooperativity) can be achieved. Previous work with cold atoms in cavity QED (quantum electrodynamics) systems has demonstrated all the key steps in implementing the prerequisite strong atom-light interactions [18–23]. In contrast, warm atoms present an additional challenge due to the finite time over which they are present within the cavity mode volume. Thus, to make use of this architecture for photonic quantum information processing, it is important that the atom's transit time through a cavity is much longer than the time it takes to generate a single photon, detect a single photon, or implement an atom-photon quantum gate. As a result, while cavity QED with warm atoms was pursued in groundbreaking experiments decades ago [24,25], the aforementioned challenge pointed toward cold-atom cavity QED as a more fruitful path for realizing coherent single-photon operations.

In this paper, we argue that developments in integrated photonics and microfabricated atomic devices suggest that cavity QED with warm vapors is worth revisiting, as recently noted in Ref. [26]. In particular, there has been continued development of integrated photonic microcavities with ultrasmall mode volumes and high quality factors [26–29], so that high-cooperativity atom-photon interactions are achievable. Moreover, recent work on microfabricated atomic beam collimators [30] has shown that they can be incorporated together with microfabricated atomic vapor sources [31], thereby limiting the transverse velocity of the atoms. Taking these developments together, the timescale for coherent atom-photon interactions can be more than 2 orders of magnitude shorter than the atomic transit time, so that an appreciable number of single-photon operations can occur while the atom is interacting with the cavity. From a technology perspective, in recent years, there have been several efforts to create hybrid platforms enabling near-field

*Contact author: sharoon@umd.edu

Published by the American Physical Society under the terms of the [Creative Commons Attribution 4.0 International](https://creativecommons.org/licenses/by/4.0/) license. Further distribution of this work must maintain attribution to the author(s) and the published article's title, journal citation, and DOI.

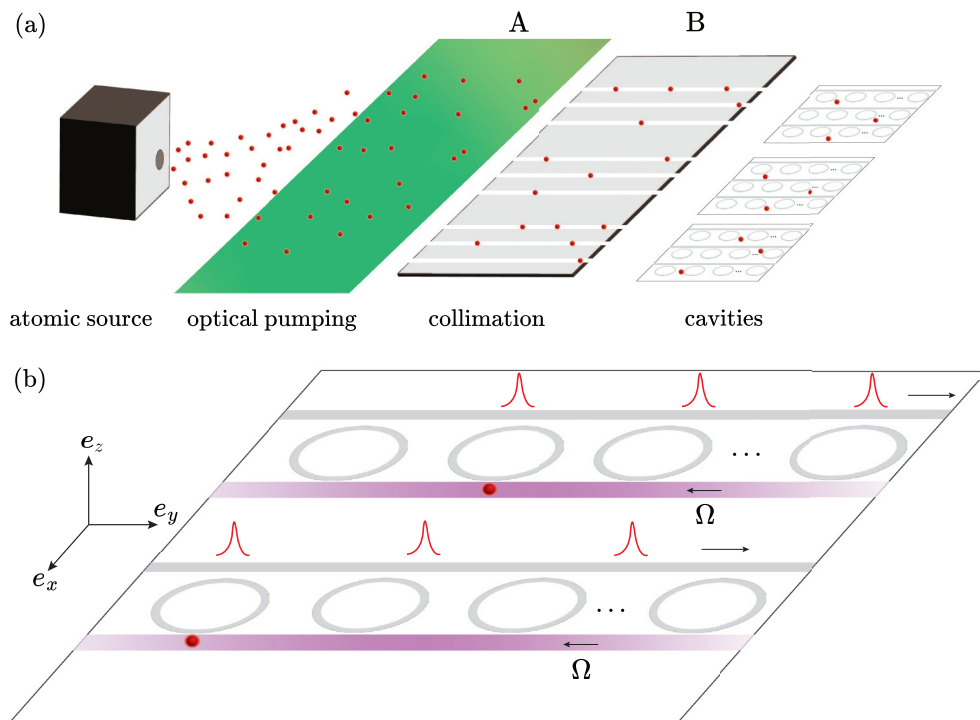

FIG. 1. A schematic of the envisioned vapor cavity QED architecture. (a) The atoms produced from a thermal source go through two stages before entering the microcavity chips. In stage A, the atoms are optically pumped using a laser (shown in green) so that they are initialized in the correct atomic state. In stage B, the atoms pass through a beam collimator to limit their transverse velocity. (b) A schematic of the cavity QED chip. The atoms, moving in a collimated beam parallel to the waveguides, couple to microcavities arranged in a grid. This figure shows the generation of single photons (red wave packets) with the help of free-space control pulses Ω (shown in purple). All other operations discussed in this work can be implemented similarly. Moreover, while microring whispering-gallery mode cavities [15,16] are depicted, our approach applies to other geometries, such as racetrack microcavities [17] and single-sided photonic-crystal cavities [18].

interactions between integrated photonics and atomic vapors in fully integrated systems [32,33], including recent experimental work demonstrating atom-cavity interactions at the level of a few atoms and a few intracavity photons [34]. Given the ability to create large arrays of devices through nanofabrication, and the ability to operate warm atoms without the auxiliary infrastructure associated with cooling and trapping, we anticipate our approach will be particularly well positioned to benefit from the use of multiplexing.

In the sections that follow, we outline well-known vapor-cavity-QED-based protocols and optimize them for the parameter regimes suitable for our system. In Sec. II, we describe in detail our setup based on vapor cavity QED, and in Sec. III, we summarize the considerations specific to working with warm atoms. In Sec. IV, we discuss schemes in two different parameter regimes to generate and detect single photons. In Sec. V, we study the physics of the atom-photon gate. In Sec. VI, we discuss applications of the basic primitives, including making cluster states [35,36] and performing quantum communication protocols [3]. Our work complements other recent studies of warm-atom cavity QED systems, such as Ref. [26], where the potential for observing vacuum Rabi splitting and single-atom transits through an ultrasmall volume photonic-crystal cavity was studied.

II. VAPOR-CAVITY-QED SYSTEM

The system we consider consists of a grid of chip-scale microcavities that are linked to a warm-atom source through

an atomic beam collimator, as depicted in Fig. 1, and it is expected that the entire system can be micro/nanofabricated and linked together in a compact and deployable package, for example, as has recently been demonstrated for atomic beam clocks [31].

The cavities have ultralow mode volumes and high quality factors that allow for strong atom-photon coupling, and the key parameters of the system include the single-photon Rabi frequency g , the rate κ_{ex} at which the microcavity couples to the waveguide, the intrinsic loss κ_i of the microcavity, and the decay rate γ of the atomic coherence. Here, τ is defined as the time during which the atom interacts with the cavity mode. Taking the racetrack microcavity as an example, τ is defined as the time it takes for the atom in a collimated beam to traverse the longest dimension, as shown in Fig. 2.

Microcavities come in a variety of geometries, including microdisks [15], microrings [16], microbottles [37], and photonic-crystal defect structures [26,29,38]. These microcavities couple to the waveguide and the atom through their evanescent modes. Moreover, the tight confinement of single-photon fields allows for ultrasmall mode volumes and hence large single-photon electric fields and strong atom-field couplings [39,40].

We consider two different polarizations of the modes of resonators, as shown in Fig. 3. For the perfectly chiral case, the optical modes a and b correspond to polarization $e_{\sigma^{\pm}}$, enabling σ^{\pm} transitions between two atomic levels. If we only excite the a mode through a_{in} , as shown in Fig. 3, we can

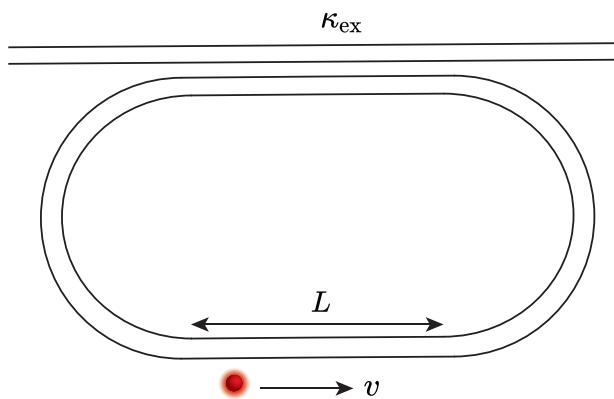

FIG. 2. A racetrack microcavity, where an atom traverses the longest dimension with speed v , and the transverse velocities have been made sufficiently low through a prior stage of atomic beam collimation. Similar considerations for a single-sided Fabry-Perot cavity (e.g., based on a photonic-crystal geometry [26]) hold.

ignore the dynamics of the b mode (assuming a and b are not coupled). Moreover, the phase of the cavity electric field ϕ , appearing in the atom-cavity coupling $g = |g|e^{i\phi}$, can be absorbed into a redefinition of the cavity mode operator a . For the perfectly nonchiral case, the optical modes a and b correspond to polarization e_z , enabling a π transition between two atomic levels. In that case, as we will discuss below Eq. (3), the phase of the cavity field can also be absorbed into a redefinition of the optical modes, giving us a real g .

We next qualitatively consider the extent to which real devices will exhibit perfect chirality/nonchirality. For photonic

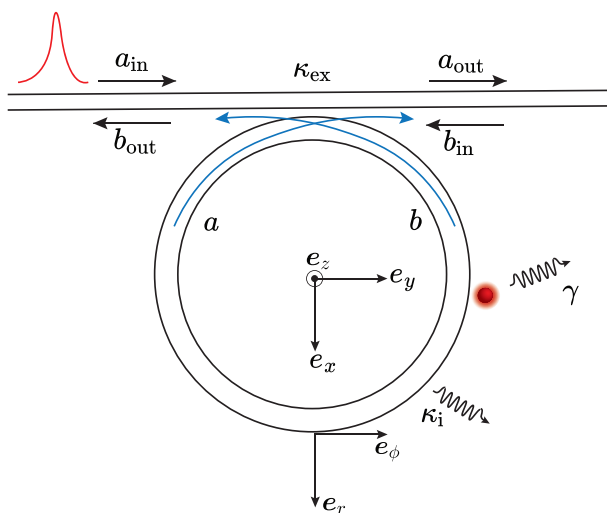

FIG. 3. A schematic diagram of a microring, microbottle, or microtoroid cavity. Input fields a_{in} and b_{in} couple to the cavity with rate κ_{ex} . The cavity has an intrinsic loss rate κ_i . The input and output single-photon fields obey $a_{out} = a_{in} + \sqrt{2\kappa_{ex}}a$ and $b_{out} = b_{in} + \sqrt{2\kappa_{ex}}b$. In the perfectly chiral case, the atom is coupled to the mode a (b) that enables the σ^+ (σ^-) transition, and the atomic state is initialized to the lower level of the appropriate transition (see Ref. [41] as an example). In the perfectly nonchiral case, the atom is coupled to both cavity modes that enable π transitions between the two atomic states, and the atomic state is initialized to the lower level of the appropriate atomic transition.

integrated circuit resonators such as those studied in this work, the transverse electric polarization is typically defined as having its dominant electric field component along the radial direction of the resonator (e_r direction in Fig. 3), while the transverse magnetic polarization has its dominant electric field component orthogonal to the plane of the resonator (i.e., along e_z direction in Fig. 3). Despite the above general designations, it has been shown that, depending on resonator geometry and refractive index, significant longitudinal electric field components can be present, enabling chiral behavior to be realized. Outside of photonic integrated circuits, this has been shown by Rauschenbeutel and colleagues for geometries such as microbottle resonators, where one of the two polarizations can have a significant longitudinal component, corresponding (approximately) to the perfectly chiral modes a , b with polarizations e_{σ^\pm} , while the other polarization is best described as the perfectly nonchiral modes a , b with polarization e_z [42,43]. In contrast, for the higher-refractive-index-contrast, smaller-mode-volume systems that are the focus of our study, both polarizations can have significant longitudinal components due to strong transverse field confinement [44–46]. Therefore, the cavities considered here can have significant longitudinal field components with a $\pm\pi/2$ phase shift, so that, in general, the field is elliptically polarized, with specific spatial locations providing perfect circular polarization. For example, for the microring and microdisk resonators, due to the azimuthal symmetry, the degree of circular polarization varies in the r - z plane. Because our work is focused on thermal atomic beams, individual atoms within the beam will experience differing levels of circular polarization, so our considerations for the perfectly chiral and perfectly nonchiral configurations represent limiting cases. That being said, recent work has shown that through geometric engineering (e.g., of the waveguide cross section), a strong overall degree of circular polarization within the evanescent tail of a propagating waveguide mode can be achieved, even in an average sense, with chiral effects in atomic vapors coupled to such waveguides shown [45]. From this point forward, we will use “chiral” to refer to the perfectly chiral case and “nonchiral” to refer to the perfectly nonchiral case.

Designing an appropriate system for our applications will involve optimizing several design features. Using atomic beam collimators [30] and adjusting the cavity orientation accordingly ensures that the atoms traverse the longest dimension of the cavity. Choosing a specific geometry that maximizes the interaction length L and hence the transit time $\tau \sim L$ —such as in racetrack microcavities [17] shown in Fig. 2 and one-dimensional (1D) Fabry-Perot cavities with Bragg mirrors [47]—comes at the cost of a lower g because $g \sim L^{-1/2}$. As emphasized in the later sections, while the fidelity of our operations increases for larger values of g , we will have to balance this with a competing design goal of having a large enough τ so that a sufficient number of useful operations can be carried out per transit event.

III. CONSIDERATIONS SPECIFIC TO WARM ATOMS

In this section, we briefly summarize the main challenges in using warm atoms to implement the high-fidelity operations mentioned earlier. The first challenge is that warm atoms have

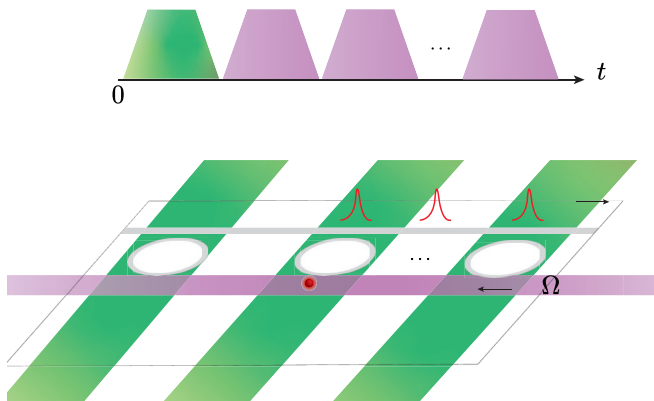

FIG. 4. Before implementing any atom-photon interactions, classical laser pulses (shown in green) can be used to check which cavity is active and measure the single-photon Rabi frequency g . In this figure, we show the example of single-photon generation where the middle cavity is found to be active, and the remaining time slots are used for single-photon retrieval using the classical control pulses Ω .

a limited transit time, thereby limiting the number of useful atom-light interactions that can occur during a given atom's transit. This can be addressed by reducing the timescales over which our atom-light interactions take place; i.e., we choose values of T (the pulse length of single photons) that are much smaller than the transit time τ . For example, producing single photons at cavity resonance with high efficiency η requires the adiabatic limit $\alpha \equiv \kappa T \gg 1$ (assuming $\kappa_i = 0$ for simplicity, so $\kappa = \kappa_{\text{ex}}$), giving us (see Sec. IV)

$$g^2 = \alpha \left(\frac{\gamma}{T} \right) \left(\frac{\eta}{1-\eta} \right) \gg \left(\frac{\gamma}{T} \right) \left(\frac{\eta}{1-\eta} \right). \quad (1)$$

This relation follows from expressing g^2 in terms of the cooperativity as $g^2 = C\kappa\gamma$. Substituting $C = \eta/(1-\eta)$ [which follows from $\eta = C/(1+C)$], as discussed in Sec. IV, and using $\alpha = \kappa T$ to eliminate κ gives us the desired expression. Choosing both $T \ll \tau$ for room-temperature atoms and values of η approaching 1 requires large values of g , which have only recently become routinely available [48]. The second challenge is the temporal variation in coupling strength g as the atom passes through the cavity mode. This is mitigated by using a tightly collimated beam [30] transiting over a particular orientation of the cavity, so the change in g is minimal. The third challenge is that significant Doppler shifts of the cavity field and control pulses can decrease the fidelity of the proposed operations. We show in Sec. IV C how to ameliorate this issue.

Since atom-cavity interactions will be nondeterministic, we propose using multiplexing to implement high-efficiency operations. Multiplexing schemes have already been developed to deal with the dead time of photodetectors. For example, in spatial multiplexing [49], a switching network monitors which detectors in a detector array have recently fired and routes the input pulse into those that have not. As shown in Fig. 4, the analogous procedure here would be to use classical pulses to detect which cavities are active (have an atom in them) and to route the incoming single photon to an active cavity. For single-photon sources, we can consider

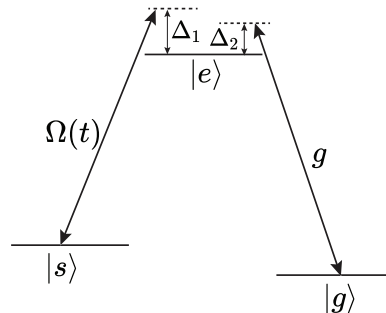

FIG. 5. Atomic levels $|s\rangle$ and $|e\rangle$ are coupled by a classical laser pulse with Rabi frequency $\Omega(t)$, while atomic levels $|e\rangle$ and $|g\rangle$ are coupled by the cavity with single-photon Rabi frequency g .

a protocol that detects the presence of an atom in the cavity prior to applying the control pulse, producing a heralded single photon. This is feasible since state-of-the-art on-chip modulators feature switching times of <30 ps [50], which is much shorter than the achievable transit time τ (~ 10 ns, as shown in Table I) and single-photon duration T (few nanoseconds, as shown in Table I). In addition, we can also consider checking whether a given cavity is still active at the end of our operation. We will also consider “passive” multiplexing wherein we can simply use a large number of cavities to make atom-photon interactions more probable, at the cost of effectively increasing the intrinsic loss κ_i .

IV. SINGLE-PHOTON GENERATION AND DETECTION

In this section, we outline the coherent control technique that can be used to generate and absorb single photons using a Λ -type atom coupled to a cavity [51]. We also study in detail how various parameter regimes determine the properties of single photons that can be generated and absorbed.

As shown in Fig. 5, the cavity couples atomic states $|e\rangle$ and $|g\rangle$ with single-photon Rabi frequency g , and the classical laser pulse couples atomic states $|e\rangle$ and $|s\rangle$ with Rabi frequency $\Omega(t)$. In a rotating frame, the Hamiltonian within the rotating-wave approximation is (we set $\hbar = 1$ throughout most of the article)

$$H = -\Delta_2|e\rangle\langle e| + (\Delta_1 - \Delta_2)|s\rangle\langle s| + (ga|e\rangle\langle g| + \Omega|e\rangle\langle s| + \text{H.c.}), \quad (2)$$

where a denotes the annihilation operator for the cavity field mode. Here, $g = -\langle e|\mathbf{d} \cdot \boldsymbol{\epsilon}_c|g\rangle\mathcal{E}_c/\hbar$ denotes the single-photon Rabi frequency, where \mathcal{E}_c and $\boldsymbol{\epsilon}_c$ are the amplitude and the polarization of the single-photon electric field, respectively, and \mathbf{d} is the atomic dipole moment operator. Similarly, $\Omega = -\langle e|\mathbf{d} \cdot \boldsymbol{\epsilon}_p|s\rangle\mathcal{E}_p/2\hbar$ is the classical Rabi frequency, where \mathcal{E}_p and $\boldsymbol{\epsilon}_p$ are the amplitude and the polarization of the classical laser pulse, respectively. Here, H.c. denotes the Hermitian conjugate of the preceding two terms. The detunings Δ_1 and Δ_2 are defined by $\Delta_1 = \omega_1 - \omega_{es}$ and $\Delta_2 = \omega_c - \omega_{eg}$, respectively, where ω_1 is the control laser frequency, ω_c is the cavity field frequency, ω_{es} is the frequency of the e - s transition, and ω_{eg} is the frequency of the e - g transition. This Hamiltonian is realized for both perfectly chiral and perfectly nonchiral polarizations of the cavity modes, as discussed in Sec. II.

TABLE I. Examples of various system parameters for case 1 (maximizing the efficiency for unlimited control power), where g is the single-photon Rabi frequency, κ_{ex} is the rate at which the microcavity couples to the waveguide, κ_i is the microcavity's intrinsic loss, 2γ is the decay rate of the state e , $C = g^2/\kappa\gamma$ is the cooperativity ($\kappa = \kappa_{\text{ex}} + \kappa_i$), and T is the single-photon duration. The photons have frequency ω_c . The angular frequencies and times have units of (2π) GHz and ns, respectively. \mathcal{F} is the single-photon fidelity, and \mathcal{F}_{en} is the atom-photon entangling gate fidelity. Here, η_{abs} is the probability of measuring the state s following the absorption of the single photon, and η_d is the probability of detecting the correct atomic state using the controlled-phase-gate-based single-photon detection. Increasing the cavity length decreases g and increases the transit time τ . Parameters of cavities 1a–1c correspond to silicon nitride microdisk optical resonators [57]; the parameters of cavities 2a and 2b correspond to higher refractive index silicon carbide microdisk optical resonators [58]; and the parameters of cavities 3 and 4 correspond to silicon nitride photonic-crystal cavities in Ref. [26].

Setup		g	κ_{ex}	κ_i	2γ	C	Ω_0	$1 - \mathcal{F}$	$1 - \mathcal{F}_{\text{en}}$	$1 - \eta_{\text{abs}}$	$1 - \eta_d$	T	τ	τ/T
Model cavities	Cavity 1a	1.6	5	0.01	0.0061	167	0.4	0.024	0.18	0.024	0.17	2.22	13.7	6
	Cavity 1b	1.6	5	0.05	0.0061	166	0.4	0.032	0.19	0.032	0.19	2.22	13.7	6
	Cavity 1c	1.6	3	0.01	0.0061	280	0.5	0.02	0.05	0.02	0.04	3.40	13.7	4
	Cavity 2a	4.7	7	0.01	0.0061	1030	2.0	0.004	0.026	0.004	0.011	1.30	5.20	4
	Cavity 2b	2.0	6	0.01	0.0061	220	0.6	0.025	0.18	0.025	0.17	1.70	13.7	8
	Cavity 3	17	27	0.15	0.0061	3500	7.0	0.010	0.062	0.010	0.031	0.24	1.3	5
	Cavity 4	8	20	0.15	0.0061	1040	3.0	0.011	0.14	0.011	0.12	0.43	1.3	3

In the perfectly chiral case, the transition dipole moment is oriented such that the cavity electric field enables a σ^\pm transition between the atomic states $|g\rangle$ and $|e\rangle$. In the perfectly nonchiral case, wherein the atom couples equally strongly to both clockwise and counterclockwise modes of the resonator (a and b), the atom-cavity interaction is given by [52]

$$H_{\text{int}} = (ga + g^*b)|e\rangle\langle g| + \text{H.c.}, \quad (3)$$

which can be reduced to Eq. (2) by redefining $\frac{1}{\sqrt{2}}(e^{i\phi}a + e^{-i\phi}b) \rightarrow a$, where $g = |g|e^{i\phi}$, and then redefining $\sqrt{2}g \rightarrow g$. After absorbing the phase of g in the cavity mode operator ($\propto e^{i\phi}a + e^{-i\phi}b$), we can take g to be real. In this case, the transition dipole is oriented such that the cavity field enables a π transition. We will therefore focus on Eq. (2). Additionally, we restrict our analysis to the radiatively limited case, where both optical coherences decay with rate γ , determined purely by the spontaneous emission rate of state $|e\rangle$. Our analysis can be extended to include additional dephasing of the g - e and g - s coherences [by adding additional decay rates to Eqs. (A2) and (A1), respectively]. We leave the problem of implementing single-photon retrieval and absorption in resonators with arbitrary polarization for future work.

Coupling the atom to the cavity allows for the use of the laser pulse $\Omega(t)$ to drive a Raman process that can generate or absorb single photons [53,54]. For single-photon generation, the system starts in state $|s, 0\rangle$ and is driven to state $|g, 1\rangle$ via a Raman process, where $|x, n\rangle$ denotes the joint atom-cavity state with the atom in state x and the cavity in the n -photon number state. The cavity photon (1 in $|g, 1\rangle$) is emitted into the waveguide. Similarly, for single-photon detection, the input photon in the waveguide populates state $|g, 1\rangle$. The control pulse enables a Raman transition that drives state $|g, 1\rangle$ to state $|s, 0\rangle$ with $|e, 0\rangle$ as the intermediate state. As discussed later in this section, measurement of the atomic state can be performed by sending weak coherent light into the cavity and measuring the phase of the transmitted light. The duration of the input pulses is the same as the single-photon duration T chosen for the system parameters.

Using the method from Ref. [55], we can compute, exactly, the control pulse $\Omega(t) = \Omega_0(t)e^{i\phi_0(t)}$ (for arbitrary detuning Δ_2) required to generate a single photon with (normalized) mode shape $h(t)$, time duration T , and frequency $\omega_c + \Delta_p$, such that $a_{\text{out}} = \sqrt{2\kappa_{\text{ex}}}c_g(t) = \sqrt{\eta_r}h(t)e^{-i\Delta_p t}$, where, as shown in Fig. 3, a_{out} is the mode corresponding to the outgoing photon and is normalized as $\int dt |a_{\text{out}}|^2 = \eta_r$. Here, c_g is the amplitude of the state $a^\dagger|g, 0\rangle = |g, 1\rangle$, and η_r is the efficiency of the single-photon generation (i.e., retrieval efficiency). Assuming that we choose $\Delta_1 = \Delta_2 + \Delta_p$, the phase ϕ_0 is a slowly varying function. The exact expressions for $\Omega_0(t)$ and $\phi_0(t)$ are given in Appendix A. To find analytic expressions for the required control Rabi frequency and the protocol's maximum efficiency η_{max} , we consider the adiabatic limit ($\kappa_{\text{ex}}T \gg 1$) to get

$$\Omega_0(t) = \frac{\xi}{g} \frac{A(t)}{[1 - (\eta_r/\eta_{\text{max}}) \int_0^t h^2 dt']^{1/2}}, \quad (4)$$

$$\xi^2 = (g^2 - \Delta_p^2 - \Delta_2\Delta_p + \kappa\gamma)^2 + [-\kappa(\Delta_p + \Delta_2) - \gamma\Delta_p]^2, \quad (5)$$

$$A(t) = \sqrt{\frac{\eta_r}{2\kappa_{\text{ex}}}}h(t), \quad (6)$$

$$\eta_{\text{max}} = \frac{\kappa_{\text{ex}}}{\kappa} \left[1 + C^{-1} + \frac{\gamma}{\kappa} \left(\frac{\Delta_p}{g} \right)^2 \right]^{-1}, \quad (7)$$

where 2γ is the decay rate of the state $|e\rangle$, $\kappa = \kappa_i + \kappa_{\text{ex}}$, and $C = g^2/\kappa\gamma$ is the cooperativity parameter. The corresponding expression for the phase of the control pulse $\phi_0(t)$ can be found in Eqs. (A10)–(A12) in Appendix A. In Eqs. (4)–(7), η_r is a free parameter that can be chosen from zero to a value arbitrarily close to η_{max} , but the closer it is to η_{max} , the larger the value of the control pulse becomes near $t = T$. Moreover, numerics show that the exact profile for $\Omega_0(t)$ (computed without the adiabatic condition) for a Gaussian-like mode is nondivergent near $t = T$ even as η_r becomes arbitrarily close to η_{max} as long as we keep increasing $\kappa_{\text{ex}}T$ as we take η_r closer to η_{max} (the divergence here corresponds physically to the depletion of the amplitude in state $|g, 1\rangle$). In practice,

we can either choose $\eta_r = \eta_{\max}$ and truncate the control pulse near $t = T$ or choose $\eta_r < \eta_{\max}$ and avoid the truncation. We remark that outside the limit $\kappa_{\text{ex}}T \gg 1$, we can compute η_{\max} and the corresponding control pulse using numerical methods like gradient descent [56].

We also note that here we calculate the control pulse that (without truncation) retrieves a single photon exactly into the desired mode $h(t)$ with efficiency η_r , while the remaining fraction $1 - \eta_r$ gets scattered via γ , lost via κ_i , or remains in $|s\rangle$. For many application purposes, a more relevant calculation would instead solve for the control pulse that maximizes the overlap of the output mode with the target mode $h(t)$, without asking for the output mode to be exactly $h(t)$. Such a calculation is difficult to do analytically since it requires an expression for a_{out} in terms of the control pulse $\Omega(t)$ in the strong-coupling regime. At the same time, we expect that such a modified calculation will typically not give a qualitative improvement in the overlap efficiency compared to the optimization we use.

We now wish to compute the reduction of efficiency below η_{\max} due to insufficient control pulse power instead of fixing the value of η_r and assuming unlimited control pulse power as in Eqs. (4)–(7). We can compute the retrieval efficiency in the limit $\kappa_{\text{ex}}T \gg 1$ as follows:

$$\eta_r = \eta_{\max} (1 - e^{-2\kappa_{\text{ex}}g^2 f(0,T)/(\eta_{\max}\xi^2)}), \quad (8)$$

where

$$f(t, t') = \int_t^{t'} \Omega_0^2(t'') dt''. \quad (9)$$

Note here that the quantity in the exponent of Eq. (8) depends on the frequency of the single photon retrieved [through ξ in Eq. (5)] and therefore determines how large the deviation of η_r from η_{\max} is for a given value of $f(0, T)$. For the rest of the article, we consider the case $\Delta_2 = 0$, i.e., when the cavity is resonant with the e - g transition. Assuming $C \gg 1$, the quantity in the exponent simplifies to

$$\frac{g^2 f(0, T)}{\xi^2} = \frac{f(0, T)}{g^2 R(x)}, \quad (10)$$

$$R(x) = (1 - x^2)^2 + x^2(\kappa^2 + \gamma^2)/g^2 + 2C^{-1}, \quad (11)$$

where $x = \Delta_p/g$. In the following subsections, we will make use of this expression to analyze the dependence of efficiency on the available control power.

In single-photon absorption, we start with the state $|g, 0\rangle$ with an incoming single photon in the waveguide and end in the state $|s, 0\rangle$. This process corresponds qualitatively to the time-reversed version of the retrieval (single-photon generation) process. However, since the retrieval process ends with a small amplitude in the state $|s, 0\rangle$ (with an outgoing photon in the waveguide) while the absorption process starts with all of the amplitude in the state $|g, 0\rangle$ (with an incoming photon in the waveguide), the two processes are not exactly time-reversal symmetric. Numerical results show that the time-reversed version of the retrieval protocol [i.e., $\Omega(t) \rightarrow -\Omega(T - t)^*$] with retrieval efficiency η_r gives approximately the same absorption efficiency $\eta_{\text{abs}} = |c_s(T)|^2$ as the retrieval efficiency, where $c_s(t)$ is the amplitude of the state $|s, 0\rangle$ at time t and T is the single-photon duration.

We will now study single-photon generation (i.e., retrieval) in two cases: In case 1, we will maximize the efficiency for unlimited control power, while in case 2, we will maximize the efficiency for limited control power.

Case 1: Maximizing the efficiency for an unlimited control power

In case 1, we consider maximizing the retrieval efficiency assuming unlimited control power. We suppose that the adiabatic condition $\kappa_{\text{ex}}T \gg 1$ is satisfied, so that Eqs. (4)–(7) hold. To maximize η_{\max} in Eq. (7), we set $\Delta_p = 0$ to get the maximum efficiency:

$$\eta_{\max}^{(1)} = \frac{\kappa_{\text{ex}}}{\kappa} [1 + C^{-1}]^{-1}. \quad (12)$$

The retrieval efficiency can then be written as

$$\eta_r = \eta_{\max}^{(1)} (1 - e^{-2\kappa f(0,T)[1-C^{-1}]/g^2}). \quad (13)$$

We now consider how the single-photon duration T scales with the maximum control pulse size Ω_0 and other physical parameters. We fix a value of η_r close to $\eta_{\max}^{(1)}$ in Eq. (13) and find the following scaling:

$$\Omega_0^2 \sim \frac{g^2}{\kappa T}, \quad (14)$$

which implies that, for a large fixed value of κT , $\Omega_0 \sim g$. In the case $\kappa_i = 0$ ($\kappa = \kappa_{\text{ex}}$), the leading error term for single-photon retrieval and absorption scales favorably as C^{-1} . In the case where κ_i is nonzero, the leading error term (ignoring higher orders in C^{-1}) is instead $\kappa_i/\kappa + (\kappa_{\text{ex}}/\kappa)C^{-1}$. We note here that, while choosing $\kappa_{\text{ex}} = \sqrt{g^2\kappa_i/\gamma} - \kappa_i$ minimizes the error, this choice is only practical as long as κ_{ex} is large enough to satisfy both $\kappa_{\text{ex}}T \gg 1$ and $T \ll \tau$. We remark here that, based on Eq. (14), both g and $\kappa_{\text{ex}}T$ determine how large the required control Rabi frequency Ω_0 is, and therefore how feasible the scheme is.

In Table I, we present results for exemplary parameter regimes wherein we can achieve both $C \gg 1$ and $\kappa_{\text{ex}}T \gg 1$ (and hence high efficiencies for single-photon sources and detectors) and also satisfy $T \ll \tau$. Here, the single-photon fidelity \mathcal{F} is defined as $\mathcal{F} = \langle \psi | \rho | \psi \rangle$, where ρ is the output state and $|\psi\rangle$ is the target state. For model cavities in Table I, parameters of cavities 1a–1c correspond to silicon nitride microdisk optical resonators [57], and parameters of cavities 2a and 2b correspond to higher refractive index silicon carbide microdisk optical resonators [58]. The parameters in cavities 3 and 4 correspond to silicon nitride photonic-crystal cavities in Ref. [26] with mode volumes on the order of $\sim(\lambda/n_r)^3$, where λ is the free-space wavelength and n_r is the material's refractive index. Here, values of κ_i are consistent with theoretically predicted quality factors in such cavity types, and in some cases, such values have been approached experimentally. The values of κ_{ex} correspond to cases wherein the cavities have strong overcoupling ($\kappa_{\text{ex}} \gg \kappa_i$) with a bus waveguide. The values of the classical Rabi frequency correspond to optical intensities ($\sim 10^3 q^2 \text{ W cm}^{-2}$, where q is the size of the Rabi frequency Ω_0 in GHz, for the atomic level scheme proposed in Sec. IV A) achievable on chip because laser power in a waveguide is confined to sub- μm^2 area.

We first note that, since we have high values of g , we can choose $\kappa_{\text{ex}} > g$ so that the single-photon duration T is small

while keeping the cooperativity large (as in cavity 1a). In general, this helps us maximize the number of single-photon pulses that we can generate during an atomic transit. We first examine the role of intrinsic loss κ_i by comparing cavity 1b to cavity 1a and see that, even in this regime where C is only marginally impacted, larger κ_i causes a reduction in single-photon fidelity. As shown in model cavity 1c, we can also decrease κ_{ex} in favor of a larger cooperativity. However, this leads to larger values of single-photon duration to satisfy $\kappa_{\text{ex}}T \gg 1$, and hence a lower number of photons produced per transit event. We can also decrease the value of g in favor of a longer cavity length and a longer transit time, as shown in model cavities 2a and 2b. However, this requires reduced values of κ_{ex} accordingly to maintain high cooperativity, which also means we will need larger values of single-photon duration T to satisfy $\kappa_{\text{ex}}T \gg 1$. Finally, cavities 3 and 4 show performance with a very limited transit time (e.g., in the limit of no beam collimation), where large g and κ_{ex} can enable a few high-fidelity operations to be performed. In Appendix E, we study how the aforementioned performance metrics are enhanced by using various atomic cooling techniques.

Case 2: Maximizing the efficiency for a limited control pulse size

We now consider case 2, i.e., when we have a limited control pulse size and $\kappa_{\text{ex}}T \gg 1$. We can then maximize η_r in Eq. (8) with respect to $x = \Delta_p/g$ for a given value of $f(0, T)$. However, instead of maximizing the full expression for η_r (which depends on η_{max} and the value of the exponential), we note that minimizing just the value of the exponential for the parameters considered gives approximately the same efficiency. This is because, for limited $f(0, T)$, the retrieval efficiency is more sensitive to a non-negligible value of the exponential than to a smaller value of η_{max} (which is always close to 1 for $C \gg 1$, $\kappa_i \ll \kappa_{\text{ex}}$, $\gamma/\kappa \ll 1$, and $|x| < 1$). Then, for $\kappa^2 + \gamma^2 < 2g^2$, Eqs. (8)–(11) show that we can choose the single-photon frequency $\Delta_p = x_0g$ [where $\pm x_0$ are the minima of $R(x)$ in Eq. (11)] such that

$$x_0 = \pm \sqrt{1 - \frac{\kappa^2 + \gamma^2}{2g^2}}, \quad (15)$$

$$\Delta x \sim \frac{2\kappa}{\sqrt{4g^2 - \kappa^2}}, \quad (16)$$

where Δx is the width around the minima of $R(x)$. The correction to the efficiency due to finite control pulse power (in the limit $\kappa_{\text{ex}}T \gg 1$) can then be computed from Eq. (8) as follows:

$$\eta_r = \eta_{\text{max}}^{(2)} \left(1 - e^{-2\kappa_{\text{ex}}f(0,T)/(\eta_{\text{max}}^{(2)}(\kappa + \gamma)^2)} \right), \quad (17)$$

where the maximum efficiency is now

$$\eta_{\text{max}}^{(2)} = \frac{\kappa_{\text{ex}}}{\kappa} \left[1 + C^{-1} + x_0^2 \frac{\gamma}{\kappa} \right]^{-1}, \quad (18)$$

where we note that the maximum achievable efficiency is smaller than the one from case 1 in Eq. (12). Moreover, we get the following scaling for T :

$$\Omega_0^2 \sim \frac{(\kappa + \gamma)^2}{\kappa T}, \quad (19)$$

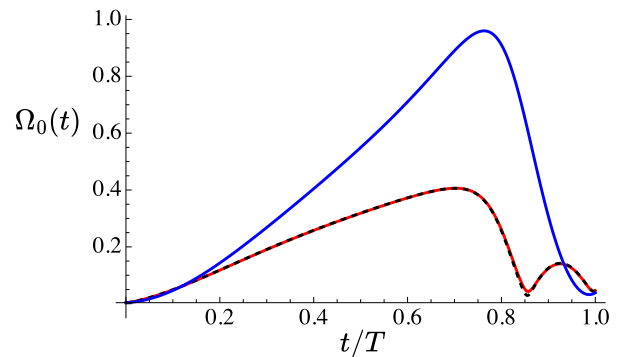

FIG. 6. Size of control pulse $\Omega_0(t)$ [in (2π) GHz] used to retrieve a single photon with mode shape $\propto \sin^2(\pi t/T)$ with system parameters $(g, \kappa_{\text{ex}}, \kappa_i, 2\gamma) = 2\pi(1.6, 0.9, 0.01, 0.0061)$ GHz. The blue line is for case 1 ($\Delta_p = 0$) with efficiency $\eta_r = 0.979$. The red line is for case 2 with the value of $\Delta_p = -x_1g$ obtained through numerical maximization of η_r in Eq. (8) with respect to Δ_p with $f(0, T) = 1.34g$ achieving $\eta_r = 0.979$. The dashed black curve is for case 2 with the value of $\Delta_p = -x_0g$ with the same value of $f(0, T)$. As seen from Eq. (13), $f(0, T)/(g^2/2\kappa) = 1.53$ shows that photons cannot be retrieved (with high efficiency) for this value of $f(0, T)$ at the cavity resonance frequency. Moreover, as seen from Eq. (17), $f(0, T)/((\kappa + \gamma)^2/(2\kappa_{\text{ex}})) = 8.84 \gg 1$, which explains why photons can be retrieved at frequency $\Delta_p = -x_0g$ with high efficiency.

implying that, for some large fixed value of κT , $\Omega_0 \sim (\kappa + \gamma)$. When we choose $x = x_0 \approx 1$ ($\Delta_p \approx g$), the state $|+\rangle \propto |e, 0\rangle + |g, 1\rangle$ is coupled resonantly to the state $|s, 0\rangle$, which allows us to adiabatically eliminate the state $|-\rangle \propto |e, 0\rangle - |g, 1\rangle$. Physically, this corresponds to addressing one of the eigenstates of the atom-cavity Hamiltonian. This explains why we have a lower value of η_{max} in case 2 compared to case 1, since the $|e, 0\rangle$ state gives an additional contribution to the decay. One advantage of case 2 is that we get a better scaling for Ω_0 ($\Omega_0 \sim \kappa + \gamma$) compared to case 1 (where $\Omega_0 \sim g$) in that we need smaller control pulse sizes since $(\kappa + \gamma) \ll g$ can be easily achieved in the strong-coupling regime in experiment. However, one disadvantage of case 2 is that the photons retrieved cannot be used for implementing the atom-photon controlled-phase gate, as they are off resonant (by approximately $\pm g$) from the cavity resonance frequency. Instead, in the limits $\kappa_i \ll \kappa_{\text{ex}}$, $g \gg \gamma$, the atom-cavity interaction implements the following atom-photon gate:

$$W = Z_p \text{CP}(\phi), \quad (20)$$

where $Z_p = \text{diag}(1, -1)$ in the basis $\{|v\rangle, |h\rangle\}$, $\text{CP}(\phi) = \text{diag}(1, 1, 1, e^{i\phi})$ in the basis $\{|gv\rangle, |gh\rangle, |sv\rangle, |sh\rangle\}$, and $\phi = 2\pi - 2 \arctan(g/\kappa_{\text{ex}})$. The derivation of this gate follows from Eq. (B9). Since the value of g fluctuates with the atomic position, we leave it as an open question whether a changing but known value of ϕ (obtained by monitoring the atomic position) in the $\text{CP}(\phi)$ gate can be used to perform universal quantum computation. In Fig. 6, we compare the control pulses $\Omega_0(t)$ for the two cases, $x = 0$ (case 1) and $x = x_0$ (case 2). In this example, for case 2, we also compare two different control pulses. The first control pulse is obtained from setting $x = x_0$, producing a single photon with the corresponding value of $f(0, T) = f_0$. The second control pulse

TABLE II. Examples of various system parameters for case 2 (maximizing the efficiency for a limited control pulse size), where g is the single-photon Rabi frequency, κ_{ex} is the rate at which the microcavity couples to the waveguide, κ_i is the microcavity's intrinsic loss, 2γ is the decay rate of state $|e\rangle$, $C = g^2/\kappa\gamma$ is the cooperativity ($\kappa = \kappa_{\text{ex}} + \kappa_i$), T is the single-photon duration, and $\Delta_p = -gx_0$. The angular frequencies and times have units of (2π) GHz and ns, respectively. Here, \mathcal{F} is the single-photon fidelity, and η_{abs} is the probability of measuring the state s following the absorption of the single photon. Increasing the cavity length decreases g . The maximum size of the control pulse for case 2, $\tilde{\Omega}_0$, is compared with the maximum size of the control pulse from case 1, $\tilde{\Omega}_0$, used to retrieve/absorb single photons with the same parameters and frequency resonant with the cavity (i.e., $\Delta_p = 0$). Parameters of cavity 5 correspond to silicon nitride microdisk optical resonators [57], and the parameters of cavities 6 and 7 correspond to silicon nitride photonic-crystal cavities in Ref. [26].

Setup		g	κ_{ex}	κ_i	2γ	C	Ω_0	$\tilde{\Omega}_0$	$1 - \mathcal{F}$	$1 - \eta_{\text{abs}}$	T	τ	τ/T
Model cavities	Cavity 5	1.6	0.9	0.01	0.0061	920	0.4	1.0	0.021	0.021	4.42	13.7	3
	Cavity 6	17	12	0.15	0.0061	7800	5.4	12.0	0.014	0.014	0.42	1.3	3
	Cavity 7	8	6	0.15	0.0061	3400	3.0	6.0	0.027	0.027	0.64	1.3	2

is obtained from the value of x that maximizes η_r in Eq. (8) for $f(0, T) = f_0$. The values of x are close ($x_0 = 0.916$, while numerical maximization gives $x = 0.894$).

We now consider the dominant errors for case 2. First, consider the situation where $\kappa_i = 0$. In this case, Eq. (7) shows that the dominant inefficiency is $x_0^2(\gamma/\kappa) + C^{-1}$. In the situation where $\kappa_i \ll \kappa_{\text{ex}}$, Eq. (7) shows that the dominant inefficiency is $(\kappa_i + x_0^2\gamma)/\kappa_{\text{ex}} + (\kappa_{\text{ex}}/\kappa)C^{-1}$.

We can choose a value of κ_{ex} based on experimental constraints, e.g., minimizing the control pulse size or minimizing photon pulse duration T with $\kappa_{\text{ex}}T \gg 1$, while keeping κ small enough to be consistent with Eq. (15). In the examples considered in Table II, we show parameters with near-ideal efficiencies and $T \ll \tau$. In the table, we also compare the maximum sizes of the control pulse needed to retrieve/absorb photons with given efficiencies using control pulses from cases 1 and 2. In Fig. 7, we show the retrieval of a single photon with system parameters from model cavity 5 in Table II.

We now outline our scheme to measure the atomic state using weak coherent light pulses of duration T' and with some chosen detuning relative to the cavity and atomic frequencies. In the first step, we send a pulse that discriminates between the state g and the case where the atom is in the state s or absent. If the phase of the output light corresponds to the transmission coefficient of an atom strongly coupled to a cavity, we obtain a measurement of the state g . If instead, the output light corresponds to that of an empty cavity, we perform two fast π pulses along the s - e' and e' - g transitions that map the state s to the state g , where the e' - g transition does not couple to the cavity. A second light pulse is then sent into the system. If the phase measurement corresponds to the strongly coupled case, we obtain a measurement of the state s . Finally, a phase measurement corresponding to an empty cavity indicates that the atom is absent. The duration T' can be chosen as $T' = T$ to satisfy the adiabatic limit, where T is the single-photon pulse duration used in our protocols. Moreover, the time required to perform fast π pulses can be chosen to be $\ll T$.

A. Atomic level scheme

We study the two cases, i.e., the case where the optical modes are perfectly chiral, assuming the mode a has perfect circular polarization, and the case where the optical modes are perfectly nonchiral, assuming the modes a and b have perfectly linear polarization. In the chiral case, the

single photon is retrieved and absorbed into mode a_{out} . However, in the nonchiral case, the single photon is retrieved and absorbed into the mode $\propto (e^{i\phi}a + e^{-i\phi}b)$, where ϕ is the phase defined in Eq. (B16). In the case of retrieval, we can use the position measurement of the atom to determine the phase ϕ , and then transform the retrieved mode into a_{out} (or b_{out}) using linear optics. Similarly, for absorption, we must first use linear optics to transform the mode we want to be absorbed, say a_{in} , into mode $\propto (e^{i\phi}a_{\text{in}} + e^{-i\phi}b_{\text{in}})$, and then send it to the cavity (and apply the control pulse as described in Sec. IV). We propose using the following atomic level schemes for the chiral and nonchiral cases (as shown in Fig. 8). For the chiral case, we choose ^{87}Rb with $|g\rangle = |5S_{1/2}, F = 2, m_F = 2\rangle$, $|s\rangle = |7S_{1/2}, F = 2, m_F = 2\rangle$,

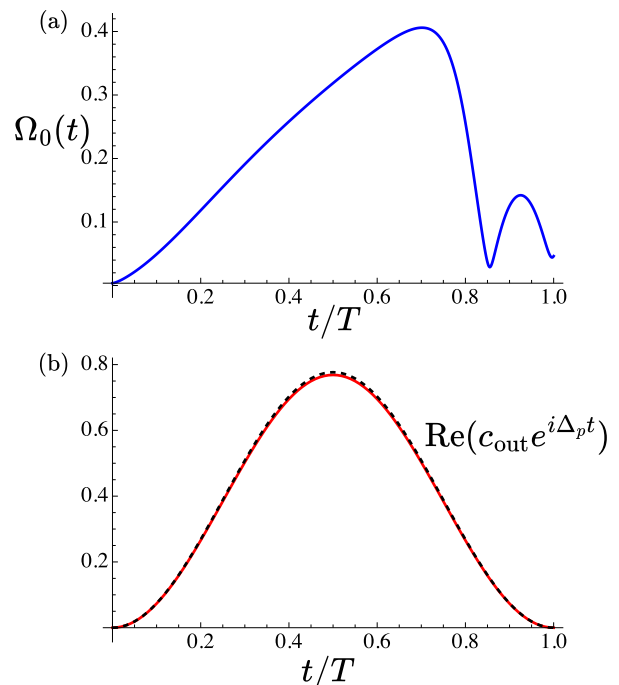

FIG. 7. (a) Size of the control pulse to retrieve a single photon in case 2 ($\Delta_p = -x_0g$) with mode shape $\sin^2(\pi t/T)$ and with system parameters $(g, \kappa_{\text{ex}}, \kappa_i, 2\gamma) = 2\pi(1.6, 0.9, 0.01, 0.0061)$ GHz with $T = 4.42$ ns. (b) The red line corresponds to the real part of $a_{\text{out}}e^{i\Delta_p t} = \sqrt{2\kappa_{\text{ex}}}c_g e^{i\Delta_p t}$, and the dashed black line is the desired mode function $\propto \sin^2(\pi t/T)$. The inefficiency is $1 - \eta_r = 0.021$.

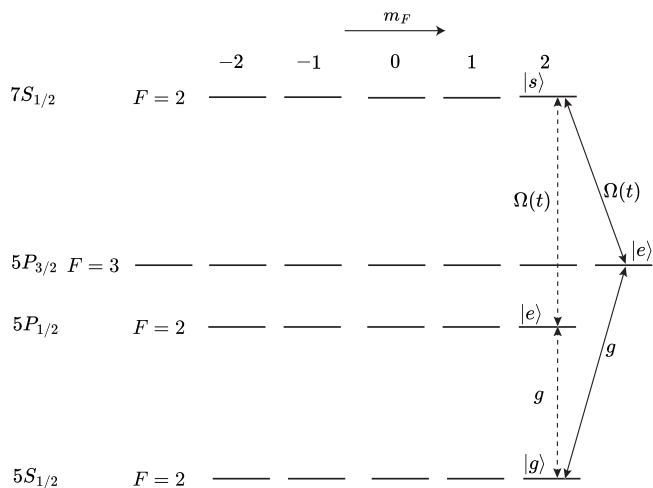

FIG. 8. Proposed atomic level scheme for the chiral case (solid black) and nonchiral case (dashed black). For the chiral case, mode a couples to the σ_+ g - e transition. The s - e transition has wavelength 741 nm, and the e - g transition has wavelength 780 nm. For the nonchiral case, modes a and b couple to the π g - e transition. The s - e transition has wavelength 728 nm, and the e - g transition has wavelength 795 nm. The detunings are defined as $\Delta_1 = \omega_{se} - \omega_1$ and $\Delta_2 = \omega_c - \omega_{eg}$, where ω_{ij} is the energy corresponding to the atomic transition $i \rightarrow j$, ω_1 is the frequency of the control pulse $\Omega(t)$, and ω_c is the cavity resonance frequency.

and $|e\rangle = |5P_{3/2}, F = 3, m_F = 3\rangle$. The s - e transition has wavelength 741 nm, and the e - g transition has wavelength 780 nm. For the nonchiral case, we choose ^{87}Rb with $|g\rangle = |5S_{1/2}, F = 2, m_F = 2\rangle$, $|s\rangle = |7S_{1/2}, F = 2, m_F = 2\rangle$, and $|e\rangle = |5P_{1/2}, F = 2, m_F = 2\rangle$. The s - e transition has wavelength 728 nm, and the e - g transition has wavelength 795 nm.

We now focus on the chiral case where we can ameliorate the effect of large atomic velocities on photon retrieval and absorption. Since the e - g transition has a longer wavelength than the one corresponding to the s - e transition, applying the control pulse at an angle to the cavity, as shown in Fig. 9, can cancel the unwanted contribution to the two-photon detuning caused by the Doppler effect. The chosen state $|s\rangle$ has a lifetime of 88 ns [59], which is much larger than the values of single-photon duration T we consider. While this atomic level scheme is not a lambda-type configuration (it is a ladder configuration), our equations still describe the system (as long as we redefine the detuning Δ_1) since the state $|e\rangle$ still has the dominant decay rate. After redefining Δ_1 to $\omega_{se} - \omega_1$ for the ladder configuration, our control pulse scheme can be used in the same way. The laser and cavity fields are chosen to satisfy $\vec{k}_p \cdot \vec{v} + \vec{k}_c \cdot \vec{v} \approx 0$ (where \vec{k}_p and \vec{k}_c are the wave vectors corresponding to the control pulse and the cavity mode, respectively, and \vec{v} is the velocity of the atom), minimizing the unwanted Doppler contribution to the two-photon detuning $\Delta_1 - \Delta_2$, as described in Fig. 8. The three-level-atom approximation holds because the unwanted off-resonant transitions have large detunings compared to the corresponding Rabi frequencies. For the chiral case, the cavity field is detuned from the $|5D\rangle$ - $|e\rangle$ and $|g\rangle$ - $|5P_{1/2}\rangle$ transitions by $\approx (2\pi)2$ THz and $\approx (2\pi)7$ THz, respectively, with single-photon Rabi

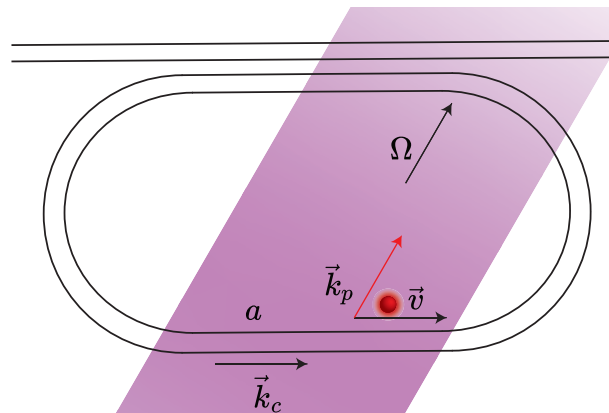

FIG. 9. Scheme for dealing with the Doppler shift. Shown here is a chiral cavity with optical mode a with wave vector \vec{k}_c . The control pulse Ω has the wave vector \vec{k}_p at an angle to the atom's velocity, which is parallel to the microcavity's length. The angle is chosen to cancel the unwanted contribution to two-photon detuning due to the Doppler effect. For a lambda system, the condition $\vec{k}_c \cdot \vec{v} - \vec{k}_p \cdot \vec{v} = 0$ cancels the Doppler contribution to the two-photon detuning. For the ladder system (as in Fig. 8), this condition is modified to $\vec{k}_c \cdot \vec{v} + \vec{k}_p \cdot \vec{v} = 0$.

frequencies comparable to $g \approx (2\pi)10$ GHz. Similarly, the control pulse is detuned from the $|s\rangle$ - $|5P_{1/2}\rangle$ transition by $\approx (2\pi)7$ THz with Rabi frequency comparable to $\Omega \approx (2\pi)10$ GHz. For producing a string of single-photon pulses, we need to reinitialize the state to $|s, 0\rangle$ after each single-photon retrieval (which ends in the state $|g, 0\rangle$). The state can be reinitialized using a pair of π pulses on the transitions $|g\rangle$ - $|5P_{1/2}\rangle$ and $|5P_{1/2}\rangle$ - $|s\rangle$. Finally, we note here that, even when we cannot use the same scheme for a nonchiral system, wherein it is impossible to cancel the Doppler shift to the two optical modes simultaneously for the geometry shown in Fig. 9, it is possible that a high atomic velocity may not be an issue. For instance, if the atom passes transversely to the cavity wave vector, the detunings Δ_1 and Δ_2 will have no Doppler shift contributions.

We now compare the proposed sources and detectors with other platforms. The single-photon detection efficiencies obtained by the cavities discussed in Tables I and II compare well to efficiencies achievable by superconducting nanowire single-photon detectors that can have detection efficiencies of approximately 0.97 at 1500 nm (at 10^5 counts/s) [14]. We then compare the possible single-photon fidelities from our heralded single-photon generation to other available platforms. State-of-the-art spontaneous parametric-down-conversion, quantum-dot, and Rydberg-ensemble platforms can have heralded single-photon fidelities \mathcal{F} of 0.961 [60], 0.972 [61], and 0.982 [62], respectively, where $\mathcal{F} = \langle \psi | \rho | \psi \rangle$, $|\psi\rangle$ is the target state, and ρ is the output state. These are also comparable to single-photon fidelities achievable with the parameters we consider in Tables I and II. For single-photon sources, the constraint on the number of photons produced per atomic transit (given approximately by τ/T) arises from several factors, including the atomic transit time τ , finding feasible values of κ , T that satisfy $\kappa T \gg 1$, $C \gg 1$, and $T \ll \tau$, the feasibility of achieving

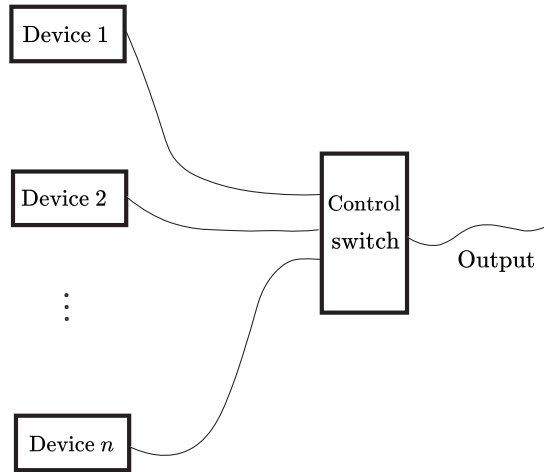

FIG. 10. Scheme for making a multiplexed single-photon source. The control switch in this case monitors which device is active and routes the single photon to the output.

sufficiently large Rabi frequencies that satisfy Eqs. (14) and (19), and performing sufficiently fast atomic state rotations that reset the atomic state to the correct initial state. Similarly, for single-photon detection, the constraint on the number of photons detected per transit event (given approximately by τ/T , where T is the incoming single photon’s duration) comes from the atomic transit time τ , single-photon duration T , and performing sufficiently fast atomic state rotations to reset the atomic state to the correct initial state. We emphasize here that the probability of having a successful heralded single-photon-generation event differs for the abovementioned parametric-down-conversion, quantum-dot, and Rydberg-ensemble platforms. The Rydberg-ensemble and quantum-dot sources are deterministic in the sense that the atomic gas and the quantum dot are always present. However, single-photon generation from spontaneous parametric down-conversion has a small heralded success probability. Such heralded sources can be made near-deterministic using multiplexing [63]. Similarly, we propose using active and passive multiplexing, as discussed in the following section, to make our single-photon sources and single-photon detectors (which both rely on heralding to check if the cavity is active, i.e., if it has an atom in it) near-deterministic.

B. Multiplexing

We now outline how previously discussed protocols for single-photon generation and detection can be multiplexed both actively (i.e., monitoring the cavities and subsequently applying feedback using control switch networks to route single photons) and passively (i.e., without monitoring or feedback).

1. Active multiplexing

For implementing an actively multiplexed single-photon source, several of our single-photon sources (which may be active or not active at any given time) are connected to a control switch as shown in Fig. 10. Detection of an atom in the cavity before the protocol starts ensures that a heralded

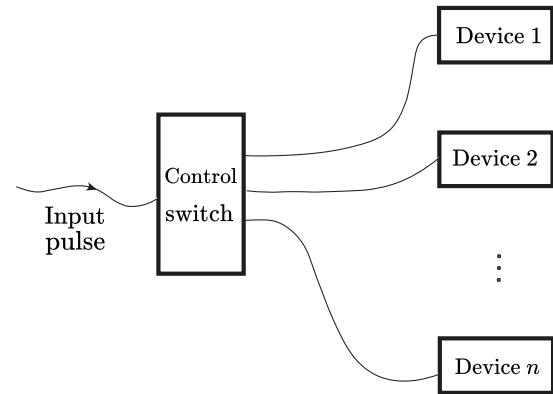

FIG. 11. Scheme for making a multiplexed single-photon detector.

single photon is produced. It is also possible to herald the output photon by measuring the atomic state $|g\rangle$ at the end of the protocol. The switching time should be at least an order of magnitude smaller than the transit time, i.e., at most in the nanosecond range. Similarly, for implementing a multiplexed single-photon detector (as shown in Fig. 11), a control switch routes the input pulse to an active cavity. This scheme works for both the chiral and nonchiral systems. In the nonchiral case (as shown in Fig. 13), active monitoring of the system is necessary to measure the phase ϕ that defines the optical mode $\propto (e^{i\phi}a + e^{-i\phi}b)$.

2. Passive multiplexing

As shown in Fig. 12, we use an array of N cavities to maximize the probability that exactly one of them is active for implementing a passively multiplexed source. For the retrieved single-photon wavefunction to be independent of which cavity is active, we can apply a different control pulse with a suitable time delay to each cavity. We now consider the case where p is the probability that a single cavity is active and assume that this probability is independent of whether other cavities are active or not. Then, maximizing the probability \tilde{p} that exactly one cavity is occupied gives us the optimal number of cavities $\tilde{N} = -1/\ln(1-p) \approx 1/p - 1/2 - p/12 + O(p^2)$ with the corresponding value $\tilde{p} = e^{-1}(1+p/2) + O(p^2)$. However, for $\kappa_i \neq 0$, the single photon experiences photon loss as it passes through the N cavities, leading to an inefficiency contribution that scales, roughly, as $N\kappa_i/\kappa_{\text{ex}}$ [see Eq. (24)]. This scheme works for chiral cavities where the phase measurement of the cavity field is not required.

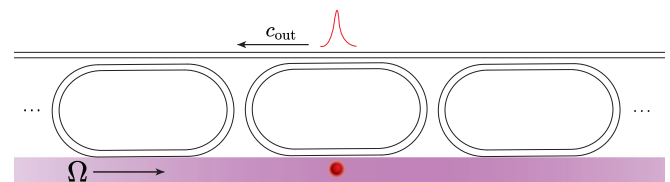

FIG. 12. Passively multiplexed single-photon source in the chiral case. The number of cavities is chosen to maximize the probability of having exactly one active cavity. The position of the atom is not monitored.

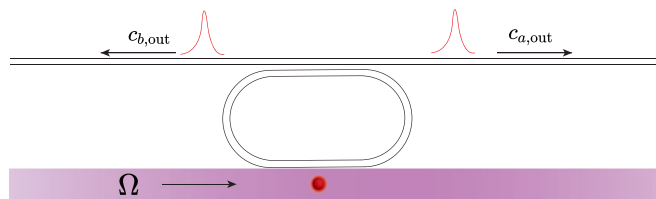

FIG. 13. Single-photon source in the nonchiral case. This requires monitoring the atom's position and the phase of the cavity field defining the optical mode.

C. Experimental considerations

We now consider the experimental conditions necessary to achieve near-ideal single-photon generation and absorption. We consider two nonidealities specific to warm atoms: temporal variation in the coupling g and the Doppler shift of the frequencies of the control pulse and the cavity field. We ignore transit-time broadening because we consider schemes with $T \ll \tau$. We also discuss whether the use of high laser powers to achieve large Rabi frequencies—and the accompanying thermally induced shifts of the cavity resonance due to laser heating—affects the feasibility of our protocols.

We first consider the effect of the variation in time of the coupling strength g . We suppose that, during the time from $t = 0$ to $t = T$, the coupling $g(t)$ varies so little that we can expand $g(t)$ to first order in t as follows: $g(t) = g + \Delta g(t - T/2)/T$. Here, $\Delta g \sim (g/L)(v_{\perp}T)$, where v_{\perp} , the component of the atom's velocity perpendicular to the cavity, is determined by the atomic beam divergence, and the cavity length L is the typical length scale over which g varies. To study the effect of the variation in $g(t)$ on retrieval, we attempt to retrieve into mode $\propto \sin^2(\pi t/T)$ using a control pulse from Eqs. (A4) and (A5) designed assuming that $g(t) = g$. We then compute the infidelity defined as $1 - \langle \psi | \rho | \psi \rangle$, where ρ is the output state and $|\psi\rangle$ is the target state. For absorption, we attempt to absorb the mode $\propto \sin^2(\pi t/T)$ using a time-reversed version of the control pulse from Eqs. (A4) and (A5) designed assuming that $g(t) = g$. We then compute the inefficiency defined as $1 - |c_s(T)|^2$, where $|c_s(T)|^2$ is the probability of the atom being in state s at $t = T$. For case 1 parameters in Table I, numerics show that, for retrieval, the contribution to infidelity due to variation in g , $\mathcal{F}_0 - \mathcal{F}$, where $\mathcal{F}_0(\mathcal{F})$ is the single-photon fidelity for the case $\Delta g = 0$ ($\Delta g \neq 0$), is well approximated by $a_1(\Delta g/g) + a_2(\Delta g/g)^2$ with $|a_1| < |a_2|$. For the example shown in Fig. 14(a), we have $(a_1, a_2) = (0.014, 0.024)$. For case 2, since the resonance about the optimal point x_0 has width Δx [defined in Eq. (16)], the error depends on the relative size of $(\Delta g/g)$ and Δx . In particular, one can use a higher κ_{ex} to broaden the resonance and accommodate a larger error Δg . Numerics show that as long as the condition $|\Delta g/g| < \Delta x$ holds, then for retrieval, the contribution to the infidelity due to Δg is well approximated by $d_1(\Delta g/g) + d_2(\Delta g/g)^2$ with $|d_1| \ll |d_2|$. For the example in Fig. 14(b), $(d_1, d_2) = (-0.0024, 0.22)$. The smaller $\Delta g/g$ is relative to Δx , the smaller the value of d_2 . In cases 1 and 2, inefficiencies due to temporal variation of g for single-photon absorption obey similar error scalings as the corresponding

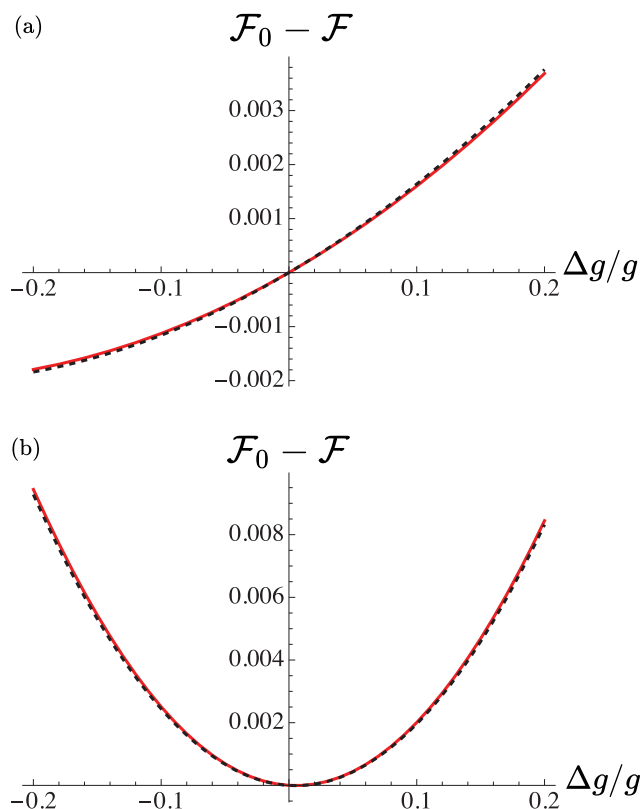

FIG. 14. We plot here the correction to the fidelity of the retrieved photon due to temporal variation in g , as described in Sec. IV C. (a) The red line corresponds to parameters in model cavity 1a (for case 1 in Table I). The correction is described, approximately, by the fit $0.014(\Delta g/g) + 0.024(\Delta g/g)^2$ (shown by the black-dashed line). (b) The red line corresponds to the correction to the fidelity of the retrieved photon for parameters in model cavity 5 (for case 2 in Table II). The corrections are described, approximately, by the fit $-0.0024(\Delta g/g) + 0.22(\Delta g/g)^2$ (shown by the black-dashed line).

inefficiencies for single-photon generation. As an example of experimentally relevant values of $\Delta g/g$, using the parameters of model cavity 2a with an atomic beam divergence of 0.013 rad [30] gives $\Delta g/g \approx 0.01$. This estimate follows from using $g(z) = g_0 e^{-z/\lambda_{\text{ev}}}$ and $z(t) = z_0 + v_{\perp}(t - T/2)$, where z is the distance of the atom from the cavity surface and v_{\perp} is the component of the atom's velocity perpendicular to the cavity surface. Expanding $g(z(t))$ to first order in $v_{\perp}(t - T/2)/\lambda_{\text{ev}}$ gives us $g(t) = g - [gv_{\perp}T/\lambda_{\text{ev}}](t - T/2)/T$, where $g = g_0 e^{-z_0/\lambda_{\text{ev}}}$. Finally, we have $\Delta g/g = v_{\perp}T/\lambda_{\text{ev}}$ with $\lambda_{\text{ev}} \approx 1000$ nm.

We now consider the Doppler shift. Since the proposed atomic levels have different values of e - g and e - s frequencies, the value Δ_{p1} of the Doppler shift to Δ_1 will be different from the value Δ_{p2} of the Doppler shift to Δ_2 . As discussed previously in Sec. IV A, we can use a chiral cavity (with the one relevant optical mode), ensuring that we do not have two optical modes coupled to the same transition with opposite Doppler shifts. As shown in Fig. 9, using the control pulse at an angle to the cavity, we can ensure that both Doppler shifts are equal, i.e., $\Delta_{p1} = \Delta_{p2} = \Delta_d$, where Δ_d denotes

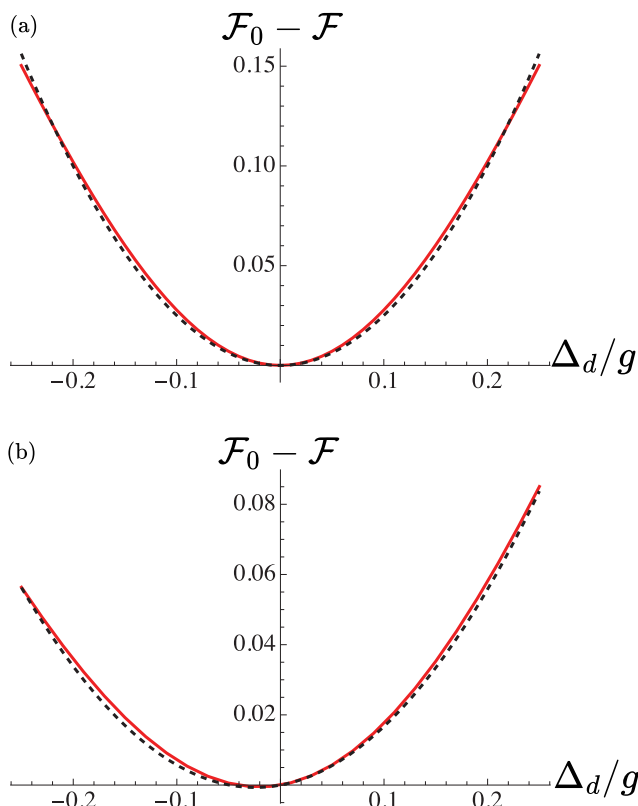

FIG. 15. We plot here the correction to the fidelity of the retrieved photon $\mathcal{F}_0 - \mathcal{F}$ due to Doppler-shifted laser and cavity frequencies. We assume both the control laser and cavity field have the same shift Δ_d (as discussed in Sec. IV C). (a) The red line corresponds to parameters in model cavity 1a in Table I (for case 1). The correction is described, approximately, by the fit $2.5(\Delta_d/g)^2$ (shown by the black-dashed line). (b) The red line corresponds to parameters in model cavity 5 in Table II (for case 2). The correction is described, approximately, by the fit $0.055(\Delta_d/g) + 1.16(\Delta_d/g)^2$ (shown by the black-dashed line).

the common value of both the Doppler shifts. The scheme shown in Fig. 9 works for both lambda and ladder atomic structures, provided one suitably chooses the propagation direction of the control pulse relative to the cavity. Another method is to measure the speed of the atom using classical light and adjust the frequencies of the control pulse and the cavity fields, eliminating both Doppler shifts. The cavity resonance frequency can be varied by changing the temperature of the cavity [64] or using electro-optic modulation [65]. Then, assuming $\Delta_{p1} = \Delta_{p2} = \Delta_d$, we find that, for single-photon retrieval, the contribution to the infidelity for case 1 parameters in Table I scales as $a_2(\Delta_d/g)^2$ for $|\Delta_d/g| < 0.25$. For the example shown in Fig. 15(a), we have $a_2 = 2.5$. For case 2 parameters in Table II, the contribution to the infidelity scales as $d_1(\Delta_d/g) + d_2(\Delta_d/g)^2$ for $|\Delta_d/g| < 0.25$ with $d_1 \ll d_2$. For the example shown in Fig. 15(b), we have $(d_1, d_2) = (0.055, 1.16)$. In cases 1 and 2, Doppler-induced inefficiencies for single-photon absorption obey similar error scalings as the corresponding inefficiencies for single-photon generation. For atoms at room-temperature speeds and the proposed atomic level scheme, $\Delta_d \approx (2\pi)0.38$ GHz, which

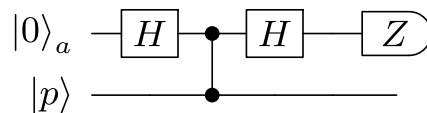

FIG. 16. Protocol for using the atom-photon controlled-phase gate (represented by two black circles connecting the atom and the photon) to implement nondestructive detection of a single photon [67]. If there is no incoming photon ($|p\rangle = |0\rangle$), the atomic state is unchanged. Otherwise, when there is an incoming photon ($|p\rangle = |1\rangle$), the atomic state flips to $|1\rangle_a$.

corresponds to $|\Delta_d/g| \approx 0.24$ for the model cavity parameters considered in Fig. 15.

We note that since the scheme for canceling the Doppler contribution to the two-photon detuning requires the control pulse $\Omega(t)$ to be applied at an angle relative to the cavity, covering the entire trajectory of the atom will require a large beam waist, thereby increasing the required laser power. For the chiral case, using the atomic dipole moment for the s - e transition to estimate the required control pulse power, we find that for beam waists chosen to cover the atom's full trajectory through the cavity, the system parameters in Tables I and II correspond to laser powers below 5 mW. This upper bound on the control pulse power arises because a larger beam waist corresponds to a longer cavity, which in turn corresponds to a smaller single-photon Rabi frequency g and consequently to a smaller classical Rabi frequency $\Omega(t)$, since $\Omega(t) \sim g$ from Eq. (4). We now consider the laser power needed to implement the atomic state measurement scheme described earlier. For the chiral case, we use fast π pulses along the transitions s - $5P_{1/2}$ and $5P_{1/2}$ - g . For example, for all cavities in Tables I and II in the chiral case, laser powers ≈ 1 W can be used to perform the two π pulses within $0.04T$, enabling the heralding process to take time $2.04T$. We now consider the change in cavity resonance frequencies due to laser heating. As discussed in Appendix F, the estimated change in resonance frequencies due to heating is $\approx (2\pi)10$ MHz, which is much smaller than the linewidths of the highly overcoupled cavities [with coupling rates κ_{ex} between $(2\pi)0.9$ GHz and $(2\pi)27$ GHz] considered in this work.

V. ATOM-PHOTON controlled-Z GATE

We now outline the physics of the atom-photon controlled-Z gate. We first consider the simplest case where a single chiral mode a interacts with the atom. This gate has been demonstrated using a trapped atom inside a Fabry-Perot cavity [22,66] and has several uses: cluster state generation (as discussed in Appendix C), quantum communication (as discussed in Appendix D), and, as shown in Fig. 16, nondestructive measurement of photons [67]. Furthermore, as shown in Fig. 17, this gate can be used to implement the photon-photon controlled-Z gate [68].

We have the cavity-atom Hamiltonian in the rotating frame (with the frequency of the input light $\tilde{\omega}_p$) given by

$$H = \Delta_{ap}|e\rangle\langle e| + \Delta_{cp}a^\dagger a + (ga^\dagger|g\rangle\langle e| + \text{H.c.}),$$

$$\Delta_{ap} = \omega_{eg} - \tilde{\omega}_p, \quad x\Delta_{cp} = \omega_c - \tilde{\omega}_p, \quad (21)$$

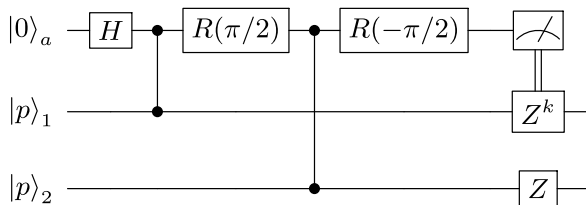

FIG. 17. Protocol for the photon-photon controlled-phase gate [68]. The black circles connecting the atom and a photon represent the atom-photon controlled-phase gate. The unitary $R(\theta)$ is defined by $R(\theta)|0\rangle = \cos(\theta/2)|0\rangle + \sin(\theta/2)|1\rangle$ and $R(\theta)|1\rangle = -\sin(\theta/2)|0\rangle + \cos(\theta/2)|1\rangle$. The correction unitary on the first photon depends on the atom's measurement outcome k in the Z basis. This scheme works for both single-rail photons (encoded in the Fock basis) and dual-rail photons (encoded in the polarization basis). For single-rail photons, $|p\rangle \in \{|0\rangle, |1\rangle\}$, and for dual-rail photons, $|p\rangle \in \{|v\rangle, |h\rangle\}$.

where a is the cavity mode annihilation operator, ω_c is the cavity resonance frequency, $\tilde{\omega}_p$ is the frequency of the incoming pulse, and g is the single-photon Rabi frequency. The following equations [69]

$$\dot{a} = -i[a, H] - \kappa a - \sqrt{2\kappa_{\text{ex}}}a_{\text{in}}, \quad (22)$$

$$a_{\text{out}} = a_{\text{in}} + \sqrt{2\kappa_{\text{ex}}}a \quad (23)$$

can be used to solve for the transmission coefficient [52]. For input photons resonant with the cavity and the atom ($\Delta_{ap} = \Delta_{cp} = 0$), in the limit $\kappa_{\text{ex}}T \rightarrow \infty$, we obtain the following transmission coefficient $t = a_{\text{out}}/a_{\text{in}}$ [for details of the derivation, see Appendix B and Eq. (B9)]:

$$t = \frac{C - 1 + \kappa_i/\kappa_{\text{ex}}}{C + 1 + \kappa_i/\kappa_{\text{ex}}}, \quad (24)$$

where $C = \frac{g^2}{\kappa\gamma}$ is the cooperativity. Here, $|t|$ is always less than 1 due to atomic coherence decay rate γ (when the atom is coupled, i.e., $g \neq 0$) and the cavity's intrinsic loss rate κ_i .

We now consider the case where our input photons (resonant with the bare cavity) have two orthogonal polarizations, h and v , and one of these, say v , does not couple to the cavity [21,68]. Using a third atomic level $|s\rangle$, which does not couple to the cavity, we get a conditional phase gate acting on the atom-photon state, i.e., $\hat{Z}_{ap} = |g\rangle\langle g|_a \otimes I_p + |s\rangle\langle s|_a \otimes (|v\rangle\langle v|_p - |h\rangle\langle h|_p)$. For both $|g\rangle$ and $|s\rangle$ atomic states, v -polarized light (uncoupled from the cavity) passes through the waveguide without interacting with the cavity; therefore, its phase remains unchanged. For the case when the atom is in state $|g\rangle$, the atom-cavity eigenstates are shifted by $\pm g$, enabling h -polarized light (resonant with the bare cavity) in the waveguide to pass through without interacting with the cavity. In the case where the atom is in the state $|s\rangle$, the h -polarized light, now resonant with the cavity, passes through the cavity obtaining a phase shift of π . For single-rail photonic qubits encoded in mode h , we can write the gate as $\hat{Z}_{ap} = |g\rangle\langle g|_a \otimes I_p + |s\rangle\langle s|_a \otimes (|0\rangle\langle 0|_p - |1\rangle\langle 1|_p)$ (Fig. 16 shows how to implement photon detection using this gate). As in the case of single-photon retrieval, this gate can be passively multiplexed (as shown in Fig. 12).

We now consider the nonchiral cavity. In this system, the transmission coefficient calculation gives us the gate \tilde{Z}_{ap} defined as follows:

$$\begin{aligned} \tilde{Z}_{ap} = & |g\rangle\langle g| \otimes (e^{-i2\phi}|R_h\rangle\langle L_h| + e^{i2\phi}|L_h\rangle\langle R_h|) \\ & - |s\rangle\langle s| \otimes (|R_h\rangle\langle R_h| + |L_h\rangle\langle L_h|), \end{aligned} \quad (25)$$

where $|R_h(L_h)\rangle$ denotes a right-moving (left-moving) photon with polarization h that couples to the atom-cavity system. As shown in Appendix B, the controlled-phase gate in the nonchiral case can be implemented using two different schemes. In the first scheme, the phase in $g = |g|e^{i\phi}$ is measured by interferometry using weak classical pulses and the atom-photon interaction from Eq. (25). Using this information, a gate sequence that depends on ϕ can be applied to implement the atom-photon controlled-phase gate (up to an overall minus sign) in the basis $\{|sL_h\rangle, |sR_h\rangle, |gL_h\rangle, |gR_h\rangle\}$ (see Appendix B more details). This version of the protocol can be actively multiplexed (as shown in Fig. 13); i.e., the atom's position in the active cavity and the cavity phase ϕ are monitored. In the second scheme, the phase measurement is not needed. In this scheme, the following gate sequence can be used to implement the controlled-phase gate in the basis $\{|gR\rangle_v, |gR\rangle_h, |sR\rangle_v, |sR\rangle_h\}$:

$$\begin{aligned} \tilde{Z}'_{ap} U_p \tilde{Z}'_{ap} = & |g\rangle\langle g| \otimes (|R\rangle\langle R|_v + |R\rangle\langle R|_h) \\ & + |s\rangle\langle s| \otimes (|R\rangle\langle R|_v - |R\rangle\langle R|_h) \\ & + |g\rangle\langle g| \otimes (|L\rangle\langle L|_v - |L\rangle\langle L|_h) \\ & + |s\rangle\langle s| \otimes (|L\rangle\langle L|_v + |L\rangle\langle L|_h). \end{aligned} \quad (26)$$

Here, the h polarization couples to the atom-cavity system, while the v polarization is uncoupled, \tilde{Z}'_{ap} , defined in Eq. (B28), is the nonchiral-cavity-based atom-photon controlled-phase gate in the basis $\{|R\rangle_v, |R\rangle_h, |L\rangle_v, |L\rangle_h\}$, and $U_p = -|R\rangle\langle R|_h + |L\rangle\langle L|_h + |R\rangle\langle R|_v + |L\rangle\langle L|_v$ (implemented electro-optically using nonreciprocal effects [70]). The main idea is that we can send our photon to the system twice (hence two applications of \tilde{Z}'_{ap}) to get rid of the unwanted phase $e^{i2\phi}$. However, this must be done in a gate sequence that keeps the desired conditional -1 phase intact. The main technical constraint in using this protocol is ensuring that the single-photon duration T is much smaller than the time it takes for the phase of the cavity field to change. This protocol can be passively multiplexed, as shown in Fig. 12, since the phase of the cavity field at the position of the atom does not need to be monitored. For more details, see discussion in Appendix B.

A. Experimental considerations

We now consider how nonidealities in the experiment affect the performance of the controlled-phase gate. For simplicity, we consider the chiral version of the gate. We first consider the effect of finite pulse duration on the fidelity of the output state for the chiral case. In the case $\Delta_{cp} = \Delta_{ap} = 0$ and in the adiabatic limit ($\kappa_{\text{ex}}T \gg 1$), we find the following state fidelities [see Eqs. (B10) for details], where

$F = |\int dt a_{\text{out}} a_{\text{in}}^*|^2$, for the case where the cavity is empty (F_1), and where the cavity has an atom (F_2):

$$\sqrt{F_1} = 1 - \left[\frac{2\kappa_i}{\kappa} + \frac{8\pi^2}{3} \left(1 - \frac{\kappa_i}{\kappa}\right) \left(\frac{1}{\kappa T}\right)^2 \right], \quad (27a)$$

$$\sqrt{F_2} = 1 - \frac{\kappa_{\text{ex}}}{\kappa} \left[C^{-1} + \frac{8\pi^2}{3} \left(\frac{\kappa}{g}\right)^2 \left(\frac{1}{gT}\right)^2 \right]. \quad (27b)$$

Here, the terms proportional to $1/T^2$ are the leading error terms corresponding to the finite duration of the input light. When the cavity is empty, light enters the cavity and suffers photon loss due to the intrinsic loss κ_i . When the atom is coupled to the cavity, light is lost due to decay γ described by the term proportional to C^{-1} . We now briefly comment on the effect of the variation of the coupling strength g in time by an amount Δg (see Sec. IV C for the precise definition of Δg). The lowest-order (in $\Delta g/g$) correction to the state fidelity is third order in ϵ_i , where $\epsilon_1 = \gamma/g$, $\epsilon_2 = \Delta_{cp}/g$, and $\epsilon_3 = \Delta_{ap}/g$. Since $\epsilon_i \ll 1$, the error is negligible. For details, see Appendix B and Eq. (B11).

We now compare the fidelity of our controlled-phase gate with the fidelities of entangling gates in other platforms. The fidelity of the entangled state is defined as $\mathcal{F}_{\text{en}} = \langle \Phi_{ap}^+ | \rho_{ap} | \Phi_{ap}^+ \rangle$, where ρ_{ap} is the output state obtained by applying the controlled-phase gate on the initial state $|+\rangle_a |+\rangle_p$. Here, subscripts a and p denote the atom and photon, respectively. The ideal state is $|\Phi_{ap}^+\rangle \propto |0\rangle_a |+\rangle_p + |1\rangle_a |-\rangle_p$. The values of \mathcal{F}_{en} in Table I compare well with $\mathcal{F}_{\text{en}} = 0.944$ obtained in the state-of-the-art spin-photon system based on a single silicon-vacancy color center integrated inside a diamond nanophotonic cavity [3].

VI. APPLICATIONS

Following work in Refs. [35,36], we can use the coherent emission process, atomic state rotations, and the controlled-phase gate to make protocols for generating cluster states. The protocols are outlined in Appendix C. Moreover, the atom-photon interaction can be used to implement a quantum communication protocol that enables two users to set a shared secret key [3]. Complete protocols for this task using photons encoded in single-rail and dual-rail bases are presented in Appendix D.

ACKNOWLEDGMENTS

We thank Kunal Sharma, Paul Lett, Matthew Hummon, Xiyuan Lu, and Roy Zektzer for helpful discussions. S.A., D.D., and A.V.G. were supported in part by DARPA SAVaNT ADVENT, the DoE ASCR Quantum Testbed Pathfinder program (Awards No. DE-SC0019040 and No. DE-SC0024220), NSF QLCI (Award No. OMA-2120757), NSF STAQ program, AFOSR MURI, ARL (W911NF-24-2-0107), and NQVL:QSTD:Pilot:FTL. S.A., D.D., and A.V.G. also acknowledge support from the U.S. Department of Energy, Office of Science, National Quantum Information Science Research Centers, Quantum Systems Accelerator (QSA), and from the U.S. Department of Energy, Office of Science, Accelerated Research in Quantum Computing,

Fundamental Algorithmic Research toward Quantum Utility (FAR-Qu). K.H., F.Z., and K.S. were supported in part by the DARPA SAVaNT program and the Army Research Office under Cooperative Agreement No. W911NF-21-2-0106. D.D. acknowledges support by the NSF GRFP under Grant No. DGE-1840340 and an LPS Quantum Graduate Fellowship.

DATA AVAILABILITY

The data that support the findings of this article are openly available [71]; embargo periods may apply.

APPENDIX A: DERIVATION OF THE CONTROL PULSE SHAPES FOR SINGLE-PHOTON RETRIEVAL AND ABSORPTION

In this section, we continue our discussion from Sec. IV and provide details on how we compute the control pulse shape $\Omega_0(t)e^{i\phi_0(t)}$ to retrieve/absorb a single-photon pulse with mode shape $h(t)$ and frequency $\omega_c + \Delta_p$ with efficiency η_r . For the chiral case, we can always choose g to be real by redefining mode a . For the nonchiral case, we can absorb the phases into the redefined single mode, $(e^{i\phi}a + e^{-i\phi}b)/\sqrt{2} \rightarrow a$, and then take g in the atom-cavity Hamiltonian to be real. For our convenience, we adjust the phase in the Hamiltonian in Eq. (2) using $|e\rangle \rightarrow i|e\rangle$ to obtain the equations

$$i\dot{c}_s = (\Delta_1 - \Delta_2)c_s - i\Omega^*c_e, \quad (A1)$$

$$i\dot{c}_e = i\Omega c_s - (\Delta_2 + i\gamma)c_e + igc_g, \quad (A2)$$

$$i\dot{c}_g = -igc_e - ikc_g, \quad (A3)$$

where $\Delta_1 = \omega_1 - \omega_{es}$ and $\Delta_2 = \omega_c - \omega_{eg}$. Here, c_s , c_e , and c_g are the amplitudes of states $|s, 0\rangle$, $|e, 0\rangle$, and $a^\dagger|g, 0\rangle$, respectively. Following Ref. [55], we can set $a_{\text{out}} = \sqrt{2\kappa_{\text{ex}}}c_g = \sqrt{\eta_r}h(t)e^{-i\Delta_p t}$, where a_{out} is the output single-photon wavefunction, to solve for the necessary $\Omega_0(t)$ and $\phi_0(t)$ as follows:

$$\Omega_0(t) = \frac{|z|}{\sqrt{\rho_{ss}}}, \quad (A4)$$

$$\phi_0(t) = (\Delta_1 - \Delta_2)t + \arg(z) + i \int_0^t dt' \frac{f(t')}{2\rho_{ss}(t')}, \quad (A5)$$

where

$$z = \dot{c}_e + (\gamma - i\Delta_2)c_e - gc_g, \quad (A6)$$

$$f = zc_e^* - z^*c_e, \quad (A7)$$

$$\dot{\rho}_{ss} = -(zc_e^* + c_e z^*), \quad (A8)$$

where $\rho_{ss} = |c_s|^2$. Note here that f and $\dot{\rho}_{ss}$ are slowly varying functions of time. We note that z , f , and $\dot{\rho}_{ss}$ can be written in terms of $c_g = a_{\text{out}}/\sqrt{2\kappa_{\text{ex}}}$ using Eqs. (A1)–(A3) [c_e can be written in terms of c_g and \dot{c}_g using Eq. (A3)]. We also note that $\arg(z) \approx -\Delta_p t + \text{const}$, which means that setting $\Delta_1 = \Delta_2 + \Delta_p$ ensures that the additional correction to the control pulse's phase is a slowly varying function. In the adiabatic limit ($\kappa_{\text{ex}}T \gg 1$), $\Omega_0(t)$ and ϕ_0 can be computed by writing

z , f , and ρ_{ss} in terms of a_{out} and approximating \dot{h} as zero to obtain

$$\Omega_0(t) = \frac{|\xi_x + i\xi_y|}{g} \frac{A(t)}{\left[1 - (\eta_r/\eta_{\text{max}}) \int_0^t h^2 dt'\right]^{1/2}}, \quad (\text{A9})$$

$$\begin{aligned} \phi_0(t) = & \pi + \arg(\xi_x + i\xi_y) \\ & + \eta_{\text{max}} \frac{(\kappa\xi_y + \Delta_p\xi_x)}{2g^2\kappa_{\text{ex}}} \ln \left(1 - (\eta_r/\eta_{\text{max}}) \int_0^t dt' h^2 \right), \end{aligned} \quad (\text{A10})$$

$$\xi_x = g^2 - \Delta_p^2 - \Delta_2\Delta_p + \kappa\gamma, \quad (\text{A11})$$

$$\xi_y = -\gamma\Delta_p - \kappa(\Delta_p + \Delta_2), \quad (\text{A12})$$

where $A(t) = (\eta_r/2\kappa_{\text{ex}})^{1/2}h(t)$. For single-photon absorption, we use the time-reversed version of the control pulse $\Omega_0(t) \rightarrow -\Omega_0(T-t)$ and $\phi_0(t) \rightarrow -\phi_0(T-t)$ (see discussion in Sec. IV for details).

For an atomic level scheme such that the s state has higher energy than the e state, and the e state has the largest decay rate, we can use the same control pulse as above, except that we redefine Δ_1 to $\omega_{se} - \omega_1$, where ω_{se} is the energy of the s - e transition.

APPENDIX B: OTHER VARIATIONS OF CAVITIES AND THEIR PHASE SHIFT CALCULATION

In this section, we present the details of the phase shift calculation (presented in Sec. V) for both chiral and nonchiral microcavities. We follow Ref. [52].

1. Case 1: chiral setup

We compute here the transmission coefficient in the chiral mode case discussed in Sec. V. We excite the a mode by sending in light through mode a_{in} . The cavity-atom Hamiltonian in the rotating frame is

$$\begin{aligned} H = & \Delta_{ap}|e\rangle\langle e| + \Delta_{cp}(a^\dagger a + b^\dagger b) + h(a^\dagger b + b^\dagger a) \\ & + (ga^\dagger|g\rangle\langle e| + ga|e\rangle\langle g|), \end{aligned} \quad (\text{B1})$$

$$\Delta_{ap} = \omega_{eg} - \tilde{\omega}_p, \quad (\text{B2})$$

$$\Delta_{cp} = \omega_c - \tilde{\omega}_p, \quad (\text{B3})$$

where $\tilde{\omega}_p$ is the frequency of the incoming photon pulse and h is the coupling between the two modes due to backscattering. The equations of motion are

$$\begin{aligned} \dot{c}_{g,a} = & -(\kappa + i\Delta_{cp})c_{g,a} - ihc_{g,b} - igc_e \\ & - \sqrt{2\kappa_{\text{ex}}}a_{\text{in}}(t), \end{aligned} \quad (\text{B4})$$

$$\dot{c}_{g,b} = -(\kappa + i\Delta_{cp})c_{g,b} - ihc_{g,a}, \quad (\text{B5})$$

$$\dot{c}_e = -(\gamma + i\Delta_{ap})c_e - igc_{g,a}, \quad (\text{B6})$$

where $c_{g,a}$, $c_{g,b}$, and c_e are the amplitudes of states $a^\dagger|g, 0\rangle$, $b^\dagger|g, 0\rangle$, and $|e, 0\rangle$, respectively, and $c_{a(b),\text{in}}$ is the

single-photon input to mode $a(b)$ (as shown in Fig. 3). We can then use the Fourier transform

$$\tilde{A}(\omega) = \frac{1}{\sqrt{2\pi}} \int dt e^{i\omega t} A(t), \quad (\text{B7})$$

$$A(t) = \frac{1}{\sqrt{2\pi}} \int d\omega e^{-i\omega t} \tilde{A}(\omega) \quad (\text{B8})$$

to obtain a set of linear equations. For $h = 0$, we have the following transmission coefficient t :

$$t = \frac{a_{\text{out}}}{a_{\text{in}}} = \frac{\kappa_i + i\Delta_{cp} + \frac{g^2}{i\Delta_{ap} + \gamma} - \kappa_{\text{ex}}}{\kappa_i + i\Delta_{cp} + \frac{g^2}{i\Delta_{ap} + \gamma} + \kappa_{\text{ex}}}. \quad (\text{B9})$$

On resonance (i.e., when $\Delta_{cp} = \Delta_{ap} = 0$), we get Eq. (24), where $C = \frac{g^2}{\kappa\gamma}$. The leading error terms in the state fidelity $F = |\int dt a_{\text{out}} a_{\text{in}}^*|^2$ can be computed from solving Eqs. (B4)–(B6) in the adiabatic limit ($\kappa_{\text{ex}}T \gg 1$). For $\Delta_{cp} = \Delta_{ap} = 0$ and $h = 0$, we have

$$1 - \sqrt{F_1} = \frac{2\kappa_i}{\kappa} + \frac{8\pi^2}{3} \left(1 - \frac{\kappa_i}{\kappa}\right) \left(\frac{1}{\kappa T}\right)^2, \quad (\text{B10a})$$

$$1 - \sqrt{F_2} = \frac{\kappa_{\text{ex}}}{\kappa} \left[C^{-1} + \frac{8\pi^2}{3} \left(\frac{\kappa}{g}\right)^2 \left(\frac{1}{gT}\right)^2 \right], \quad (\text{B10b})$$

where $F_1(F_2)$ is the state fidelity wherein the atom is uncoupled from (coupled to) the cavity. We use $a_{\text{in}} \propto \sin^2(\pi t/T)$.

We now consider the case where $g(t) = g_0 - \Delta g f(t)$, where f is a slowly varying function that goes from 0 to 1. The amplitude c_g can be solved using the ansatz $c_g = \sum_{n=0} c_{gn} \beta^n$, where $\beta = \Delta g/g_0$, giving the equation

$$\ddot{c}_{gn} = -\alpha c_{gn} - \sigma \dot{c}_{gn} + W_n, \quad (\text{B11})$$

where

$$\alpha = g_0^2 + (\gamma + i\Delta_{ap})(\kappa + i\Delta_{cp}), \quad (\text{B12})$$

$$\sigma = (\kappa + \gamma) + i(\Delta_{ap} + \Delta_{cp}), \quad (\text{B13})$$

$$W_0 = -\sqrt{2\kappa_{\text{ex}}}(\gamma + i\Delta_{ap})a_{\text{in}} - \sqrt{2\kappa_{\text{ex}}}\dot{c}_{\text{in}}, \quad (\text{B14})$$

$$\begin{aligned} W_1 = & -\sqrt{2\kappa_{\text{ex}}}a_{\text{in}}\dot{f} - \dot{c}_{g0}\dot{f} \\ & + c_{g0}[2g_0^2\dot{f} - \dot{f}(\kappa + i\Delta_{cp})]. \end{aligned} \quad (\text{B15})$$

We note here that c_{g1} is coupled to c_{g0} via W_1 . The equations can be solved using Fourier transformation. The lowest-order (in $\Delta g/g_0$) correction to the state fidelity is third order in ϵ_i , where $\epsilon_1 = \gamma/g_0$, $\epsilon_2 = \Delta_{cp}/g_0$, and $\epsilon_3 = \Delta_{ap}/g_0$. Since $\epsilon_i \ll 1$, the error is negligible.

2. Case 2: nonchiral setup

Here, we study the atom-photon controlled-phase gate for the nonchiral case, wherein both modes a and b couple to the atom-cavity system. The atom-cavity Hamiltonian in the rotating frame is

$$\begin{aligned} H = & \Delta_{ap}|e\rangle\langle e| + \Delta_{cp}(a^\dagger a + b^\dagger b) + h(a^\dagger b + b^\dagger a) \\ & + g(e^{-i\phi}a^\dagger|g\rangle\langle e| + e^{i\phi}a|e\rangle\langle g|) \\ & + g(e^{i\phi}b^\dagger|g\rangle\langle e| + e^{-i\phi}b|e\rangle\langle g|), \end{aligned} \quad (\text{B16})$$

$$\Delta_{ap} = \omega_{eg} - \tilde{\omega}_p, \quad (\text{B17})$$

$$\Delta_{cp} = \omega_c - \tilde{\omega}_p. \quad (\text{B18})$$

We note here that the above Hamiltonian can be mapped to the Hamiltonian from the chiral case in Eq. (B1) by mapping $(e^{i\phi}a + e^{i\phi}b)/\sqrt{2} \rightarrow a$ and $g\sqrt{2} \rightarrow g$ [and mapping $(e^{i\phi}a_{\text{in}} + e^{i\phi}b_{\text{in}})/\sqrt{2} \rightarrow a_{\text{in}}$ and $(e^{i\phi}a_{\text{out}} + e^{i\phi}b_{\text{out}})/\sqrt{2} \rightarrow a_{\text{out}}$ accordingly]. However, in contrast to the chiral case in which we drive the mode that couples to the atom, here we choose to separately drive modes a and b that only partially couple to the mode $(e^{i\phi}a + e^{i\phi}b)/\sqrt{2}$. The equations of motion can then be written as

$$\dot{c}_{g,a} = -(\kappa + i\Delta_{cp})c_{g,a} - ihc_{g,b} - ig e^{-i\phi}c_e - \sqrt{2\kappa_{\text{ex}}}a_{\text{in}}(t), \quad (\text{B19})$$

$$\dot{c}_{g,b} = -(\kappa + i\Delta_{cp})c_{g,b} - ihc_{g,a} - ig e^{i\phi}c_e - \sqrt{2\kappa_{\text{ex}}}b_{\text{in}}(t), \quad (\text{B20})$$

$$\dot{c}_e = -(\gamma + i\Delta_{ap})c_e - ig e^{i\phi}c_{g,a} - ig e^{-i\phi}c_{g,b}, \quad (\text{B21})$$

where $c_{g,a}$, $c_{g,b}$, and c_e are the amplitudes in the states $a^\dagger|g, 0\rangle$, $b^\dagger|g, 0\rangle$, and $|e, 0\rangle$, respectively, and $a_{\text{in}}(b_{\text{in}})$ is the single-photon input to the mode $a(b)$ (see Fig. 3). Then, for $\Delta_{ap} = \Delta_{cp} = 0$, $\kappa_1 \ll \kappa_{\text{ex}}$, and $h = 0$, we have

$$c_{g,a} = -\frac{\sqrt{2\kappa_{\text{ex}}}}{\kappa} \left[\frac{(1+C)a_{\text{in}} - C e^{-i2\phi}b_{\text{in}}}{1+2C} \right], \quad (\text{B22})$$

$$c_{g,b} = -\frac{\sqrt{2\kappa_{\text{ex}}}}{\kappa} \left[\frac{(1+C)b_{\text{in}} - C e^{i2\phi}a_{\text{in}}}{1+2C} \right], \quad (\text{B23})$$

where ϕ is defined in Eq. (B16) and $C = g^2/\kappa\gamma$. We expect nonzero values of h that satisfy $h \ll \kappa_{\text{ex}}$ to reduce the fidelity of the states only marginally. When the atom is not coupled to the cavity ($g = 0$) and $\kappa_1 \ll \kappa_{\text{ex}}$, we have

$$a_{\text{out}} = -a_{\text{in}}, \quad (\text{B24a})$$

$$b_{\text{out}} = -b_{\text{in}}. \quad (\text{B24b})$$

For strong atom-cavity coupling ($C \gg 1$) and $\kappa_1 \ll \kappa_{\text{ex}}$, we get

$$a_{\text{out}} = e^{-i2\phi}b_{\text{in}}, \quad (\text{B25a})$$

$$b_{\text{out}} = e^{i2\phi}a_{\text{in}}. \quad (\text{B25b})$$

We can then write this process as the unitary

$$\tilde{Z}_{ap} = |g\rangle\langle g| \otimes (e^{-i2\phi}|R\rangle\langle L| + e^{i2\phi}|L\rangle\langle R|) - |s\rangle\langle s| \otimes (|R\rangle\langle R| + |L\rangle\langle L|), \quad (\text{B26})$$

where $|R(L)\rangle$ corresponds to the right-moving (left-moving) single photon leaking to the waveguide through the cavity mode $a(b)$ (see also Fig. 3).

Now, this gate can be used to implement the atom-photon controlled-phase gate within the photon basis $\{|R\rangle, |L\rangle\}$ by using the sequence $H_p V \tilde{Z}_{ap} V^\dagger H_p$, where $V = e^{-i2\phi}|L\rangle\langle L| + |R\rangle\langle R|$ (implemented using electro-optics), and H_p is the Hadamard gate in the $\{|R, L\rangle$ basis. This assumes we can

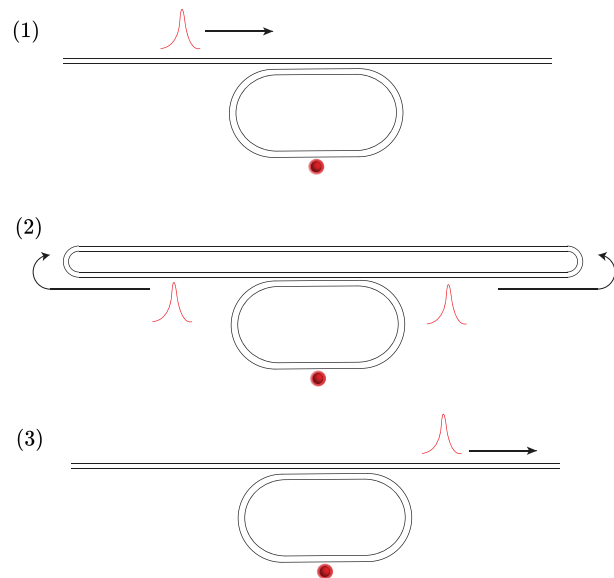

FIG. 18. In this figure, we show the steps used to implement the atom-photon controlled-phase gate for the nonchiral cavity without monitoring the atom.

measure the phase ϕ quickly enough. We then get the gate

$$H_p V \tilde{Z}_{ap} V^\dagger H_p = |g\rangle\langle g| \otimes (|R\rangle\langle R| - |L\rangle\langle L|) - |s\rangle\langle s| \otimes (|R\rangle\langle R| + |L\rangle\langle L|), \quad (\text{B27})$$

which is the controlled-phase gate in the basis $\{|sL\rangle, |sR\rangle, |gL\rangle, |gR\rangle\}$ (up to an overall minus sign).

We now consider another gate sequence to implement the atom-photon controlled-phase gate without measuring the phase ϕ . We consider single photons with polarizations h and v ; h couples to the atom-cavity system, and v does not. In the larger photon basis $\{|R\rangle_v, |R\rangle_h, |L\rangle_v, |L\rangle_h\}$, where $|R(L)\rangle_x$ denotes the right-moving (left-moving) photon with polarization x , consider the gate sequence $\tilde{Z}'_{ap} U_p \tilde{Z}'_{ap}$, where $U_p = -|R\rangle\langle R|_h + |L\rangle\langle L|_h + |R\rangle\langle R|_v + |L\rangle\langle L|_v$, and

$$\tilde{Z}'_{ap} = |g\rangle\langle g| \otimes (e^{-i2\phi}|R\rangle\langle L|_h + e^{i2\phi}|L\rangle\langle R|_h + |R\rangle\langle R|_v + |L\rangle\langle L|_v) + |s\rangle\langle s| \otimes (-|R\rangle\langle R|_h - |L\rangle\langle L|_h + |R\rangle\langle R|_v + |L\rangle\langle L|_v). \quad (\text{B28})$$

We then have

$$\tilde{Z}'_{ap} U_p \tilde{Z}'_{ap} = |g\rangle\langle g| \otimes (|R\rangle\langle R|_v + |R\rangle\langle R|_h) + |s\rangle\langle s| \otimes (|R\rangle\langle R|_v - |R\rangle\langle R|_h) + |g\rangle\langle g| \otimes (|L\rangle\langle L|_v - |L\rangle\langle L|_h) + |s\rangle\langle s| \otimes (|L\rangle\langle L|_v + |L\rangle\langle L|_h). \quad (\text{B29})$$

This gate acting on the atom-photon basis states $\{|gR\rangle_v, |gR\rangle_h, |sR\rangle_v, |sR\rangle_h\}$ gives us the atom-photon controlled-phase gate. In Fig. 18, we show the steps used to implement the atom-photon controlled-phase gate. Consider the initial state $|\psi\rangle = c_{gR_v}|gR_v\rangle + c_{gR_h}|gR_h\rangle + c_{sR_v}|sR_v\rangle + c_{sR_h}|sR_h\rangle$. In step 1, we send the photon to the cavity to obtain

the state

$$\begin{aligned} \tilde{Z}'_{ap}|\psi\rangle &= c_{gR_v}|gR_v\rangle + e^{i2\phi}c_{gR_h}|gR_h\rangle \\ &+ c_{sR_v}|sR_v\rangle - c_{sR_h}|sR_h\rangle. \end{aligned} \quad (\text{B30})$$

In step 2, we apply the gate U_p , realized electro-optically using nonreciprocal effects [70], to obtain the state

$$\begin{aligned} U_p\tilde{Z}'_{ap}|\psi\rangle &= c_{gR_v}|gR_v\rangle + e^{i2\phi}c_{gR_h}|gR_h\rangle \\ &+ c_{sR_v}|sR_v\rangle + c_{sR_h}|sR_h\rangle. \end{aligned} \quad (\text{B31})$$

Both the right-moving and left-moving parts of the photon are routed back to the cavity as shown in Fig. 18. This step can be implemented using electro-optics. This reapplies the gate \tilde{Z}'_{ap} in step 3 to obtain the state

$$\begin{aligned} \tilde{Z}'_{ap}U_p\tilde{Z}'_{ap}|\psi\rangle &= c_{gR_v}|gR_v\rangle + c_{gR_h}|gR_h\rangle \\ &+ c_{sR_v}|sR_v\rangle - c_{sR_h}|sR_h\rangle, \end{aligned} \quad (\text{B32})$$

implementing the atom-photon controlled-phase gate. Moreover, instead of using h and v polarizations, we can use different waveguides for dual-rail encoded photons such that one waveguide couples to the atom-cavity system and one does not.

APPENDIX C: CLUSTER STATES

In this section, we present the details of the protocols developed in Refs. [35,72] to generate cluster states using the primitives (i.e., single-photon retrieval/absorption and the atom-photon controlled-phase gate) studied in this work. We first consider single-rail-encoded cluster states. We relabel the atomic states considered before as $|0\rangle_a = |g\rangle$ and $|1\rangle_a = |s\rangle$. The pulse sequence for retrieval can then be represented by the operator $P_{a,i} = |0\rangle\langle 0|_a \otimes I_i + |0\rangle\langle 1|_a \otimes |1\rangle\langle 0|_i$, where i labels the photon state's time bin, and the operator is understood to act only on atom-photon states with the photonic state in the cavity being in the vacuum. We note here that, since the atom moves across the cavity and the relative phase between the coupling g and the control laser $\Omega(t)$ changes, the state $|0\rangle_a(|0\rangle_i + e^{i\psi}|1\rangle_i)$ will have a phase ψ dependent on the position of the atom. We can ensure that the atom-photon states have a phase that is independent of the atom position for the chiral case by matching the wave vectors of the cavity and laser fields (similar to how we cancel the Doppler contribution to the two-photon detuning for the lambda system in Fig. 9).

For example, consider the protocol for making a Greenberger-Horne-Zeilinger (GHZ) state. Starting with the state $(|0\rangle_a + |1\rangle_a)|0\rangle_1$, applying the control pulse, $P_{a,1}$, gives the state $|0\rangle_a(|0\rangle_1 + |1\rangle_1)$. Applying the Hadamard gate to the atomic state (denoted by H_a), followed by atom-photon controlled-phase gate $\hat{Z}_{a,1}$, and then reapplied H_a to the atom gives the entangled state $|00\rangle_{a1} + |11\rangle_{a1}$. To pass this entanglement to the photon states 1 and 2, we apply $P_{a,2}$ to get the state $|0\rangle_a \otimes (|00\rangle_{12} + |11\rangle_{12})$. Extending this protocol as in Fig. 19(a) produces the n -photon GHZ state. Measuring the $|0\rangle_a$ state after the last $P_{a,i}$ confirms that the atom has not escaped the cavity during the gate sequence. In summary, for each additional photon in the state, we need to send the photon in the preceding time bin to the cavity for an atom-photon controlled-phase gate (with Hadamard gates on the

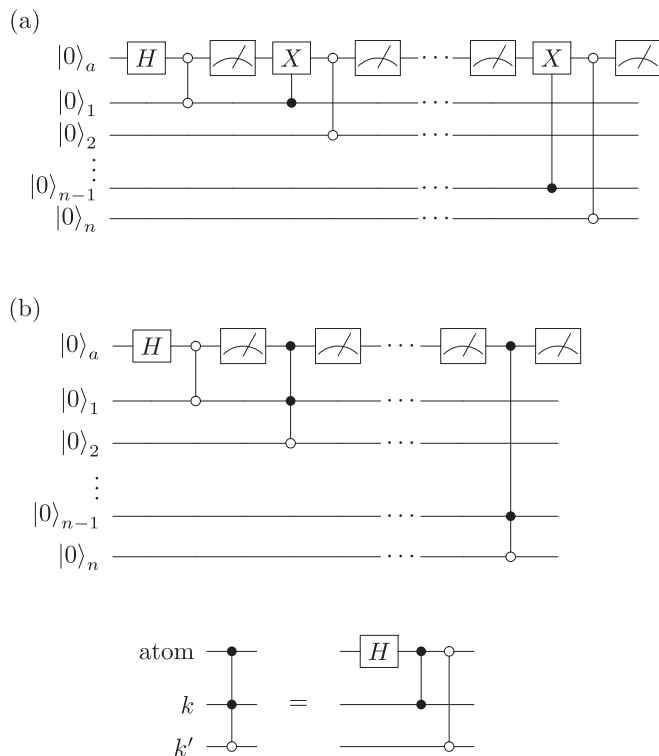

FIG. 19. Protocols for making (a) a GHZ state and (b) a 1D cluster state in the single-rail encoding. The two white circles that connect the atom and the state of photon k represent the gate $P_{a,k}$ implemented by the control pulse. Here, the two filled circles connected by a line denote the atom-photon controlled-phase gate. The atom-photon controlled X gate is implemented by sandwiching the controlled-phase gate with the Hadamard gates on the atom.

atom before and after the interaction), and a control pulse to implement $P_{a,i}$.

We now discuss the protocol to create cluster states defined in Ref. [41]. The key identity used here is

$$\begin{aligned} P_{a,n+1}\hat{Z}_{aj}H_a|0\rangle_a|\phi\rangle|0\rangle_{n+1} &= |0\rangle_a\hat{Z}_{n+1,j}|\phi\rangle|+\rangle_{n+1}, \\ \hat{Z}_{aj} &= \prod_{i=1}^{n'}\hat{Z}_{aj_i}, \quad i \in \{1, \dots, n'\}, \end{aligned} \quad (\text{C1})$$

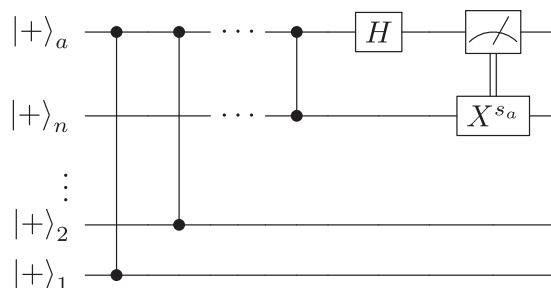

FIG. 20. Circuit for making the state $H^{\otimes n}|\psi\rangle$ in the polarization basis (i.e., dual-rail encoding), where $|\psi\rangle$ is the n -photon GHZ state. Here, s_a is the atomic state measurement outcome in the Z basis, and the unitary after the measurement can be applied to any photon.

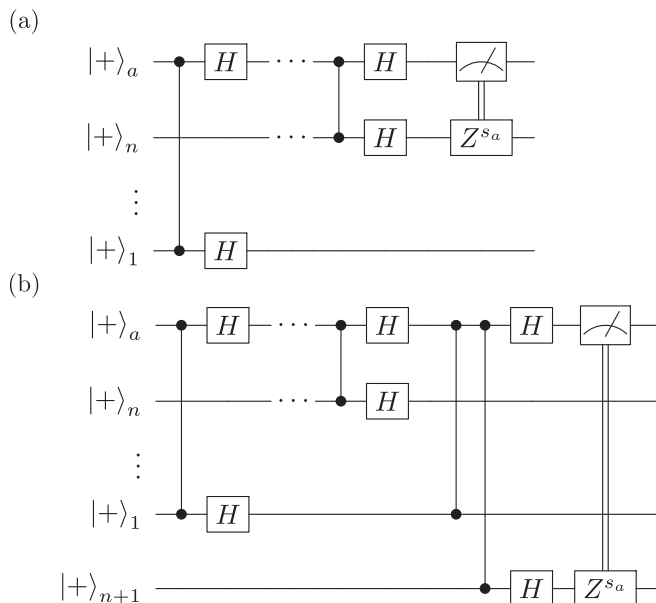

FIG. 21. Circuits for making 1D cluster states in the polarization basis (i.e., dual-rail encoding). Here, a labels the atomic state, and the states with numbers as subscripts correspond to photons. (a) Circuit for making 1D linear cluster states. Before measurement of the atomic state, the system's state is a 1D cluster state with the atom at one end. Measuring the atom in the Z basis with outcome s_a disconnects the atom. (b) Circuit for making the $(n+1)$ -qubit resource state as defined by a ring graph [73].

where \hat{Z}_{aj} is a controlled-phase gate between the atom and photons indexed in j , \hat{Z}_{nj} is a controlled-phase gate between the photon labeled n and photons indexed in j , $|\phi\rangle$ is an arbitrary n -photon state, and j_i (with $i \leq n'$) indexes some photon states in $|\phi\rangle$. The net effect of this step is to implement the gate \hat{Z}_{n+1j} on the $(n+1)$ -photon state $|\phi\rangle|+\rangle_{n+1}$. If the state $|\phi\rangle$ is a cluster state, it follows that the state after the control sequence is also one. For example, consider the initial state $|0\rangle_a|+\rangle_1|0\rangle_2$. Applying the sequence $P_{a,2}Z_{a1}H_a$ gives the state $|0\rangle_a\hat{Z}_{21}|+\rangle_{12}$. This can be extended to make the n -photon 1D cluster state [see Fig. 19(b)], as well as cluster states in two and three dimensions using time delays [36,72].

Similarly, work in Refs. [35,72] shows that the atom-photon controlled-phase gate can be combined with atomic state rotations to create cluster states in the polarization basis. As examples, we show protocols to create GHZ states and 1D

TABLE III. Truth table for the case where Alice and Bob use x -basis inputs. Here, m_i are the Z -basis measurement results obtained by Charlie.

m_1	m_2	$\phi_1 + \phi_2$
1	1	0
1	-1	π
-1	1	0
-1	-1	π

TABLE IV. Truth table for the case where Alice and Bob use y -basis inputs. Here, m_i are the Z -basis measurement results obtained by Charlie.

m_1	m_2	$\phi_1 + \phi_2$
1	1	0
1	-1	π
-1	1	π
-1	-1	0

cluster states in Figs. 20 and 21, respectively. The generalization to higher dimensions is possible using time delays [72].

APPENDIX D: QUANTUM COMMUNICATION

In this section, we explain how the basic primitives studied in our work (i.e., single-photon retrieval/absorption and the atom-photon controlled-phase gate) can be used to implement a quantum communication protocol that enables two users to set a shared secret key [3]. Here, Alice and Bob wish to establish a shared secret random bit string using a central node, Charlie. Alice and Bob randomly choose the basis (X or Y) and the state of their photonic qubits that they send to Charlie. This information is encoded in the photonic state through phase ϕ : $|0\rangle + e^{i\phi}|1\rangle$. The $X(Y)$ basis choice means that the state will have $\phi = \{\pi, -\pi\}(\{\pi/2, -\pi/2\})$. Charlie, who has access to an atom coupled to a cavity, will perform gates and measurements on both his atomic states and the photonic states he receives from Alice and Bob. We outline two versions of the protocol for the two possible bases: Fock states (single-rail encoding) and polarization states (dual-rail encoding), respectively. At the end of the protocol, Alice and Bob broadcast their bases, and Charlie broadcasts the Z -basis measurement results m_i . Instances where Alice and Bob had used different bases are discarded. Knowledge of the outcomes will allow Alice and Bob to ascertain whether their states were the same or different since the measurement outcomes, m_i , are distinguishable for the two cases $\phi_1 + \phi_2 = \{0, \pi\}$ for any basis choice, where ϕ_1 and ϕ_2 define Alice's and Charlie's photonic states, respectively. They can then set their shared secret key; for example, Bob can flip his bit values that disagree with Alice at the end of the protocol so that both have a secret correlated bit string. Crucially, the measurement

TABLE V. Truth table for x -basis inputs. Here, m_i are the Z -basis measurement results obtained by Charlie.

m_1	m_2	m_3	$\phi_1 + \phi_2$
1	1	1	0
1	-1	1	0
-1	1	-1	0
-1	-1	-1	0
1	1	-1	π
1	-1	-1	π
-1	1	1	π
-1	-1	1	π

TABLE VI. Truth table for y -basis inputs. Here, m_i are the Z -basis measurement results obtained by Charlie.

m_1	m_2	m_3	$\phi_1 + \phi_2$
1	1	1	0
1	-1	-1	0
-1	1	-1	0
-1	-1	1	0
1	1	-1	π
1	-1	1	π
-1	1	1	π
-1	-1	-1	π

outcomes and the basis choice can only reveal the sum of the phases.

1. Fock-basis encoding

We now outline the communication protocol for Fock-basis photons. This protocol uses control pulses (for single-photon storage), atomic state rotations, and the atom-photon controlled-phase gate. Alice sends her qubit $|0\rangle_1 + e^{i\phi_1}|1\rangle_1$ to Charlie, whose atom is in state $|0\rangle_a$. Charlie applies the control laser to store the single photon so that his atomic state becomes $|0\rangle_a + e^{i\phi_1}|1\rangle_a$. Bob then sends his photon in state $|0\rangle_2 + e^{i\phi_2}|1\rangle_2$ to Charlie, and Charlie applies the sequence $H_a \hat{Z}_{a2} H_a$ to obtain the state $|0\rangle_a(|0\rangle_2 + e^{i\phi_1+i\phi_2}|1\rangle_2) + |1\rangle_a(e^{i\phi_1}|0\rangle_2 + e^{i\phi_2}|1\rangle_2)$. Charlie then measures the atomic state in the Z basis to obtain outcome m_1 . If he measures $m_1 = 1$, he does nothing, and if he measures $m_1 = -1$, he applies the gate X_a to the atomic state, obtaining the state $|0\rangle_a(|0\rangle_2 + e^{i\phi_2+im_1\phi_1}|1\rangle_2)$. The next step is to store the photonic state 2 to obtain the atomic state $|0\rangle_a + e^{i\phi_2+im_1\phi_1}|1\rangle_a$. Finally, Charlie applies the gate H_a to his atom, measures the atom in the Z basis to obtain m_2 , and then broadcasts m_1 and m_2 . See Tables III and IV for the truth table that connects the outcomes m_1 and m_2 with $\phi_1 + \phi_2$.

2. Polarization-basis encoding

We now outline the communication protocol for photons encoded in the polarization basis. We use the definitions $|0\rangle = |v\rangle$ and $|1\rangle = |h\rangle$, where h couples to the atom-cavity system while v remains uncoupled. In the first step, Alice sends her photon in state $|0\rangle_1 + e^{i\phi_1}|1\rangle_1$ to Charlie who has his atomic qubit in state $|0\rangle_a + |1\rangle_a$. After Charlie performs the atom-photon controlled-phase gate, the atom-photon state is

$|0\rangle_a(|0\rangle_1 + e^{i\phi_1}|1\rangle_1) + |1\rangle_a(|0\rangle_1 - e^{i\phi_1}|1\rangle_1)$. After performing the Hadamard gate on both the atom and the photon, Charlie measures the photon state in the Z basis with outcome m_1 , which results in the atomic state $|0\rangle_a + m_1 e^{i\phi_1}|1\rangle_a$. We remark here that this state can also be obtained by storing the single-photon state $|0\rangle_2 + e^{i\phi_1}|1\rangle_2$. In the second step, Bob sends his photonic qubit in state $|0\rangle_2 + e^{i\phi_2}|1\rangle_2$ to Charlie. Charlie performs a Hadamard gate on the photon, a controlled-phase gate on the atom-photon state, and then another Hadamard gate on the photon state. This gives the atom-photon state $(|0\rangle_a + m_1 e^{i(\phi_1+\phi_2)}|1\rangle_a)|0\rangle_2 + (e^{i\phi_2}|0\rangle_a + m_1 e^{i\phi_1}|1\rangle_a)|1\rangle_2$. After measuring the photonic state in the Z basis with outcome m_2 , the atomic state is $|0\rangle_a + m_1 e^{i(\phi_1+m_2\phi_2)}|1\rangle_a$. After performing a Hadamard gate on the atom, Charlie measures the atomic state in the Z basis to get measurement outcome m_3 . Since $\phi_1 + \phi_2 = \{0, \pi\}$, m_3 will have a value fixed by previous measurement outcomes. As before, the measurement outcomes depend only on the sum of the phases, $\phi_1 + \phi_2$, allowing Alice and Bob to set a correlated key. See Tables V and VI for the truth table that connects the outcomes with $\phi_1 + \phi_2$.

APPENDIX E: FROM ROOM-TEMPERATURE ATOMS TO ULTRACOLD ATOMS

In this section, we consider how various cooling methods can allow for a higher number of operations per transit event. There are several methods for slowing down atoms from the 300 m/s velocity we assume in the main text, with the resulting transit time inversely proportional to the velocity. We list a few examples in Table VII, comparing the figures of merit to those obtained from using model cavity 1a in Table I (using room-temperature atoms). We note that increased cooling generally comes with larger infrastructure requirements. The first method is Zeeman cooling, which reduces the speed of Rb atoms to 12 m/s [74], resulting in $\tau = 343$ ns for cavity 1a. The second method uses atoms released from a magneto-optical trap (MOT) which corresponds to $\tau = 1.5 \mu\text{s}$ [20]. The last method uses a dipole trap that corresponds to $\tau = 2$ ms [75]. Table VII shows the number of operations per transit time τ/T achievable through larger values of τ using various cooling techniques.

APPENDIX F: ESTIMATING THE EFFECT OF STRONG LASERS ON CAVITY RESONANCES

We estimate the change in temperature due to power absorbed by the cavity for silicon nitride resonators. The change

TABLE VII. Examples of key metrics for case 1 with different methods of cooling the atoms. Here, g is the single-photon Rabi frequency, κ is the waveguide coupling rate, κ_i is the microcavity's intrinsic loss, 2γ is the decay rate of state e , and $C = g^2/\kappa\gamma$ is the cooperativity. $\kappa = \kappa_{\text{ex}} + \kappa_i$, T is the single-photon duration, and τ is the atomic transit time. Frequencies and times are in (2π) GHz and ns. \mathcal{F} is the single-photon fidelity, \mathcal{F}_{en} is the entangling fidelity, η_{abs} is the probability of measuring state s after photon absorption, and η_d is the probability of correct detection via a controlled-phase gate. The cavity parameters correspond to silicon nitride microdisk optical resonators [57].

Cooling method	g	κ_{ex}	κ_i	2γ	C	$2\Omega_0$	$1 - \mathcal{F}$	$1 - \mathcal{F}_{\text{en}}$	$1 - \eta_{\text{abs}}$	$1 - \eta_d$	T	τ	τ/T
Zeeman cooling	1.6	2	0.01	0.0061	420	0.7	0.0098	0.014	0.0098	0.019	7.96	343	43
MOT	1.6	2	0.01	0.0061	420	0.5	0.0098	0.011	0.0098	0.019	15.9	1500	94
Dipole trap	1.6	2	0.01	0.0061	420	0.5	0.0098	0.011	0.0098	0.019	15.9	2×10^6	1.3×10^5

in frequency of the cavity $\Delta\nu$ can be computed as follows:

$$\Delta\nu = -\nu \left(\frac{1}{n_{\text{eff}}} \frac{dn_{\text{eff}}}{dT} + \alpha_L \right) \Delta T, \quad (\text{F1})$$

where $\nu \approx (2\pi)384.1$ THz (corresponding to 780 nm) is the cold cavity frequency for our system, $\alpha_L \approx 3 \times 10^{-6} \text{ K}^{-1}$ is the characteristic thermal expansion coefficient [76], and $\frac{1}{n_{\text{eff}}} \frac{dn_{\text{eff}}}{dT} \approx 1 \times 10^{-5} \text{ K}^{-1}$, where $\frac{dn_{\text{eff}}}{dT}$ is the thermo-optic coefficient [76]. We can compute ΔT using

$$\Delta T = R_{\text{th}} P_{\text{abs}}, \quad (\text{F2})$$

where $R_{\text{th}} \approx 333 \text{ K/W}$ is the characteristic thermal resistance for silicon nitride resonators [77]. For laser powers of 1 W, corresponding to the largest Rabi frequencies considered in our protocols and system parameters, and using beam waists approximately equal to the cavity length (chosen to cover the atomic trajectories), the laser power absorbed by the resonator is $P_{\text{abs}} = (1 - e^{-\alpha d}) \times 1 \text{ W}$. Using $d = 250 \text{ nm}$, the characteristic silicon nitride thickness of our cavities, and $\alpha = 0.2 \text{ cm}^{-1}$, a characteristic absorption coefficient [78] that is consistent with the types of cavities (and their quality factors) that we envision using, we get $|\Delta\nu| \approx (2\pi)10 \text{ MHz}$, which is much smaller than the linewidths of the highly overcoupled cavities [with coupling rates κ_{ex} between $(2\pi)0.9$ to $(2\pi)27 \text{ GHz}$] considered in this work.

-
- [1] J.-W. Pan, Z.-B. Chen, C.-Y. Lu, H. Weinfurter, A. Zeilinger, and M. Żukowski, Multiphoton entanglement and interferometry, *Rev. Mod. Phys.* **84**, 777 (2012).
- [2] P. Kok, W. J. Munro, K. Nemoto, T. C. Ralph, J. P. Dowling, and G. J. Milburn, Linear optical quantum computing with photonic qubits, *Rev. Mod. Phys.* **79**, 135 (2007).
- [3] M. K. Bhaskar, R. Riedinger, B. Machielse, D. S. Levonian, C. T. Nguyen, E. N. Knall, H. Park, D. Englund, M. Lončar, D. D. Sukachev, and M. D. Lukin, Experimental demonstration of memory-enhanced quantum communication, *Nature (London)* **580**, 60 (2020).
- [4] N. Friis, D. Orsucci, M. Skotiniotis, P. Sekatski, V. Dunjko, H. J. Briegel, and W. Dür, Flexible resources for quantum metrology, *New J. Phys.* **19**, 063044 (2017).
- [5] E. Knill, R. Laflamme, and W. H. Zurek, Resilient quantum computation: Error models and thresholds, *Proc. R. Soc. London A* **454**, 365 (1998).
- [6] X. Ding, Y. He, Z.-C. Duan, N. Gregersen, M.-C. Chen, S. Unsleber, S. Maier, C. Schneider, M. Kamp, S. Höfling, C.-Y. Lu, and J.-W. Pan, On-demand single photons with high extraction efficiency and near-unity indistinguishability from a resonantly driven quantum dot in a micropillar, *Phys. Rev. Lett.* **116**, 020401 (2016).
- [7] A. Kuhn, M. Hennrich, and G. Rempe, Deterministic single-photon source for distributed quantum networking, *Phys. Rev. Lett.* **89**, 067901 (2002).
- [8] M. Keller, B. Lange, K. Hayasaka, W. Lange, and H. Walther, Continuous generation of single photons with controlled waveform in an ion-trap cavity system, *Nature (London)* **431**, 1075 (2004).
- [9] B. C. Pursley, S. G. Carter, M. K. Yakes, A. S. Bracker, and D. Gammon, Picosecond pulse shaping of single photons using quantum dots, *Nat. Commun.* **9**, 115 (2018).
- [10] T. Wilk, S. C. Webster, H. P. Specht, G. Rempe, and A. Kuhn, Polarization-controlled single photons, *Phys. Rev. Lett.* **98**, 063601 (2007).
- [11] G. Juska, V. Dimastrodonato, L. O. Mereni, A. Gocalinska, and E. Pelucchi, Towards quantum-dot arrays of entangled photon emitters, *Nat. Photon.* **7**, 527 (2013).
- [12] J. McKeever, A. Boca, A. D. Boozer, R. Miller, J. R. Buck, A. Kuzmich, and H. J. Kimble, Deterministic generation of single photons from one atom trapped in a cavity, *Science* **303**, 1992 (2004).
- [13] M. Hijlkema, B. Weber, H. P. Specht, S. C. Webster, A. Kuhn, and G. Rempe, A single-photon server with just one atom, *Nat. Phys.* **3**, 253 (2007).
- [14] D. V. Reddy, N. Otrooshi, S. W. Nam, R. P. Mirin, and V. B. Verma, Broadband polarization insensitivity and high detection efficiency in high-fill-factor superconducting microwire single-photon detectors, *APL Photon.* **7**, 051302 (2022).
- [15] Y. Liu, M. Davanço, V. Aksyuk, and K. Srinivasan, Electromagnetically induced transparency and wideband wavelength conversion in silicon nitride microdisk optomechanical resonators, *Phys. Rev. Lett.* **110**, 223603 (2013).
- [16] W. Bogaerts, P. De Heyn, T. Van Vaerenbergh, K. De Vos, S. Kumar Selvaraja, T. Claes, P. Dumon, P. Bienstman, D. Van Thourhout, and R. Baets, Silicon microring resonators, *Laser Photon. Rev.* **6**, 47 (2012).
- [17] L. Zhang, L. Jie, M. Zhang, Y. Wang, Y. Xie, Y. Shi, and D. Dai, Ultrahigh- Q silicon racetrack resonators, *Photon. Res.* **8**, 684 (2020).
- [18] T. G. Tiecke, J. D. Thompson, N. P. De Leon, L. R. Liu, V. Vuletić, and M. D. Lukin, Nanophotonic quantum phase switch with a single atom, *Nature (London)* **508**, 241 (2014).
- [19] A. Boca, R. Miller, K. M. Birnbaum, A. D. Boozer, J. McKeever, and H. J. Kimble, Observation of the vacuum Rabi spectrum for one trapped atom, *Phys. Rev. Lett.* **93**, 233603 (2004).
- [20] B. Dayan, A. S. Parkins, T. Aoki, E. P. Ostby, K. J. Vahala, and H. J. Kimble, A photon turnstile dynamically regulated by one atom, *Science* **319**, 1062 (2008).
- [21] J. Volz, M. Scheucher, C. Junge, and A. Rauschenbeutel, Non-linear π phase shift for single fibre-guided photons interacting with a single resonator-enhanced atom, *Nat. Photon.* **8**, 965 (2014).
- [22] A. Reiserer, N. Kalb, G. Rempe, and S. Ritter, A quantum gate between a flying optical photon and a single trapped atom, *Nature (London)* **508**, 237 (2014).
- [23] P. Samutpraphoot, T. Đorđević, P. L. Ocola, H. Bernien, C. Senko, V. Vuletić, and M. D. Lukin, Strong coupling of two individually controlled atoms via a nanophotonic cavity, *Phys. Rev. Lett.* **124**, 063602 (2020).

- [24] R. J. Thompson, G. Rempe, and H. J. Kimble, Observation of normal-mode splitting for an atom in an optical cavity, *Phys. Rev. Lett.* **68**, 1132 (1992).
- [25] Q. A. Turchette, C. J. Hood, W. Lange, H. Mabuchi, and H. J. Kimble, Measurement of conditional phase shifts for quantum logic, *Phys. Rev. Lett.* **75**, 4710 (1995).
- [26] H. Alaeian, R. Ritter, M. Basic, R. Löw, and T. Pfau, Cavity QED based on room temperature atoms interacting with a photonic crystal cavity: A feasibility study, *Appl. Phys. B* **126**, 25 (2020).
- [27] A. W. Elshaari, W. Pernice, K. Srinivasan, O. Benson, and V. Zwiller, Hybrid integrated quantum photonic circuits, *Nat. Photon.* **14**, 285 (2020).
- [28] T.-H. Chang, X. Zhou, M. Zhu, B. M. Fields, and C.-L. Hung, Efficiently coupled microring circuit for on-chip cavity QED with trapped atoms, *Appl. Phys. Lett.* **117**, 174001 (2020).
- [29] X. Lu, A. McClung, and K. Srinivasan, High- Q slow light and its localization in a photonic crystal microring, *Nat. Photon.* **16**, 66 (2022).
- [30] C. Li, X. Chai, B. Wei, J. Yang, A. Daruwalla, F. Ayazi, and C. Raman, Cascaded collimator for atomic beams traveling in planar silicon devices, *Nat. Commun.* **10**, 1831 (2019).
- [31] G. D. Martinez, C. Li, A. Staron, J. Kitching, C. Raman, and W. R. McGehee, A chip-scale atomic beam clock, *Nat. Commun.* **14**, 3501 (2023).
- [32] L. Stern, R. Zektzer, N. Mazurski, and U. Levy, Enhanced light-vapor interactions and all optical switching in a chip scale micro-ring resonator coupled with atomic vapor, *Laser Photon. Rev.* **10**, 1016 (2016).
- [33] R. Ritter, N. Gruhler, H. Dobbertin, H. Kübler, S. Scheel, W. Pernice, T. Pfau, and R. Löw, Coupling thermal atomic vapor to slot waveguides, *Phys. Rev. X* **8**, 021032 (2018).
- [34] R. Zektzer, X. Lu, K. T. Hoang, R. Shrestha, S. Austin, F. Zhou, A. Chanana, G. Holland, D. Westly, P. Lett, A. V. Gorshkov, and K. Srinivasan, Strong interactions between integrated microresonators and alkali atomic vapors: Towards single-atom, single-photon operation, *Optica* **11**, 1376 (2024).
- [35] N. H. Lindner and T. Rudolph, Proposal for pulsed on-demand sources of photonic cluster state strings, *Phys. Rev. Lett.* **103**, 113602 (2009).
- [36] H. Pichler, S. Choi, P. Zoller, and M. D. Lukin, Universal photonic quantum computation via time-delayed feedback, *Proc. Natl. Acad. Sci. USA* **114**, 11362 (2017).
- [37] M. Pöllinger, D. O'Shea, F. Warken, and A. Rauschenbeutel, Ultrahigh- q tunable whispering-gallery-mode microresonator, *Phys. Rev. Lett.* **103**, 053901 (2009).
- [38] J. D. Thompson, T. G. Tiecke, N. P. de Leon, J. Feist, A. V. Akimov, M. Gullans, A. S. Zibrov, V. Vuletić, and M. D. Lukin, Coupling a single trapped atom to a nanoscale optical cavity, *Science* **340**, 1202 (2013).
- [39] T. Aoki, B. Dayan, E. Wilcut, W. P. Bowen, A. S. Parkins, T. J. Kippenberg, K. J. Vahala, and H. J. Kimble, Observation of strong coupling between one atom and a monolithic microresonator, *Nature (London)* **443**, 671 (2006).
- [40] I. Shomroni, S. Rosenblum, Y. Lovsky, O. Bechler, G. Guendelman, and B. Dayan, All-optical routing of single photons by a one-atom switch controlled by a single photon, *Science* **345**, 903 (2014).
- [41] R. Raussendorf, D. E. Browne, and H. J. Briegel, Measurement-based quantum computation on cluster states, *Phys. Rev. A* **68**, 022312 (2003).
- [42] C. Junge, D. O'Shea, J. Volz, and A. Rauschenbeutel, Strong coupling between single atoms and nontransversal photons, *Phys. Rev. Lett.* **110**, 213604 (2013).
- [43] D. O'Shea, C. Junge, J. Volz, and A. Rauschenbeutel, Fiber-optical switch controlled by a single atom, *Phys. Rev. Lett.* **111**, 193601 (2013).
- [44] A. Espinosa-Soria and A. Martinez, Transverse spin and spin-orbit coupling in silicon waveguides, *IEEE Photon. Technol. Lett.* **28**, 1561 (2016).
- [45] R. Zektzer, E. Talker, Y. Barash, N. Mazurski, and U. Levy, Chiral light-matter interactions in hot vapor-clad waveguides, *Optica* **6**, 15 (2019).
- [46] X. Zhou, H. Tamura, T.-H. Chang, and C.-L. Hung, Coupling single atoms to a nanophotonic whispering-gallery-mode resonator via optical guiding, *Phys. Rev. Lett.* **130**, 103601 (2023).
- [47] S. Xie, Y. Zhang, Y. Hu, S. Veilleux, and M. Dagenais, On-chip Fabry-Perot Bragg grating cavity enhanced four-wave mixing, *ACS Photon.* **7**, 1009 (2020).
- [48] M. Notomi, Manipulating light with strongly modulated photonic crystals, *Rep. Prog. Phys.* **73**, 096501 (2010).
- [49] E. Meyer-Scott, C. Silberhorn, and A. Migdall, Single-photon sources: Approaching the ideal through multiplexing, *Rev. Sci. Instrum.* **91**, 041101 (2020).
- [50] Y. Jiang, X. Han, Y. Li, H. Xiao, H. Huang, P. Zhang, A. Dubey, M. Yuan, T. G. Nguyen, A. Boes, Y. Li, G. Ren, J. Xue, Q. Hao, Y. Su, A. Mitchell, and Y. Tian, High-speed optical mode switch in lithium niobate on insulator, *ACS Photon.* **10**, 2257 (2023).
- [51] G. S. Vasilev, D. Ljunggren, and A. Kuhn, Single photons made-to-measure, *New J. Phys.* **12**, 063024 (2010).
- [52] S. Parkins and T. Aoki, Microtoroidal cavity QED with fiber overcoupling and strong atom-field coupling: A single-atom quantum switch for coherent light fields, *Phys. Rev. A* **90**, 053822 (2014).
- [53] A. Kuhn, M. Hennrich, T. Bondo, and G. Rempe, Controlled generation of single photons from a strongly coupled atom-cavity system, *Appl. Phys. B* **69**, 373 (1999).
- [54] M. Hennrich, T. Legero, A. Kuhn, and G. Rempe, Vacuum-stimulated raman scattering based on adiabatic passage in a high-finesse optical cavity, *Phys. Rev. Lett.* **85**, 4872 (2000).
- [55] T. Utsugi, A. Goban, Y. Tokunaga, H. Goto, and T. Aoki, Gaussian-wave-packet model for single-photon generation based on cavity quantum electrodynamics under adiabatic and nonadiabatic conditions, *Phys. Rev. A* **106**, 023712 (2022).
- [56] A. V. Gorshkov, T. Calarco, M. D. Lukin, and A. S. Sørensen, Photon storage in Λ -type optically dense atomic media. iv. Optimal control using gradient ascent, *Phys. Rev. A* **77**, 043806 (2008).
- [57] P. E. Barclay, K. Srinivasan, O. Painter, B. Lev, and H. Mabuchi, Integration of fiber-coupled high- Q SiN_x microdisks with atom chips, *Appl. Phys. Lett.* **89**, 131108 (2006).
- [58] M. Radulaski, T. M. Babinec, K. Müller, K. G. Lagoudakis, J. L. Zhang, S. Buckley, Y. A. Kelaita, K. Alassaad, G. Ferro, and J. Vučković, Visible photoluminescence from cubic (3C) silicon carbide microdisks coupled to high quality whispering gallery modes, *ACS Photon.* **2**, 14 (2015).

- [59] E. Gomez, S. Aubin, L. A. Orozco, and G. D. Sprouse, Lifetime and hyperfine splitting measurements on the $7s$ and $6p$ levels in rubidium, *J. Opt. Soc. Am. B* **21**, 2058 (2004).
- [60] H.-S. Zhong, Y. Li, W. Li, L.-C. Peng, Z.-E. Su, Y. Hu, Y.-M. He, X. Ding, W. Zhang, H. Li, L. Zhang, Z. Wang, L. You, X.-L. Wang, X. Jiang, L. Li, Y.-A. Chen, N.-L. Liu, C.-Y. Lu, and J.-W. Pan, 12-photon entanglement and scalable scattershot boson sampling with optimal entangled-photon pairs from parametric down-conversion, *Phys. Rev. Lett.* **121**, 250505 (2018).
- [61] H. Wang *et al.*, Towards optimal single-photon sources from polarized microcavities, *Nat. Photon.* **13**, 770 (2019).
- [62] D. P. Ornelas-Huerta, A. N. Craddock, E. A. Goldschmidt, A. J. Hachtel, Y. Wang, P. Bienias, A. V. Gorshkov, S. L. Rolston, and J. V. Porto, On-demand indistinguishable single photons from an efficient and pure source based on a Rydberg ensemble, *Optica* **7**, 813 (2020).
- [63] C. Xiong, X. Zhang, Z. Liu, M. J. Collins, A. Mahendra, L. G. Helt, M. J. Steel, D.-Y. Choi, C. J. Chae, P. H. W. Leong, and B. J. Eggleton, Active temporal multiplexing of indistinguishable heralded single photons, *Nat. Commun.* **7**, 10853 (2016).
- [64] G. Moille, D. Westly, E. F. Perez, M. Metzler, G. Simelgor, and K. Srinivasan, Integrated buried heaters for efficient spectral control of air-clad microresonator frequency combs, *APL Photon.* **7**, 126104 (2022).
- [65] D. Zhu, L. Shao, M. Yu, R. Cheng, B. Desiatov, C. J. Xin, Y. Hu, J. Holzgrafe, S. Ghosh, A. Shams-Ansari, E. Puma, N. Sinclair, C. Reimer, M. Zhang, and M. Lončar, Integrated photonics on thin-film lithium niobate, *ACS Photon.* **13**, 242 (2021).
- [66] B. Hacker, S. Welte, G. Rempe, and S. Ritter, A photon–photon quantum gate based on a single atom in an optical resonator, *Nature (London)* **536**, 193 (2016).
- [67] A. Reiserer, S. Ritter, and G. Rempe, Nondestructive detection of an optical photon, *Science* **342**, 1349 (2013).
- [68] L.-M. Duan and H. J. Kimble, Scalable photonic quantum computation through cavity-assisted interactions, *Phys. Rev. Lett.* **92**, 127902 (2004).
- [69] L.-M. Duan, A. Kuzmich, and H. J. Kimble, Cavity QED and quantum-information processing with “hot” trapped atoms, *Phys. Rev. A* **67**, 032305 (2003).
- [70] M. Yu, D. Barton III, R. Cheng, C. Reimer, P. Kharel, L. He, L. Shao, D. Zhu, Y. Hu, H. R. Grant, L. Johansson, Y. Okawachi, A. L. Gaeta, M. Zhang, and M. Lončar, Integrated femtosecond pulse generator on thin-film lithium niobate, *Nature (London)* **612**, 252 (2022).
- [71] S. Austin, Code-for-VQED, GitHub repository (2026), <https://github.com/sharoon97/Code-for-VQED>.
- [72] Y. Shi and E. Waks, Deterministic generation of multidimensional photonic cluster states using time-delay feedback, *Phys. Rev. A* **104**, 013703 (2021).
- [73] S. Bartolucci, P. M. Birchall, M. Gimeno-Segovia, E. Johnston, K. Kieling, M. Pant, T. Rudolph, J. Smith, C. Sparrow, and M. D. Vidrighin, Creation of entangled photonic states using linear optics, [arXiv:2106.13825](https://arxiv.org/abs/2106.13825).
- [74] P. N. Melentiev, P. A. Borisov, and V. I. Balykin, Zeeman laser cooling of ^{85}Rb atoms in transverse magnetic field, *J. Exp. Theor. Phys.* **98**, 667 (2004).
- [75] E. Will, L. Masters, A. Rauschenbeutel, M. Scheucher, and J. Volz, Coupling a single trapped atom to a whispering-gallery-mode microresonator, *Phys. Rev. Lett.* **126**, 233602 (2021).
- [76] G. Huang, E. Lucas, J. Liu, A. S. Raja, G. Lihachev, M. L. Gorodetsky, N. J. Engelsen, and T. J. Kippenberg, Thermorefractive noise in silicon-nitride microresonators, *Phys. Rev. A* **99**, 061801(R) (2019).
- [77] Q. Li, T. C. Briles, D. A. Westly, T. E. Drake, J. R. Stone, B. R. Ilic, S. A. Diddams, S. B. Papp, and K. Srinivasan, Stably accessing octave-spanning microresonator frequency combs in the soliton regime, *Optica* **4**, 193 (2017).
- [78] C. Zhang, G. Kang, J. Wang, S. Wan, C. Dong, Y. Pan, and J. Qu, Photonic thermometer by silicon nitride microring resonator with milli-kelvin self-heating effect, *Measurement* **188**, 110494 (2022).