

A SysML Representation of the Wireless Factory Work-cell

Enabling real-time observation and control by modeling significant architecture, components, and information flows

Richard Candell, Mohamed Kashef, Yongkang Liu, and Sebti Foufou

Received: date / Accepted: date

Abstract A fourth industrial revolution, occurring in global manufacturing, provides a vision of future manufacturing systems that incorporate highly dynamic physical systems, robust and responsive communications systems, and computing paradigms to maximize efficiency, enable mobility, and realize the promises of the digital factory. Wireless technology is a key enabler of that vision. A comprehensive graphical model is developed for a generic wireless factory work-cell which employs the Systems Modeling Language (SysML), a standardized and semantically rich modeling language, to link the physical and network domains in such a cyber-physical system (CPS). The proposed model identifies the structural primitives, interfaces, and behaviors of the highly-connected factory work-cell in which wireless technology is used for significant data flows involved in control algorithms. The model includes the parametric definitions to encapsulate information loss, delay, and mutation associated with the wireless network, and it identifies pertinent wireless information flows.

Keywords industrial wireless, factory communications, networked control systems, manufacturing, cyber-physical systems, SysML

1 Introduction

The fourth industrial revolution promises unparalleled productivity and capability advances in manufacturing. To support the manufacturing industry in this conversion, various

programs have been established in several countries such as Smart Manufacturing in the U.S. [6] and Industry 4.0 in Europe [35, 38]. Propelled by economic pressure toward greater efficiency, factory agility, and product customization, future factories will have the technological ability to adapt to customer demands quickly, modify manufacturing processes automatically based on quality feedback, and fabricate products with a reduced environmental impact. Technological advances required for smart manufacturing to be successful include collaborative and mobile robotics [29], distributed machine autonomy based on artificial intelligence [39], improved process observability [59], and a high degree of interconnectivity among automation resources [32]. Work-cells are self-contained units of operation within a factory [14, 22, 45]. These work-cells are composed of various machines, conveyors, motors, edge devices, and robots. Robots will work together and with people to accomplish complex tasks or to tending to other machines within the work-cell. Robots will have the ability to roam between work-cells within a factory, learn their roles quickly, become aware of edge devices, and communicate with other actors within the work-cell to accomplish their goals. Efficient communications between robots and the other players in the work-cell are essential to the fulfillment of the robot-related tasks.

Current manufacturing architectures use wired connections through field-bus and industrial Ethernet protocols for sensing and real-time control [51, 64]. Indeed, through advances in time-sensitive networking, many of the promises of smart manufacturing are being realized; however, the true goals of smart manufacturing require a large deployment of sensing and actuation devices and mobile, perhaps autonomous, robotics actors [32]. The use of wires precludes mobility and makes deployment of edge devices more expensive as each requires power, cables, and conduit for communication. By adopting wireless for both sensing and control of machines within the work-cell, a lower-cost, unteth-

Richard Candell, Mohamed Kashef, and Yongkang Liu
National Institute of Standards and Technology
100 Bureau Drive M/S 8230 Tel.: +001-301-975-2000
E-mail: {richard.candell,mohamed.kashef,yongkang.liu}@nist.gov

Sebti Foufou
University of Burgundy, Dijon, France
sfoufou@u-bourgogne.fr

ered operation is achievable¹. Once wireless is adopted as the primary mode of communication, questions arise as to the required latency, reliability, and scale of the wireless network especially when the network is used for the control of machines and the assurance of safety [32].

The work presented here addresses the present need for a comprehensive architectural model of the factory work-cell in which wireless is a preferred mechanism for carrying information within the work-cell. We begin with an architectural analysis of the future collaborative work-cell that includes edge devices, robots, vision systems, and supervisory controllers. Our architectural analysis includes structural components, information flows, and parametric elements of the work-cell. We identify factors that limit reliability, latency, and scalability of the wireless network, and we conclude with a discussion of significant information flows. Significant information flows are defined as operationally critical or safety-related. Our contributions are:

- ★ First, we develop a comprehensive and extensible architectural model using the Systems Modeling Language (SysML) that provides primitives for describing the physical and networking components of a work-cell with parametric constraints²;
- ★ Second, we provide a framework for analyzing cross-domain interactions of complex wireless work-cell deployments; and
- ★ Third, significant information flows are identified, annotated with rate constraints.

The remainder of this paper is organized as follows: In Section 2, previous related work is discussed and our motivation for constructing a model is presented. A brief introduction to systems modeling is presented in Section 3 and provides a primer on the SysML language. The conceptual architecture of the model providing a concept-of-usage is proposed in Section 4, followed by a detailed exposition of each package in Section 5. Then, in Section 6, significant information flows are discussed through introducing a case study. Section 7 concludes the paper and identifies opportunities for future research.

2 Related Work

Current modeling work on factory work-cells is mainly aimed at defining and characterizing the subsystems, such as human staff, robots, and machine tools, in individual applications. By following blueprints (schematics) of production

tasks, the work flow can be divided into separate assignments which are distributed by a task dispatch system to individual machines [36]. Analytical models are thus obtained for performance analysis in work-cells. As an example, a mathematical model for real-time performance analysis of a gantry work-cell with robots is established with the timing and the randomness of tasks and disruptions are captured [53]. In [52], the same model is used to investigate the system natural properties such the system cycle and waiting times and to identify bottlenecks through studying the sensitivity of each machine. Similarly, the steady state analysis for production lines with uncertainties is performed through various decomposition methods [16, 28, 66]. In [16], a decomposition method is presented for the analysis of continuous flow lines. The presented model is used to analyze flow lines with single and multiple failure mode machines and machines subject to aging and having up and down times. In [66], a model to evaluate the performance of transfer lines with unreliable machines and finite transfer-delay buffers is presented. A decomposition method is introduced to model the transfer line, using the general-exponential distributions instead of the exponential distributions to approximate the repair time distributions of the fictitious machines. In [28], the authors present a model for evaluating the production rate and distribution of inventory of a closed-loop manufacturing system with unreliable machines and finite buffers. The model accounts for the different sets of machines that could cause blockage or starvation to other machines. In [13, 40], the performance analysis modeling for serial production lines with disruptions is explored by studying the impact of each individual downtime event in terms of permanent production loss and financial cost. These analytical models generally work well for simple systems with small number of components or few interactions between various equipment. Also, the analytical models can be used to abstract industrial systems to understand various performance trends without studying various details. As a result, we introduce a comprehensive model that include network and production impacts on the industrial work-cell.

Furthermore, the reconfigurable work-cell architecture is widely considered for automated manufacturing. The main advantage of reconfigurable work-cells lies in the flexibility of reconfiguration of work-cell components to adapt to varying production requirements where the assembly of the work cell is optimized for each specific task [14]. In the work-cell that hosts robots, robots are installed therein to allow for autonomous configuration within their workspace [22, 26, 47]. Approaches and performance criteria for reconfigurable robotic systems have recent developments in control architectures to achieve various levels of reconfigurability [25]. The National Institute of Standards and Technology (NIST) has defined a Network of Things (NoT) model which can depict the structure of work-cells by a group of

¹ The power for untethered operation can be achieved through the use of rechargeable batteries to power the untethered machine or robot for enough operating period.

² We make the model publicly available for download. A valid license of MagicDraw 18.5 is required to use the model. A web-based report of the model is provided for read-only access.

NoT building blocks and model the behaviors of individual components in a work-cell [62]. The NIST NoT model is focused primarily on sensor networks and the collection of data. Actuation is cursorily noted, and, as such, cross-domain interactions between the physical system and the network are not addressed. Several other robotic work-cell architectures are discussed in the literature. In [49], a reference model for a control system functional architecture applied to open architecture robot controllers is presented. In [12], a methodology to develop self-adaptive factory automation solutions is illustrated, using a novel modular simulation based method. With the increase in complexity and reconfigurability of work-cells, studying various production criteria and networks impacts requires introducing new models to capture these interactions and to be abstract enough to model different configurations and scenarios of industrial work-cells.

In a work-cell model, data flows are used to capture the trajectory of system information exchange between work-cell components and identify their roles in specific operations [49]. For example, safety-related operations employ the vision system and various proximity sensors that generate proximity data and transmit them to the safety manager to define safety zones in an automotive assembly work-cell [46]. In another example, data flows are enabled in a work-cell to capture human operator gestures from embedded cameras in human-robot collaborations [61]. These gestures can be later regenerated in simulators based on the transmitted position data from the field to optimize work-cell safety operations [19]. Currently, most of the work-cell information in these scenarios are transmitted by wired networks. Wireless networks have gained increasing interests to enable data flows in the highly connected work-cells. Wireless standard bodies have proposed their network reference models in factory environments which include the work-cell cases in the data-centric architecture [1, 2]. In these models, individual work-cells are treated as a subnetwork of field instruments attached with data aggregations that manage network connections and transfer data traffic to edge and cloud servers in various applications. Wireless connections are featured with flexible network topology to agree with a variety of transmission needs, especially in reconfigurable work-cells. Meanwhile, data traffic flows are characterized by select performance metrics, such as transmission latency and link reliability, to categorize industrial use cases [2].

Current modeling efforts set the boundaries of their systems of study at the edge devices without further discussions on the impact of wireless performance on the operations of industrial systems. For example, the abstracted disruptions in [13, 40] that cause plant downtimes may include wireless network impacts which are not yet treated distinguishably with specific characteristics of wireless networks. As indicated by the earlier empirical studies [41], such phys-

ical systems may have different responses to network performance which will vary with the operational configuration such as the served “application” and the deployed control algorithms. In this paper, we incorporate the features of wireless communications networks into the modeling architecture of physical work-cells such that cross-domain interactions may be studied. Prior to introducing the model for wireless incorporation, we first provide the reader an introduction to SysML in the following section.

3 Systems Modeling Using SysML

The goal of modeling a system is the capture of knowledge of a process in a simplified way [55]. A secondary goal of a system model is to provide a level of abstraction that may allow for the discovery of new knowledge such as how two systems will interact. There are multiple ways of designing and presenting system models. Well-behaved systems can be represented by a system of equations using mathematical tools [37]. Such models provide excellent constraint definition, but lack the semantics to describe architecture and detailed information flow. Moreover, by deploying functional block diagrams, we are able to capture major functional components and flow of information or material. As shown in Fig. 1, a physical process interacts with a control system through a wireless network. Measured values, Y , from sensors flow to the controller through a wireless network and arrive at the controller delayed and modified, \bar{Y} . Similarly, commands, U , flows from the controller to the actuators through the wireless network. Such diagrams may be used to model feedback control systems in which the origination and routing of information are immaterial for study. However, the architecture and interfaces remain at a very high level of abstraction making analysis difficult. In such cases, delay and loss using such tools are often modeled stochastically. Using architectural diagrams helps identify components, interfaces, and information flow. For factory systems, architectural block diagrams are often manifested as schematics. However, such diagrams have their own limits in industrial practices. On one hand, they lack the semantics necessary to describe the constraints that formal equations and functional block diagrams offer. Meanwhile, they also lack the capability of capturing behaviors or complex interactions between the physical system and the information infrastructure such as a wireless network.

An alternative to schematic diagrams is SysML [48]. SysML is a general purpose modeling language that is often used for model-based systems engineering (MBSE) practice within industrial systems [31]. SysML provides structural, behavioral, and parametric semantics for the analysis of complex systems. For examples, systems analysis using SysML enables capturing and communicating system requirements and design which include hardware, software,

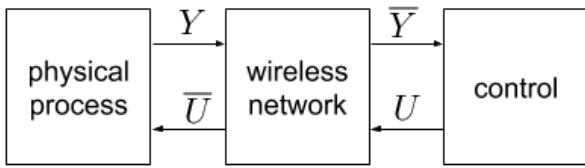

Fig. 1 Functional block diagram of a cyber-physical system in which a physical process and an automation system interact through a wireless network.

firmware, information flows, and processes with graphical notations. Within the factory automation industry, engineers are adopting SysML in the form of MBSE to develop realizable operational models of the factory and data flow processes. MBSE models address verification of design through executable simulations depending on the modeling tool. The SysML specification is defined in [48]. In SysML, the basic semantic constructs of the language are Packages, Blocks, Ports, Interfaces, and Constraints, in addition to the constructs provided by the Unified Modeling Language (UML). Packages are logical grouping of model elements. Package relationships are captured using the package diagram (PKG). Relationships of these constructs are captured in the block definition diagram (BDD). The internal composition and connectivity of parts are captured in the internal block diagram (IBD). SysML includes other types of diagrams and semantic constructs that are not required for this analysis and are not explained here. The SysML model is comprehensive; however, the size and number of diagrams within the model are too extensive to include within this paper. Therefore, the reader is encouraged to explore the SysML model defined in [9]. A useful primer on SysML may be found in [24].

Examples of the use cases and methodologies of using different graphical models for the analysis of manufacturing systems are explored in [3, 34, 42, 43]. In [58], SysML is used to capture both composition and behavior of an additive manufacturing work-cell. A survey of applying graphical modeling languages in capturing information flows within a product service system which may be applied to manufacturing enterprises [20]. Our approach compliments these previous examples by combining the operational and wireless information transport systems together in a single model, thereby facilitating a single model that may be used for simulation and other systems engineering analyses.

While various architectures for the work-cell exist as exemplified in the literature, a common language and framework for communicating architecture and information flow has not been established for cross-domain interactions between the manufacturing system and its supporting communication networks. SysML contains the semantics for such engineering capture and provides an industry accepted language for communicating composition, interfaces, and information flow. Moreover, SysML provides the semantics

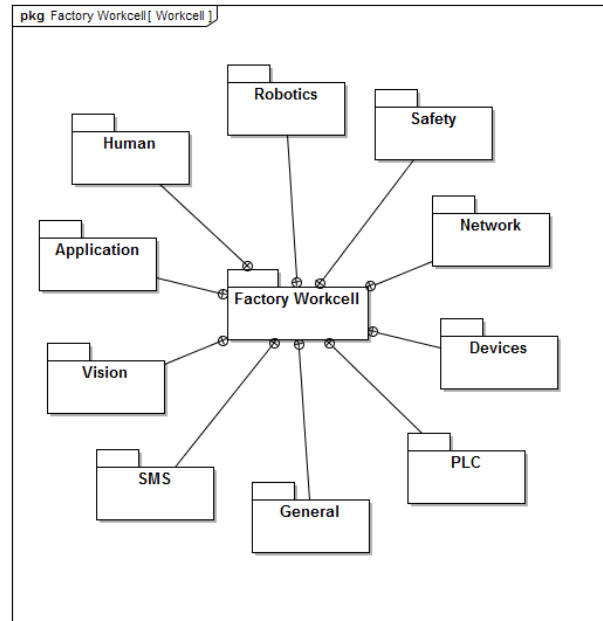

Fig. 2 SysML package diagram showing the logical containment of the factory work-cell structural elements.

for assigning properties to any model element such that those properties are made available for analysis using other tools such as Protégé [60] and the Web Ontology Language (OWL) [63]. It is important to understand that while SysML provides semantics for a formal capture of architecture, information flow, and parametric constraints, it may also be used for a higher-degree of abstraction provided by the functional block diagrams.

4 Conceptual Representation

The remainder of this work describes a reusable model for representing a comprehensive wireless factory work-cell using the semantic constructs of SysML. We now follow with an exposition of our model beginning with the conceptual model followed by a detailed description of each component within the model. When discussing the model, the SysML term, *block*, is omitted for the sake of brevity where the meaning is clear.

4.1 Packages

The factory work-cell is decomposed into one general and nine major structural packages as shown in Fig. 2. Packages include major logical groupings of structure within the model. These packages are enumerated in the following paragraphs.

4.1.1 General

A set of reusable structural elements that is used for conceptual modeling or extended to produce more complex model elements. Each of the sub-packages within the General package extends basic features. The sub-packages within General include time and constraints for data, electro-magnetics, and motion.

4.1.2 Network

Describes the components, blocks, interfaces, and limiting factors of the industrial wireless network (IWN). The IWN is modeled as the radio channel and the services provided by the network. Limiting factors are modeled as parametric equations associated with the radio channel and the services.

4.1.3 Application

This package contains the model elements describing a component of behavioral functionality typically implemented within software or firmware but could be implemented in hardware. It describes the features and constraints of factory operation such as the logic of a supervisory controller or the feedback controller of a robot arm. The Application sets the performance requirements of the wireless network, i.e., the factory network performance requirements are derived from the requirements of the applications deployed to a work-cell.

4.1.4 Devices

Describes the types of devices found within the factory work-cell to include any device that interacts with the environment such as wired and wireless input-output (IO) devices including sensors and actuators.

4.1.5 Robotics

Describes the computational and communicative components of robot control including sensing, actuation, and command. Description of the robot itself is inconsequential to communication and therefore not included in the model.

4.1.6 PLC

Describes the supervisory control components commonly handled by one or more programmable logic controller (PLC) components. This package includes the elements responsible for coordination of actors and handling of most input-output.

4.1.7 Safety

Describes the allocation of safety qualities typically included in the supervisory controller. The Safety package includes devices, monitoring, and actuation of the safety behaviors within the factory work-cell.

4.1.8 Vision

Describes the allocation of features to optical monitoring and tracking which are typical to the collaborative robotic work-cell.

4.1.9 Spectrum Monitoring System (SMS)

Describes the qualities and interfaces of a factory spectrum monitoring system projected into the factory work-cell. The SMS includes monitoring nodes and agents localized to the work-cell and connected to the automation system for real-time adaptation to changing multi-path and interference.

4.1.10 Human

Describes the features associated with human beings such as human motion, tasks, and carried equipment such as portable computing and communication devices.

Several examples of how to use the model are provided within the model [9]. Examples include: a robotic force-torque leader-follower, a robotic force-torque limiter, a collision avoidance, and a robotic pick and place work-cell. The parametric constraints are provided as examples and are intended to be used for communication to project stakeholders or replaced with executable computer code such as MATLAB or Python scripts, thereby making the model useful for simulation depending on the modeling tool selected.

4.2 Conceptual Architecture

The conceptual architecture of the wireless work-cell model is depicted in Fig. 3. All the packages are included in this architecture, and the connections and relations between blocks are defined using the SysML semantics. This figure serves to orient the reader during the presentation of detailed model decomposition in Section 5. The work-cell model is composed of at least one Industrial Wireless Network (IWN) block and at least one Device block. More IWN blocks are used when multiple wireless networks coexist within the industrial work-cell. Applications are associated with Devices and performance constraints are applied to Applications. In this model, the Wireless Device is a subclass of Device, and the Controller is a further derivation of the wireless device. Moreover, the Controller is an abstract specialization of a

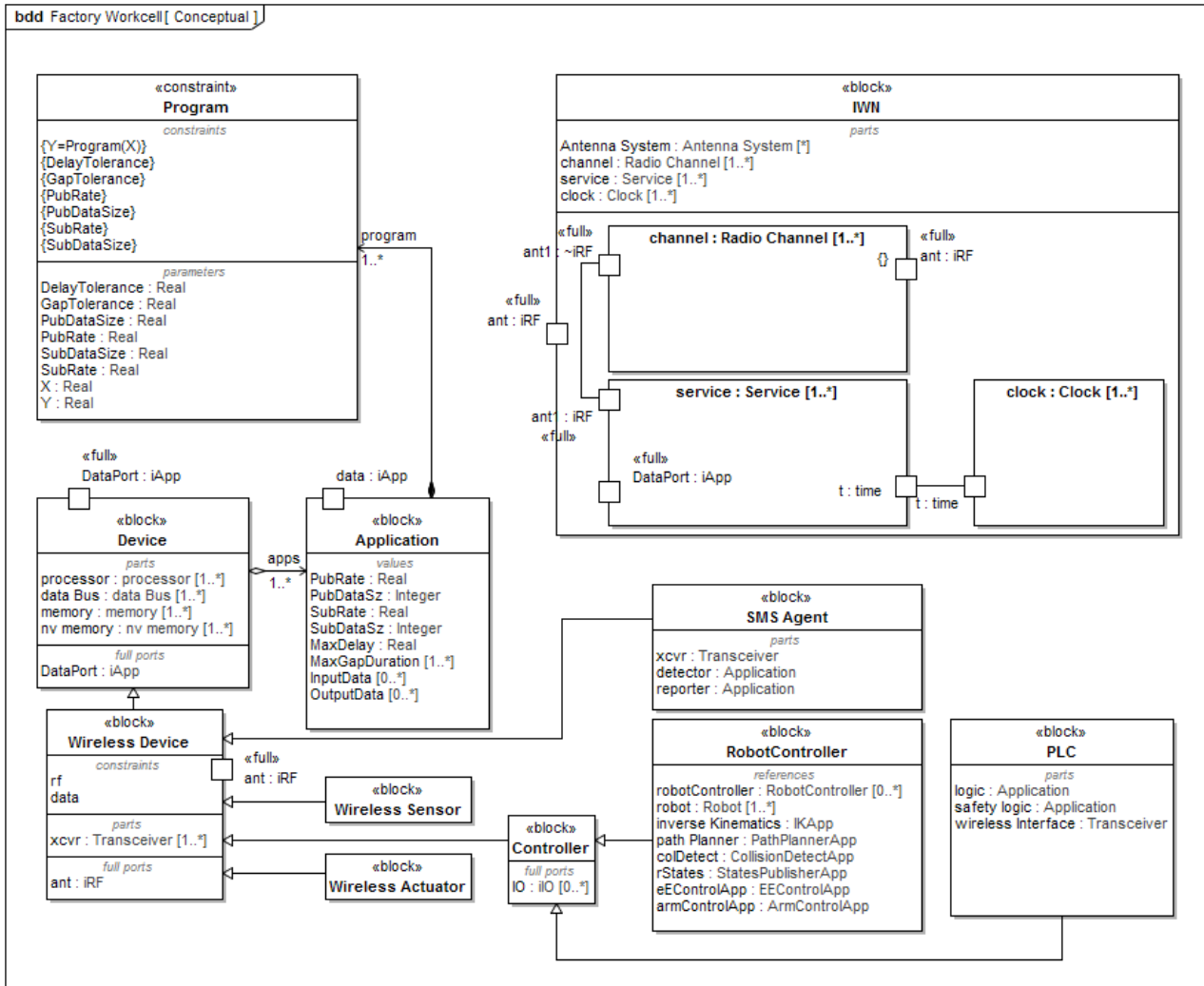

Fig. 3 Architecture of the conceptual work-cell captured as a SysML block definition diagram. In this diagram, only the most generalized blocks necessary to construct a work-cell scenario are shown. More application-specific scenarios may be developed by deriving new blocks from the constructs shown here. The shapes and connectors used for expressing this model are defined in the SysML specification [48].

wireless device that represents all types of devices intended to control other processes. The behaviour of a PLC or Robot is represented through two packages in the model. The production related behaviour is represented through the corresponding packages and the connectivity behaviour is represented through Devices such as the Robot Controller and the PLC which are special classes of Wireless Device containing all of the structure and behavior of the wireless device. Finally, an often overlooked component of any industrial wireless deployment is the spectrum monitoring system represented by the SMS Agent. Blocks in the model communicate through ports such as the *ant* port which represents the antenna or waveguide interface. Composition is further implied by the parts, constraints, and parameters associated with each block. These are listed within the compartments of each block.

5 Detailed Model Decomposition

In this section, we describe in detail the decomposition of the model packages. The decomposition of each package includes the properties and the components of the package where the relation between the package and physical industrial work-cells is illustrated. Moreover, some of the packages may have various types with different properties and hence sub-packages are defined for these packages. This section also includes a general explanation of the packages rules in the work-cell and the behavioral interactions between the packages.

5.1 General Package

The General package contains the reusable elements of the model. In particular, the General package contains elements

that are not particular to any one work-cell component but can be reused or applied across several. The concepts of time, clocks, and synchronization are included within General. Moreover, several types of constraints are defined.

5.1.1 Time

Time is an important construct within communication systems as well as industrial control systems. Time is realized as a set of one or more clocks. A work-cell will contain one to several clocks typically embedded within each device to allow those devices to synchronize to a common clock. The local clocks within the work-cell devices will synchronize to a master reference clock and usually one with a high degree of precision, accuracy, and stability. The degree to which the local clocks synchronize to the master will depend on the requirements of the applications that the local clocks serve. Clock synchronization can be costly in power, size, and monetary cost of the devices, but it may be necessary depending on the applications using a clock. Clock performance is a key driver of size and power consumption, and synchronization of clocks across a wireless network can be a challenge and is a highly studied field [27, 44]. Moreover, the Time package includes a constraint, Clock Performance, to represent the production of time and synchronization with a master clock.

5.1.2 Constraints

Constraints provide limitations on the performance of an element within the model. Within General, several constraints are defined which may be applied to any block within the model. These constraints include motion constraints, radio channel constraints, and networking constraints as shown in Fig. 4a-4c.

Motion Constraints When applied, these constraints provide the bounds of dynamical performance. For example, motion constraints determine the positions, velocities, and accelerations on a rigid body. The force vector equations (1) are the general governing dynamic laws of motion as forces on a vector of joints as exerted by the end-effector or set of end-effectors on the environment. The equations constrain the robot to operate according to the laws of physics, where the joint-space inertia matrix, H , is an $n \times n$ symmetric, positive-definite matrix, and q , \dot{q} , and \ddot{q} are vectors of position, velocity, and acceleration, respectively. The variable f_{ext} is the six degrees of freedom (DOF) force acting on the end-effector, and c is the joint-space bias force required to produce a zero sum force on the end-effector [21].

$$\Gamma = H(q)\ddot{q} + c(q, \dot{q}, f_{ext}) \quad (1)$$

where Γ is the vector of forces exerted by the end-effectors.

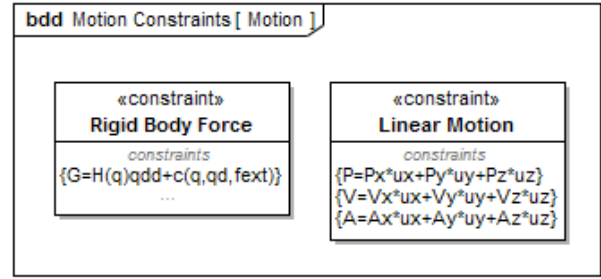

(a) Motion Constraints

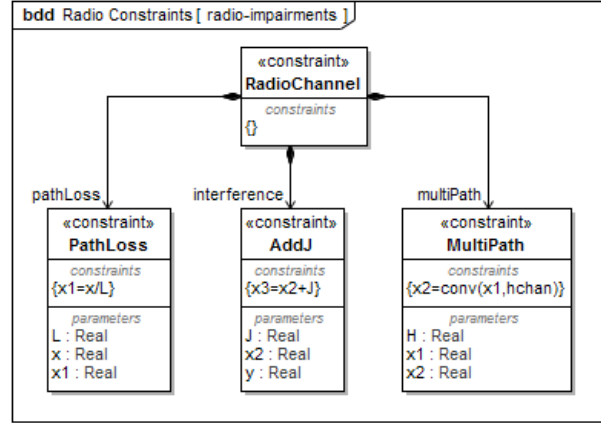

(b) Radio Channel Constraints

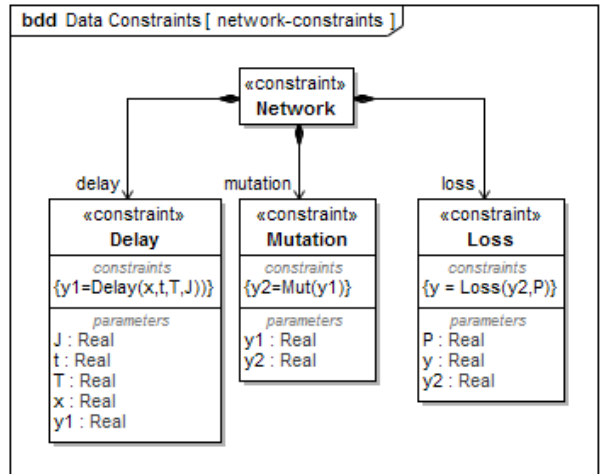

(c) Networking Service Constraints

Fig. 4 Generalized network constraints consisting of rigid body motion (a), the radio channel (b) and the network services (c).

This system of equations is controlled using a combination of digital feed-forward and feedback compensation in which the communication mechanism of the robot states directly impacts the controller's effectiveness. Joint control via a wireless network connection is typically avoided; however, monitoring of the linear and angular forces represented by f_{ext} as sensed by a 6-DOF force-torque (FT) wireless sensor can be advantageous for many industrial applications.

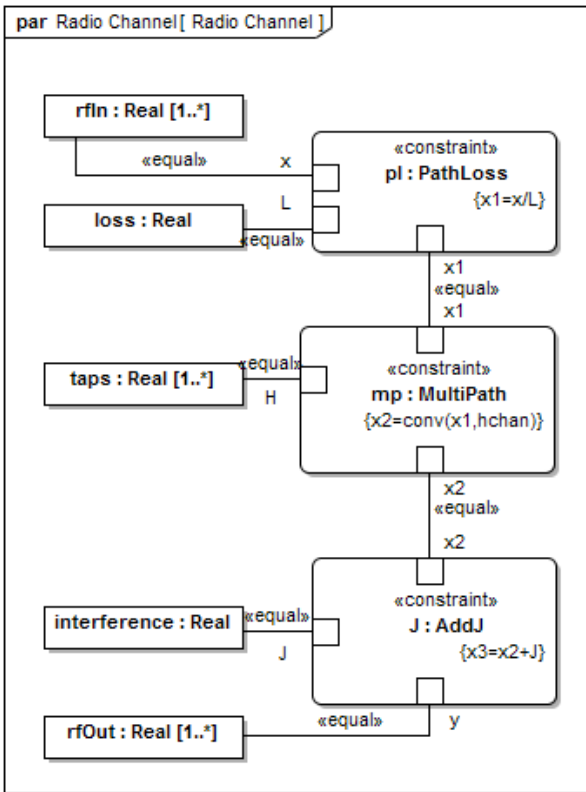

Fig. 5 SysML parametric diagram of the radio channel constraints of the industrial wireless network.

As such, the performance of the wireless connection between a FT sensor and the controller can be a limiting factor in the performance of force-sensitive applications. Such a constraint may be applied to robot manipulators as defined in Section 5.5.

Radio Channel Constraint The radio channel constraint limits wireless information flow to the laws of propagation which includes path loss, reflection, diffraction, and interference. By applying this constraint to Wireless Devices described in Section 5.4.2, such devices experience the effects of a lossy communication medium. The radio channel when applied to a wireless communication link within the work-cell manifests itself in accordance of the illustration of Fig. 5. The parametric equations for the radio channel include path loss, multi-path, and interference. Path loss is generically modeled as the input signal divided by the bulk power loss in the channel. Path loss is often characterized as a two-piece linear function of distance [11]. Multi-path is modeled as convolution of the transmitted radio signal with a linear time-varying impulse response characterizing the electromagnetic propagation between transmitter and receiver antenna systems. Interference is then modeled as an additive component with power, bandwidth, and probability of excitation.

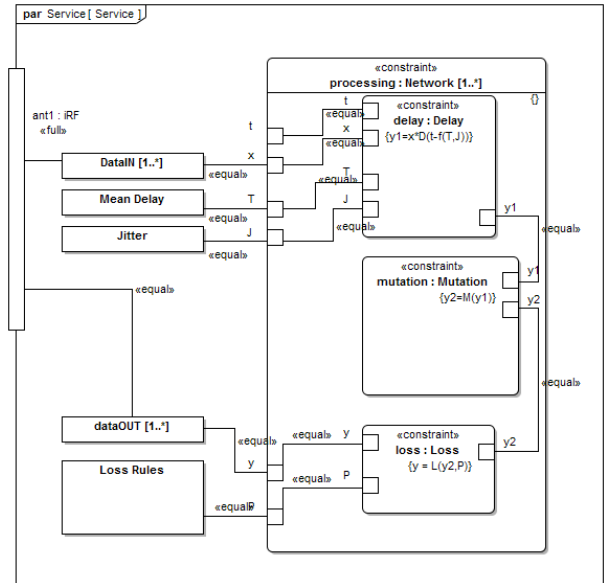

Fig. 6 SysML parametric diagram of the data constraints applied to the industrial wireless network.

Data Constraints Delay, mutation, and loss of information within the industrial wireless network are encapsulated by the Network constraints block. The Network constraint is applied to wireless devices within the network and represents the impacts of the radio channel and network components and protocols. These constraints are illustrated in a parametric diagram of Fig. 6 in which the rules for delay, mutation, and loss are applied to a service of an industrial wireless network within a work-cell. As with any constraint, the rules for data loss may be modeled as equations, pseudocode, or executable computer code such as MATLAB script or C. These rules decide if information is lost due to delay or mutation. While it is easy to understand how mutation leads to loss through a mechanism such as a checksum, unacceptable delay can also lead to loss of data.

Delay is simply a function of time, the physical environment of the factory work-cell, and state of the network at time, t . Many features of the network and the physical environment will have an impact on the output of the delay equation and will include data transmission duration, radio wave propagation delay, signal-to-noise, protocol for reliability, routing, internal queuing, and processing. A generalized equation for information delay by the wireless network is given as the sum of processing delay, queuing delay, transmission delay, and propagation delay. Subsequently, information loss is modeled as a set of rules governed by the attributes of the network infrastructure, transport medium, and protocols shown in (2). These rules may include thresholds for unacceptable delay and the ability of the network to correct for data mutation or loss in the physical channel (i.e. the air interface).

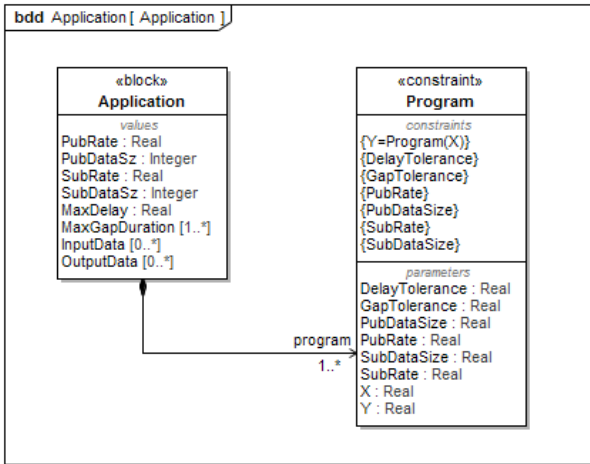

Fig. 7 Block definition diagram of the Application.

$$\mathcal{Y}(t, \mathcal{X}, \mathcal{N}) = \begin{cases} \mathcal{X} & \text{if } \mathcal{X} \vdash \mathcal{L}(t, \mathcal{X}, \mathcal{N}) \\ \emptyset & \text{otherwise} \end{cases} \quad (2)$$

where \mathcal{X} and \mathcal{Y} are blocks of data traversing the network and \mathcal{N} is the state of the network at time, t . We model the loss constraints as a general set of rules, \mathcal{L} , taking into account that each network system will have a different set of configuration attributes and protocols. The rules will therefore change for each operational system and the networks used. When the rules for loss are applied, the output of the network, \mathcal{Y} , becomes the input to the network, \mathcal{X} , when \mathcal{X} satisfies $\mathcal{L}(t, \mathcal{X}, \mathcal{N})$.

5.2 Application

Applications, commonly implemented as software and firmware, represent the intelligence of devices. The application defines the behavior and the information flow requirements of the work-cell [33, 54, 57]. As defined in the model, without Applications implemented in software, firmware, or hardware, the work-cell devices would not function. The definition of the Application block is shown in Fig. 7. The Application block is constrained by the Program constraint which defines the logic of the program, its expected data flow input rates, and its tolerances to delay and information loss. Devices host multiple applications each with a unique set of constraint properties. It is essential when constructing a work-cell model that each application is identified and modeled appropriately. An example of an Application is a collision detection system within a robot controller. Table 1 illustrates sample parameters used in the collision detector Application.

Specification of Application constraints provides a clear picture of the requirements of the factory automation system

Table 1 Constraints Pertaining to a Collision Detector

Constraint Property	Typical Value
Input Payload Size	1 KB
Subscription rate	125 Hz
Maximum Delay Tolerance	47 μ s
Maximum Loss Duration	275 ms

which can be projected on the wireless network. Through this process, it is possible to determine such requirements as scalability, throughput, reliability, and latency of the supporting network services modeled as radio and data constraints in Section 5.1.2. Indeed, as the manufacturing system becomes more complex and wireless becomes essential to communication, the projection of manufacturing requirements onto the wireless communication system becomes less clear. Frequency planning, transmission scheduling, and error correction schemes become less obvious, and considerations of power, reliability, latency, and scale become optimization trade-offs. Such analyses are not within the scope of this paper but are important considerations for future research of manufacturing systems. As such, the architectural elements and information flows exposed by an abstract model are a necessary first step.

5.3 Industrial Wireless Network

Central to the automation system is connectivity among devices and controllers [15]. More specifically, modern automation systems often employ networks to conduct inter-device communication [7]. The term *inter-device* is appropriate as the Device block serves as the basis for all other components that communicate through the network. Our model of the IWN is composed simply as a radio channel, a set of services, and a set of clocks as shown in Fig. 8a. This simplification of the model is necessary to allow the users of the model to provide as much or as little detail of the implementations of the radio channel and underlying services as required for their implementations.

Connectivity of a constructed IWN is shown in Fig. 8b. An IWN is internally modeled such that information flows as radio frequency (RF) energy through the *ant* port. A radio channel is applied, theoretically for each pairwise link, and the modified signal is passed to the services for processing. Network processing is modeled by the properties of network constraints as defined in Section 5.1.2. Once processed by network services, information is routed back through the radio channel through the *ant* port to other Devices connected to the IWN. Moreover, the Service block includes a parametric model as shown in Fig. 8. This IBD with exposed parametrics exemplifies the inclusion parameters such as information delay and loss caused by the IWN, but it also exemplifies the impact of protocols and infrastructure

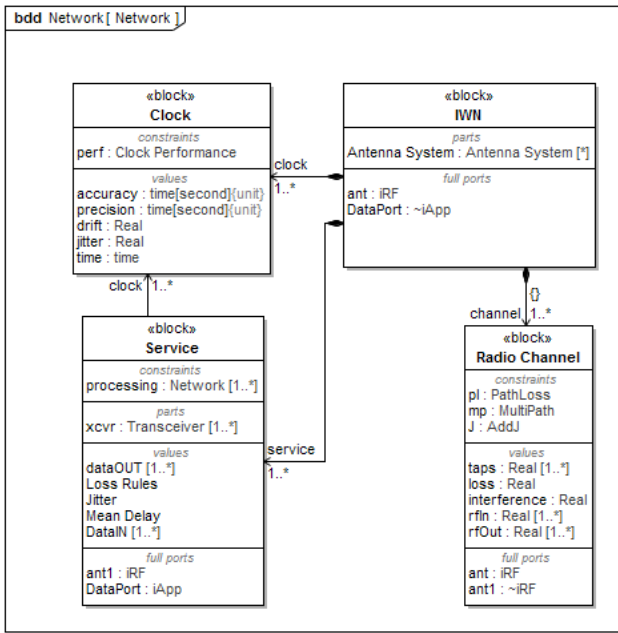

(a)

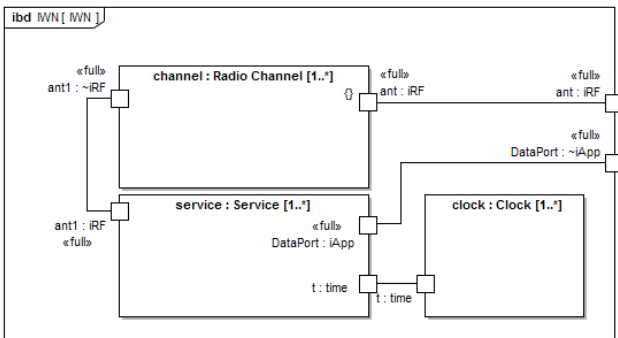

(b)

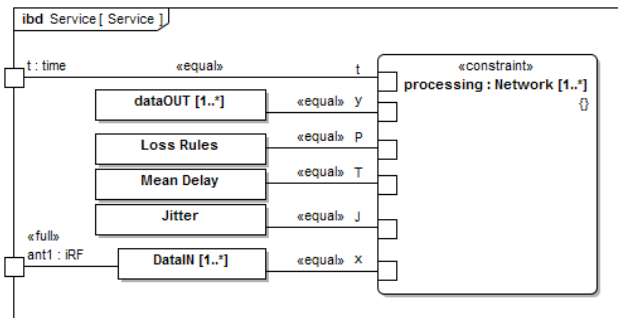

(c)

Fig. 8 The BDD (a) and IBD (b) of the industrial wireless network with parametric IBD (c) of the Services block.

(throughput, memory, etc.) within the network. These effects are modeled as rules of loss shown in (2).

5.4 Devices

5.4.1 Device

A Device, defined in Fig. 9, is generic construct representing an element within the work-cell with processing, memory, and storage capability. Devices have the capability to run applications as defined in Section 5.2. Devices are subclassed into Sensor and Actuator devices which generically refer to any type of sensor or actuator, and, in particular, the wired variety. The Device is further sub-classed to the Wireless Device which is the central theme of our analysis. Derived from the Wired Device are the Wireless Sensor and Wireless Actuator as well as the Controller. The Controller represents the base class for deriving work-cell devices such as the PLC and the Robot Controller, sections 5.6 and 5.5, respectively, and provides support for external input-output (IO).

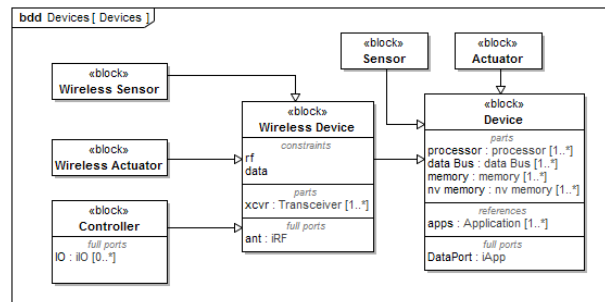

Fig. 9 SysML block definition diagram of wireless devices within the factory work-cell.

5.4.2 Wireless Devices

A Wireless Device is a subclass of Device that contains the various components necessary for untethered communication. These devices then communicate with each other through one or more industrial wireless networks (IWNs) which contains antenna systems, transceivers, protocols, and network services. The relationships and composition of the Wireless Device are illustrated in Fig. 10. As shown, the wireless device is composed of at least one transceiver and each transceiver is composed of at least one antenna system which is composed of at least one antenna element. The antenna system is constrained by its gain profile.

5.4.3 Test Device

The Test Device is a subclass of Device that represents devices used for calibration or ground truth testing of proper-

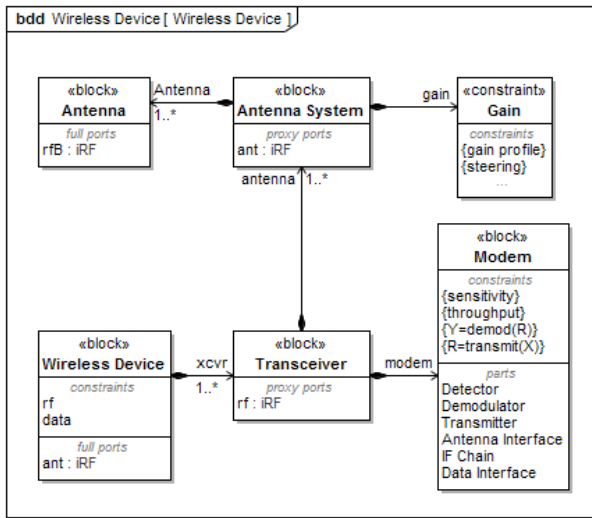

(a) Block definition diagram of the Wireless Device

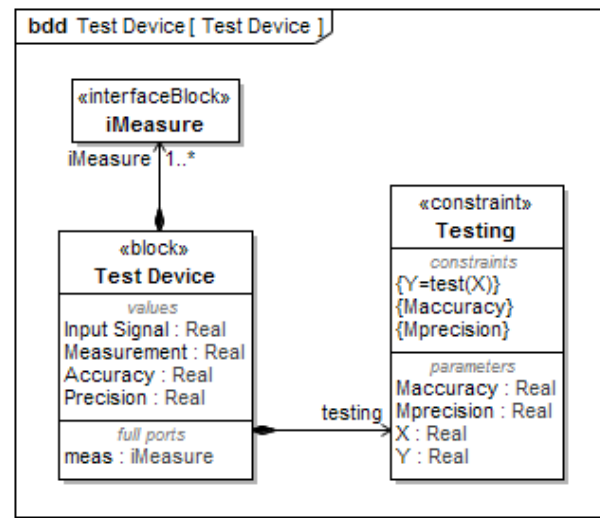

(a) Block definition diagram of the Test Device

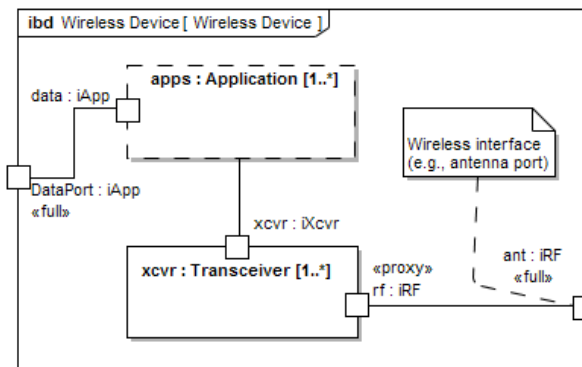

(b) Internal block diagram of the Wireless Device

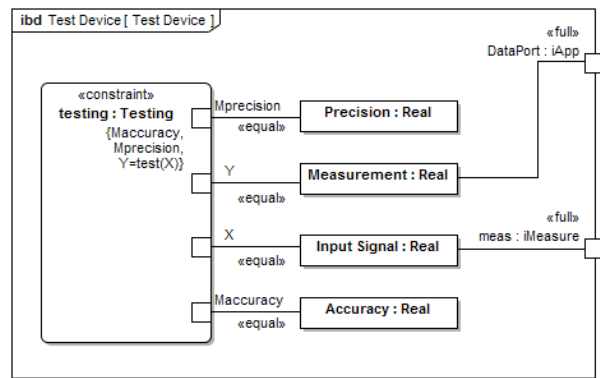

(b) Internal block diagram of the Test Device

Fig. 10 Block definition diagram (a) and the internal block diagram (b) of Wireless Device.

Fig. 11 Block definition diagram (a) and the internal block diagram (b) of Test Device.

ties of a work-cell. The block definition and internal configuration are illustrated in Fig. 11. A Test Device is constrained by its accuracy and precision as well as the algorithm for controlling measurement. An example of a test device is a calibrated force sensor that may be used as comparison to a 6-DOF wireless sensor mounted on the wrist of a robot arm as shown in the top left of Fig. 15. Test devices are useful and necessary elements of the wireless testbed to establish accurate and repeatable ground truth measurements. For example, a stationary precision force sensor may be used to establish a ground truth force value, and a high-accuracy vision tracking system is used for truth in position. Test devices are modeled such that measurements may traverse the operational wireless network or a stand-alone wired interface.

5.5 Robotics

The robotics package contains elements specific to robot systems. Robot systems are composed of at least one robot controller associated with one or more robots, as shown in Fig. 12a. In manufacturing, robots interact with their surrounding to accomplish assigned tasks such as tending machinery, moving materials, welding, and inspecting. Robot controllers provide support for external IO devices. In addition, modern robot controllers will support a variety of open and proprietary network protocols allowing for interaction with other actors in the work-cell. The robot controller's main task is control of the rigid body dynamics of the robots which is usually conducted via real-time communication over a high-throughput serial field-bus. While joint control is conducted using wires, the robot controller is responsible for other tasks requiring reliable, low-latency communication in which wireless may serve a role. These

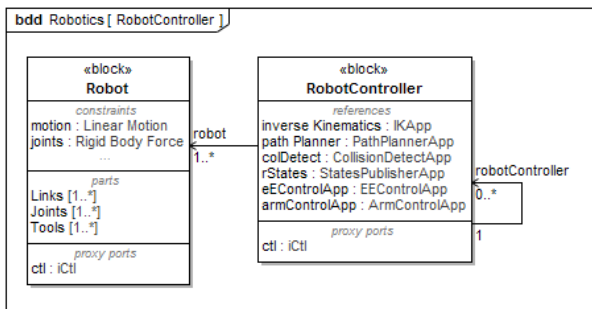

(a) Block definition diagram of the Robot Controller

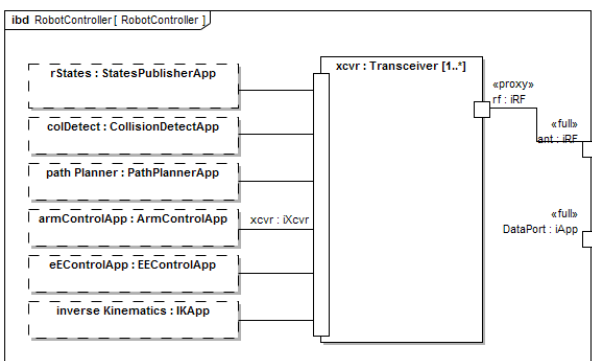

(b) Internal block diagram of the Robot Controller

Fig. 12 The BDD (a), IBD (b) of the Robot Controller.

tasks are captured in the model as applications (Fig. 12b) and explained as follows.

Robot States Publisher Transmission of robot states to external actors such as other robot controllers, supervisors, and safety systems.

Arm Controller Also known as manipulator control, serves to accept position commands as Cartesian or joint space trajectories and waypoints from other actors within the work-cell.

End Effector Control Command and control of the robot end-effector such as a gripper or sensor. The end-effector may be equipped with a high-throughput wireless sensor necessitating reliable communication.

Inverse Kinematics Converts Cartesian coordinates of the end-effector into joint positions.

Path Planner Determines the optimal geometrical trajectory to achieve a final pose given knowledge of self-collision and real-time knowledge of the surround environment. Path planning is a sophisticated part of a robot system and may be allocated to an external system depending on throughput and latency requirements.

Collision Detector This application monitors the states of other actors and obstructions within the work-cell. If possibility of collision is detected, the collision detector takes action.

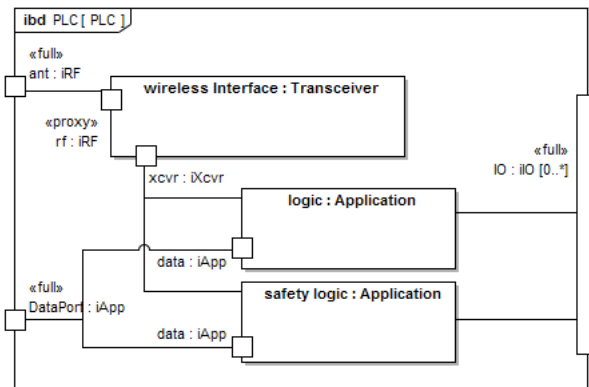

Fig. 13 The IBD of the PLC showing composition and connectivity of the control logic and safety logic Application instantiations to the Transceiver interface.

These applications within the robotic work-cell define many information flows requiring careful analysis to achieve reliability and latency necessary for the safety and control of the manufacturing process. Information flows are identified in Section 6.

5.6 PLC

The PLC is a specialized class of Controller. PLCs were originally developed to mirror relay circuits in software; however, the modern PLC is much more advanced and is usually equipped with multiple processors, a real-time operating system (OS), and capabilities to support various types of industrial IO devices. In addition, modern PLCs (also called automation servers) include both a general purpose OS with a real-time kernel and multiple network interfaces. Many network-routable protocols are also supported. With the addition of wireless protocols, PLCs now have the ability to support IO devices connected remotely without wires. Supervision of untethered robots is also possible using PLCs. The PLC is modeled as a Controller device with the work-cell model. Shown in Fig. 13, the PLC is modeled as a wireless device with transceiver, logic application, and safety applications. More sophisticated PLCs may be modeled by extending the PLC block. As applications, the logic and safety functions are constrained by application constraints. Finally, as Controller devices, PLCs are modeled with an IO port, thus IO can be connected to the PLC by wires or by wireless network connection.

5.7 Safety

In a work-cell with interacting humans and robots, functional safety requirements are typically strict by specifying the rules related to four main safety criteria, namely, monitored stops, controlled speeds, separation distances, and power

and force limits in order to prevent injury for humans and damage for equipment. The wireless safety package is composed of a safety controller and safety devices. Traditionally, the safety requirements of the work-cell is fixed and managed by the safety controller which receives safety-related measurements and takes the corresponding actions. Alternatively, the safety controller may be connected to the PLC where the current work-cell activities are supervised. The PLC will determine the required safety rating and the safety controller behaves accordingly. The dedicated safety controller is needed to achieve the required high reliability and low latency safety requirements and it can be a general PLC with safety modules.

The safety devices include non-safety-rated devices such as the various work-cell sensors and actuators and safety-rated input and output devices. Safety control input devices include Emergency-stop and enabling buttons while output devices include relays and switches for various work-cell equipment. The use of wireless in safety control loops allows installing a larger number of sensing devices including vision systems to monitor the human and robots activities, velocity and proximity sensors, and machine status sensors. Moreover, wireless allows to have mobile control panels where workers can activate a safety device at any time and location within the work-cell.

5.8 Vision

The vision system considered in this subsection is the one used for work-cell monitoring and general object detection. It does not cover the machine-embedded vision systems which can be used for inspection and characterization of objects such as the shape, color, texture, or size of processed materials. The data collected by the work-cell vision system can be used for parts and mobile robots tracking, collision avoidance, object detection, security identification systems, and augmented reality devices and systems. The vision system communicates with the supervisory control, robotic controller, and the safety system to provide the work-cell state which contains the positions of various equipment, robots, and humans.

The vision system is composed of optical devices, vision processing unit, and interfaces to various work-cell systems. The optical devices are the cameras for capturing images at high enough speed to track and detect various objects. These cameras have wireless network interfaces to be connected to the vision processing unit to allow collaborative processing of the captured images and obtaining precise work-cell state. The vision processing unit performs data acquisition from the distributed optical devices and feature extraction to detect and track the positions of various entities in the work-cell.

The vision system communicates the corresponding data to the supervisory control, robotic control, and the safety system for decision making based on the captured work-cell state. The supervisory controller uses vision system data for robots and workers localization, parts detection and identification, and schedules tasks using this information. The robotics controller uses these data for motion control, path planning, and collision detection. Finally, the safety controller uses these data for safety requirements implementation such as enforcing safety stops, controlling the speeds of moving objects, and limiting power and forces of various work-cell components.

5.9 Spectrum Monitoring System

A spectrum monitoring system (SMS) is an often overlooked yet valuable part of the wireless factory work-cell with requirements specified in [10]. The SMS is modeled as an atomic agent within the work-cell. The SMS Agent is one component in a larger enterprise-level spectrum monitoring deployment. The SMS agent shown in Fig. 14 includes a transceiver, an event detector, and a reporting agent. The transceiver can be implemented as an RF-to-baseband converter. The detector application is responsible for detection and estimation of anomalous spectral events and may employ machine learning to accurately detect anomalies and report localized spectral events.

The reporter application collects, filters, and reports event information to a central management console. SMS reports support identification of long-term patterns such as growth trends in particular wireless bands. Since the SMS Agent is part of a larger network of spectrum monitoring, it is presumed that reports are wirelessly transmitted back to the enterprise management console. These reporting events use bandwidth otherwise used for the factory operation, thus reports must be made concise and infrequent. This implies substantial filtering and intelligence in the local SMS agents. This may provide opportunities for research.

Detection events may be routed to the local supervisor, robot controller, and safety system. By leveraging spectral awareness, work-cells can be made safer and more reliable. As SMS are not yet widespread in industrial applications; thus, standardized protocols are needed for reporting and integration with automation systems.

5.10 Human

Humans can exist in a modern work-cell for short or long periods of time depending on the required task. Two categories of human-related aspects are captured in the work-cell model. First, the human existence in the work-cell leads to detection and identification of the corresponding worker

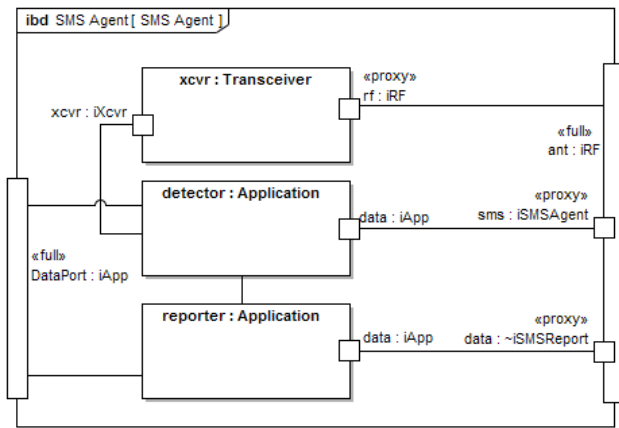

Fig. 14 Spectrum monitoring agent composed of transceiver, detection application, and reporting application.

for both safety and security. Also, human motion within the work-cell requires position tracking for environment monitoring and spectrum monitoring due to radio frequency channel variations with human movements. The second category includes the human interfaces with the work-cell process that include portable control devices, wearable sensors, and workers communication devices to get task commands. Moreover, depending on the process constraint, personal devices of workers may interfere with the work-cell communications if allowed.

6 Results of a Work-cell Case Study

In this section we present a case study of a work-cell which includes a force-torque limiter robot application and a two-robot collaborative pick and place operation. The model for this system is depicted in Fig. 15. The number and type of wireless information flows will depend on the configuration of the work, the number of applications, and the places where wireless is applied. For this case study, the force limiter section is composed of a robot controller, a robot, and an FT sensor. A PLC is used for work-cell supervision, and a test device is deployed for ground truth measurement. An SMS agent monitors the electromagnetic spectrum. A Radio Emitter is included to model the transmission of interference. An IEEE 802.11n network is represented in the model by an IWN block. Properties of the radio channel and services of the communication system are therefore represented. Similarly, another example is implemented in [9] for a pick-and-place scenario where the model is composed of two robots, a PLC, an IWN, and an SMS Agent in addition to proximity sensors and an IEEE 802.11ax network.

Referring to these examples, typical information flows are easily identified as connections between Wireless Device blocks and the antenna port, *ant*, of the IWN. Recall

that the IWN includes radio channel and services offered by the network itself. Therefore, all wireless information flows will traverse the IWN through the *ant* port. Applications are implied and produce and consume the information according to associated constraint properties. Information flows are generated by the interactions between actors and include the following:

Robot States The geometry states of the robot such as position, velocity, and acceleration of each joint or end-effector. Robot states may include Cartesian or joint space readings depending on the need of other applications or the capabilities of publisher. Robot states are usually transmitted at 30 Hz or faster [45].

Force Sensor Readings The readings from a sensor mounted on the wrist of each robot arm. These readings are typically in the format of wrenches (linear and angular forces) and are transmitted at rates from 15 Hz for monitoring applications up to 500 Hz for force limiting and control applications [50]. Other sensors may produce data in the system such as proximity sensors which can generate data in the range of 1-50 Hz [18] and Tactile sensors which can have information flow rates faster than 1000 Hz [23].

Machine Health Monitoring Readings from sensors mounted within machinery such as mills, routers, and lathes used to sense and predict deviations of mechanical components from design tolerances. Readings for prognostics and health monitoring are often aggregated at the source with statistical metrics being communicated to a factory enterprise application; however, non-aggregated readings may also be transmitted to a remote signal analyzer. Health monitoring sensors measure temperature, vibration, acceleration, inclination, position, and rates of change of angles. Information flows from a single aggregation point may reach 200 kB/s on average for a 6-DOF sensor apparatus described in [56]. While the outputs of health monitoring sensors are usually wired into a local aggregation devices, it is desirable to transmit these readings to an on-line optimizer or PLC within the work-cell [65].

IO States and Supervisory Messages These contain both the boolean-valued readings and commands from sensors, and task orders in the form of short commands and lists of instructions which can originate from any supervisor within the network such as a PLC or other controller. Sensor readings (inputs) and actuation commands (outputs) are transmitted in periodically or pseudo-randomly at rates indicative of movements of machinery and materials through the manufacturing process. Typical analog and boolean IO states range from to 10 Hz to 100 Hz depending on the manufacturing process [4].

SMS Events The SMS agent will communicate state information and directives to controllers within the work-cell. These messages allow the automation system to react

7 Discussion and Conclusions

A model was developed using SysML. The developed model is constructed of the elements necessary to construct useful representations of factory work-cells in which wireless networks are used to transport information necessary for automated control system operation. Reusable, derivable elements are developed and then extended to represent the constructs of the work-cell such as robot control, supervisory control, vision, safety, and spectrum monitoring. An industrial wireless network is then developed and constraints of the radio channel and network services are formalized. Using the architectural model, information flows are explored and incorporated within.

It is important to mention that this model includes an often overlooked component of any industrial wireless deployment which is the spectrum monitoring system and also considers the human-robot and robot-robot interactions in industrial environments. The current model includes various systems constraints including motion constraints, radio channel constraints, and networking constraints. The parametric constraints are provided as examples and can be replaced with executable computer code thereby making the model useful for simulation depending on the modeling tool selected. Furthermore, the applications within the robotic work-cell define many information flows requiring careful analysis to achieve reliability and latency necessary for the safety and control of the manufacturing process.

With increased dependency on wireless communications for more complex manufacturing systems, the projection of manufacturing requirements onto the wireless communication system becomes less obvious. Such analysis of this projection is essential for future research of manufacturing systems. As such, the architectural elements and information flows exposed by an abstract model are a necessary first step. Our model in its current state of development is comprehensive enough to support architectural and ontological analyses of the factory work-cell. As such, information about the relationships between components of a work-cell and attributes related to the wireless network may be discovered. Therefore, our model serves as a foundation for future systems engineering analyses. Moreover, our model may be used as a tool for academic and industry exploration of wireless testbed development. We make the model openly available through GitHub at [9].

Disclaimer

Certain commercial equipment, instruments, or materials are identified in this paper in order to specify the experimental procedure adequately. Such identification is not intended to imply recommendation or endorsement by the National Institute of Standards and Technology, nor is it intended to im-

ply that the materials or equipment identified are necessarily the best available for the purpose.

References

1. Electromagnetic Compatibility And Radio Spectrum Matters (Erm); System Reference Document; Short Range Devices (Srd); Part 2: Technical Characteristics For Srd Equipment For Wireless Industrial Applications Using Technologies Different From Ultra-wide Ban (2011). URL https://www.etsi.org/deliver/etsi_tr/102800_102899/10288902/01_01_01_60/tr_10288902v010101p.pdf
2. 3GPP: Service requirements for the 5G system; Stage 1 (Release 16). 3GPP (2018). V16.3.0
3. Alvarez, M.L., Estévez, E., Sarachaga, I., Burgos, A., Marcos, M.: A novel approach for supporting the development cycle of automation systems. *The International Journal of Advanced Manufacturing Technology* **68**(1-4), 711–725 (2013). DOI 10.1007/s00170-013-4793-4. URL <http://link.springer.com/10.1007/s00170-013-4793-4>
4. Automation), B.: Ethercat io terminals, digital input eLxxx/esLxxx. URL <http://www.beckhoff.com/Twincat3/>
5. (AutonomouStuff): Lidar specification comparison chart. URL https://autonomoustuff.com/wp-content/uploads/2018/04/LiDAR_Comparison.pdf
6. Barnard Feeney, A., Frechette, S., Srinivasan, V.: *Cyber-Physical Systems Engineering for Manufacturing*, pp. 81–110. Springer International Publishing, Cham (2017). DOI 10.1007/978-3-319-42559-7_4. URL https://doi.org/10.1007/978-3-319-42559-7_4
7. Bello, L.L., kerberg, J., Gidlund, M., Uhlemann, E.: Guest editorial special section on new perspectives on wireless communications in automation: From industrial monitoring and control to cyber-physical systems. *IEEE Transactions on Industrial Informatics* **13**(3), 1393–1397 (2017). DOI 10.1109/TII.2017.2695585
8. (Bosch): MIC Series 612 Thermal Camera. URL https://us.boschsecurity.com/en/products/videosystems/analogcameras/ptzcameras/micseries612thermalcamera/micseries612thermalcamera{_}20139
9. Candell, R.: Model of the Wireless Factory Work-cell using the Systems Modeling Language (2018). DOI 10.18434/T4/1502475. URL <https://github.com/usnistgov/wireless-factory-sysml>
10. Candell, R., Aksu, M.: Requirements for spectrum monitoring in industrial environments. Tech. rep., National Institute of Standards and Technology, Gaithersburg, MD (2017). DOI 10.6028/NIST.IR.8195. URL <https://nvlpubs.nist.gov/nistpubs/ir/2017/NIST.IR.8195.pdf>
11. Candell, R., Remley, C., Quimby, J., Novotny, D., Curtin, A., Papazian, P., Koepke, G., Diener, J., Kashef, M.: Industrial wireless systems: Radio propagation measurements. Tech. rep., National Institute of Standards and Technology, Gaithersburg, MD (2017). URL <http://nvlpubs.nist.gov/nistpubs/TechnicalNotes/NIST.TN.1951.pdf>
12. Carpanzano, E., Jovane, F.: Advanced automation solutions for future adaptive factories. *CIRP Annals* **56**(1), 435 – 438 (2007). DOI <https://doi.org/10.1016/j.cirp.2007.05.104>. URL <http://www.sciencedirect.com/science/article/pii/S0007850607001059>
13. Chang, Q., Biller, S., Xiao, G., Liu, J.: Transient analysis of downtimes and bottleneck dynamics in serial manufacturing systems **132** (2010)

14. Chen, I.M.: Rapid response manufacturing through a rapidly reconfigurable robotic workcell. *Robotics and Computer-Integrated Manufacturing* **17**(3), 199 – 213 (2001). DOI [https://doi.org/10.1016/S0736-5845\(00\)00028-4](https://doi.org/10.1016/S0736-5845(00)00028-4). URL <http://www.sciencedirect.com/science/article/pii/S0736584500000284>
15. Chen, J., Cao, X., Cheng, P., Xiao, Y., Sun, Y.: Distributed collaborative control for industrial automation with wireless sensor and actuator networks. *IEEE Transactions on Industrial Electronics* **57**(12), 4219–4230 (2010). DOI 10.1109/TIE.2010.2043038
16. Colledani, M., Gershwin, S.B.: A decomposition method for approximate evaluation of continuous flow multi-stage lines with general markovian machines. *Annals of Operations Research* **209**(1), 5–40 (2013). DOI 10.1007/s10479-011-0961-9. URL <https://doi.org/10.1007/s10479-011-0961-9>
17. Cuevas-Ruiz, J.L., Garcia-Alba-Idunate, P.: Spectrum monitoring. an approach based on people-centric sensing (smopec) (2015). URL https://www.thinkmind.org/index.php?view=article&articleid=centric_2015_4_20_30057
18. Direct, A.: C5 series stainless steel photoelectric sensors. URL <https://cdn.automationdirect.com/static/specs/pe5mmc5.pdf>
19. Duan, F., Tan, J.T.C., Arai, T.: Using motion capture data to regenerate operator's motions in a simulator in real time. In: 2008 IEEE International Conference on Robotics and Biomimetics, pp. 102–107 (2009). DOI 10.1109/ROBIO.2009.4912987
20. Durugbo, C., Tiwari, A., Alcock, J.R.: A review of information flow diagrammatic models for productservice systems. *The International Journal of Advanced Manufacturing Technology* **52**(9-12), 1193–1208 (2011). DOI 10.1007/s00170-010-2765-5. URL <http://link.springer.com/10.1007/s00170-010-2765-5>
21. Featherstone, R.: Robot dynamics. *Scholarpedia* **2**(10), 3829 (2007). DOI 10.4249/scholarpedia.3829. Revision #91723
22. Ferreira, P., Reyes, V., Mestre, J.: Control architecture for a supervised industrial robotic workcell integration. In: ETFA2011, pp. 1–4 (2011). DOI 10.1109/ETFA.2011.6059204
23. Fettweis, G.P.: The tactile internet: Applications and challenges. *IEEE Vehicular Technology Magazine* **9**(1), 64–70 (2014). DOI 10.1109/MVT.2013.2295069
24. Friedenthal, S., Moore, A., Steiner, R.: *A Practical Guide to SysML*, third edn. Boston (2015)
25. Fulea, M., Popescu, S., Brad, E., Mocan, B., Murar, M.: A literature survey on reconfigurable industrial robotic work cells **762**, 233–241 (2015)
26. Gaspar, T., Ridge, B., Bevec, R., Bem, M., Kova, I., Ude, A., Gosar, .: Rapid hardware and software reconfiguration in a robotic workcell. In: 2017 18th International Conference on Advanced Robotics (ICAR), pp. 229–236 (2017). DOI 10.1109/ICAR.2017.8023523
27. Geetha, D.D., Tabassum, N.: A survey on clock synchronization protocols in wireless sensor networks. In: 2017 International Conference On Smart Technologies For Smart Nation (SmartTech-Con), pp. 504–509. IEEE (2017). DOI 10.1109/SmartTechCon.2017.8358424. URL <https://ieeexplore.ieee.org/document/8358424/>
28. Gershwin, S.B., Werner, L.M.: An approximate analytical method for evaluating the performance of closed-loop flow systems with unreliable machines and finite buffers. *International Journal of Production Research* **45**(14), 3085–3111 (2007). DOI 10.1080/00207540500385980. URL <https://doi.org/10.1080/00207540500385980>
29. Grau, A., Indri, M., Bello, L.L., Sauter, T.: Industrial robotics in factory automation: From the early stage to the internet of things. In: IECON 2017 - 43rd Annual Conference of the IEEE Industrial Electronics Society, pp. 6159–6164 (2017). DOI 10.1109/IECON.2017.8217070
30. Hanley, B., Tucker, C., Bissas, A.: Differences between motion capture and video analysis systems in calculating knee angles in elite-standard race walking. *J. Sports Sci.* **36**(11), 1250–1255 (2018). DOI 10.1080/02640414.2017.1372928
31. Hart, L.E.: *Introduction to model-based system engineering (mbse) and sysml* (2015). URL <https://www.incose.org/docs/default-source/delaware-valley/mbse-overview-incose-30-july-2015.pdf>
32. Huang, V.K.L., Pang, Z., Chen, C.A., Tsang, K.F.: New trends in the practical deployment of industrial wireless: From noncritical to critical use cases. *IEEE Industrial Electronics Magazine* **12**(2), 50–58 (2018). DOI 10.1109/MIE.2018.2825480
33. and J. A. Gaines, Nelson, B.J.: A flexible experimental workcell for efficient and reliable wafer-level 3d micro-assembly. In: Proceedings 2001 ICRA. IEEE International Conference on Robotics and Automation (Cat. No.01CH37164), vol. 1, pp. 133–138 vol.1 (2001). DOI 10.1109/ROBOT.2001.932542
34. Jia, M., Ding, G., Qin, S., Li, R., He, Y.: Research of design and analysis integrated information modeling framework for multibody mechanical system: with its application in the LHD design. *The International Journal of Advanced Manufacturing Technology* **66**(9-12), 2107–2122 (2013). DOI 10.1007/s00170-012-4485-5. URL <http://link.springer.com/10.1007/s00170-012-4485-5>
35. Kagermann, H., Wahlster, W., Helbig, J.: Recommendations for implementing the strategic initiative industrie 4.0 – securing the future of german manufacturing industry. Final report of the industrie 4.0 working group, acatech – National Academy of Science and Engineering, München (2013). URL http://forschungsunion.de/pdf/industrie_4_0_final_report.pdf
36. Knepper, R.A., Layton, T., Romanishin, J., Rus, D.: Ikeabot: An autonomous multi-robot coordinated furniture assembly system. In: 2013 IEEE International Conference on Robotics and Automation, pp. 855–862 (2013). DOI 10.1109/ICRA.2013.6630673
37. Law, A.M., Kelton, D.M.: *Simulation Modeling and Analysis*, 3rd edn. McGraw-Hill Higher Education (1999)
38. Lee, J., Bagheri, B., Kao, H.A.: A cyber-physical systems architecture for industry 4.0-based manufacturing systems. *Manufacturing Letters* **3**, 18 – 23 (2015). DOI <https://doi.org/10.1016/j.mfglet.2014.12.001>. URL <http://www.sciencedirect.com/science/article/pii/S221384631400025X>
39. Leito, P.: Agent-based distributed manufacturing control: A state-of-the-art survey. *Engineering Applications of Artificial Intelligence* **22**(7), 979 – 991 (2009). DOI <https://doi.org/10.1016/j.engappai.2008.09.005>. URL <http://www.sciencedirect.com/science/article/pii/S0952197608001437>. Distributed Control of Production Systems
40. Liu, J., Chang, Q., Xiao, G., Biller, S.: The costs of downtime incidents in serial multistage manufacturing systems. *Journal of Manufacturing Science and Engineering* **134**(2), 021016–021016–10 (2012). DOI 10.1115/1.4005789. URL <http://dx.doi.org/10.1115/1.4005789>
41. Liu, Y., Candell, R., Moayeri, N.: Effects of wireless packet loss in industrial process control systems. *ISA Transactions* **68**, 412 – 424 (2017). DOI <https://doi.org/10.1016/j.isatra.2017.02.005>. URL <http://www.sciencedirect.com/science/article/pii/S0019057817302240>
42. Lüder, A., Estévez, E., Hundt, L., Marcos, M.: Automatic transformation of logic models within engineering of embedded mechanical units. *The International Journal of Advanced Manufacturing Technology* **54**(9-12), 1077–1089 (2011). DOI 10.1007/s00170-010-3010-y. URL <http://link.springer.com/10.1007/s00170-010-3010-y>

43. Lütjen, M., Rippel, D.: GRAMOSA framework for graphical modelling and simulation-based analysis of complex production processes. *The International Journal of Advanced Manufacturing Technology* **81**(1-4), 171–181 (2015). DOI 10.1007/s00170-015-7037-y. URL <http://link.springer.com/10.1007/s00170-015-7037-y>
44. Mahmood, A., Exel, R., Trsek, H., Sauter, T.: Clock Synchronization Over IEEE 802.11A Survey of Methodologies and Protocols. *IEEE Transactions on Industrial Informatics* **13**(2), 907–922 (2017). DOI 10.1109/TII.2016.2629669. URL <http://ieeexplore.ieee.org/document/7782431/>
45. Marvel, J.A., Norcross, R.: Implementing speed and separation monitoring in collaborative robot workcells. *Robotics and Computer-Integrated Manufacturing* **44**, 144 – 155 (2017). DOI <https://doi.org/10.1016/j.rcim.2016.08.001>. URL <http://www.sciencedirect.com/science/article/pii/S0736584516302617>
46. Michalos, G., Makris, S., Tsarouchi, P., Guasch, T., Kontovrakis, D., Chryssolouris, G.: Design considerations for safe human-robot collaborative workplaces. *Procedia CIRP* **37**, 248 – 253 (2015). DOI <https://doi.org/10.1016/j.procir.2015.08.014>. URL <http://www.sciencedirect.com/science/article/pii/S2212827115008550>. CIRPe 2015 - Understanding the life cycle implications of manufacturing
47. Molina, E., Lazaro, O., Sepulcre, M., Gozalvez, J., Passarella, A., Raptis, T.P., Ude, A., Nemec, B., Rooker, M., Kirstein, F., Mooij, E.: The autoware framework and requirements for the cognitive digital automation. In: L.M. Camarinha-Matos, H. Afsarmanesh, R. Fornasiero (eds.) *Collaboration in a Data-Rich World*, pp. 107–117. Springer International Publishing, Cham (2017)
48. (Object Management Group): *OMG Systems Modeling Language* (2017). URL <https://www.omg.org/spec/SysML/1.5>
49. Oliveira, A., Pieri, E.D., Moreno, U.: An open-architecture robot controller applied to interaction tasks. In: E. Hall (ed.) *Advances in Robot Manipulators*, chap. 5. InTech, Rijeka (2010)
50. (OnRobot): Hex-h sensor 2.0 datasheet. URL https://onrobot.com/wp-content/uploads/2018/06/hex-h_sensor_2-0_datasheet_june_2018.pdf
51. Orfanus, D., Indergaard, R., Prytz, G., Wien, T.: Ethercat-based platform for distributed control in high-performance industrial applications. In: 2013 IEEE 18th Conference on Emerging Technologies Factory Automation (ETFA), pp. 1–8 (2013). DOI 10.1109/ETFA.2013.6647972
52. Ou, X., Arinez, J., Chang, Q., Zou, J.: Performance analysis of a composite work cell with a gantry and system reconfiguration. *Journal of Manufacturing Systems* **45**, 212 – 221 (2017). DOI <https://doi.org/10.1016/j.jmsy.2017.09.006>. URL <http://www.sciencedirect.com/science/article/pii/S0278612517301334>
53. Ou, X., Chang, Q., Zou, J., Arinez, J., Xiao, G.: Modeling and performance diagnostics of composite work cells with gantries. *IEEE Transactions on Automation Science and Engineering* **15**(3), 1230–1242 (2018). DOI 10.1109/TASE.2017.2762340
54. Papakostas, N., Michalos, G., Makris, S., Zouzias, D., Chryssolouris, G.: Industrial applications with cooperating robots for the flexible assembly. *International Journal of Computer Integrated Manufacturing* **24**(7), 650–660 (2011). DOI 10.1080/0951192X.2011.570790. URL <https://doi.org/10.1080/0951192X.2011.570790>
55. Pidd, M.: *Systems modelling : theory and practice*. Chichester : Wiley (2004). Formerly CIP
56. Qiao, G., Weiss, B.: Monitoring, Diagnostics, and Prognostics for Robot Tool Center Accuracy Degradation. In: 2018 ASME International Manufacturing Science and Engineering Conference. ASME (2018)
57. Quinn, R.D., Causey, G.C., Merat, F.L., Sargent, D.M., Barendt, N.A., Newman, W.S., Velasco, V.B., Podgurski, A., , and, L.S.S.: Design of an agile manufacturing workcell for light mechanical applications. In: *Proceedings of IEEE International Conference on Robotics and Automation*, vol. 1, pp. 858–863 vol.1 (1996). DOI 10.1109/ROBOT.1996.503880
58. Quinsat, Y., Dubreuil, L., Lartigue, C.: A novel approach for in-situ detection of machining defects. *The International Journal of Advanced Manufacturing Technology* **90**(5-8), 1625–1638 (2017). DOI 10.1007/s00170-016-9478-3. URL <http://link.springer.com/10.1007/s00170-016-9478-3>
59. Sisinni, E., Saifullah, A., Han, S., Jennehag, U., Gidlund, M.: Industrial internet of things: Challenges, opportunities, and directions. *IEEE Transactions on Industrial Informatics* **14**(11), 4724–4734 (2018). DOI 10.1109/TII.2018.2852491
60. Stanford University: Protege, A free, open-source ontology editor and framework for building intelligent systems URL <https://protege.stanford.edu/>
61. Tan, J.T.C., Duan, F., Zhang, Y., Watanabe, K., Kato, R., Arai, T.: Human-robot collaboration in cellular manufacturing: Design and development. In: 2009 IEEE/RSJ International Conference on Intelligent Robots and Systems, pp. 29–34 (2009). DOI 10.1109/IROS.2009.5354155
62. Voas, J.: NIST-SP-800-183 Networks of ‘Things’. Tech. rep., National Institute of Standards and Technologies, Gaithersburg, MD (2016). DOI 10.6028/NIST.SP.800-183. URL <https://nvlpubs.nist.gov/nistpubs/SpecialPublications/NIST.SP.800-183.pdf>
63. W3C: *Web Ontology Language (OWL)* (2012). URL <https://www.w3.org/OWL/>
64. Weiner, M., Jorgovanovic, M., Sahai, A., Nikoli, B.: Design of a low-latency, high-reliability wireless communication system for control applications. In: 2014 IEEE International Conference on Communications (ICC), pp. 3829–3835 (2014). DOI 10.1109/ICC.2014.6883918
65. Weiss, B.A., Helu, M., Vogl, G., Qiao, G.: Use Case Development to Advance Monitoring, Diagnostics, and Prognostics in Manufacturing Operations. *IFAC-PapersOnLine* **49**(31), 13–18 (2016). DOI 10.1016/j.ifacol.2016.12.154. URL <http://linkinghub.elsevier.com/retrieve/pii/S2405896316328257>
66. Xia, B., Xi, L., Zhou, B., Du, S.: An efficient analytical method for performance evaluation of transfer lines with unreliable machines and finite transfer-delay buffers. *International Journal of Production Research* **51**(6), 1799–1819 (2013). DOI 10.1080/00207543.2012.713137. URL <https://doi.org/10.1080/00207543.2012.713137>