

On the Impacts of In-Band LTE Emissions

Aziz Kord and Jason B. Coder
 Communications Technology Laboratory
 National Institute of Standards and Technology
 325 Broadway Boulder, CO 80305
 azizollah.kord@nist.gov; jason.coder@nist.gov

Abstract—With the introduction of low-power Internet of Things (IoT) and Device-to-Device (D2D) communications in the Long Term Evolution (LTE) system protocol, the in-band interference from other User Equipment (UE) with higher-power requires special attention. These higher power devices (e.g., smartphones) may cause in-band interference against the lower power devices. To examine this possibility, we examine the in-band spectra of an LTE UE with four different resource block configurations. The results show that as the number of allocated resource blocks decrease, the amount of ripple or “mirroring” increases within the channel. This mirrored signal may raise the noise floor as observed by lower power devices. In turn, these devices may have to radiate more power to overcome this additional noise. Future work includes a study on the effects of this type of interference on: power, latency of victim UE, as well as how the impact varies with network traffic (e.g., voice, real-time streaming, etc.).

I. INTRODUCTION AND BACKGROUND

Long Term Evolution (LTE) is the next generation of Universal Mobile Telecommunications System (UMTS) protocol for high-speed mobile broadband communication. This paper focuses on the impacts of the physical (PHY) layer LTE signal on other LTE devices operating in the same frequency channel.

LTE makes use of a PHY layer technology known as Orthogonal Frequency-Division Multiplexing (OFDM). In OFDM, the channel is divided into smaller 15 kHz sub-carriers. Each sub-carrier may carry information for control, broadcast, or payload data. The LTE protocol divides its channel into a larger group of 180 kHz frequency chunks, known as resource blocks (RBs). Based on Evolved Node B (eNB) scheduling decisions, one or more RBs may be allocated to each UE. The number of RB allocations and the starting location of these RBs may change during normal operation. This is done based on the UE’s RF condition and its service demand. The eNB scheduler may allocate one or more RBs among UEs in that cell in a single transmit interval.

The OFDM technology, adopted by LTE for its physical layer communications, has been known to the research community for some time. In a communications channel, use of narrow band sub-carriers to reduce the chance of interfering with the whole channel is more efficient. With OFDM, the channel is divided into smaller channels. These smaller channels are orthogonal to each other for ease of detection and aid in reducing interference to each other. The disadvantage of these narrow band sub-carriers is that mirroring of the original

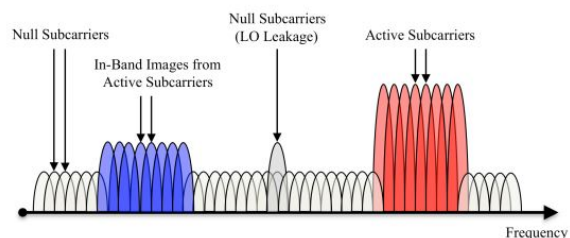

Fig. 1. Quadrature Impairments, as shown in [1]

signal can appear in neighboring sub-carriers. An example of this is shown in Figure 1. There are many reasons that may cause this effect in LTE systems: I/Q gain imbalance, quadrature impairments, etc. [1]

If a UE is assigned RBs on the same sub-carriers that are impacted by mirroring, their noise floor will be higher. This may cause their radiated power to increase as a means of compensating for the decrease in signal to noise ratio (SNR). Additionally, their bit error rate (BER) may increase, and in the worst case scenario, they may be forced to re-transmit data. The magnitude of this impairment will depend on the distance between the victim UE relative to the transmitting UE.

This mirroring impairment is known to the LTE community and was accounted for in the 3GPP technical specifications, TS 36.521 Table 6.5.2.3F.3-1. The limits for in-band emissions are also shown in Table 1. This limit was selected to help protect other high-power UEs in the same channel.

Today, there are many new devices that utilize LTE, e.g. Narrow Band Internet of Things (NB-IoT), Device-to-Device (D2D), etc. These lower-power devices are designed to last for a long time without their batteries being replaced or

TABLE I
 IN-BAND EMISSIONS REQUIREMENTS FROM [1]

Parameter Description	Unit	Limit	
General	dB	$\text{Max}\left\{-25 - 10 * \log_{10} \frac{N_{RB}}{L_{CRBs}}, 20 * \log_{10} EVM - 3 - 5 * \frac{(\Delta_{RB} 1)}{L_{CRBs} * -57\text{dBm}/180\text{KHz} - P_{RB}}\right\}$	
IQ Image	dB	-25	
Carrier Leakage	dBc	-25	Output power >0 dBm
		-20	-30 dBm < Output power < 0 dBm
		-10	-40 dBm < Output power < -30 dBm

recharged. Their data are short and commonly in the form of bursts. Those features make this category of UE more susceptible to interference caused by the mirroring effect than higher powered UEs. As more of these types of devices are deployed in the field, the risk of in-band interference from higher powered devices grows.

II. SETUP AND EQUIPMENT

To illustrate the in-band emissions of a UE allocated a given number of RBs, a high-dynamic range measurement was set up. This setup consists of an eNB emulator, UE, RF pre-selector (low-noise amplifier, filter, and a noise diode for calibration purposes), vector signal analyzer (VSA), and laptop. As the measured UE had no conducted ports available, an RF chamber, receiving antenna, and series of splitters and circulators were employed. The eNB emulator is used to force the UE to radiate its maximum transmission power and to select the location and number of RBs in the channel.

As the UE transmits its data, the uplink and downlink signals are split. The uplink signal is then fed into the RF pre-selector where it is eventually measured by the VSA. Additional details on the pre-selector can be found in [2].

The RF spectrum data was measured by the VSA with an RMS type detector at a resolution bandwidth of 1 MHz. Four different RB configurations (5, 12, 25, and 50) were selected and measured for comparison:

Note that this measurement setup was also used to measure the out-of-band emissions described in [3]. These measurements took place in the AWS-3/Band 66 frequency band. However, the results discussed here are frequency agnostic and should be considered in any band.

III. MEASUREMENT

The power spectra is shown in Figure 3. Data shown have been normalized to the peak signal. As seen in this figure, the ripple increases as the number of RBs decrease. That is, the mirroring effect is strongest in the 5 RB configuration.

The power of the mirrored signals met the 3GPP mask limit but the victim UE(s) operating in these frequencies needs to:

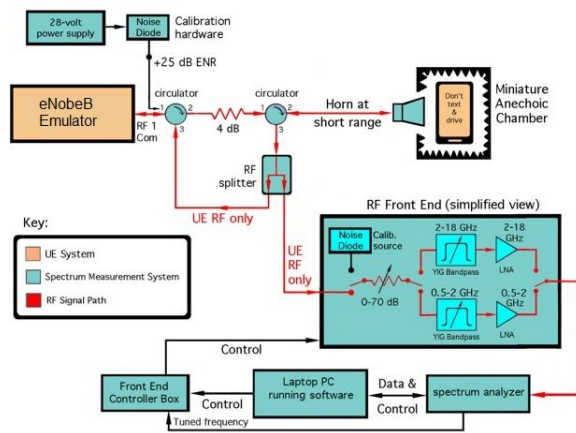

Fig. 2. Test Setup. Adapted from [2].

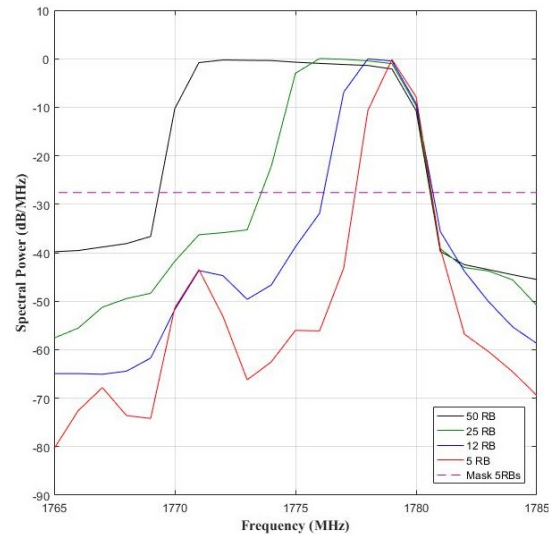

Fig. 3. The RMS power spectra collected for 5, 12, 25, and 50 RBs. The 3GPP mask is shown as a dashed line.

increase their power to compensate for the raise in their noise floor, request to move to a different RB allocation, or change their modulation and coding Scheme (MCS). While these in-band emissions are easily overcome by higher power UEs, new lower-power UEs will likely experience more of an impact.

IV. DISCUSSION AND CONCLUSION

Although most LTE UEs meet the power mask level designated by 3GPP, the limit and shape of in-band interference may be of concern to new lower-power devices. In this paper we measured the spectra emitted by a higher-power LTE UE to illustrate its in-band emissions. As shown in Figure 3, the magnitude of the mirroring effect increases as the number of allocated RBs decreases. Depending on the exact cause of the mirroring, various solutions may be available. For example, if it is caused by I/Q gain imbalance, the path for I/Q needs to be closely balanced. If it is caused by quadrature impairments, then the up conversion modulators may need to be reexamined [1]. Another solution may be to address the impacts of mirroring within the 3GPP community by adjusting the in-band limits such that they are more “friendly” to lower-power UEs. Future study will reveal the impact of in-band emission of high power LTE UEs to the connectivity, performance, battery life, and different type of network traffic.

REFERENCES

- [1] National Instruments, “Introduction. to LTE Device Testing: From Theory to Transmitter and Receiver Measurements”, *National Instruments*.http://download.ni.com/evaluation/rf/Introduction_to_LTE_Device_Testing.pdf
- [2] M. Fry, J. Splett, G. Sanders, J. Ladbury, F. Sanders, A. Kord, R. Jacobs, *Measured Emission Spectra of Selected AWS-3 LTE Transmitters*. NASCTN.
- [3] 3GPP TS 36.521-1 V14.3.0 “Evolved Universal Terrestrial Radio Access (E-UTRA); User Equipment (UE) conformance specification; Radio transmission and reception” <https://portal.3gpp.org/desktopmodules/Specifications/SpecificationDetails.aspx?specificationId=2469>