

BUILDING COMPONENT PERFORMANCE EXPOSED TO FIREBRAND SHOWERS CHARACTERISTIC OF BURNING STRUCTURES

Samuel L. Manzello¹ and Sayaka Suzuki²

¹National Institute of Standards and Technology (NIST), USA

²National Research Institute of Fire and Disaster (NRIFD), Japan

1. INTRODUCTION

There been numerous wildfires that spread into communities, in Argentina, Australia, Brazil, Canada, Chile, France, Greece, Portugal, Spain, and the USA. Such large outdoor fires are referred to as Wildland-Urban Interface (WUI) fires. Japan is another country that has been subject to large scale outdoor fires, such as the recent Itoigawa City Fire that occurred in Niigata, Japan. A prominent mechanism of structure ignition in both WUI and urban fires is the production of firebrands, or embers [1].

Attached building components may provide a pathway for structures to ignite in large outdoor fires. Examples of attached building components may include fencing assemblies. A recent study by the authors demonstrated that fencing assemblies may be ignited by firebrand showers, but the capability of the ignited fencing to transfer the fire to an adjacent structure, such as wall assembly, was not considered [2].

As a result, this paper describes efforts to investigate the ability of firebrand showers to ignite fencing assemblies, and then observe the subsequent flame spread along the ignited assembly to an *adjacent wall*. The fencing assemblies were exposed to firebrand showers similar to those produced from burning structures. As this is a very complex problem, mock-up sections of full-scale fencing/wall assemblies were experimented with using unique experimental capabilities developed by the authors at the National Research Institute of Fire and Disaster (NRIFD).

2. EXPERIMENTAL DESCRIPTION

The reduced-scale firebrand ignition experimental facility was described in a prior JAFSE proceedings [3]. As a result, only a brief description is provided here. The reduced-scale continuous-feed firebrand generator consisted of two parts; the main body and continuous feeding component. For all experiments here, Japanese Cypress wood chips were used to produce firebrands. These were provided from a supplier and upon arrival, these chips were filtered using a 10 mm screen to remove very fine wood pieces.

The chips were also oven dried, as they were shipped under wet conditions. These size wood pieces (average length, width, and thickness are 28, 18, and 3 mm, respectively) were selected to produce firebrands with larger projected area at a specific mass than that used in our prior studies using continuous firebrand generation focused on vegetative firebrands. The wood feed rate used here was 80 g/min, which is near the upper limit for this reduced-scale firebrand generator.

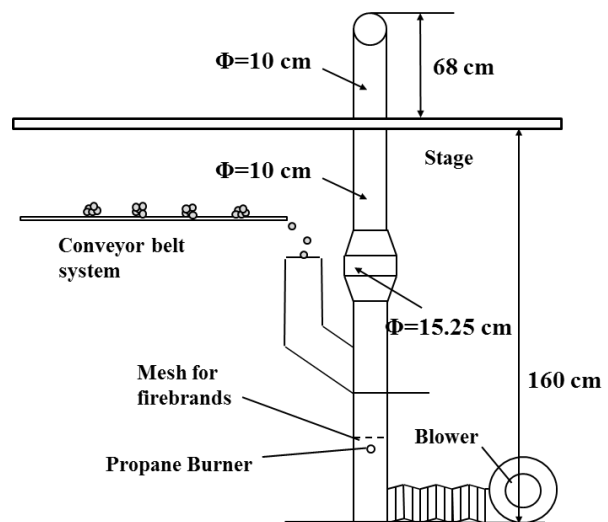

Figure 1 Drawing of reduced-scale continuous firebrand generator.

Since the base of the fan used to generate the wind in the NRIFD facility is located 1.6 m from the floor, the conveyor was placed under a custom stage designed for experiments when using NRIFD's wind facility. The wind field exits from a 4.0 m diameter fan, and it is possible to generate wind speeds up to 10 m/s. The flow field was measured to be within $\pm 10\%$ over a cross-section of 2.0 m by 2.0 m.

The blower was set to provide an average velocity of 4.0 m/s measured at the exit of the firebrand generator when no wood pieces were loaded. In these experiments, glowing firebrands were desired; flaming firebrands were produced if the blower wind speeds were higher.

Redwood lattice fencing assemblies were constructed for the experiments. These were custom fabricated by using two, 0.61 m in height, 1.2 m in width, redwood lattice pieces, and held together using a 2 x 4 wood array. While two-sided redwood lattice fencing assemblies were used in this study, this type of fencing assembly may also be used in a one-sided configuration. Experiments are also underway to investigate the differences between one-sided and two-sided configurations, as well as entirely different fencing types such as Western Red Cedar privacy fencing.

3. RESULTS AND DISCUSSIONS

A total of 10 experiments were conducted for wind speeds of 4 m/s, 6 m/s, and 9 m/s. In all cases, the evolution of the ignition process was similar. Specifically, glowing firebrands ignited the mulch beds (mini-pine bark mulch) via smoldering combustion, and then the mulch transitioned to flaming combustion. These flaming mulch beds then ignited the redwood lattice fencing assemblies. The ignited fencing assemblies then transferred the fire to adjacent walls. **Figure 2-3** displays the temporal evolution of the ignition process for a wind speed of 6 m/s, and 9 m/s, respectively.

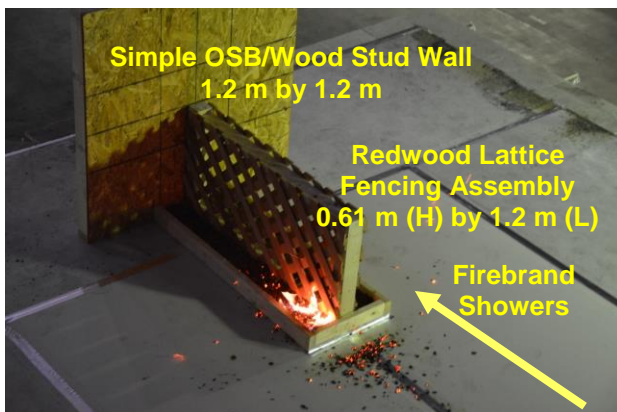

Figure 2 Top - onset of flaming ignition in the mulch bed; bottom - flame spread from the ignited fencing assembly to wall (6 m/s).

In all experiments, the wall was eventually ignited by fire from the redwood lattice fencing

assemblies. Under higher wind speeds (9 m/s), significant firebrands were generated from the redwood lattice fencing as well.

4. SUMMARY

This paper describes efforts to investigate the ability of firebrand showers to ignite fencing assemblies, and then observe the subsequent flame spread along the ignited assembly to an adjacent wall.



Figure 3 Flame spread from the ignited fencing assembly to wall for 9 m/s wind speed.

In particular, recent work compared ignition results from full-scale redwood lattice fencing assembly experiments conducted using the Building Research Institute's (BRI) full-scale wind tunnel facility, to mock-up to sections of full-scale fencing assemblies using the experimental capability at the National Research Institute of Fire and Disaster (NRIFD). As a first step, the fencing assemblies *were not attached* to an adjacent wall. In all cases, the evolution of the ignition process was similar to the full-scale fencing assembly experiments [4].

The results in the present conference paper set the stage to conduct a similar comparison across varying sized experiments regarding the evolution of flame spread from ignited fencing assemblies to *adjacent walls*.

5. ACKNOWLEDGEMENTS

Mr. Marco Fernandez of NIST is acknowledged for shipping materials for experiments.

6. REFERENCES

- [1] Manzello, S.L., *et al.*, Fire Saf. J., 59:122-131, 2013.
- [2] Suzuki, S., *et al.*, Fire Tech., 52: 1051-1067, 2016.
- [3] Suzuki, S., and Manzello, S.L, 27th Annual JAFSE Symposium, 2015.
- [4] Manzello, S.L., *et al.*, Fire and Materials Conference Proceedings, 2017.