

# Frequency shift mitigation in a cold-atom CPT clock

Xiaochi Liu<sup>1</sup>, Eugene Ivanov<sup>2</sup>, John Kitching<sup>1</sup>, and Elizabeth A. Donley<sup>1</sup>

<sup>1</sup>Time and Frequency Division, NIST, Boulder, Colorado, USA

<sup>2</sup>School of Physics, the University of Western Australia, Perth, Australia

**Abstract**— An upgrade in the laser system for our cold-atom clock based on coherent population trapping is described that makes use of an electro-optic modulator to significantly improve the phase coherence of the interrogation spectrum relative to what was achieved with our previous phase-locked loop approach. With this improvement in phase coherence, we have observed a reduction in the light shift by over two orders of magnitude. We present the impact of this improvement on the performance of the clock, for which the light shift was previously dominated by the incoherent light in the laser spectrum. We also demonstrate a new optical setup to reduce the Doppler shift.

**Keywords**—Phase-locked loop, coherent population trapping, light shift, AC Stark Shift, electro-optic modulator

## I. INTRODUCTION

Systems producing phase-coherent optical signals separated by a few gigahertz are required for the development of various quantum-mechanical devices including those based on Coherent Population Trapping (CPT) [1]. A common technique for generating this light is to use Optical Phase-Locked Loops (OPLLs), which is the approach that we initially applied for our cold-atom CPT clock [2-4]. This technique enables a high degree of phase control, provided that both master and slave lasers have narrow linewidths and the control system has relatively high loop bandwidth [5]. However, it is also desirable to produce the bichromatic light with compact single-section DBR and DFB lasers, which are characterized by broad linewidths that are of the same order of magnitude as their frequency modulation bandwidth.

In the present work, we describe an upgrade to our interrogation spectrum achieved by generating the interrogation light with a fiber-coupled electro-optic phase modulator (EOM). We also present an initial evaluation of the impact of the improved spectrum on the light shift in our cold-atom CPT clock. For this clock, the light shift was previously dominated by phase noise in the CPT spectrum due to incomplete phase locking [4]. We show that the sensitivity to light shifts is much reduced with the improved spectrum.

## II. OPLL VERSUS EOM LIGHT SOURCE

In [2], we described a bichromatic light source based on two single-section distributed Bragg reflector lasers phase-locked across the 6.835 GHz hyperfine ground-state splitting of <sup>87</sup>Rb. With this approach, the fraction of total power in the coherent carrier of the beat note was limited to about 70 %. The lack of complete phase coherence is due to the slowness

of the laser diode's frequency response. Single-section diode lasers typically exhibit a phase reversal in their frequency modulation response in the 0.5 MHz to 10 MHz range due to the crossover between thermally and carrier-density induced tuning regimes [6], which limits the maximum achievable bandwidth of the OPLL in our system to about 1 MHz. Since this is comparable to the linewidth of the free-running lasers, the degree of coherence between master and slave is limited with this approach.

To improve the coherence of the bichromatic light for the CPT excitation, we switched to a fiber-coupled phase EOM-based light source. Fiber-coupled phase EOMs are characterized by broad bandwidths (> 10 GHz) and low  $\pi$  phase-shift voltages. They are well suited for the generation of multi-frequency phase-coherent laser beams when they are driven by low-noise microwave signals. Fig. 1 shows the scheme of the CPT clock with the EOM-based light source.

The phase coherence between the two sidebands generated by the EOM is much higher than the OPLL based two-laser system. The beat-note spectrum of the EOM-based light source shows an improved coherence of ~99% -- a significant improvement over the 70 % achieved with the OPLL. A disadvantage of the EOM-based approach is that some of the optical power is in sidebands that do not contribute to the CPT signal but can nevertheless contribute to light shifts and noise.

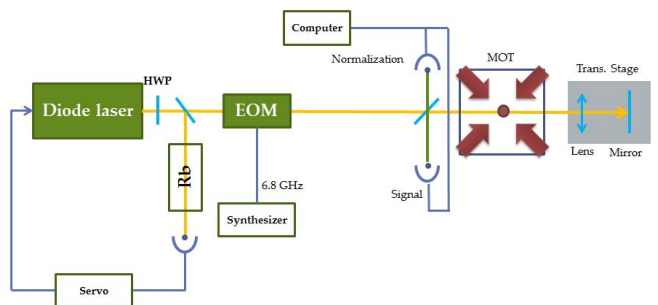

Fig. 1. Basic scheme of the cold-atom CPT clock with the EOM-based light source. The diode laser is frequency-stabilized by use of the saturated absorption technique. The EOM was modulated by a 6.835 GHz microwave signal and carefully temperature-stabilized. The frequency synthesizer that drives the EOM is referenced to the 10 MHz output of a hydrogen maser so that we can perform absolute frequency measurements.

## III. EFFECT OF IMPROVED COHERENCE ON LIGHT SHIFTS

We have performed preliminary measurements of the light shift in two EOM configurations with the lin || lin CPT

interrogation technique and  $D_1$  laser excitation [7]. In one configuration, we took the modulated light with all of the sidebands directly from the output of the EOM and used the entire spectrum to excite CPT signals. In a second configuration, we tried to generate a nearly perfect CPT spectrum by selecting the desired sideband by filtering the EOM output with a Fabry-Perot cavity and recombining the beam with the unmodulated laser output. In this case, the spectrum contained only the two frequency components needed for CPT excitation and no unwanted sidebands.

To characterize the light shift, we used a Ramsey period of 16 ms, a CPT pulse length of 1 ms, and we varied the intensity and optical detuning of the CPT light. We typically set the EOM modulation amplitude such that the first-order sidebands each had roughly equal power as the carrier, for which the short-term clock stability is best. We also measured the clock frequency versus sideband amplitude (discussed below).

In the simplest arrangement for interrogation with the full output spectrum of the EOM, we were able to achieve the smallest light shift. A measurement of clock frequency versus optical detuning in this configuration is shown in Fig. 2. With a high optical intensity, the frequency shift was nearly independent of intensity and detuning and was  $-0.002(3)$  Hz/MHz. This sensitivity to detuning is smaller by a factor of 350 compared to our previous system based on an OPLL [4]. At this level, the laser frequency only has to be stabilized to 340 kHz for the light shift bias to be reduced to the  $1 \times 10^{-13}$  level, which can be easily satisfied with the saturated absorption technique.

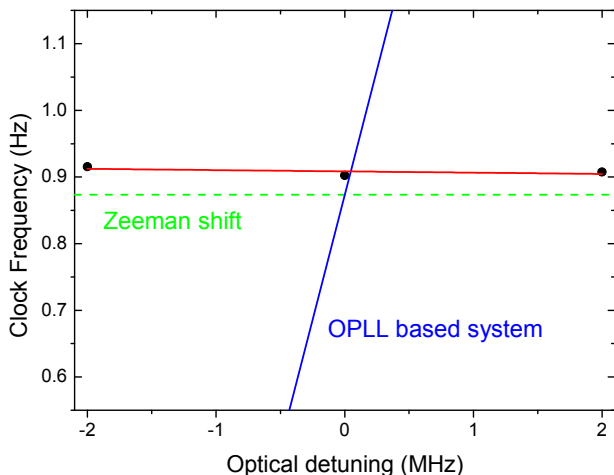

Fig. 2. Light shift vs optical detuning with  $5 \text{ W/m}^2$  total light intensity and interrogation with all of the sidebands. The red line is a linear fit, which gives a light shift of  $-0.002(3)$  Hz per megahertz of optical detuning, which is consistent with zero. The green dashed line indicates the Zeeman shift, and the blue line indicates the light shift versus detuning observed with the OPLL-based system.

The frequency shift versus the optical detuning was also measured in the filtered Fabry-Perot-based configuration. Here, the spectrum only contained the two components needed for CPT. Although the frequency shift sensitivity to detuning was three times smaller than the previous OPLL

system, it was much larger than the one shown in the Fig 2. This could be the result of a few different factors. Firstly, because of losses in the cavity, we were only able to operate the clock at intensities less than  $1 \text{ W/m}^2$  in this configuration, at which level the coherent part of the light shift is still evident. Secondly, the commercial filter cavity that we used added significant intensity noise to the filtered component, and potentially also phase noise from the different beam paths.

#### IV. FREQUENCY SHIFT DUE TO THE EOM SPECTRUM

The measured frequency shift is about 0.06 Hz higher than the Zeeman shift (0.9 Hz) by using our new EOM-based light source (Fig. 1). The origin of this frequency shift is still to be determined, but we have found that it is sensitive to the sideband modulation index. Fig. 3 shows the frequency shift as a function of the RF power applied on the EOM.

The modulation index for EOM with a constant RF power input is known to drift due to temperature variations, photorefractive effects and aging, which could result in frequency shifts if the modulation index is not actively stabilized.

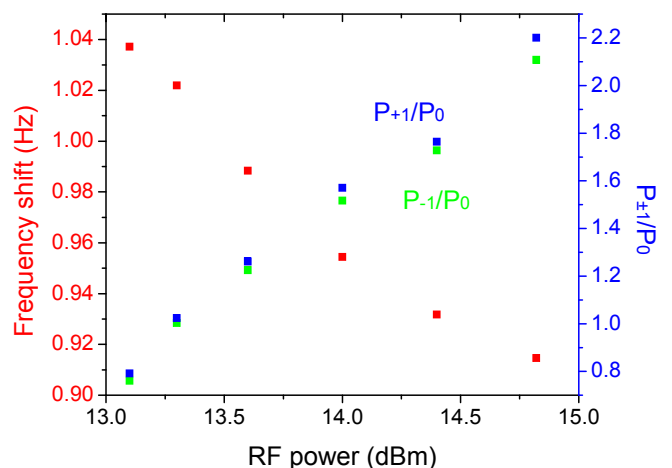

Fig. 3. Frequency shift as a function of the RF power applied on the EOM (red) and the ratio between the power of the first order sidebands and the carrier signal (blue and green). Here, 0.9 Hz is the known Zeeman shift resulting from the applied magnetic field.

#### V. DOPPLER SHIFT MITIGATION OPTICAL SETUP

The Doppler shift is another dominant systematic that can degrade the long frequency stability of the clock. The Doppler shift introduced in our clock mainly arises because the atoms are free to move through the phase fronts of the interrogation field during interrogation and they move by more than a millimeter during the Ramsey period due to gravity.

The Doppler shift can be well cancelled in an optical setup with counter-propagating CPT beams if the intensities of the forward- and backward-travelling beams are equal and the beams are well overlapped [3].

In a counter-propagating optical setup with a simple flat mirror retroreflector, the optical power of the incident beam and the reflected beam are not exactly equal because of losses from the MOT cell walls and absorption of the atoms. For our AR-coated cell, the losses from the cell walls total  $< 2\%$ . Losses from atom cold-atom absorption can be much larger and can approach  $10\%$  over the extent of the atom cloud, leaving a shadow in the retroreflected beam. To reduce the effect of the intensity imbalance resulting from the atom shadow, we use a cat's-eye retroreflector comprised of a lens and a flat mirror, with the lens positioned in front of the mirror by the lens focal length (see Fig. 4a). We position the atoms in the CPT beams such that they are in the upper half of the beams for the first Ramsey pulse and in the lower half of the beam for the second Ramsey pulse. With this approach, the Doppler shift is reduced by about one order of magnitude compared to our previous optical setup based on a simple flat retroreflector, as measured by translating the retroreflector.

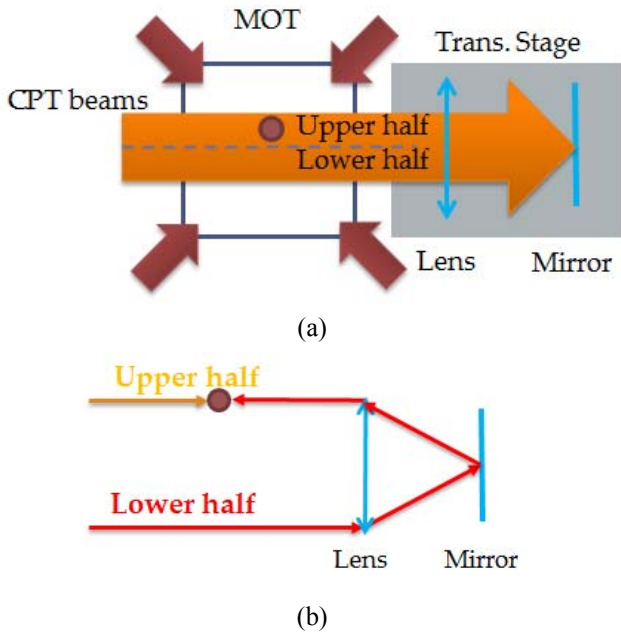

Fig. 4. a.) Doppler shift mitigation optical setup. b.) Ray traces showing the input and retroreflected rays that strike the atoms during the first Ramsey pulse. This geometry prevents the shadow from hitting the atoms for the reflected beam. For the second Ramsey pulse, the atoms are in the bottom of the beam (not shown).

With the new improvements to the light shift and Doppler shift, the short-term frequency stability of the clock is measured to be  $1.5 \times 10^{-11}/\sqrt{\tau}$  and decreases after 4000 seconds to the level of  $1.25 \times 10^{-13}$  (Fig. 5).

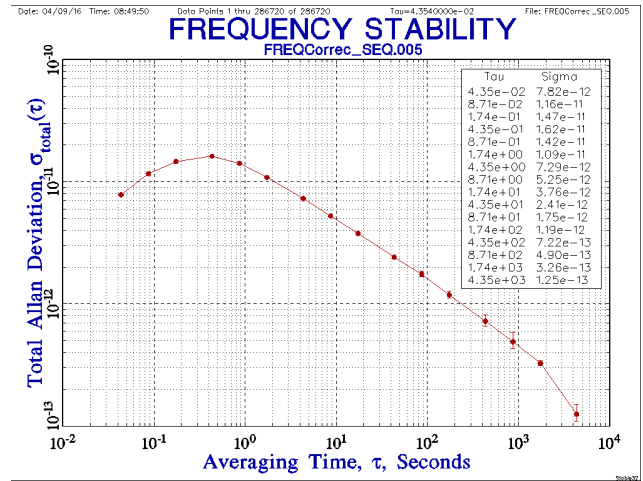

Fig. 5. Clock frequency stability.

## VI. OUTLOOK

The reduced light shift with improved CPT laser coherence is consistent with our predictions in [4]. The clock instability that we currently achieve has been improved compared to what we measured in the OPLL-based system ( $4 \times 10^{-11}/\sqrt{\tau}$ ), but has yet to be fully optimized. Our next work will focus on stabilization of the EOM, reduction of the frequency shift introduced by the EOM, and optimizing the operating parameters.

The EOM-based system has the advantage over the OPLL-based approach in that only one interrogation laser is required. If the clock were based on  $D_2$  interrogation, then it could be possible to perform all of the laser cooling and interrogation with a single  $D_2$  laser and EOM modulation.

## ACKNOWLEDGEMENT

This work is funded by NIST, which is an agency of the U.S. government, and is not subject to copyright.

## REFERENCES

- [1] J. Vanier, "Atomic clocks based on coherent population trapping: a review," *Applied Physics B*, vol. 81, pp. 421-442, 2005.
- [2] E. N. Ivanov, F. X. Esnault, and E. A. Donley, "Offset phase locking of noisy diode lasers aided by frequency division," *Review of Scientific Instruments*, vol. 82, 2011.
- [3] F. X. Esnault, E. Blanshan, E. N. Ivanov, R. E. Scholten, J. Kitching, and E. A. Donley, "Cold-atom double- $\Lambda$  coherent population trapping clock," *Physical Review A*, vol. 88, 2013.
- [4] E. Blanshan, S. M. Rochester, E. A. Donley, and J. Kitching, "Light shifts in a pulsed cold-atom coherent-population-trapping clock," *Physical Review A*, vol. 91, p. 041401, 2015.
- [5] J. Ye and J. L. Hall, "Optical phase locking in the microradian domain: potential applications to NASA spaceborne optical measurements," *Optics Letters*, vol. 24, pp. 1838-1840, 1999.
- [6] M. Ohtsu, *Highly coherent semiconductor lasers*. Boston, London: Artech House Publishers, 1992.
- [7] A. V. Taichenachev, V. I. Yudin, V. L. Velichansky, and S. A. Zibrov, "On the unique possibility of significantly increasing the contrast of dark resonances on the  $D_1$  line of  $^{87}\text{Rb}$ ," *JETP Lett.*, vol. 82, pp. 398-403, 2005.