

Testing Spectrum Sensing Networks by UAV

Daniel G. Kuester, Ryan T. Jacobs, Yao Ma, and Jason B. Coder

U.S. Department of Commerce
National Institute of Standards and Technology
Communications Technology Lab, RF Technology Division
Boulder, CO, USA

daniel.kuester@nist.gov, ryan.jacobs@nist.gov, yao.ma@nist.gov, jason.coder@nist.gov

Abstract—We consider here the use of hovering unmanned aerial vehicles (UAVs) to test spectrum sensing capabilities of Citizen’s Broadband Radio Service (CBRS) systems at 3.5 GHz. Aircraft transmit synthesized LTE or pulsed radar modulation to excite spectrum sensing nodes on the ground. This kind of test could be useful either to validate a system during development or to check a deployed system in the field. Technical challenges that will need to be addressed include rotor blade effects on signal fidelity, waveform parameter selection, and understanding of positioning estimation and control.

I. INTRODUCTION

The Federal Communication Commission (FCC) is developing rules for a proposed new CBRS in the 3.55 GHz – 3.7 GHz band [1]. The rules establish three tiers of service. The highest priority tier is allocated to incumbent users, notably including the U.S. Navy, who will continue to operate shipborne radar systems under the existing band allocation. The new second tier CBRS is allocated to priority access licenses (PALs) intended for commercial broadband service, and assigned through a competitive bidding process. The new lowest priority tier CBRS is called General Authorized Access (GAA), where users may access channels opportunistically.

Devices transmitting in CBRS tiers must vacate the band during use by users in higher-priority tiers. Incumbent users, as the highest tier, are to have the strongest protections against interference. This is to be achieved by means of a spectrum access system (SAS). The SAS tries to monitor the spectrum in order to detect incumbent or PAL users in the band in time and space. On detection, the SAS directs PAL and/or GAA devices to vacate the band.

Widespread deployment of a CBRS network will require buy-in from both incumbents and the potential CBRS industry. Strong testing for the effectiveness of SAS spectrum sensing is one piece of this problem. This type of test could validate system performance with less operator time and effort (and therefore expense). It could also help to understand the repercussions of CBRS network design and policy on a larger scale than is practical in human-performed tests that are difficult to repeat.

We consider here unmanned aerial vehicles (UAVs) outfit with calibrated transmitters as tools in this measurement problem. The aircraft is to transmit surrogate “radar-like” signals to mimic first-tier incumbent users or broadband waveforms like LTE to mimic second-tier PAL service.

II. UAV TRANSMISSION PLATFORM

A. Overview

Initial UAV work is a demonstration system composed of a consumer quad-rotor UAV mounted with a 3.5 GHz calibrated transmitter payload. The transmitter is preloaded with recorded or synthesized modulation waveforms, and played back at preprogrammed intervals.

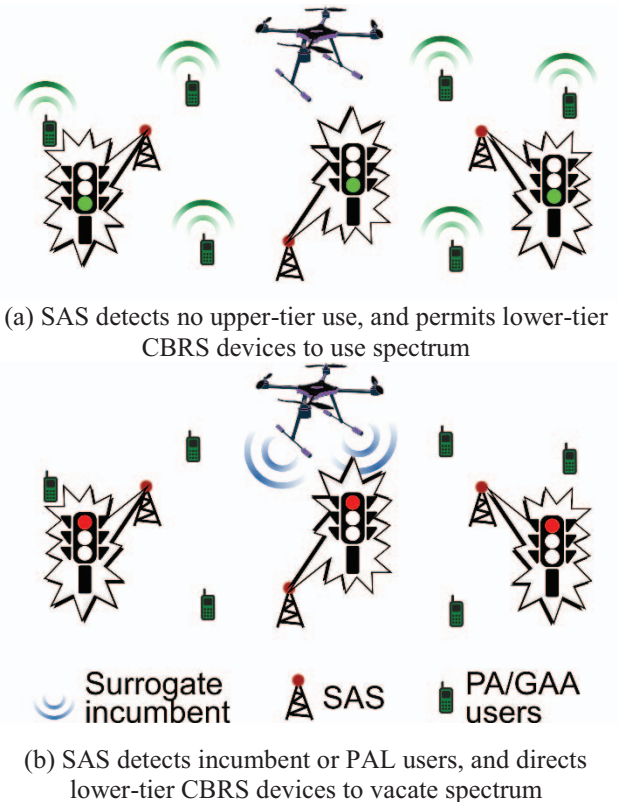

Fig. 1. Expected device behavior in the 3.5 GHz CBRS spectrum sensing test scenarios.

TABLE I. TRANSMITTER SPECIFICATIONS

Parameter	Nominal	Measured
RF peak conducted power out	30 dBm	TBD
Waveform sample depth	73 MS	TBD
Nyquist Modulation bandwidth	14 MHz	TBD

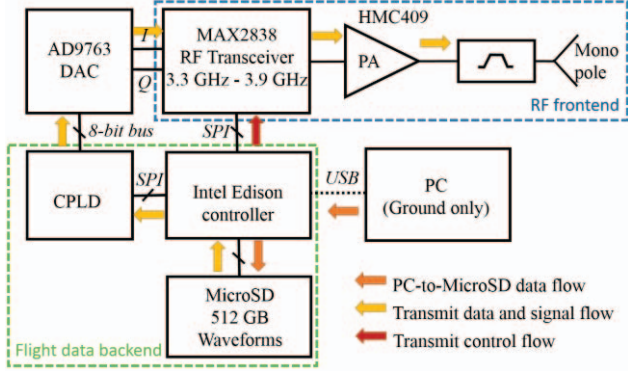

Fig. 2. Block diagram for a prototype transmitter to be mounted on the aircraft.

B. Test Signal Synthesis

The UAV is illustrated in test operation in Figure 1. Figure 1a shows the expected ground network response when the UAV transmitter is silent. Turning on the transmitter leads to the expected behavior shown in Figure 1b. The specific response of each tier depends on whether the SAS receives incumbent or PAL tier transmission.

When the UAV synthesizes LTE modulation, the SAS should identify the spectrum use, and direct PAL or GAA users to behave appropriately. If the UAV synthesizes radar waveforms, the SAS should direct both PAL and GAA users to vacate the band. Failure to do so would invite improvements to the CBRS network implementation.

Incumbent Navy radar systems and modulation parameters are not generally available to the public, so a surrogate imitation waveform needs to be identified and synthesized. Previous work by the NTIA [2] identified parameters of several types of marine radar, and may serve as a suitable basis.

C. Payload Design

The RF transmitter payload architecture under development is illustrated in Figure 2. The transmitter is intended to transmit a carrier with “playback” of a custom baseband waveform that is preloaded on UAV flash memory. The MicroSD card stores up to 73 Msamples of quadrature (I and Q) baseband. The transceiver supports up to 14 MHz of Nyquist bandwidth. This combination allows custom modulation waveform storage and playback for up to 5 seconds. Further specifications are listed in Table I. RF bandwidth and power are most limited by the tight size, weight and power (SWAP) constraints of the platform.

One characteristic to investigate will be the effect of rotor blade modulation on the integrity of the transmit signal. Previous work [3] has identified modulation in full-sized helicopters. Common small UAVs have plastic rotor blades, so we believe this effect is likely to be small.

D. Positioning Uncertainty

We need to characterize the positioning uncertainty of the UAV in order to ensure test repeatability. In this context, it is important to understand the uncertainty of both aircraft control and logged position. The aircraft comes integrated with GPS for control and position logging, corresponding with position uncertainty on the order of 1 m to 2 m. We may be able to improve this accuracy by other means, which could include differential GPS or optical tracking.

III. CONCLUSION

Robust testing of spectrum sensing systems by UAV has potential to improve the amount and quality of test data available compared to human time and effort on foot or by car. Upcoming efforts at NIST may help to evaluate the practicality of this type of RF test at the current state of the art in unmanned aircraft.

REFERENCES

- [1] Federal Communications Commission, “Report and Order and Second Further Notice of Proposed Rulemaking,” GN Docket No. 12-354, April 2015.
- [2] FH Sanders, JE Carroll, GA Sanders, RL Sole, “Effects of Radar Interference on LTE Base Station Receiver Performance,” NTIA Report 14-499, May 2014.
- [3] AC Polycarpou, CA Balanis, A Stefanov, “Helicopter Rotor-Blade Modulation of Antenna Radiation Characteristics,” *IEEE Trans. Ant. Prop.*, Vol. 49, No. 5, May, 2001.