

NIST Special Publication 1201

**Measurement Challenges and
Metrology for Monitoring CO₂
Emissions from Smokestacks –
Workshop Summary**

Presenters

Aaron N. Johnson
Rodney A. Bryant
Tamae Maeda Wong
James R. Whetstone
Toralf Dietz
Donald Giel
David Elam Jr.
Scott Swiggard
Woong Kang
Iosif Shinder
Eric Harman
Hsin-Hung Lee
Liang Zhang
Keith Gillis
Richard Grot

This publication is available free of charge from:
<http://dx.doi.org/10.6028/NIST.SP.1201>

NIST Special Publication 1201

Measurement Challenges and Metrology for Monitoring CO₂ Emissions from Smokestacks – Workshop Summary

Aaron N. Johnson
*Sensor Science Division
Physical Measurement Laboratory*

Rodney A. Bryant
*Fire Research Division
Engineering Laboratory*

Tamae Maeda Wong
James R. Whetstone
Special Programs Office

Toralf Dietz
Sick Engineering GmbH

Donald Giel
Teledyne Monitor Labs

David Elam Jr.
TRC Environmental Corp.

Scott Swiggard
Golden Specialty Inc.

Woong Kang
*Korea Research Institute of
Standards and Science (KRISS)*

Iosif Shinder
Sensor Science Division

Physical Measurement Laboratory

Eric Harman
*Colorado Engineering
Experiment Station (CEESI)*

Hsin-Hung Lee
*Industrial Technology
Research Institute (Taiwan)*

Liang Zhang
*National Institute of
Metrology (China)*

Keith Gillis
*Sensor Science Division
Physical Measurement Laboratory*

Richard Grot
*LAGUS Applied
Technology Incorporated*

This publication is available free of charge from:
<http://dx.doi.org/10.6028/NIST.SP.1201>

Month and Year of Publication

U.S. Department of Commerce
Penny Pritzker, Secretary



National Institute of Standards and Technology
Willie May, Under Secretary of Commerce for Standards and Technology and Director

Disclaimer

NIST Special Publication 1201 is intended to capture external perspectives related to NIST standards, measurement, and testing-related efforts. These external perspectives can come from industry, academia, government, and other organizations. This report was prepared as an account of a workshop; it is intended to document external perspectives; and does not represent official NIST positions.

Certain commercial entities, equipment, or materials may be identified in this document in order to describe an experimental procedure or concept adequately. Such identification is not intended to imply recommendation or endorsement by NIST, nor is it intended to imply that the entities, materials, or equipment are necessarily the best available for the purpose.

**National Institute of Standards and Technology Special Publication 1201
Natl. Inst. Stand. Technol. Spec. Publ. 1201, 121 pages (December 2015)
CODEN: NSPUE2**

This publication is available free of charge from: <http://dx.doi.org/10.6028/NIST.SP.1201>

Preface

NIST traceable standards, reference materials and certifications have provided advances in measurement sciences and calibrations needed for industry to compete in the global economy. Emissions monitoring for electric power generation is a vital sector that merits investments for industrial competitiveness and regulatory effectiveness. Responding to the needs of the public, private industries, and regulatory agencies, NIST has supported scientific research and technology development to provide the best measurement standards and innovation in instrumentation. Electric power is the engine for U.S. industry and commercial growth. Therefore effective action is needed to meet regulatory requirements and improve greenhouse gas measurements.

Coal and natural gas are important domestic resources in the U.S. Both provide over 65% of the nation's electricity and serve the economic demand for stable, reliable, and cost effective electric power. Accurate and reliable emissions monitoring from smokestacks is thus vital for complying with regulations and minimizing environmental and health effects. NIST's role in supporting this industry is to improve the accuracy in emissions measurements and to minimize the uncertainty in operating conditions, testing, and analysis.

Developing standards and establishing common measurements has benefits beyond ensuring optimal emissions monitoring operations and meeting regulatory compliance. It offers the opportunity to make improvements and develop procedures that can form industry standards. Best practices can be developed and dialog can begin with other emissions monitoring operations, local and state regulators, and more importantly the community in which the source resides. Standards and reference materials are not only to fulfill management demands or regulatory oversight; they offer a baseline from which improved systems can develop. Thus, NIST's role is not only to provide a service but to catalyze innovation by empowering experts in the field.

The opportunities to share best practices between measurement experts (e.g., National Metrology Institutes - NMIs) and emissions monitoring specialists are limited. As such, NIST organized a forum to bring together all interested parties including NIST research staff, research staff from other NMIs, industrial professionals and researchers, regulators, and equipment suppliers. The venue is intended to generate ideas for broad improvements in the field by sharing solutions to common emissions monitoring problems.

Opportunities that empower experts and simulate improvements can achieve far reaching impact by involving the international community. Understanding the challenges and factors that can provide improvements should be shared not only in the U.S. but with experts in other

countries. While clean coal is making improvements in many U.S. power plants, basic monitoring systems are only beginning to be introduced in other countries where smog is a serious health risk. In China, for example, it is reported that a new coal fueled power plant is built each month. New technologies and engineering expertise are valuable assets that merit support by any nation. To realize Greenhouse Gas (GHG) reductions globally, lessons learned and best practices must be widely disseminated.

Addressing climate change will require accurate measurements for greenhouse gases, and stable long term reference standards to measure small variations over long periods of time. Such measurements will contribute to better reporting values, and in turn build confidence for the industry. To achieve clean energy systems, commitment to sound engineering practices built upon scientific standards that are accepted by users, regulators, and consumers is a first step. Participants of this workshop are actively engaged in that process.

James R. Whetstone

Special Assistant to the Director for Greenhouse Measurements

Acknowledgements

The success of any workshop is dependent on the hard work of multiple individuals. We wish to thank all participants for their contributions and engaging discussions. We are sincerely grateful for the candid exchange of knowledge, experiences, and best practices. We especially want to thank the presenters for providing valuable information that stimulated important discussions and served to open new opportunities to exchange insights. Your contribution was an important catalyst for the workshop's success. In addition we wish to express our sincere thanks to Gina Kline of the Fluid Metrology Group for her expert assistance, logistics arrangements, and workshop tours. A sincere thanks is also extended to Iosif Shinder for hosting a tour of the NIST Wind Tunnel.

Aaron Johnson, Rodney Bryant, Tamae Wong, and James Whetstone

Table of Contents

Preface	i
Acknowledgements	iii
1. Introduction.....	1
1.1 Overview of the NIST Greenhouse Gas and Smokestack Projects.....	2
2. CEMS and RATA Measurements.....	4
3. Pitot Probe Characterization and Calibration	9
4. NIST Facilities and Flow Measurement Research.....	10
5. Closing Remarks.....	16
6. References	17
7. Appendices	19
7.1 Appendix A: Workshop Agenda	19
7.2 Appendix B: List of Attendees	21
7.3 Appendix C: Workshop Presentations	23
7.3.1 <i>NIST Greenhouse Gas and Climate Science Measurements Program</i>	23
7.3.2 <i>Improving the Accuracy of CEMS by Means of Multipath Ultrasonic Flowmeter</i>	26
7.3.3 <i>Practical Experience with CEMS Measurements</i>	34
7.3.4 <i>Overview of ASTM D7036: A Quality Management Standard for Emission Testing</i>	40
7.3.5 <i>Volumetric Flow Measurements of Stationary Sources: Common Mistakes, Corrective Measures</i>	45
7.3.6 <i>Stack/Duct Flow Measurements – Tracer Gas Method ASTM E2029</i>	56
7.3.7 <i>3D Pitot Tube Measurements and Calibration in the Wind Tunnel</i>	60
7.3.8 <i>Experimental and Numerical Investigations of the Factors Affecting the S-type Pitot Tube Coefficients in GHG Emission Monitoring</i>	65
7.3.9 <i>Greenhouse Gas Emissions – A Case Study on the Calibration of an L-pitot Static Tube</i>	75
7.3.10 <i>NIST’s New 3D Airspeed Calibration Rig Addresses Turbulent Flow Measurement Challenges</i>	83
7.3.11 <i>Scale-Model Smokestack Simulator (SMSS) – A Facility to Study the Uncertainty of CEMS and RATA Flow Measurements</i>	91
7.3.12 <i>Performance Evaluation of Ultrasonic Flow Meters in NIST’s Smokestack</i>	98
7.3.13 <i>Using the National Fire Research Laboratory (NFRL) as a Test Bed for Traceable CO₂ Measurements</i>	107

7.3.14	<i>Is a Long-Wavelength Acoustic Flowmeter Feasible for Smokestacks?</i>	113
7.4	Appendix D: Stationary Source Sampling & Analysis for Air Pollutants (SSSAAP) Conference	121

1. Introduction

Reducing greenhouse gas emissions requires accurate and reliable measurements to evaluate the effectiveness of the mitigation efforts. To address these measurement needs NIST hosted its first workshop on *Measurement Challenges and Metrology for Monitoring CO₂ Emissions from Smokestacks*. The workshop was held on April 20 and 21, 2015 at NIST's Gaithersburg Maryland campus. The purpose of the workshop was to exchange experiences, best practices, and ideas related to current and emerging issues concerning the accuracy of CO₂ emissions measurements from smokestacks. The workshop brought together diverse stakeholders who shared perspectives, and discussed strengths and weakness of current CO₂ emissions measurement protocols. The workshop provided a forum for NIST to share its progress toward improving the accuracy of smokestack CO₂ emissions measurements and establishing a traceability chain that clearly ties these measurements to internationally recognized standards.

The workshop participants included regulators, power plant continuous emissions measurement systems (CEMS) operators, CEMS manufacturers, relative accuracy testing audit (RATA) companies, U.S. wind speed calibration laboratories, NIST¹ staff, and researchers from other National Metrology Institutes (NMIs) with expertise in wind speed and flow measurements. Speakers gave presentations on the following topics:

- RATA² and CEMS³ measurements,
- characterization of different pitot probe types and methods of calibration, and
- newly constructed NIST research facilities focused on providing traceability and improved accuracy of CO₂ emissions measurements.

Although the workshop discussed both concentration and flow measurements, the greater emphasis was placed on improving smokestack flow measurements. This report is organized according to the three discussion topics detailed above. The key points from the presentations and participant discussions are summarized for each topic. For convenience, the appendices include the workshop agenda (Appendix A), list of attendees (Appendix B), and workshop presentations (Appendix C). In addition, we have summarized previous discussions between NIST and members of the stack testing community that served as a precursor to this workshop. (Appendix D).

¹ The National Institute of Standards and Technology (NIST) is the U.S. National Metrology Institute.

² The Relative Accuracy Test Audit (RATA) is a procedure developed by the EPA, and used by certified testers to measure the flow velocity and concentration in a smokestack. RATA testers temporarily install their measurement equipment in a smokestack to calibrate CEMS equipment that is permanently installed in smokestacks.

³ The Continuous Emissions Monitoring Equipment (CEMS) consist of instrumentation permanently installed in smokestack and used to continuously measure both the flow and concentration of regulated pollutants.

1.1 Overview of the NIST Greenhouse Gas and Smokestack Projects

NIST is a non-regulatory agency of the U.S. Department of Commerce and the country's National Metrology Institute (NMI). The mission of NIST is

to promote U.S. innovation and industrial competitiveness by advancing measurement science, standards, and technology in ways that enhance economic security and improve our quality of life.

NIST executes this mission by performing measurement science research with the goal of improving accuracy and ensuring international recognition of measurement methodologies and standards. NIST approaches these tasks in part through cooperative activities with the interested and impacted communities. Hence NIST is working collaboratively with industry, other Federal agencies, and the states to enhance the international acceptance of U.S. measurement standards and methods as a foundation for quantitative, science-based greenhouse gas emission inventories and offsets.

The main program objectives are to:

- improve the current measurement and standards infrastructure to improve the accuracy of greenhouse gas measurements in the U.S.;
- promote these measurements and standards internationally;
- transfer improved measurement technologies and best practices to other government agencies and the private sector;
- support the measurement standards as needed.

Motivation for addressing CO₂ emissions monitoring from the smokestacks of stationary sources is generated by the significant contribution of CO₂ emissions from the electric power sector. For 2013 the U.S. Environmental Protection Agency (EPA) estimated that electricity generation accounts for 31% of total CO₂ equivalent emissions. [1]

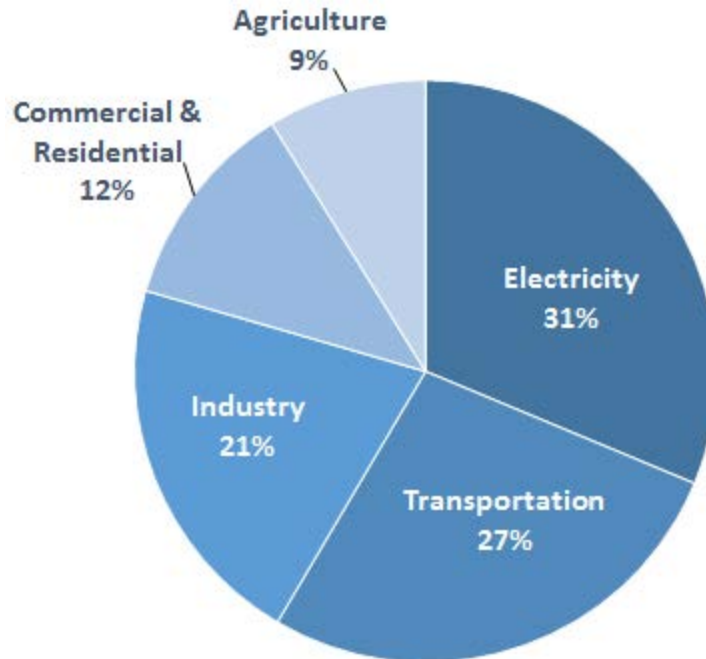

Figure 1 Total U.S. Greenhouse Gas Emissions by Economic Sector in 2013. Total = 6673 Million Metric Tons of CO₂ equivalent. (<http://www.epa.gov/climatechange/ghgemissions/sources.html>)

Carbon dioxide emissions determination from electrical generation plants may be based on either fuel calculation or continuous emissions monitoring (CEM) methodologies. Comparisons of these two methods have been published in the scientific literature [2, 3], primarily for coal-fired plants, and indicate a significant disparity in emission values. Independent NIST investigations of similar data also indicate such a disparity. Both methodologies are recognized by the International Panel on Climate Change as acceptable methodologies for reporting greenhouse gas emissions inventory information. Assessment of measurement challenges presented by both methodologies indicates that focusing on continuous emissions monitoring technologies as a means to improve the accuracy of emissions data in the electrical generation sector has the highest likelihood to improve such data. In addition, CEMS are recognized as being in the top tier of determination methodologies supporting inventory reporting. Since total flow rate of stack gases is an essential part of the CEMS measurement, NIST has embarked upon a measurement science research program for directly improving the accuracy of stack flow rate measurements.

Should greenhouse gas mitigation efforts begin in the U.S., they will quite likely be complemented by similar efforts in other countries. Greenhouse gas inventory reports will likely become the metric by which nations gauge their compliance or contribution to worldwide mitigation objectives. Understanding the challenges and sharing technological advances among

nations to improve emissions data from the electric power sector can have positive impact on efforts to reduce emissions globally.

2. CEMS and RATA Measurements

The session was moderated by Rodney Bryant, NIST, and presentations were provided by the following workshop participants:

Toralf Dietz, Sick Engineering

Donald Giel, Teledyne

David Elam Jr., TRC and STAC

Scott Swiggard, Golden Specialty

The amount of CO₂ emitted from a stationary source such as an electric power plant is measured by a continuous emissions monitoring systems (CEMS). CEMS are permanently installed at the smokestack and measure pollutant concentration (*e.g.*, CO₂), and the bulk or volumetric flow of gas through the smokestack. The rate of CO₂ emissions equals the product of the measurements of volume flow rate and CO₂ concentration. The EPA requires periodic (annual) calibration of a smokestack's CEMS using a test procedure called a relative accuracy test audit (RATA). Presentations for this session provided a general overview of the flow components of the CEMS and the flow RATA procedure, as well as presenting some of the technical challenges to consider.

The majority of CEMS flow measurement devices are ultrasonic meters (USM). The device measures the time of flight of an acoustic signal along a given path to infer gas velocity. USMs are very accurate for ideal flow profiles; however, stack flows are complex and present challenges to achieve high accuracy. Two flow related factors that reduce USM accuracy are cross flow or swirl (*i.e.*, flow not parallel to the axis of the stack), and a non-uniform axial velocity profile. Both phenomena are typical in smokestacks and caused by blowers that are used to move flue gas toward the smokestack and by bends and obstructions in the conduit used to transport the flow into the smokestack. Other important sources of flow uncertainty are dimensional uncertainty components and any bias errors introduced by the RATA. Dimensional uncertainty sources include measurements of the stack diameter as well as the length and angle of the USM acoustic path.

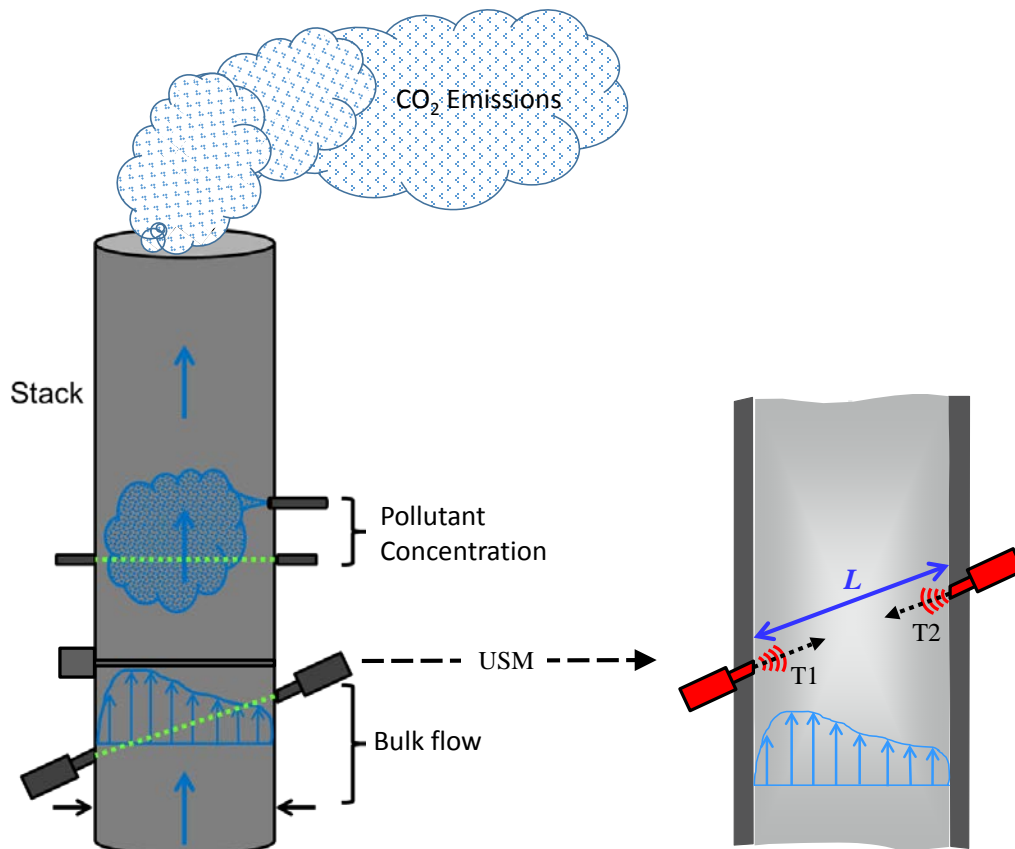

Figure 2 Schematic of stack mounted CEMS with a single path ultrasonic meter installed. The flow velocity is determined by correlating the times of flight ($T1$ and $T2$) of the ultrasonic signals propagating with and against the flow over a measured distance (L).

Technical strategies are available to help improve USM measurement errors related to the complexity of the flow field and dimensional uncertainty components. For example, a USM can be equipped with multiple measurement paths to account for profile skew and/or swirl. Dual crossing path USMs (*i.e.*, x-pattern) are already in use and provide partial compensation for swirl effects. Empirical and computational evidence shows that additional paths would likely improve USM measurement accuracy. In addition, precision dimensional measurements can be applied to reduce the uncertainty of acoustic path length and duct diameter. The frequency and the path angle of the acoustic transducers can be optimized for the application. A promising technique is the use of computational fluid dynamics (CFD) to optimize installations and perform a virtual calibration of the USM for the anticipated flow distribution.

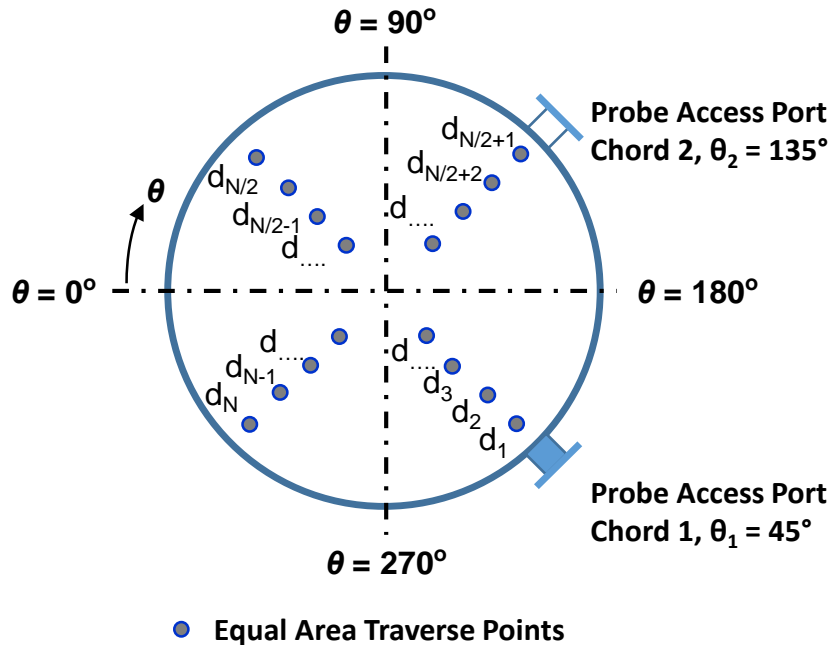

Figure 3 Schematic of flow RATA traverse points along 2 diametric chords in the cross section of a smokestack. Flow velocities are measured at each point with a pitot probe.

All CEMS flow measurement devices must be calibrated with a flow RATA. A flow RATA is a detailed measurement of the average gas velocity and hence the volume flow rate in the smokestack. The flow RATA uses pitot probes to measure the velocity of the stack gas at discrete points across the cross section of the smokestack. The principle of operation of the pitot probe is: differential pressure across the pitot ports is correlated to the fluid velocity via a calibration factor. Of the three types of pitots, standard L-type, S-type, and three-dimensional, the S-type is the most widely used for flow RATAs. The pitot probes are traversed along two orthogonal chords and the velocity measurements are used to generate a representative sample of the flow distribution. Volumetric flow is determined by averaging the point velocity measurements and multiplying by the cross sectional area. The relative accuracy is the percent difference between the volumetric flow determined by the RATA with that determined by the CEMS.

The flow RATA is the reference standard for the flow measurement; hence the CEMS measurement is only as good as the flow RATA. Current flow RATA measurements are not rigorously traceable to NIST primary flow standards. As such, the flow RATA cannot determine the absolute uncertainty of a CEMS measurement, but instead only provides *relative accuracy* between the EPA Method and the CEMS flow monitor. Even if this difference is small, it does not guarantee a low uncertainty flow measurement. A CEMS flow monitor that is recurrently calibrated against the same type of probe in the same flow conditions could yield consistent

good agreement with RATA results, and yet have a significant uncertainty. To quantify the absolute uncertainty of CO₂ emissions measurements requires establishing rigorous metrological traceability.⁴ That is, CO₂ emissions must 1) be tied back to NIST primary standards via an unbroken chain of measurements; 2) have known and documented uncertainty for each step in the chain; and 3) have maintained all of the measurement equipment used in the CEMS and the RATA in a quality system that ensures the fidelity of the measurement uncertainties. The calibration hierarchy or traceability chain, shown in Figure 4, portrays how CO₂ emissions measurements must be tied back to NIST primary standards.

A subtle and often overlooked aspect of satisfying condition 2 includes accounting for uncertainties related to differences between the flow conditions during calibration versus application. For example, S-probes are generally calibrated in swirl-free conditions, but are used in swirling flow conditions. The swirling flow impacts the device's measuring performance, but is not accounted for in the uncertainty budget. In these cases metrological traceability is not established.

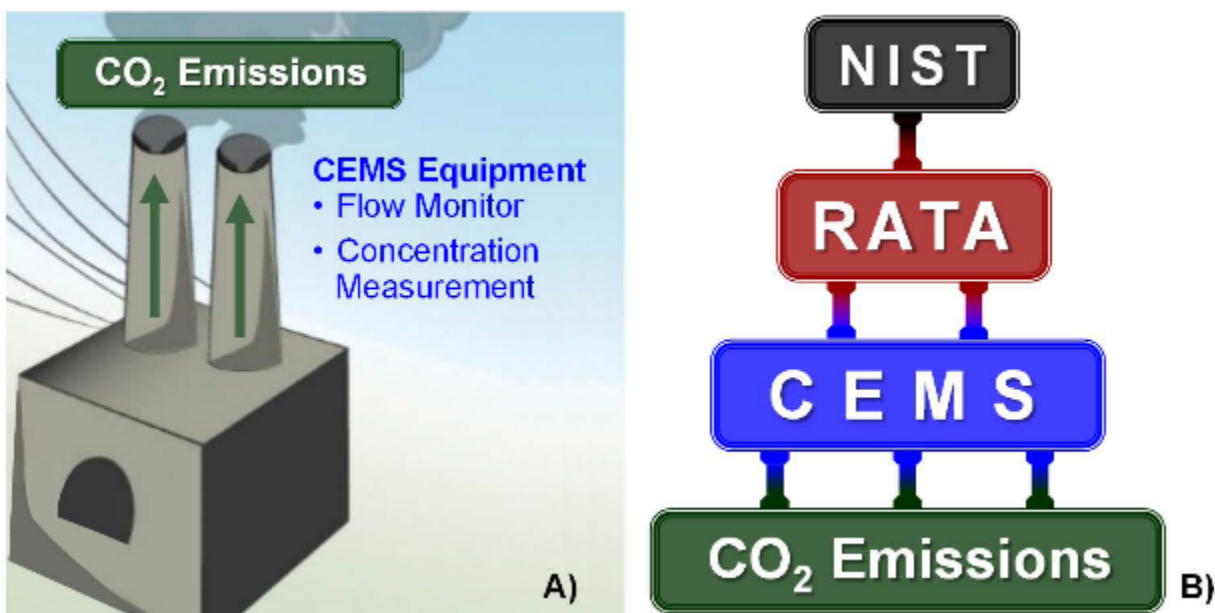

Figure 4 CO₂ emissions measured by CEMS (A)⁵, and the corresponding metrological traceability chain to NIST standards (B).

Conducting a flow RATA is a manual process and therefore subject to errors and mistakes. Examples of common mistakes that can significantly reduce the accuracy of flow RATAs are: improper or infrequent measurements of stack diameter; using damaged probes; not accounting for cyclonic flow in the measurement; conducting test during transient or non-

⁴ http://www.nist.gov/pml/mercury_traceability.cfm

⁵ Image used with permission of the Utah Geological Survey

steady conditions; and transcribing the wrong values. Some Air Emission Testing Bodies (AETBs), companies that conduct the flow RATAs, are adopting quality management standards such as ASTM D7036 [4] in order to reduce these common mistakes and increase the quality of their product. Figure 5 provides an overview of ASTM D7036. Steps such as adopting a quality management program, introducing redundant measurements for real-time quality checks, or introducing automated procedures and data collection have demonstrated improved measurement precision and in some cases improvements in customer (i.e. power plant) performance. However these steps are only reflective of the AETBs that invest in quality management accreditation and careful measurements.

An Overview of ASTM D7036	
Purpose	Enables Air Emission Testing Bodies (AETBs) to deliver data of defined and documented quality
Applicability	For use by firms making emission testing measurements. Required by USEPA for AETBs performing Part 75 tests.
History	First published in 2004. Modeled after ISO 17025.
Current Version	2012, but no material change from 2004 version
Accreditations	≈ 5 Accredited AETBs, 18 Interim Accredited AETBS
Benefits	Ability to perform Part 75 work. Excellent platform for AETBs involved in other ISO 17025-based standards. Consistent, predictable delivery of services. A management standard without scope limitations.
Criticisms	Adoption expense, accreditation expense, “won’t change data quality,” just a “paper exercise.”

Figure 5 Overview of ASTM D7036 - Standard Practice for Competence of Air Emission Testing Bodies

An alternative stack flow measurement technique is the tracer gas dilution method. The method is based on the conservation of mass. A known concentration of tracer gas is injected in a duct or stack and the airflow is determined by measuring the tracer concentration downstream from the injection site to determine the dilution ratio. In situations where traditional flow measurements cannot be conducted due to hazards or obstructions, this method provides an effective alternative. The tracer dilution method is independent of flow conditions such as angle, swirl, or turbulence but is subject to uncertainty due to incomplete mixing of the tracer in the stack flow. The measurement does not require a measurement of stack diameter, which is typically a significant source of error.

3. Pitot Probe Characterization and Calibration

This session was moderated by Aaron Johnson, NIST, and presentations were provided by:

Woong Kang, KRIS⁶

Iosif Shinder, NIST.

Eric Harman, CEESI⁷ and

Hsin-Hung (Kyle) Lee, ITRT⁸

Richard Grot, Lagus Applied Technology

The flow RATA provides the basis of accuracy and traceability of smokestack flows. Accurate flow RATA rely on how well a pitot probe can measure the flue gas axial velocity at discrete points in the cross section of a smokestack. Currently, most flow RATA are performed without using a calibrated S-type probe. Instead the calibration factor is assumed to be 0.84 as long as the geometric requirements of the probe are met. However, the accuracy of this assumed value is unknown, and stack testers have reported values ranging from 0.72 to 0.84 (Appendix D). To what degree does the calibration of an S-type probe depend on velocity? What is the pitch and yaw response of various types of pitot probes? Does turbulence affect the performance of pitot probes? Research programs have been established to answer these questions. Researchers from NIST, KRIS, ITRT, and CEESI identified above described their work, their wind speed facilities, and showed calibration data for different types of pitot probes.

NIST's wind tunnel has a 2 m long test section with a rectangular cross sectional area of 1.2 m by 1.5 m. Wind speed is measured using either a calibrated L-type probe installed in the tunnel or with a Laser Doppler Velocimetry system. The facility has an uncertainty of 0.42 % for wind speeds ranging from 6 m/s to 26 m/s (20 ft/s to 85 ft/s). The wind tunnel can control turbulence intensity levels from 0.1 % to 20 % by installing a turbulence generator upstream of the test section. The NIST wind tunnel has an automated traversing system to change the pitch and yaw angles of pitot probes during a calibration. [5] The NIST research program includes

- Understanding the effect of turbulence on pitot probes
- Characterizing the pitch and yaw angle response of pitot probes
- Characterizing the velocity dependence of S-probe and multi-hole pitot probe calibrations

⁶ The Korea Research Institute of Standards and Science (KRIS) is the Korean National Metrology Institute.

⁷ The Colorado Engineering Experimental Station Inc. (CEESI) is a U.S. flow calibration laboratory.

⁸ The Industrial Technology Research Institute (ITRI) is Taiwan's National Metrology Institute.

- Probe alignment effects, and
- Intercomparisons with other National Metrology Institutes to demonstrate proficiency and support uncertainty claims



Figure 6 NIST wind tunnel used for calibration of S-type, L-type, and 3D pitot probes.

NIST presented preliminary data showing 1) the velocity dependence of the S-probe calibration factor differing from the assumed value of 0.84, 2) pitch and yaw response of an S-probe, and 3) the effect of turbulence on a five hole three-dimensional pitot probe. [5, 6] Presentations made by KRISS showed similar results for S-probe velocity dependence and pitch and yaw response. [7] ITRI showed progress toward development of a fully automated wind tunnel to calibrate pitot probes as a function of pitch, yaw, and velocity. [8] Finally, CEESI presented an alternate methodology (other than using a wind tunnel) to calibrate pitot probes. [9]

4. NIST Facilities and Flow Measurement Research

Research advances at the NIST facilities were presented by the following researchers during this session which was moderated by James Whetstone, NIST.

Aaron Johnson, NIST Physical Measurements Laboratory

Liang Zhang, NIM, China

Rodney Bryant, NIST Engineering Laboratory

Keith Gillis, NIST Physical Measurements Laboratory

Current flow measurement accuracy is based on the RATA, which is not necessarily traceable to the derived SI⁹ unit for flow through NIST standards. NIST is working toward establishing internationally recognized and highly accurate measurement standards to provide an SI traceable basis to quantify the accuracy of CO₂ emissions measurements. These standards will enable the owners of stationary sources and the regulatory agencies for these sources to improve the accuracy of CO₂ emissions. Better measurements are needed so that well-characterized scientific data can be used as the basis to determine if local, regional, and global emission targets are being met. NIST programs are focused on quantifying CO₂ emissions from fossil-fuel-burning power plants due to their significant carbon footprint.

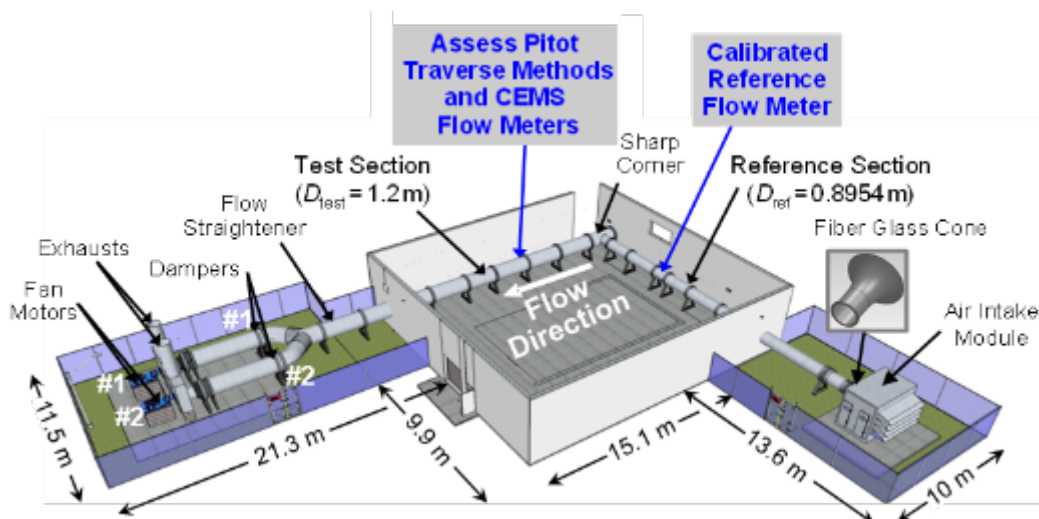

Figure 7. Schematic of NIST Scale-Model Smokestack Simulator (SMSS). A calibrated flow meter in the reference section is used to assess both the EPA RATA and a CEMS flow meter installed in the 1.2 m diameter test section. The sharp corner introduces swirling, asymmetric flow in the test section that is similar to the complex flow conditions in an industrial-scale smokestack. (<http://www.nist.gov/pml/div685/grp02/scale-model-smokestack.cfm>)

NIST has designed and built two independent reference facilities, the Scale-Model Smokestack Simulator (SMSS), Figure 7, and the National Fire Research Laboratory (NFRL), Figure 9. The SMSS will be used to quantify the flow uncertainty of the EPA RATA and CEMS measurements; and the NFRL will be used as a near industrial-scale test bed to evaluate the overall performance of CEMS and RATA methods. The SMSS has the capability to independently vary many of the parameters (e.g., number of diametric chords, number of points on each chord, levels of swirl in the velocity field, the axial velocity magnitude and profile) affecting the accuracy of the flow RATA and flow CEMS such as ultrasonic flow meters. [10] Recently completed computational fluid dynamics modeling indicates that such meters may be able to provide low-uncertainty flow measurements.

⁹ SI is an abbreviation for the international System of Units



Figure 8 SMSS air intake unit, reference section, test section, and air exhaust

The SMSS is essentially a 1/10th scale horizontal smokestack that uses air as a surrogate for flue gas. The test section and reference section of the SMSS facility are housed indoors while the air intake and air exhaust sections are outside. Ambient air is drawn into the air intake unit by 2 fans at the facility exit depicted in the Figure 8. The air enters the facility at relatively low speeds (2 m/s to 8.5 m/s) and is accelerated to air speeds ranging from 11 m/s to 46 m/s in the 0.9 m diameter reference section, and subsequently to speeds of 6 m/s to 26 m/s in the 1.2 m diameter test section.

The SMSS is designed to produce nearly ideal flow conditions (i.e., a symmetric velocity profile with negligible swirl) in the reference section. This well-conditioned flow is measured using an 8 path ultrasonic flow meter (USM) with an expanded uncertainty of 0.5 % at a 95 % confidence level. Flow distortions are introduced in the Test Section by the sharp 90 degree corner. This geometry is typical of many industrial smokestacks and results in swirling, asymmetric flow in the SMSS test section. Other velocity profiles can be generated at the test section by using flow “de-conditioning” plates upstream. If there are no leaks in the connecting volume between the reference section and the test section and the flow is steady, the mass flow measured in the

reference section can be used to assess the performance of different flow meter technologies (e.g., CEMS and RATA) installed in the test section.



Figure 9 The National Fire Research Laboratory (NFRL). CO₂ emissions are predicted using fuel consumption measurements for natural gas. The predicted CO₂ emissions are used to quantify the accuracy of CEMS and RATA measurements in the rooftop exhaust ducts. (http://www.nist.gov/el/fire_research/nfrl.cfm)

The NFRL is used for the study of full-scale fires in buildings. During the routine fire experiments conducted in the facility, the flow and concentration of effluents in the exhaust duct are measured, much like CEMS measurements at the smoke stack of a stationary source. Therefore the NFRL will be used to simulate some of the operating conditions of a fossil-fuel burning power plant. Research results from the SMSS for improving flow RATA accuracy will be applied in the NFRL and therefore under more realistic conditions.

The NFRL has the capability of deriving CO₂ emissions from fuel consumption measurements while simultaneously measuring CO₂ emissions using its exhaust duct CEMS. It has two natural gas burners that can operate at heat release rates up to 8 MW and 20 MW. Measurements of volume flow rate, pressure, temperature, and gas composition are made in the natural gas delivery system just upstream of the burners, making it possible to compute the amount of CO₂ generated by the fire, Figure 10. Large canopy exhaust hoods capture the combustion products from the natural gas fires and direct the flow into the exhaust ducts that run along the roof of the facility. The maximum exhaust flow capacity is approximately 100 kg/s of air. The exhaust ducts are instrumented to measure gas temperature, gas velocity, and gas volume fraction of selected combustion products, including CO₂. From these measurements the direct emissions of CO₂ are derived as in a CEMS measurement, Figure 10. These two measurements, fuel

calculation and flue gas CEMS, are independent and therefore provide a method to check measurement accuracy. [11, 12]

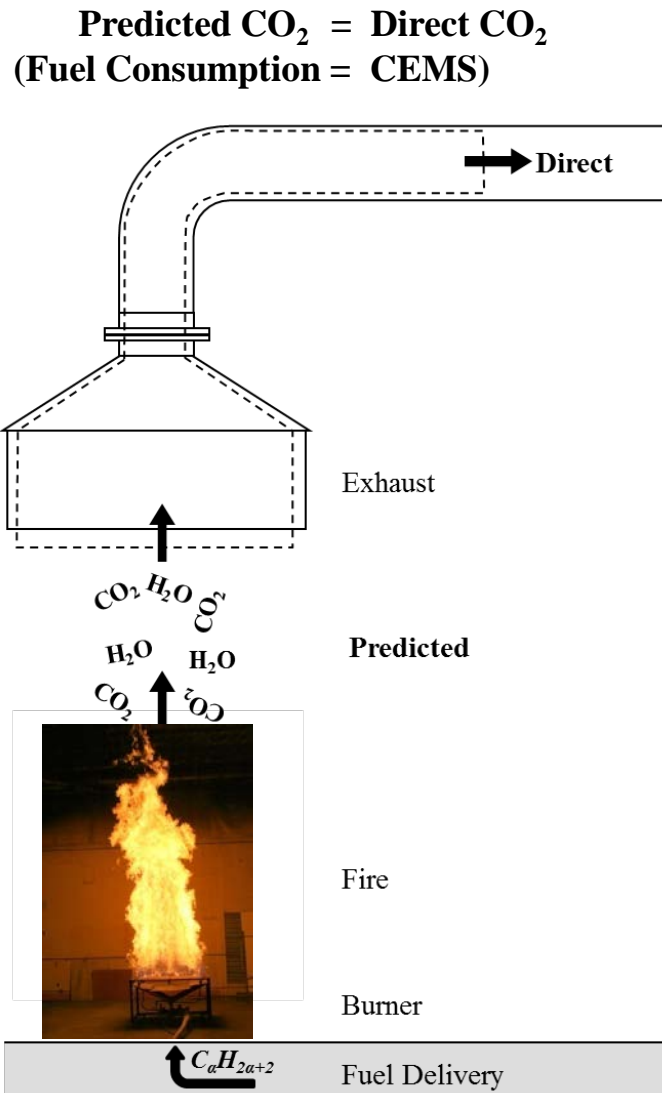

Figure 10 Schematic of the process comparing the fuel consumption and CEMS measurements for accuracy.

These NIST facilities will be used to study new methods of accurately measuring smokestack flows. Efforts will focus on assessing the accuracy of multipath ultrasonic flow meters and researching the potential of long wavelength acoustic flow meters (LWAMs). [13] Single path and dual crossing path ultrasonic flow meter designs are already widely used as CEMS flow meters. However, these designs do not correct for profile effects and offer only limited compensation for swirl. In contrast, multi-path designs would effectively compensate for both swirl and profile effects. Preliminary CFD models predict that multi-path ultrasonic flow meters would significantly reduce errors over the currently used single and dual path designs. [14]

Both facilities will be used to assess the accuracy of multipath ultrasonic flow meter designs in asymmetric swirling smokestack flows.

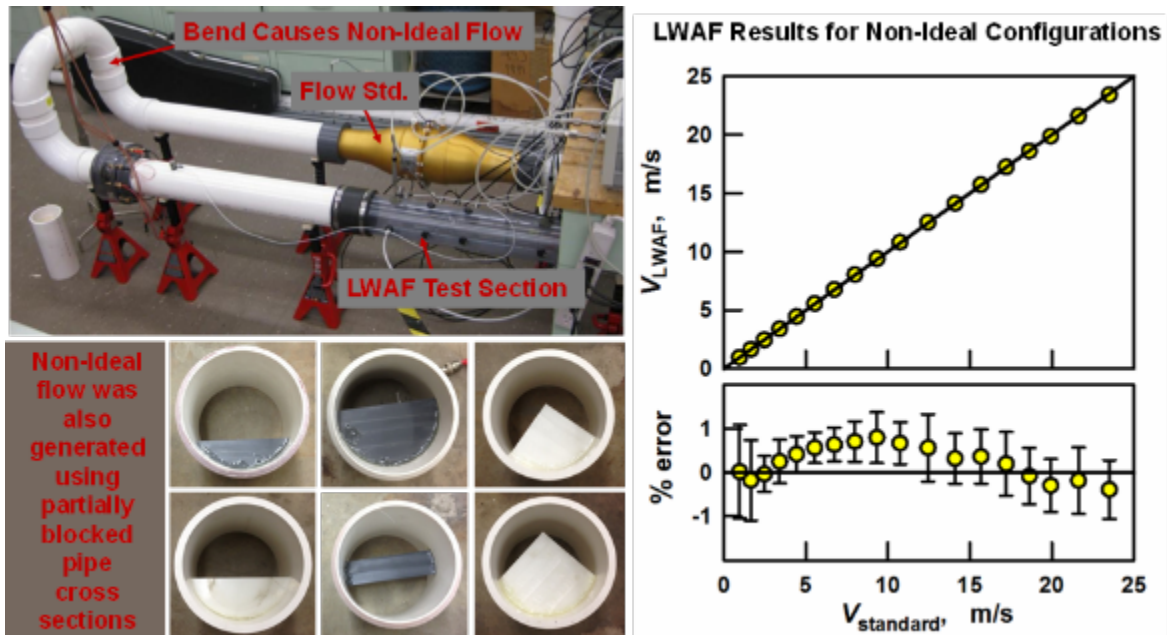

Figure 11 NIST 1/100th scale Long Wavelength Acoustic Flow Meter (LWAF). Results show good agreement between LWAF and a NIST traceable flow standard (better than 1 %) over flows ranging from 1 to 24 m/s for a variety of non-ideal flow conditions.

Preliminary research is underway to assess the effectiveness of a long wavelength acoustic flow meter (LWAF) as an alternative method of measuring the flue gas flow rate. Existing single path and dual path ultrasonic flow meters are subject to installation effects that only measure the velocity over a small fraction of the smokestack cross section. In particular, the short millimeter wavelengths used in ultrasonic flow meter technologies measure the average velocity along narrow beams across the smokestack cross section. If the velocity measured along the acoustic path or length of the sound beam is not indicative of the overall flow field, then results will include sampling errors. Increased sampling via multi-path ultrasonic flow meter designs is one method to reduce such sampling errors. The LWAF offers an alternative approach. In this case, the frequency of the sound wave is such that the wavelength is larger than the duct diameter. As a result, wave fronts distorted by the complex velocity field approach a plane wave that averages over the flow distortions. In this way, a LWAF inherently accounts for the flow distortions present in smokestack flows. Preliminary results for a 1/100th scale LWAF show accuracy better than 1 % in highly asymmetric and swirling flow fields. [13, 15] To verify the scalability of the method, LWAFs will be tested in NIST's 1/10th SMSS.

5. Closing Remarks

The workshop convened experts at a time when attention to atmospheric conditions and demand for accurate measurement testing were on the rise. It anticipated the timely need to foster collaborative intervention by involving the broad stack testing community in dialog, to identify critical issues, explore differing perspectives, and assess best practices. Additionally, it provided a unique opportunity for NIST to share its research interests and progress with a diverse group of stakeholders in the electric power industry. Conversely, feedback from workshop participants enabled better understanding of current CO₂ emission measurement practices and sources of uncertainty. Finally, the workshop enabled NIST to make connections with both U.S. and international stakeholders in the electric power industry. These connections will be useful for continued feedback of NIST research programs and in realizing NIST long-term objectives which include 1) improving GHG measurement standards and the accuracy of GHG measurements, 2) promoting these measurements and consensus standards internationally, 3) transferring measurement technologies and best practices to other government agencies, industrial organizations, and to the private sector.

6. References

- [1] EPA, Inventory of U.S. Greenhouse Gas Emissions and Sinks: 1990-2013, (2015).
- [2] K. V. Ackerman and E. T. Sundquist, Comparison of two US power-plant carbon dioxide emissions data sets, *Environmental Science & Technology*. 42 (15), 5688-5693 (2008).
- [3] J. C. Quick, Carbon dioxide emission tallies for 210 U.S. coal-fired power plants: A comparison of two accounting methods, *Journal of the Air & Waste Management Association*. 64 (1), 73-79 (2014).
- [4] A. International, Standard Practice for Competence of Air Emission Testing Bodies, Ambient Atmospheres and Source Emissions. (D7036-12), (2012).
- [5] I. I. Shinder, V. B. Chromchenko and M. R. Moldover, NIST's New 3D Airspeed Calibration Rig, Addresses Turbulent Flow Measurement Challenges, 9th International Symposium on Fluid Flow Measurement, Arlington, VA, 2015.
- [6] C. Crowley, Shinder, II and M. R. Moldover, The effect of turbulence on a multi-hole Pitot calibration, *Flow Measurement and Instrumentation*. 33 106-109 (2013). 10.1016/j.flowmeasinst.2013.05.007
- [7] W. Kang, Y. M. Choi, N. D. Trang and H. S. Jang, Uncertainty Analysis of Stack Gas Flowrate Measurement with S-Type Pitot Tube for Estimating Greenhouse Gases Emission, 9th International Symposium on Fluid Flow Measurement, Arlington, VA, 2015.
- [8] H. H. Lee and J. Y. Chen, Automated 3D Traverse System Design and Pitot Tubes Calibration in the Wind Tunnel, 9th International Symposium on Fluid Flow Measurement, Arlington, VA, 2015.
- [9] E. Harman and W. Johansen, Alternate Calibration Methodology for Point-Velocity Devices (Pitot-Tubes, Anemometers, Hot-Wire Probes), 9th International Symposium on Fluid Flow Measurement, Arlington, VA, 2015.
- [10] A. N. Johnson, J. T. Boyd, E. Harman, M. Khalil, J. Ricker, C. Crowley, R. Bryant and I. I. Shinder, Design and Capabilities of NIST's Scale-Model Smokestack Simulator (SMSS), 9th International Symposium on Fluid Flow Measurement, Arlington, VA, 2015.
- [11] R. Bryant, M. Bundy and R. W. Zong, Evaluating measurements of carbon dioxide emissions using a precision sourceA natural gas burner, *Journal of the Air & Waste Management Association*. 65 (7), 863-870 (2015). 10.1080/10962247.2015.1031294
- [12] R. Bryant, O. Sanni, E. Moore, M. Bundy and A. Johnson, An uncertainty analysis of mean flow velocity measurements used to quantify emissions from stationary sources, *Journal of the Air & Waste Management Association*. 64 (6), 679-689 (2014).

- [13] L. J. Gorny, K. A. Gillis and M. R. Moldover, Testing Long-Wavelength Acoustic Flowmeter Concepts for Flue Gas Flows, 8th International Symposium on Fluid Flow Measurement, Colorado Springs, CO, 2012.
- [14] L. Zhang, Performance Evaluation of Ultrasonic Flow Meters in NISTs Smokestack Simulator, 9th International Symposium on Fluid Flow Measurement, Arlington, VA, 2015.
- [15] L. J. Gorny, K. A. Gillis and M. R. Moldover, Calibration of a Long-Wavelength Acoustic Flowmeter Using a Lumped Impedance Acoustic Model, NOISE-CON 2013, Denver, CO, 2013.

7. Appendices

7.1 Appendix A: Workshop Agenda

Measurement Challenges and Metrology for Monitoring CO₂ Emissions from Smokestacks

April 20 – 21, 2015

NIST, Gaithersburg, Maryland, Building 215/C103

April 20, 2015

8:45am Registration

9:00am Welcome / Introductions

9:15am James Whetstone (NIST) *Overview of the NIST Green House Gas and Climate Science Measurements Program*

CEMS and RATA Measurements – Rodney Bryant, Session Moderator

9:45am Toralf Dietz (Sick Engineering) *Improving the Accuracy of CEMS by Means of Multipath Ultrasonic Flowmeter*

10:15am Break

10:30am Donald Giel (Teledyne) *Practical Experience with CEMS Measurements*

11:00am David Elam Jr. (TRC and STAC) *Overview of ASTM D7036: A Quality Management Standard for Emission Testing*

11:30am Scott Swiggard (Golden Specialty Inc.) *Volumetric Flow Measurements of Stationary Sources: Common Mistakes, Corrective Measures*

Pitot Probe Characterization and Calibration – Aaron Johnson, Session Moderator

1:45pm Woong Kang (KRISS) *Experimental and Numerical Investigation of the Factors Affecting the S-type Pitot Tube Coefficients in GHGs Monitoring*

2:15pm Iosif Shinder (NIST) *NIST's New 3D Airspeed Calibration Rig Addresses Turbulent Flow Measurement Challenges*

2:45pm Break

3:00pm Eric Harman (CEESI) *Alternate Pitot-Tube Calibration Methodology Using NIST Traceable Mass Flow Standards*

3:30pm Hsin-Hung (Kyle) Lee (ITRI) *3D Pitot Tube Measurements and Calibration in the Wind Tunnel*

4:00pm	Richard Grot (LAGUS)	Stack Duct Flow Measurements – Tracer Gas Method, ASTM E2029
4:30pm	Discussions	
5:00pm	Adjourn	

April 21, 2015

NIST Facilities and Flow Measurement Research – James Whetstone, Session Moderator

9:00am	Aaron Johnson (NIST)	<i>Scale-Model Smokestack Simulator (SMSS) – A Facility to Study the Uncertainty of CEMS and RATA Flow Measurements</i>
9:30am	Liang Zhang (NIM China)	<i>Performance Evaluation of Ultrasonic Flow Meters in NIST’s Smokestack Simulator</i>
10:00am	Rodney Bryant (NIST)	<i>Using the National Fire Research Laboratory (NFRL) as a Test Bed for Traceable CO₂ Measurements</i>
10:30am	Break	
10:45am	Keith Gillis (NIST)	<i>Is a Long-Wavelength Acoustic Flow-meter Feasible for Smokestacks?</i>
11:15am	Discussions	
12:00pm	Lunch	

NIST Laboratory Tours

1:30 – 3:45pm	Iosif Shinder	NIST Wind Tunnel
	Rodney Bryant	National Fire Research Laboratory
	Aaron Johnson	Scale-Model Smokestack Simulator
4:00pm	Break	
4:15pm	Discussions	
5:00pm	Adjourn	

7.2 Appendix B: List of Attendees

Name	Company	Phone	Email
Rodney Bryant	NIST	(301)-975-6487	rodney.bryant@nist.gov
Yong Moon Choi	Korea Research Institute Of Standards and Science	+82 42 868 5317	ymchoi@kriss.re.kr
Toralf Dietz	Sick Engineering Gmbh	+49 172 3514326	toralf.dietz@sick.de
Chris Dimopoulos	National Physical Laboratory (UK)	+44 20 8943 6127	Chris.dimopoulos@npl.co.uk
David L Elam Jr	TRC Environmental Corporation	(919) 622-1846	delam@trcsolutions.com
Robert Finken	Montrose Air Quality Services, Inc.	(714) 448-6150	bfinken@montrose-env.com
Gerald Fraser	NIST	(301) 975-3797	Gerald.fraser@nist.gov
Donald Giel	Teledyne Monitor Labs, Inc.	(412) 897-6457	dgiel@teledyne.com
Keith Gillis	NIST	(301) 975-2468	keith.gillis@nist.gov
Bobbi Greenwalt	Minnesota Power	(218) 313-4376	bgreenwalt@mnpower.com
Richard Grot	Lagus Applied Technology	(301) 529-3845	ragrot@tracergas.com
Eric Harman	Colorado Engineering Experiment Station, Inc.	(303) 638-1384	eharman@ceesi.com
Heming Hu	National Institute Of Metrology, China	+86 10 6452 5126	huheming@gmail.com
Jenny Jachim	US EPA	(202) 343-9590	Jachim.jenny@epa.gov
Aaron Johnson	NIST	(301)975-5954	aaron.johnson@nist.gov
Woong Kang	Korea Research Institute of Standards and Science	+82 42 8685319	woong.kang@kriss.re.kr
Gina Kline	NIST	(301) 975-4813	Gina.kline@nist.gov
Ching-Yi Kuo	Industrial Technology Research Institute (Taiwan)	+886 3 5741206	ellykuo@itri.org.tw
Jordan Laster	Alliance Source Testing, LLC.	(610) 500-3615	jordan.laster@stacktest.com
Hsin-Hung (Kyle) Lee	Industrial Technology Research Institute (Taiwan)	+886 3 5741221	kylelee@itri.org.tw
Thomas Martz	Electric Power Research Institute	(949) 395-9647	tmartz@epri.com
Michael Moldover	NIST	(301) 975-2459	michael.moldover@nist.gov
David Nuckols	Dominion Generation	(804) 796-6021	david.nuckols@dom.com
Jeremy Schreifels	US EPA	(202) 343-9127	Schreifels.jeremy@epa.gov
David Seidl	Colorado Engineering Experiment Station, Inc.	(970) 897-2711	dseidl@ceesi.com

Iosif Shinder	NIST	(301) 975-5943	iosif.shinder@nist.gov
Joe Simeonsson	Environmental Supply Company, Inc.	(800) 782-2575	joesimeonsson@gmail.com
Hratch Semerjian	NIST	(301) 975-8110	Hratch.smerjian@nist.gov
Lauren Smith	American Association for Laboratory Accreditation	(240) 575-7482	lsmith@a2la.org
Tate Strickler	Montrose Air Quality Services, Inc.		tstrickler@montrose-env.com
Chun-Min Su	Industrial Technology Research Institute (Taiwan)	+886-3-5741205	CMSu@itri.org.tw
Lei Sui	General Electric	(978) 437-7576	lei.sui@ge.com
Scott Swiggard	Golden Specialty, Inc.	(713) 306-2208	sswiggard@goldenspecialty.com
James Whetstone	NIST	(301) 975-2738	james.whetstone@nist.gov
Tamae Wong	NIST	(301) 975-5415	tamae.wong@nist.gov
Liang Zhang	National Institute Of Metrology China	+86 1064525126	zhangliang@nim.ac.cn

7.3 Appendix C: Workshop Presentations

7.3.1 NIST Greenhouse Gas and Climate Science Measurements Program

James Whetstone (NIST)

The NIST Greenhouse Gas and Climate Science Measurements Program was initiated to improve the current measurement and standards infrastructure for accurate measurement of greenhouse gases. Motivation for addressing CO₂ emissions monitoring from smokestacks was generated by the significant contribution of CO₂ emissions from stationary sources such as electric power plants. Continuous emissions monitoring systems (CEMS) are recognized as the top tier methodology for determining and supporting the CO₂ emissions inventory. Since total flow rate of stack gases is an essential part of the CEMS measurement, NIST has embarked upon a measurement science research program for directly improving the accuracy of stack flow rate measurements.

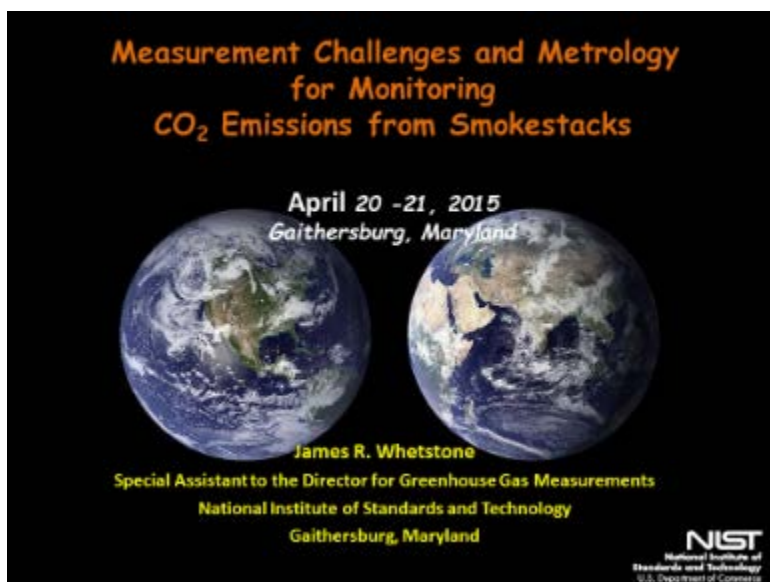

The National Metrology Institute of the U. S.
Greenhouse Gas and Climate Science Measurements

NIST

- Is a non-regulatory agency of the U.S. Department of Commerce
- Is the U.S. National Metrology (measurement) Institute, and
- Develops unbiased, state-of-the-art measurement science that advances the nation's technology infrastructure

Mission:
To promote U.S. innovation and industrial competitiveness by advancing measurement science, standards, and technology in ways that enhance economic security and improve our quality of life.

NIST and Greenhouse Gas Measurements and Standards

- Recent focus established by the NIST Director – 2009
- Mid-Term Objective:
 - Improve performance capabilities of measurements and standards needed to enhance the accuracy of Greenhouse Gas Measurements in the U. S.
 - Promote recognition of these internationally
- Long-Term Objective:
 - Transfer measurement technologies developed to other government agencies and the private sector
 - Support standards responsibilities as needed

NIST
National Institute of
Standards and Technology
U.S. Department of Commerce

NIST's Greenhouse Gas and Climate Science Measurements Program

Objectives:

- Develop advanced measurement tools and standards to improve accuracy capabilities for:
 - Greenhouse gas emissions inventory data
 - Improving emissions measurement data & thereby reporting accuracy
 - Independent methodologies to diagnose and verify emissions data with internationally-recognized methodologies
 - Applications focused on cities and metropolitan areas
 - Remote observing capabilities – satellite and surface-based
 - Extend measurement science and tools underpinning advances in understanding and description of Earth's climate and its change drivers

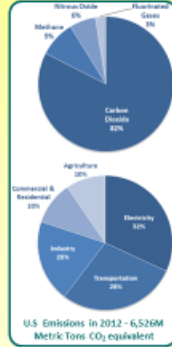

NIST Greenhouse Gas and Climate Science Measurements Program Components

- Stationary/Point Source Metrology
 - Increase accuracy of Continuous Emission Monitoring technology
 - Flow Test Beds - smoke stack simulators
- Geospatially Distributed GHG Source Metrology
 - Measurement Tools and Test Beds Characterizing Emission in Urban GHG Concentration Domes
 - Compare methods to determine GHG Emission Inventory Accuracy – Bottom-up vs. Top-Down
 - Urban GHG dome test beds
 - Indianapolis Flux Experiment (INFLUX)
 - Los Angeles Megacity Carbon Project
 - Northwest Corridor Project
 - Propose an International GHG Metrology Framework Supporting Inventory Diagnosis and MRV Based on Megacities

- Measurement Tools, Standards, and Ref. Data
 - GHG Concentration Standards
 - Spectroscopic Reference Data
 - Surface Air Temperature Assessment
 - Atmospheric Flux Measurement Tools
- Climate Science Measurements- Advanced Satellite Calibration Standards
 - Microwave Observations
 - Advanced Optical Radiometric Methods
 - TOA and Surface Solar Irradiance
 - Surface Albedo Standards
- Measurement Science of Carbonaceous Aerosols
 - Advanced Optical Property Measurements
 - Development of Reference Materials



STATIONARY EMISSION SOURCE METROLOGY

- Motivation and Rationale
- What NIST is Doing



Early CFD Modeling Results in a Stack

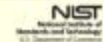
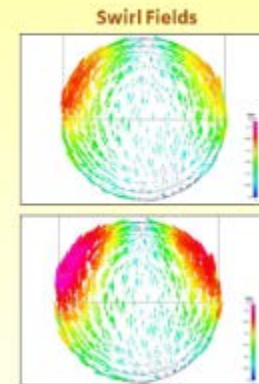
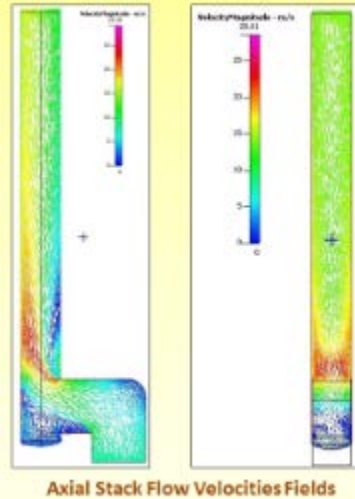

Plume Behavior Appears not to be Laminar



- Flow exiting a stack on a clear, low-wind condition day
- Local Power plant with relatively new stack
- Two vortices appear to be exiting non-partitioned stack

NIST
National Institute of
Standards and Technology
U.S. Department of Commerce

Point Source Metrology: Comparing Fuel Calculation and Direct CO₂ Measurements Using Reported Emission Data

Electricity Generation ~40% of U.S. CO₂ Emissions Inventory

Question:

What is the Agreement Between the 2 Mainly-Used Methods of CO₂ Emissions Reporting Information?

- Fuel Calculation vs. Continuous Emissions Monitoring (CEMs) Methods
- Fuel Consumption and Measured CO₂ Emissions Data – 2005 & 2009 U.S. Reporting
 - Pre-Combustion – Fuel Calculation Method
 - Amount of carbon burned and converted to CO₂
 - Dept. of Energy – Energy Information Administration
 - Annual Steam-Electric Power Plant Design Data: Fuel Type & Quantity
 - Carbon factor or Fuel Carbon Content (kg CO₂/mMBTU)
 - Post-Combustion – CO₂ Direct Measurement via CEMs Technology
 - Direct Measurement (CEMs Data) and Reporting of CO₂, SO₂, NO_x Required by U.S. EPA
- eGRID and EIA 767 databases contain >4800 entries
 - 1804 with primary fuel and annual CO₂ (CEMs) reported values
 - 1066 (2005) and 944 (2009) boilers have complete data for fuel type, mass, energy content, and CEMS CO₂ data



NIST
National Institute of
Standards and Technology
U.S. Department of Commerce

Comparative Analysis:

Fuel Calculated vs Measured CO₂

Accuracy Improvement Potential

• CEM Measurements

- Improve stack gas mass flow measurement
- Reduce gas concentration uncertainty

• Fuel Based Calculations

- Increase fuel carbon (energy content) accuracy
 - Calorimetry and sampling issues
- Improved mass determination
 - Where to make the measurement

• NIST's Investment in Pt. Source Metrology

- Smoke stack simulator - improved flow measurements
- Large Fire Facility – large CO₂ emission source & test bed

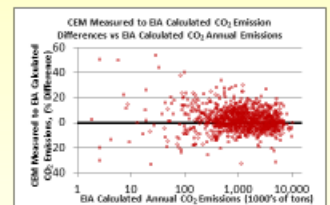
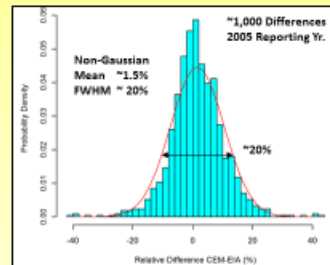

NIST
National Institute of
Standards and Technology
U.S. Department of Commerce

Smoke Stack Simulator - Cold Flow Simulator NFRL - Well Characterized CO₂ Emission Source

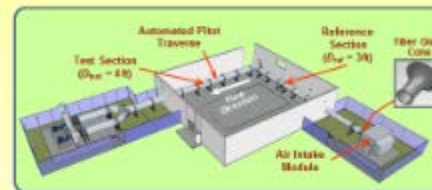

Address flow calibration issues in known, turbulent, swirling flows similar to those in stacks

- Horizontal orientation for cost and safety
- Smokestack Simulator is 1/10th the diameter of typical stack
- At the same velocity range – 5 to 25 m/sec
- Flow traceable to NIST flow standards

Large Emission Source with Accurately Known CO₂ Flux

- Characterize exhaust dust flows (flow RATAs*)
- Establish a mass balance for CO₂ emissions for the facility – O₂ depression calorimetry method
- Apply research results from the NIST Smokestack Simulator
- Provide test bed for new and existing stack mounted flow measurement technologies

* Relative Accuracy & Test Audit

National Fire Research Laboratory (NFRL)



NIST
National Institute of
Standards and Technology
U.S. Department of Commerce

7.3.2 Improving the Accuracy of CEMS by Means of Multipath Ultrasonic Flowmeter

Toralf Dietz (Sick Engineering GmbH)

Session: CEMS and RATA Measurements

This talk presents the application of multipath ultrasonic flowmeters at a coal fired power plant. Specific topics discussed are: the uncertainty analysis of the flow meter installation; the use of Computational Fluid Dynamics (CFD) as basis for an optimized alignment of the measuring paths; improved installation and calibration procedures; and verification of results.



IMPROVING THE ACCURACY OF CEMS BY MEANS OF MULTIPATH ULTRASONIC FLOWMETER



Toralf Dietz
R&D Divison Flow Solutions
20. April 2015

ULTRASONIC FLOW METER MEASUREMENT PRINCIPAL

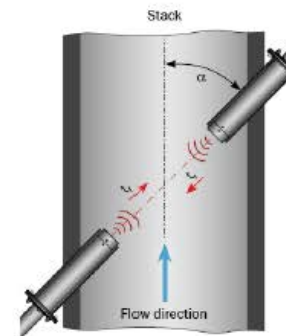

$$t_{AB} = \frac{L}{c + v_p \cos(\alpha)} \quad t_{BA} = \frac{L}{c - v_p \cos(\alpha)}$$

$$v_p = \frac{L}{2 \cos(\alpha)} \left(\frac{1}{t_{AB}} - \frac{1}{t_{BA}} \right)$$

$$Q_v = k \cdot \frac{\pi}{4} \cdot D^2 \cdot v_p$$

- v_p - average velocity on measuring path
- t_{AB}, t_{BA} - transit times
- L - length of measuring path
- D - diameter
- α - installation angle to flow axis
- c - speed of sound
- k - calibration factor

ULTRASONIC FLOW METER MEASUREMENT PRINCIPAL

SICK
Sensor Intelligence.

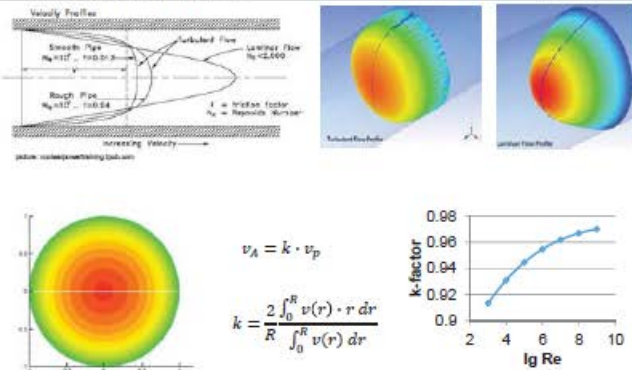

20.01. April 2015 Tord Dietz | HST Workshop Smoke Stack Measurement

3

UNCERTAINTY CONSIDERATIONS FLOW PROFILE

SICK
Sensor Intelligence.

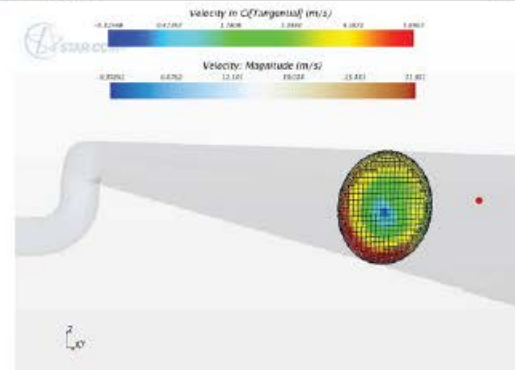

20.01. April 2015 Tord Dietz | HST Workshop Smoke Stack Measurement

4

UNCERTAINTY CONSIDERATIONS FLOW PROFILE

SICK
Sensor Intelligence.

- Swirl adds a velocity component!

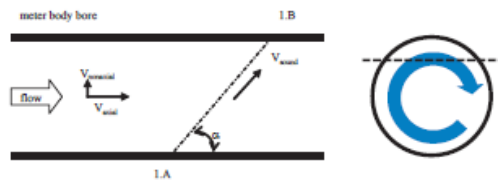

$$t_{AB} = \frac{L}{c + v_p \cos(\alpha)}$$

$$t_{BA} = \frac{L}{c - v_p \cos(\alpha)}$$

$$t_{AB} = \frac{L}{v_{axial} + \cos(\alpha) \cdot (v_{axial} + v_{tangential} \cdot \tan(\alpha))}$$

$$t_{BA} = \frac{L}{v_{axial} - \cos(\alpha) \cdot (v_{axial} + v_{tangential} \cdot \tan(\alpha))}$$

20.01. April 2015 Tord Dietz | HST Workshop Smoke Stack Measurement

5

UNCERTAINTY CONSIDERATIONS FLOW PROFILE

SICK
Sensor Intelligence.

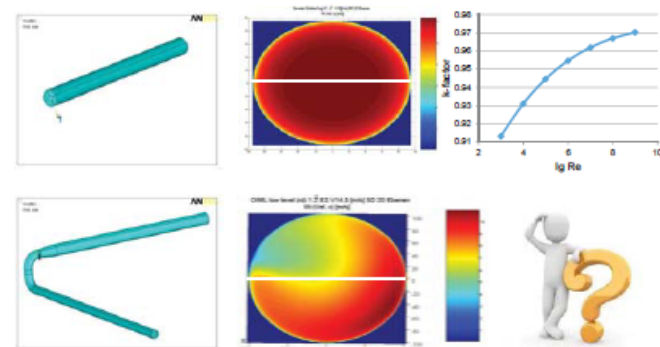

20.01. April 2015 Tord Dietz | HST Workshop Smoke Stack Measurement

6

UNCERTAINTY CONSIDERATIONS
INVESTIGATION SINGLE PATH SYSTEM

SICK
Sensor Intelligence.

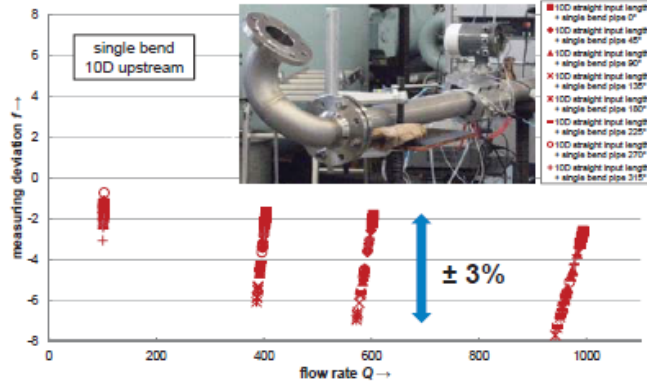

20.01. April 2015 Tümf Dietl | NIST Workshop Smoke Stack Measurement

7

UNCERTAINTY CONSIDERATIONS
INVESTIGATION SINGLE PATH SYSTEM

SICK
Sensor Intelligence.

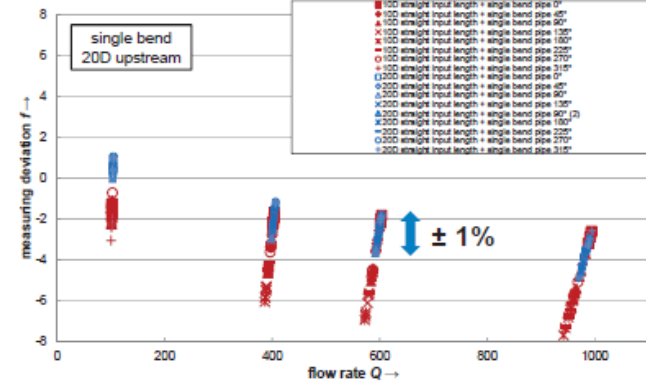

20.01. April 2015 Tümf Dietl | NIST Workshop Smoke Stack Measurement

8

ULTRASONIC FLOW METER
FISCAL METERING GAS TRANSMISSION

SICK
Sensor Intelligence.

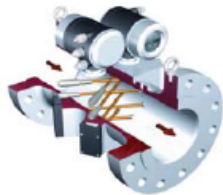

- Size: 2" to 48"
- Pressure: 100bar
- Dry, clean gas
- Machined meter body
- Accurately measured geometry
- Meters are calibrated at a flow lab

20.01. April 2015 Tümf Dietl | NIST Workshop Smoke Stack Measurement

9

ULTRASONIC FLOW METER
FISCAL METERING

SICK
Sensor Intelligence.

ACCURACY CLASSES

- Installation Effects
- Class 1.0: less than 0.33%
- Class 0.5: less than 0.16%

DOCUMENTS

- ISO 17089-1&2
A.G.A. Report 9
OIML R137

Test	Test conditions	Remarks
a	Reference conditions	approx. 50 D straight line approx. 10 D straight line (see Note)
b	A single 90° bend	radius elbow: 1.5 D
c	Double out-of-phase bend	rotating right, radius elbow: 1.5 D
d	Double out-of-phase bend	rotating left, radius elbow: 1.5 D
e	Expander	one step difference of the pipe diameter is applied
f	Reducer	angle of expansion/reduction part $\leq 15^\circ$
g	Diameter step on the upstream flange	approx. +1 % and -1 %
h	Half pipe weld plate	flange shows first bend in piping and mounting of half moon plate

20.01. April 2015 Tümf Dietl | NIST Workshop Smoke Stack Measurement

10



**EXAMPLE
PROJECT DIRECT CO2
MONITORING**



11

**PROJECT DIRECT CO2 MONITORING
SYSTEM OVERVIEW**

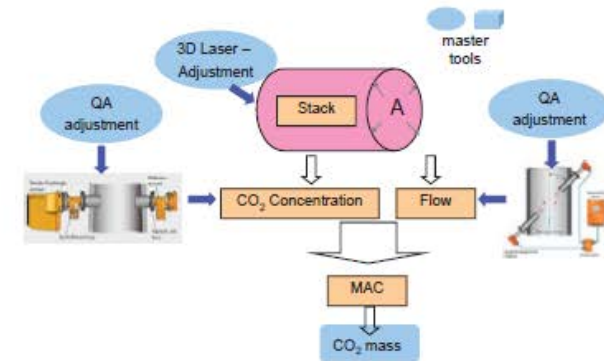

20/21. April 2015 Total DMO | 18ST Workshop Smoke Stack Measurement

12

**PROJECT DIRECT CO2 MONITORING
INSTALLATION**

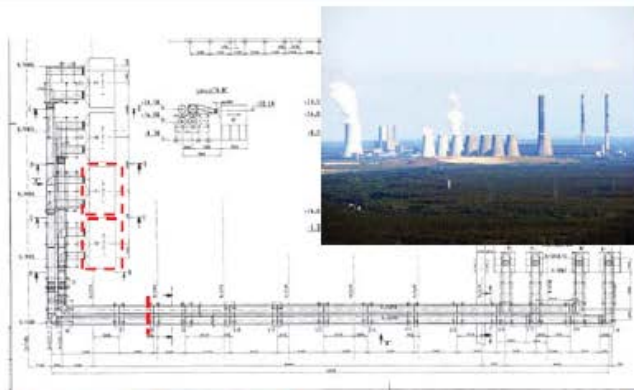

20/21. April 2015 Total DMO | 18ST Workshop Smoke Stack Measurement

13

**PROJECT DIRECT CO2 MONITORING
FLOW MEASUREMENT**



- Installation FLOWSIC100:
 - Target uncertainty (as found): $U_{CO_2} \leq \pm 1.0\%$
 - 2-path system
 - 60° path angle
 - Chordal layout, mid radius position
- Upstream of the flue gas scrubber
 - T = 165°C (330°F)
 - Inner diameter 6200mm (20.34ft)
 - approx. 5D downstream of a 90°-bend with guiding plates
- Validation by
 - an extended measurement traverse at real conditions
 - Comparison with thermo-dynamic model calculation

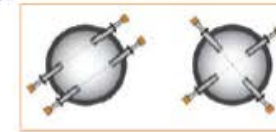

20/21. April 2015 Total DMO | 18ST Workshop Smoke Stack Measurement

14

PROJECT DIRECT CO2 MONITORING
ADJUSTMENT TIME MEASUREMENT



Zero flow check and SOS-check
Each device passed a zero-flow and a speed of sound check to reduce the manufacturing uncertainty



	U (k=2)
Time difference / μ s	0.5
Time absolute / μ s	2.8

PROJECT DIRECT CO2 MONITORING
GEOMETRY PARAMETER



- 3D laser scanner on site for precise measurement of
 - Diameter.
 - Path length and
 - Path angle

Parameter (N2)	value	u
Radius / mm	3102	7
Path length 1 / mm	6135	5
Path length 2 / mm	6177	5
Path angle 1 / °	57.68	0.1
Path angle 2 / °	57.63	0.1

u.1% error @ u. path angle \rightarrow u.3% velocity error

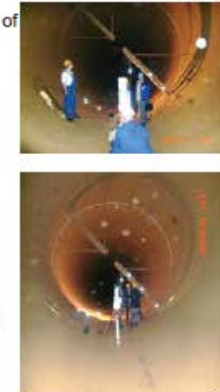

PROJECT DIRECT CO2 MONITORING
UNCERTAINTY CONTRIBUTIONS

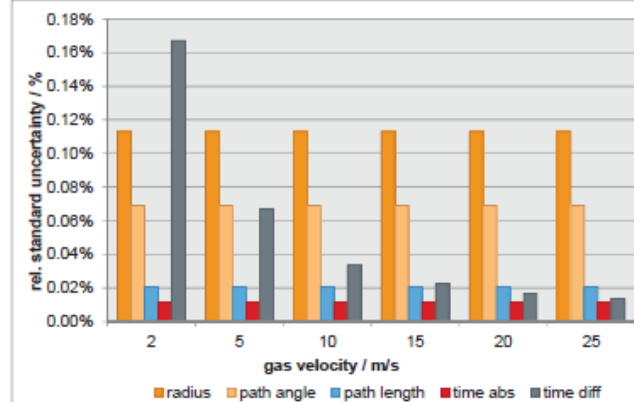

PROJECT DIRECT CO2 MONITORING
COMPUTATIONAL FLUID DYNAMICS



- Virtual adjustment: theoretically defined calibration function based on CFD calculations
- „Virtual calibration“ of the flow meter $k = m \cdot x + n$
Most conservative estimation of the flow profile $\pm 0.6\%$

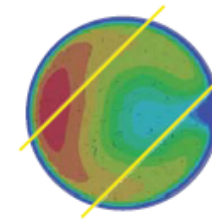

PROJECT DIRECT CO2 MONITORING
UNCERTAINTY CONTRIBUTION

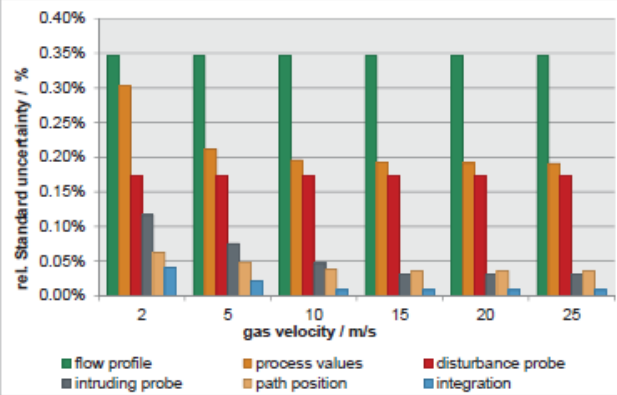

20.01. April 2015 Toralf Dietz | NEST Workshop Smoke Stack Measurement

19

PROJECT DIRECT CO2 MONITORING
EXPECTED UNCERTAINTY FLOW MEASUREMENT

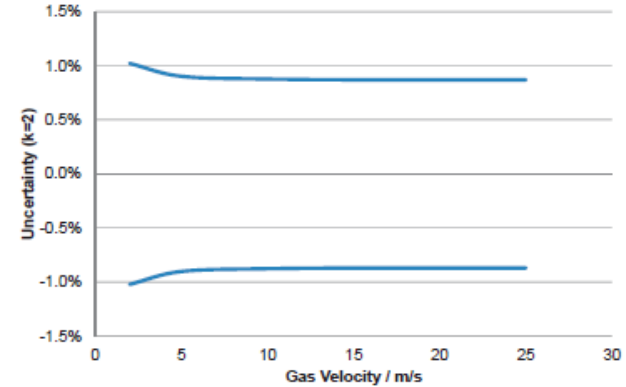

20.01. April 2015 Toralf Dietz | NEST Workshop Smoke Stack Measurement

20

PROJECT DIRECT CO2 MONITORING



(1) continuous thermo-dynamic calculation

- Process measurement
- Model of the thermodynamic cycle

(2) Mass balance analysis

- Mass of burned coal
- Chemical analysis the coal

(3) extended traverse test measure

- Acceptance inspection

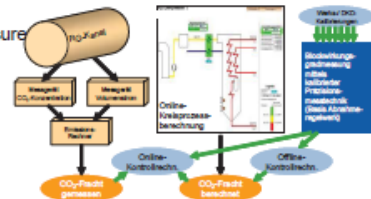

20.01. April 2015 Toralf Dietz | NEST Workshop Smoke Stack Measurement

21

THERMODYNAMIC MODEL CALCULATION
UNIT N1



- Average deviation $\Delta = 0.1\%$
- sigma: $\sigma = \pm 1.4\%$

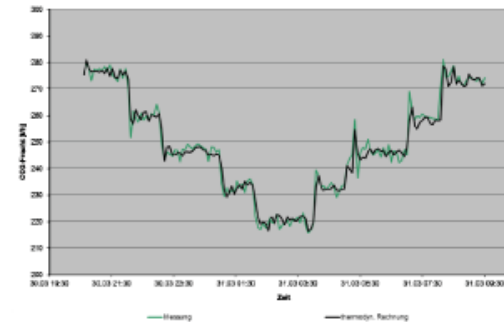

20.01. April 2015 Toralf Dietz | NEST Workshop Smoke Stack Measurement

22

THERMODYNAMIC MODEL CALCULATION UNIT N2



- Average deviation: $\Delta = -1.85\%$
- Sigma: $\sigma = \pm 1.1\%$

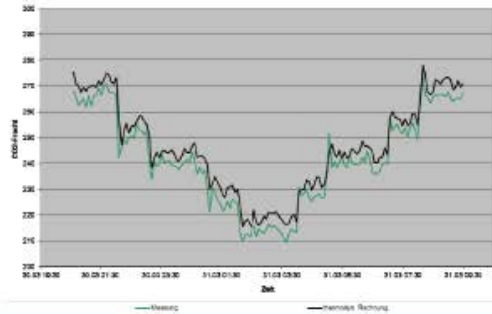

26.01. April 2016 Total Data | NEST Workshop Smoke Stack Measurement

33

THERMODYNAMIC MODEL CALCULATION UNIT P1



- Average deviation: $\Delta = 0.81\%$
- Sigma: $\sigma = \pm 1.0\%$

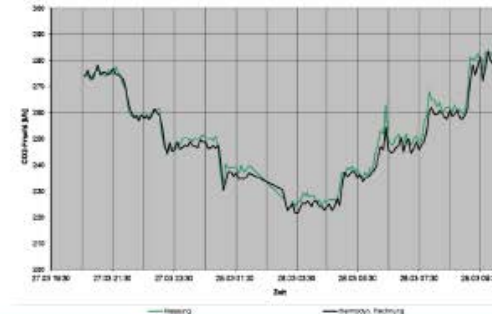

26.01. April 2016 Total Data | NEST Workshop Smoke Stack Measurement

34

THERMODYNAMIC MODEL CALCULATION UNIT P2



- Average deviation: $\Delta = 0.49\%$
- Sigma: $\sigma = \pm 1.0\%$

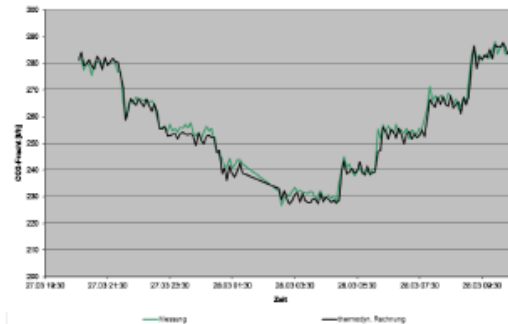

26.01. April 2016 Total Data | NEST Workshop Smoke Stack Measurement

35

RESULTS TOTAL CO2 MASS DIFFERENCES



method	Period	Unit N1	Unit N2	Unit P1	Unit P2
Total mass balance (U: 1.5%)	2 month	0.80%			
Thermo dynamic model calculation (U: 1.5%)	1 st month	-0.10%	1.85%	0.81%	0.49%
	2 nd month	0.50%	2.50%	1.20%	0.50%
Extended Traverse (U: 1.3 .. 2.2%)	Single test	-0.14%	1.86%	0.75%	0.47%

26.01. April 2016 Total Data | NEST Workshop Smoke Stack Measurement

36

- CEMS:
 - ▶ Measurement uncertainty of better than 1.5% is realistic for direct CO₂ monitoring
 - ▶ Verification uncertainty is at the same level!

- Recommendations for the Ultrasonic flow meter
 - ▶ Install with max. possible straight upstream length
 - ▶ Reduce the uncertainty by multi path layout (≥ 2path)
 - ▶ Use CFD analysis
 - to find an optimized path layout (if you have the freedom)
 - And/or calculate a "dry" calibration function
 - ▶ Do precise geometry measurement, especially
 - Path angle
 - Diameter

7.3.3 Practical Experience with CEMS Measurements

Donald Giel (Teledyne)

Session: CEMS and RATA Measurements

An overview of the practical application of ultrasonic flow meters for CEMS flow measurements is presented. Knowledge from practical experience on the challenges associated with making reliable, believable, and continuous flow measurements utilizing ultrasonic flow technology in large utility smokestack environments will be shared. Discussions will address instrument design features to maximize system uptime while minimizing the effects of the process conditions on the hardware.

Practical Experience with CEMS Measurement

Challenges Associated with making:

Reliable
Believable
CONTINUOUS

Flow Measurements in Large Utility Stacks

Don Giel

Teledyne Monitor Labs, Inc.



Ultrasonic Flow Monitor



Overview

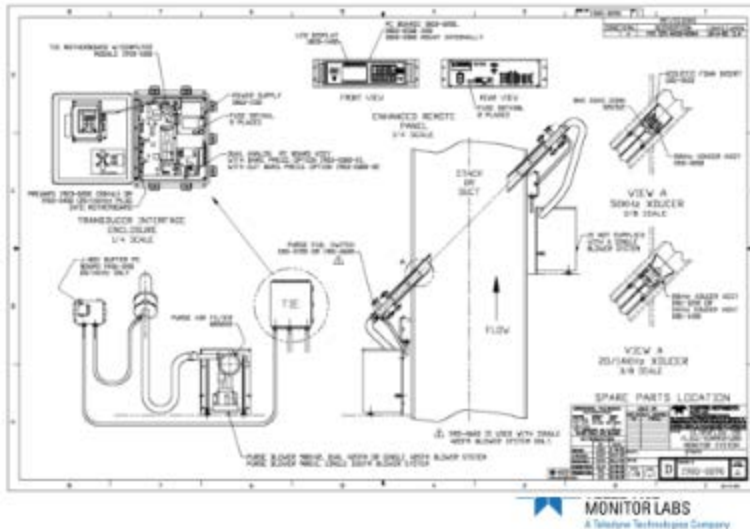

• What is an Ultrasonic Flow Monitor?

- It is a device that measures velocity based on the time-of-flight of signals t_1, t_2
- By determining t_1, t_2 , the monitor calculates velocity, volumetric flow and temperature

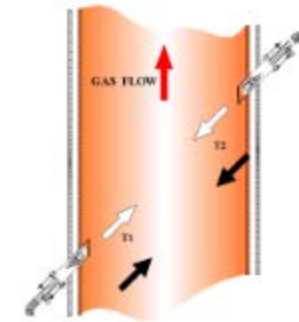

Stack Geometry

- L = Pathlength Transducer to Transducer
- H = Offset
- Area = Cross Sectional Area
- θ = Angle; $< 45^\circ$

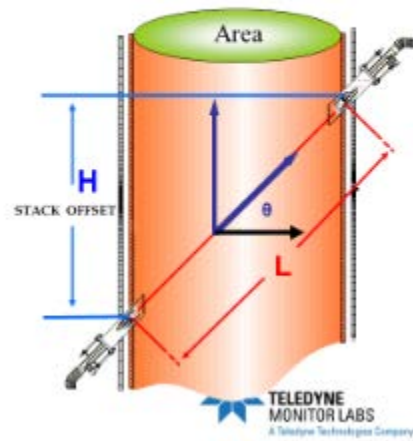

RELIABILITY CONCERNS

Utility smokestacks are harsh environments:

- Hot /Dry scrubbed or unscrubbed stacks
- Cool/Wet scrubbed stacks
- Corrosive gases present (SO_2)
- THEY ARE BIG.....diameter & height



Limitations of Ultrasonic Flow

- Typical Installation:
 - $\theta \geq 45^\circ$ angle but depends on:
 - pitch angle
 - # diameters down
 - # flues feeding the stack
 - Gas temperature
 - Gas velocity
 - Need Vertical Offset (H) to be No Less Than 4-5 Ft.
 - Max. Temp 850°F
 - Min. Diameter 3 Ft.
 - Max Diameter 45 Ft.

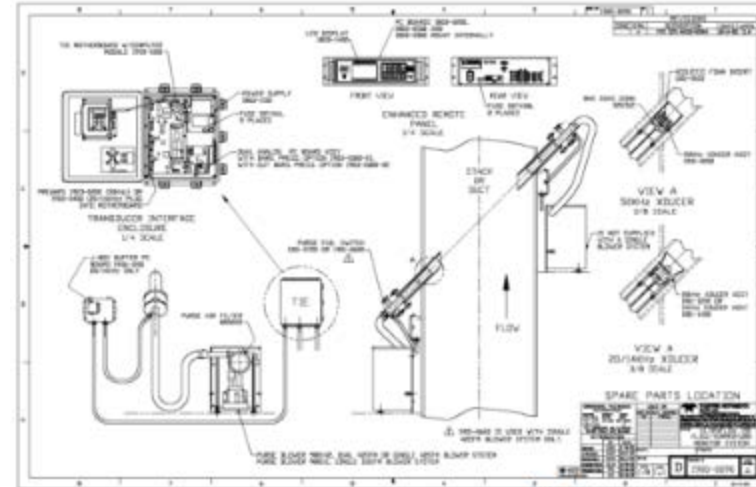
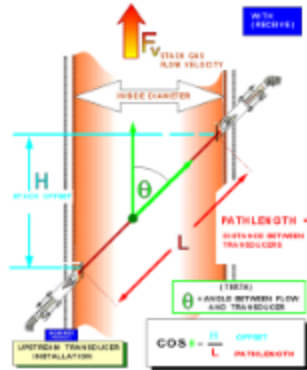

Typical Transducer Installation

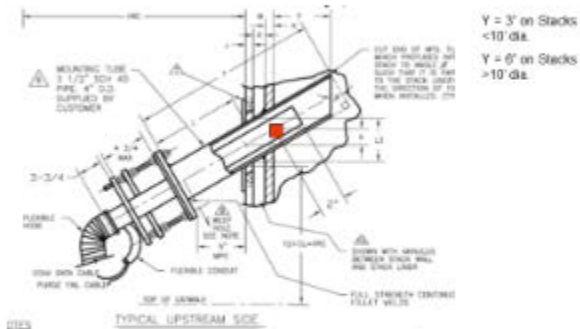

Transducer Types

- Short Range
 - 50Khz Electrostatic
- Long Range
 - 20Khz Piezo Electric
- Extended Long Range
 - 14Khz Piezo Electric
- Select based on stack dia., max temp, and max velocity
- Lower Frequency Provides MORE Power



Ultrasonic Flow Monitor



Believable Concerns

Inherent accuracy of time-of-flight technology

Wall effects, Pitch, Swirl, Multiple Units feeding a common stack

RELATIVE Accuracy.....



Overview

• How Does the Ultrasonic flow monitor Work to Calculate Velocity ?

- Tone bursts (Sound) are transmitted from the upstream transducer to the downstream transducer and then visa versa
- Tone bursts are transmitted approximately every 30 milliseconds in this alternating fashion (33/sec)
- The number of tone bursts sent in each direction is programmable (response time <5.0 seconds)
- The large # of tone bursts enhances accuracy, i.e., a larger statistical sample



Ultrasonic Flow Installation

Typical Installation

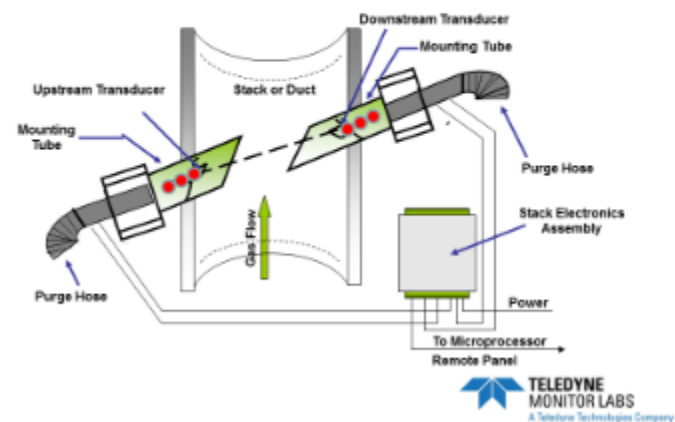

Time of Flight Principle

- What are the governing equations that model the time-of-flight of the tone bursts?

Velocity (With Gas Flow)

$$V_1 = C_s + F_v \cos \theta \quad (\text{added velocity})$$

Velocity (Against Gas Flow)

$$V_2 = C_s - F_v \cos \theta \quad (\text{subtracted velocity})$$

- Where

- C_s is the speed of sound
- F_v is Nominal flow velocity up stack
- θ is the angle of installation

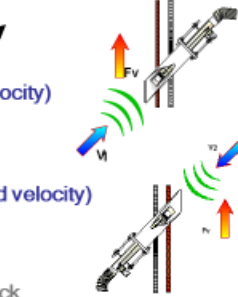

Velocity (Fv) Calculations

- C_s falls out of the subtracted equations
- Substitute Pathlength/Time for V₁ & V₂

$$F_v = \frac{L/t_1 - L/t_2}{2(\cos \theta)}$$

- Rearrange $F_v = \frac{L}{2(\cos \theta)} \left[\frac{t_2 - t_1}{t_1 t_2} \right]$



Believable Concerns

Statistical average over time (adjustable response time) leads to accurate flow measurement. Typically 1-5 minutes

Multiple transducers used for mitigation of flow anomalies in stacks (X-Pattern Config.)



Continuous Concerns

Non-Intrusive nature leads to long mean time before failure.

Mitigate the effects of condensing moisture in wet scrubbed stacks. "Weep Holes"

Blower Maintenance to maintain system performance



Field Experience with Ultrasonic

Port Alignment within 1-2 degrees

Consider a “Link-Rod” assembly for large annulus spaces.

Error on the side of a “larger than needed” flow port. Inserts are available!



Field Experience with Ultrasonic

Temperature and pressure will be needed for SCFM calculation. From the monitor or from external devices/inputs.

Safe and accessible mounting locations with “decent” air available for blower intakes.



7.3.4 Overview of ASTM D7036: A Quality Management Standard for Emission Testing

David Elam (TRC Environmental Corporation and Stack Testing Accreditation Council)

Session: CEMS and RATA Measurements

Emission testing remains one of the most challenging environmental measurement disciplines. A successful emission test program requires a solid understanding of test program objectives and the proper combination of test methodology, expertise, process operations, and often, regulatory agency coordination. Because there are so many variables and potential sources of error, many emission testing programs are not properly completed or are completed at significant - and often unanticipated - expense. The good news is that the challenges associated with emission testing can be effectively managed with proper program design, planning, coordination, and implementation.

ASTM D7036, Standard Practice for Competence of Air Emission Testing Bodies, is a quality management standard specifically designed for emission testing. ASTM D7036 provides the structure under which an Air Emission Testing Body (AETB) can deploy a process-based management system that addresses the challenges of emission testing. This presentation provides background information on process-based management systems, introduces ASTM D7036 with an emphasis on its application to process-based management, and highlight the relevance of ASTM D7036 to greenhouse gas measurement programs.



Overview of ASTM D7036: A Quality Management Standard for Emission Testing

David Elam, TRC Environmental

NIST Workshop
Measurement Challenges and Metrology for Monitoring CO₂ Emissions from Smokestacks
Gaithersburg, MD
April 20, 2015

Presentation Will Cover Three Areas

1. A review of process based management standards
2. An introduction to ASTM D7036
3. An overview of the ASTM D7036 Accreditation Process

Standards Level the Field

ISO/IEC Guide 2: 1996 defines a standard as:

a document, established by consensus and approved by a recognized body, that provides for common and repeated use, rules, guidelines or characteristics for activities or their results aimed at the achievement of the optimum degree of order in a given context.

3

Standards Provide Known Benefits

From the 1991 Annual Report of ASTM:

"Standards are a vehicle of communication for producers and users. They serve as a common language, defining quality and establishing safety criteria.

Costs are lower if procedures are standardized. Training is simplified. And consumers accept products more readily when they can be judged on intrinsic merit."

4

Standards Support Process-based Management

- Consensus-based standards:
 - reflect the input of a broad cross-section and establish a common denominator.
 - rarely define specific process requirements – instead they address expected involvement or outcomes.
 - are adaptable to reflect the business needs of the organization.

5

The Quality Cycle is Central to Process-based Management

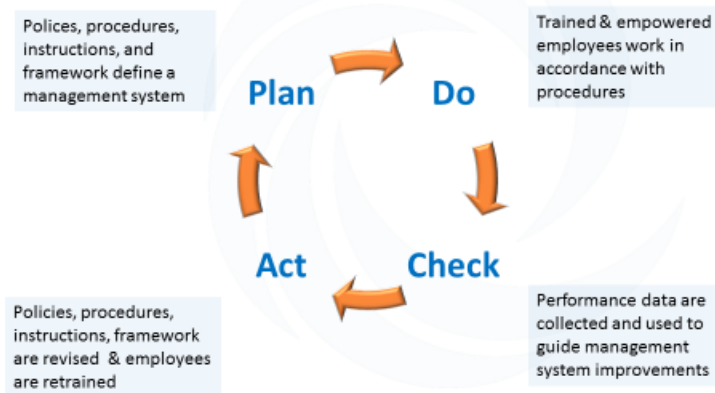

6

ASTM D7036 is a Process-based Management System for Emission Testing

An Overview of ASTM D7036	
Purpose	Enables Air Emission Testing Bodies (AETBs) to deliver data of defined and documented quality
Applicability	For use by firms making emission testing measurements. Required by USEPA for AETBs performing Part 75 tests.
History	First published in 2004. Modeled after ISO 17025.
Current Version	2012, but no material change from 2004 version
Accreditations	~ 5 Accredited AETBs, 18 Interim Accredited AETBS
Benefits	Ability to perform Part 75 work. Excellent platform for AETBs involved in other ISO 17025-based standards. Consistent, predictable delivery of services. A management standard without scope limitations.
Criticisms	Adoption expense, accreditation expense, "won't change data quality," just a "paper exercise."

7

Six Key Terms are Essential for Understanding ASTM D7036 (1/3)

- **Air Emission Testing**
 - Stationary source sampling and analysis, *exclusive* of fuel sampling, visible emissions testing, and daily operation and maintenance of continuous emission monitoring systems (CEMS)
- **Air Emission Testing Body (AETB)**
 - A company or other entity that conducts air emission testing. The AETB must conform to ASTM D7036.
- **Approved Test Protocol**
 - An approved test plan. Required for all projects.

8

Six Key Terms are Essential for Understanding ASTM D7036 (2/3)

- **Performance Data**
 - Data generated, or collected, or both by the AETB indicating conformance with the standard
 - Feedback from observers or customers
 - Internal and external audit results
 - Proficiency testing results
 - Any other data that provides objective documentation of AETB data quality

9

Six Key Terms are Essential for Understanding ASTM D7036 (3/3)

- **Qualification Exam**
 - A test, internal or external, used to evaluate the knowledge of an individual to become qualified.
- **Qualified Individual (QI)**
 - Experience, at least 10 tests for which they are seeking qualification or at least 1 year of general emission testing experience.
 - Exam, internal ok but external must be used if available.
 - Some confusion with Qualified Source Testing Individual (QSTI).

10

Five Elements Define ASTM D7036 Conformance

1. The AETB must have a Quality Manual (QM) that addresses requirements of ASTM D7036
2. The AETB must operate with prescribed functions
 - Technical Manager
 - Quality Manager
 - Qualified Individual
3. Test Plans are required for all projects
4. The AETB must conduct annual internal audits
5. Management must affirm that each test program conforms to ASTM D7036

11

The Qualified Individual is Central to ASTM D7036 Implementation

The Qualified Individual:

- Is qualified by both experience and method-specific examination
- Must oversee tests performed by the AETB
- Must sign a statement agreeing that all overseen tests conform the AETB's Quality Manual and ASTM D7036 in **all** respects

12

A Test Plan Is Mandatory and Must Address Minimum Requirements

- Objectives and Summary of Test Program
- Source Information
- Test Matrix
- Sampling Locations
- Test Methods, Number of Runs, Run Duration
- Process Data
- QC Procedures & Audits
- Reporting Format, Units
- Plant Entry and Safety
- Personnel Responsibilities
- Tentative Test Schedule

13

Why is Test Plan Mandatory?

- Primary source of testing and QC procedures for a test project
- Test plan, along with QM, forms the basis for a field audit
- **As essential to ASTM D7036 conformance as test program oversight by a Qualified Individual**
- *But ASTM D7036 defines content requirements, not form. A test plan/protocol can take any form as long as content requirements are satisfied.*

14

The Accreditation Process ^(1/2)

- The Stack Testing Accreditation Council (STAC) began accrediting AETBs in 2007
- Process involved:
 - Submission of an application with fee
 - Submission of a checklist
 - Submission of a Quality Manual
 - A two-part assessment process:
 - Structural – Are the proper management system components in place?
 - Functional – Is the management system being properly implemented?
- Process evolved slowly

15

The Accreditation Process ^(2/2)

- STAC signed an MOU with A2LA in 2014.
- A2LA manages the assessment process
- Importantly, A2LA conforms to ISO 17011, a standard applicable to “Accreditation Bodies.”
- A2LA and STAC jointly issue certificate of accreditation

16

ASTM D7036 and Greenhouse Gas Management

- Process based management standards rely on systems that produce defined results
- ASTM D7036 is a management standard applicable to emission testing
- Greenhouse gas (GHG) management will rely on emission testing
- GHG management programs can benefit from the application of ASTM D7036

17

7.3.5 Volumetric Flow Measurements of Stationary Sources: Common Mistakes, Corrective Measures

Scott Swiggard (Golden Specialty)

Session: CEMS and RATA Measurements

In stationary source testing accurate flow measurement is of very high importance. Inaccurate flow measurements lead to under or over reporting emissions, both bad for different reasons. In addition, performance of CEMS and CERMS (Continuous Emission Rate Monitoring System) is impacted by performance when either the Reference Method (Stack Tester) or the CERMS is reporting inaccurate data. The discussion will cover some common flow measurement mistakes, corrective actions, and other technical hurdles encountered.



Volumetric Flow Measurements of Stationary Sources: Common Mistakes, Corrective Measures

Presented By
Scott Swiggard, Ph.D., QSTI

Measurement Challenges and Metrology for Monitoring CO₂ Emissions from Smokestacks
NIST, Gaithersburg, MD
April 20 – 21, 2015

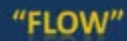

- **Stream flow - Stack flow (Emissions)**
The conglomeration of gases with varying chemical structures and masses homogeneously (most often) mixed, under pressure (+ or -) in a kinetic state flowing through a confined structure such as a duct, pipe or stack.



Flow Measurements

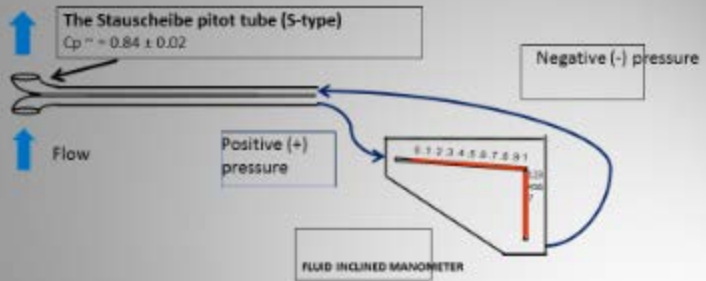

Standard Pitot

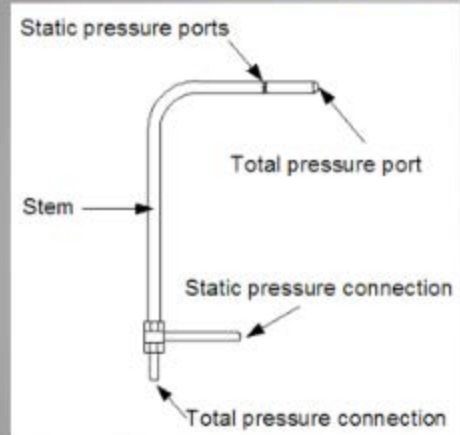

S-Type/Reverse/Stauscheibe



Inspection Tools



10" Liquid Manometer Block



Accuracy of Manometers

$$p = \frac{(g_t / g_o)(\rho_w - \rho_a)h}{\rho_o}$$

g_t = gravity at instrument location
 g_o = standard gravity (980.665 cm/sec²)
 ρ_a = density of air at observed temperature
 ρ_w = density of water at observed temperature
 ρ_o = density of water at standard temperature
 h = height of water column in inches

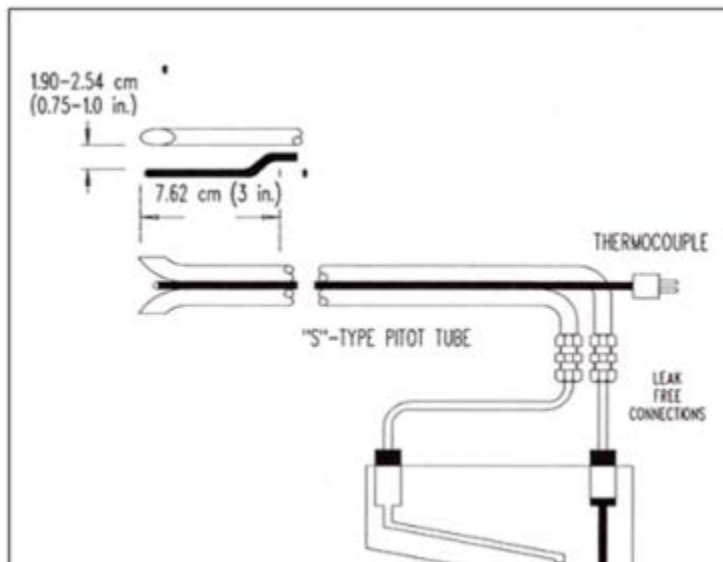

Secondary references or tools often used



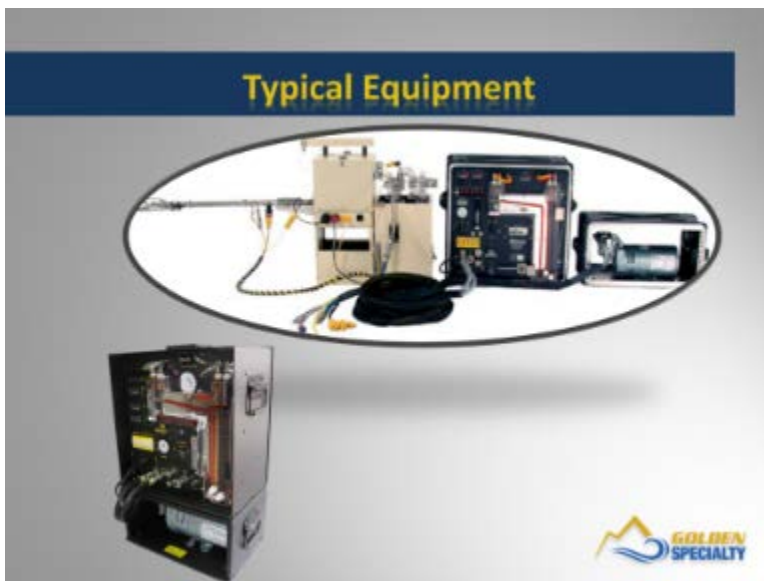
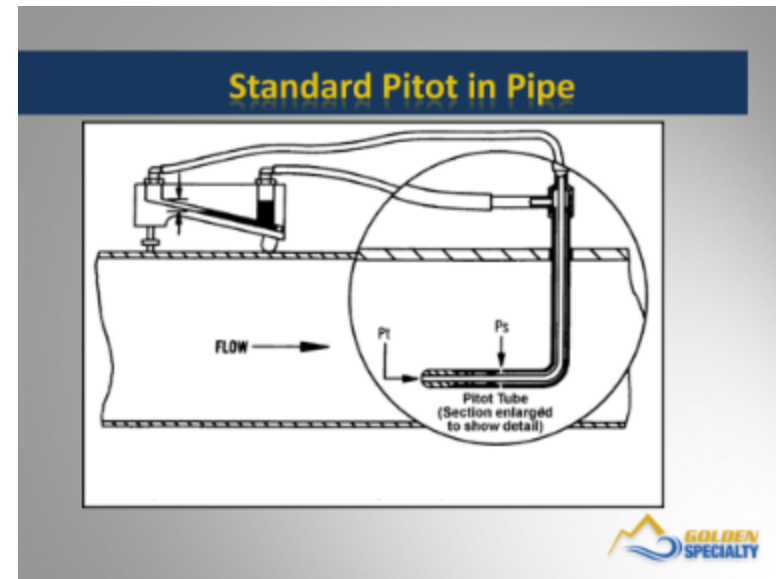
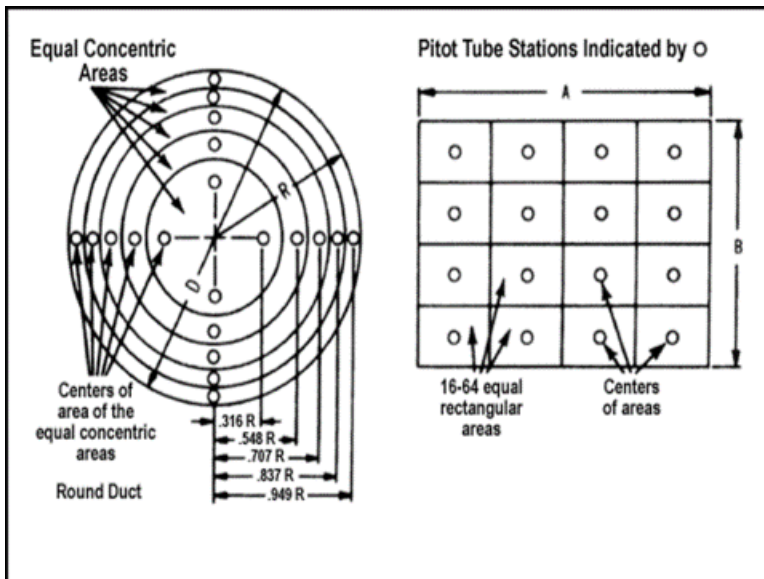

- ### Types of Errors
- Systematic
 - Random
 - Mistakes
- GOLDEN SPECIALTY

Problems/Mistakes/Errors

- Leaks and leak checks
- Calibrations: pitot, thermocouples, Fyrite, Barometer, tape measure
- Diameter measurements
- Operator error: eye position, leveling, consistent measurements, documentation, pinching of lines.
- Coefficient assignments: 0.84
- Flow turbulence and cyclonic
- Changing ID of stack due to material buildup
- Equations, units of measure, bad macro

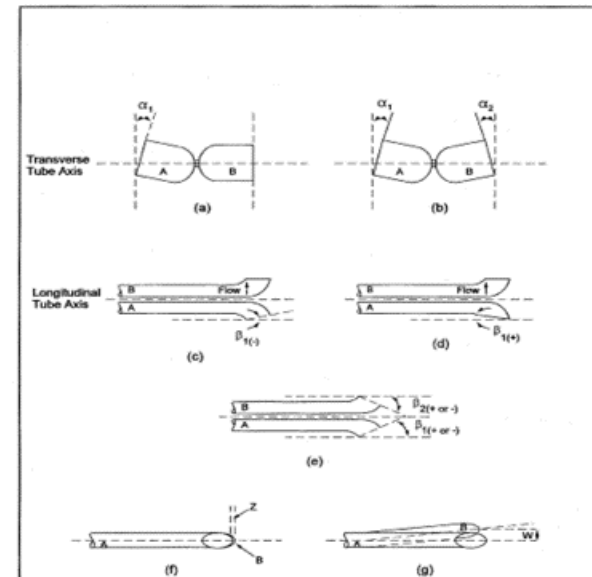

Thermocouple wires

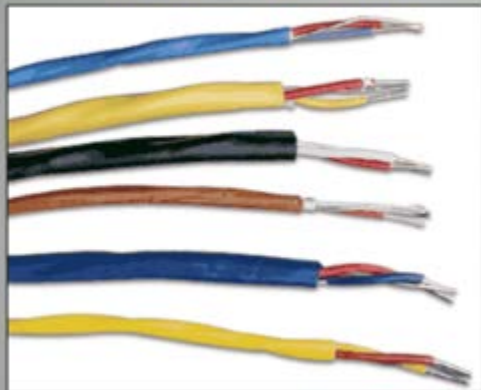

FLOW

Laminar – Cyclonic - Turbulent

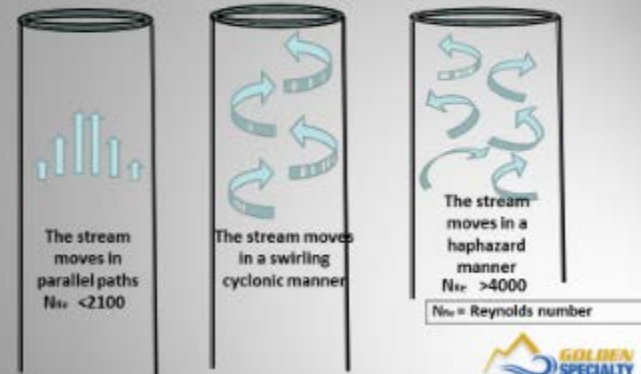

Stack buildup



Damaged/Dented/Properly Built



EPA METHOD 1

Method 1 states *“this method cannot be used when: (1) the flow is cyclonic or swirling...”*



EPA Method 1

Verification of the Absence of Cyclonic Flow

The Pitot is positioned at the first traverse point and rotated so the planes of the face openings are perpendicular to the direction of the flow. This is the 0° reference or null.



Cyclonic Flow May Exist

Tangential Entrance

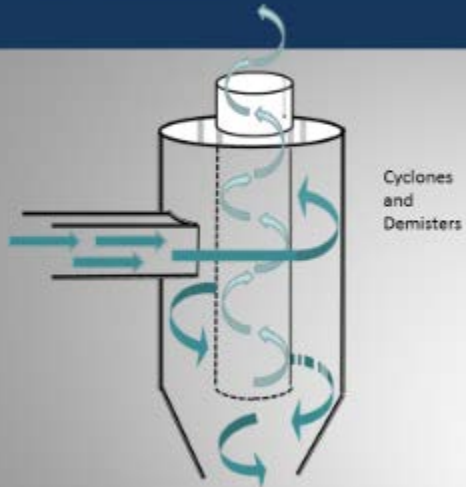
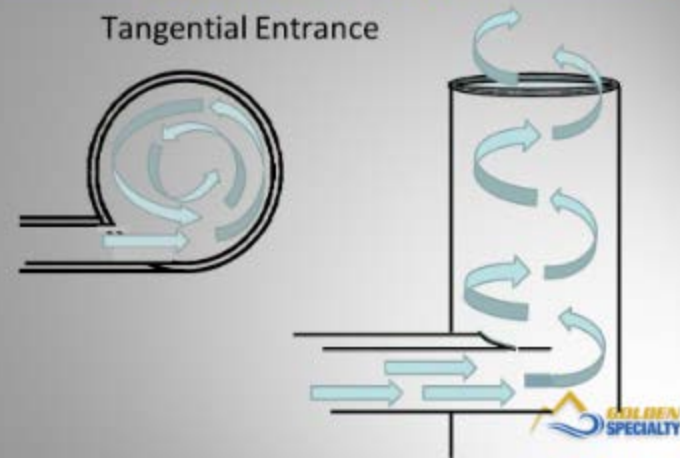

Source Modification

tangential Entrance to a tangential Exit

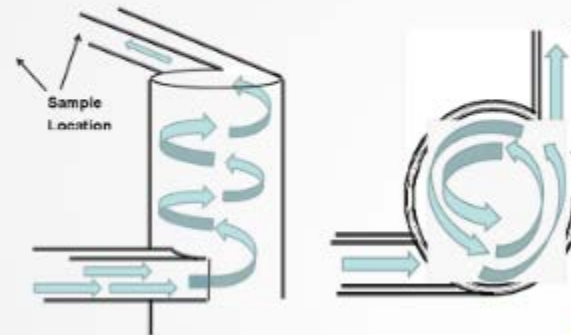

Source Modifications

Method 5D, 8.1.2 Straightening vanes

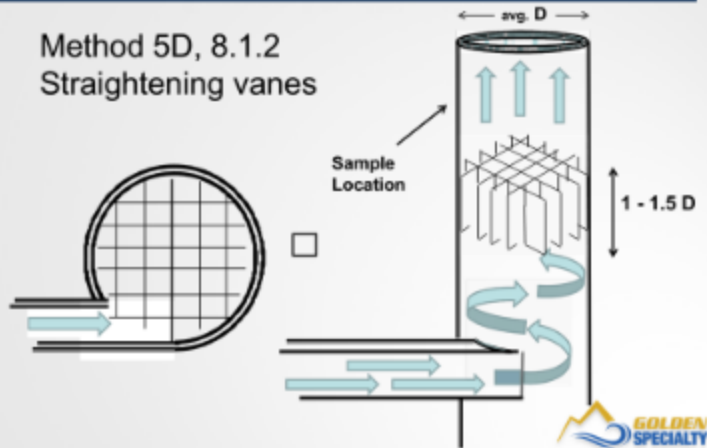

EPA Method 1

Verification of the Absence of Cyclonic Flow

After null angle has been applied to each traverse point, average the absolute values including any zero readings.

Example data set A	Example data set B	
pt. 0°	pt. 18°	Clockwise angles
pt. 8°	pt. 26°	
pt. 11°	pt. 34°	
pt. -10°	pt. -36°	Counter clockwise angles
pt. -7°	pt. -28°	
pt. -4°	pt. -20°	
Avg. 6.7°	Avg. 27°	
Acceptable	< Avg. 20° > unacceptable	



EPA Method 1

Section 11.4 Verification of the Absence of Cyclonic Flow

If the average angle is greater than twenty degrees (>20°), the flow condition in the stack is unacceptable for Method 1 flow measurements.

It is cyclonic!

An alternative methodology must be used subject to the approval of the Administrator.



Volumetric Flow

- Stack Diameter
- Velocity
- Stack Pressure
- Pitot Coefficient
- Stack Temperature
- Molecular Weight
- Moisture



Temperature Impact on CERMS

Flow measurements @ ~100F

RATA Calculations		
Ten - 21 minute average		
	N ₂ O (ppmv)	Flow (SCFM)
D-Bar=	9.49	1,448.8
Sigma-D=	4.74	2,025.0
CC=	3.39	1,448.59
RA(%)=	0.74%	1.89%

Flow measurements @ ~250F

RATA Calculations		
Ten - 21 minute average		
	N ₂ O (lb/hr)	Flow (SCFM)
D-Bar=	176.46	15,164.1
Sigma-D=	16.62	1,795.3
CC=	11.89	1,284.29
RA(%)=	11.73%	12.02%



S-Type Pitot paired analysis (ft/sec)

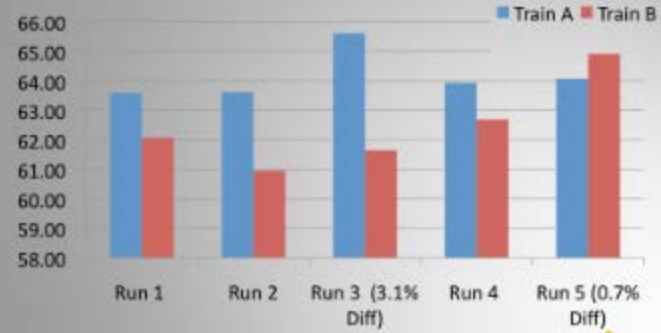

S-Type Pitot paired analysis Dry Standard Cubic Feet Minute

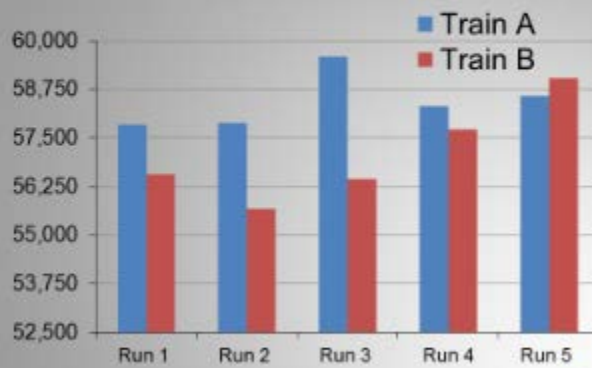

S-type pitot paired analysis

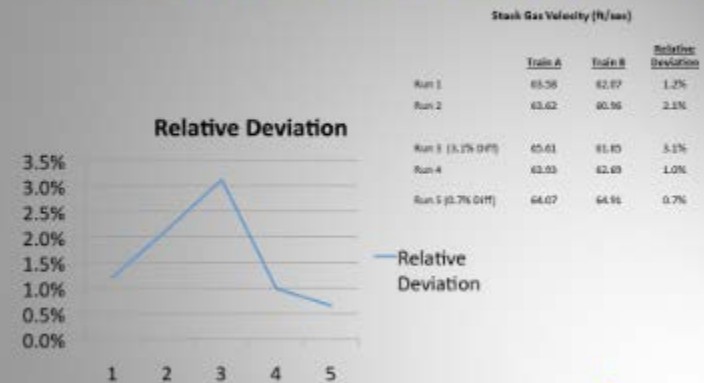

Same Source Temperature Measurement Error

Stack Temp ~100F

RATA Calculations		
Ten - 21 minute average		
	N ₂ O	Flow
	(ppmvd)	(SCFM)
D-Bar=	9.49	1,448.8
Sigma-D=	4.74	2,025.0
CC=	3.39	1,448.59
RA(%)=	0.74%	1.89%

Stack Temp ~250F

RATA Calculations		
Ten - 21 minute average		
	N ₂ O	Flow
	(b/hr)	(SCFM)
D-Bar=	176.46	15,164.1
Sigma-D=	16.62	1,795.3
CC=	11.89	1,284.29
RA(%)=	11.73%	12.02%



Low Flow Rate, RA S-Type Pitot

First time test (6-28-13) the MW lower and static pressure positive. The second time test (12-3-13), MW was higher and static pressure negative. Consistent RM data, obvious change to CERMS

RATA Calculations	
Nine - 21 minute average	
	Flow
	(ft/sec)
*Average RM Data	18.61
*Average CERMS Data	7.92
D-Bar=	10.69
Sigma-D=	0.71
CC=	0.55
RA=	80.40%

RATA Calculations	
Nine - 21 minute average	
	Flow
	(ft/sec)
*Average RM Data	19.94
*Average CERMS Data	18.33
D-Bar=	1.61
Sigma-D=	0.37
CC=	0.29
RA=	9.52%



5 Hole Prism
Shaped with 4
foot Sheath





Ways to Improve Accuracy in Measurement

1. Make the measurement with an instrument that has the highest level of precision. The smaller the unit, or fraction of a unit, on the measuring device, the more precisely the device can measure. The precision of a measuring instrument is determined by the smallest unit to which it can measure.
2. Know your tools! Apply correct techniques when using the measuring instrument and reading the value measured. Avoid the error called "parallax" -- always take readings by looking straight down (or ahead) at the measuring device. Looking at the measuring device from a left or right angle will give an incorrect value.
3. Repeat the same measure several times to get a good average value.
4. Measure under controlled conditions. If the object you are measuring could change size depending upon climatic conditions (swell or shrink), be sure to measure it under the same conditions each time. This may apply to your measuring instruments as well.



7.3.6 Stack/Duct Flow Measurements – Tracer Gas Method ASTM E2029

Richard Grot (Lagus Applied Technology, Inc.)

Session: CEMS and RATA Measurements

The presentation discusses an alternative stack flow measurement technique, namely the tracer gas dilution method, which can be used to measure the mass flow in stacks and pipes. The underlying concept of the method is to release a well-characterized tracer gas in a duct or stack and to determine its airflow by measuring concentration across a cross section downstream from the injection site. In situations where traditional flow measurements cannot be conducted, due to hazards or obstructions, this method provides excellent measurements and serves as an effective compliance technique. In most situations it will provide a measurement with greater accuracy than other methods. The method is based on first principles (conservation of mass) and significant advantages are gained by use of this method over the more traditional Pitot tube Transverse Method. The tracer dilution method is independent of flow conditions such as angle, swirl, or turbulence. The measurement does not require gas composition nor density of measured flow stream. Furthermore, at standard conditions, the method does not require temperature, pressure, humidity, nor stack diameter which is typically a significant sources of error.

Stack Duct Flow Measurements

Tracer Gas Method ASTM E2029

Richard Grot, Lagus Applied Technology, Inc.

 LAGUS APPLIED TECHNOLOGY, INCORPORATED

Method for Tracer Duct Flow Measurement

- Inject tracer at a constant flow rate into a duct
- Downstream from the injection measure the tracer concentration at several points on the cross-section of the duct to determine if tracer is well mixed
- If tracer is well mixed, determine flow using the following equation.

 LAGUS APPLIED TECHNOLOGY, INCORPORATED

Equation for Flow

$$F = \frac{C_{inj} \cdot f_{inj}}{C_d - C_u}$$

where:

F is duct flow

C_{inj} is concentration of injection gas

f_{inj} is injection flow rate

C_d is average downstream concentration

C_u is average upstream concentration

Note: Units of F and f_{inj} must be the same
Units of all C's must be the same

 LAGUS APPLIED TECHNOLOGY, INCORPORATED

Methods to Achieve Mixing

- Inject as far upstream as possible
- Inject through air handlers
- Inject using a manifold at several points on the cross-section
- Have several bends and elbows between the inject location and the sample cross-section
- Add turbulators and other mixing devices

 LAGUS APPLIED TECHNOLOGY, INCORPORATED

Injection Manifold

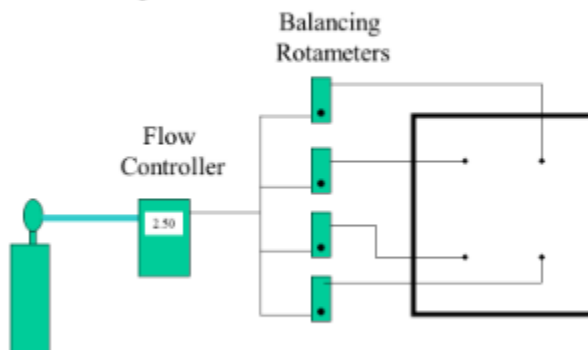

 LAGUS APPLIED TECHNOLOGY, INCORPORATED

ASTM E2029 Standard Sample Locations

Divide Duct Cross into Equal Area
Sample in center of each area and in center of duct

Minimum Number of Downstream Sample Locations

Duct Cross Sectional Area m ² (ft ²)	Number of Areas	Number of Samples
Less than 0.2 (2)	4	5
0.2 to 2.3 (2 to 25)	12	13
Greater than 2.3 (25)	20	21

Should use this table at least once to verify mixing
then sample from 4 equal areas and the center
(5 locations for repeated measurements)

 LAGUS APPLIED TECHNOLOGY, INCORPORATED

Advantages of Tracer Dilution Method for Flow Measurements

1. Based on first principles (conservation of mass) and does not require engineering assumptions
 2. Does not require the measurement of the area of the duct or stack
 3. Flows at standard conditions can be made without measurement of the temperature, pressure and humidity of the measured flow.
 4. Does not require that the composition of the measured gas flow be determined.
 5. Does not require that the density of the measured flow stream be determined.
 6. Does not require flow straightening.
 7. Independent of flow conditions - angle, swirl, turbulence, reversals
- Dry volumetric air flow can be determined by drying the air samples without measuring the water vapor concentration

 LAGUS APPLIED TECHNOLOGY, INCORPORATED

Steps in Calculations

- Calculate averages of downstream concentrations, upstream concentrations and injection flows
- Check mixing by calculating standard deviation of downstream concentration
- Correct injection flow averages for injection concentration
- Calculation flow rate using averages
- Perform error analysis

 LAGUS APPLIED TECHNOLOGY, INCORPORATED

Steps in Flow Measurements

- Calibrate Tracer Monitor
- Estimate injection flow rate
- Adjust mass flow controller to estimated injection flow
- Inject tracer for about 15 minutes
- Collect tracer samples and read injection flow
- Analyze samples using Tracer Monitor
- Perform Data Analysis

 LAGUS APPLIED TECHNOLOGY, INCORPORATED

Uncertainty Flow E2029

$$\frac{\partial_T F}{F}$$

The square root of the sum of the squares of the bias and the precision.

$$\frac{\partial_T F}{F} = \sqrt{\left(\frac{\Delta F}{F}\right)^2 + \left(\frac{\partial F}{F}\right)^2}$$

This is equivalent to the measurement uncertainty derived in ANSI PTC 19.1.

E2029 Error Analysis – Bias Error

The bias ΔF

$$\frac{\Delta F}{F} = \sqrt{\left(\frac{\Delta C_I}{C_I}\right)^2 + \left(\frac{\Delta F_I}{F_I}\right)^2 + \frac{(\Delta C_D)^2 + (\Delta C_U)^2}{(C_D - C_U)^2}}$$

ΔC_I is the uncertainty in the injection gas concentration

ΔF_I is the uncertainty in the injection flow rate

ΔC_D is calibration uncertainty in the downstream concentration

ΔC_U is calibration uncertainty in the upstream concentration

E2029 Precision Error

σF

$$\frac{\sigma F}{F} = t(N-1, 0.95) \sqrt{\frac{\sigma F_I^2}{(F_I)^2} + \frac{\sigma(C_D - C_U)^2}{(C_D - C_U)^2}}$$

$$\sigma F_I^2 = \frac{1}{N-1} \sum_{i=1}^N (F_i^i - F_I)^2$$

$$\sigma(C_D - C_U)^2 = \frac{1}{N-1} \sum_{i=1}^N (C_D^i - C_U^i - C_D + C_U)^2$$

$t(N-1, 0.95)$ is the two-sided confidence limits of the Student Distribution for N-1 and probability 0.95.

Symbols without superscript i are average value of quantity

Sample Flow Spreadsheet – page 1

FCC-Regenerator Air Flow										
Nov. 30, 1999										
Inj Conc					Meter Fact					
1.0320%					0.968353863					
Inj Flow					Gas Fuel Flow					
5.12 sccm(70F)					187331 sccm(88 F)					
% Var					Flow mscfd					
0.42%					269757 mscfd(88 F)					
Time Average					Avg Diff					
					% Var					
					0.60%					
Time Average					Avg					
					0.00824467					
Data					Avg Var					
					0.009456467					
start	run	end	Inj(Top)	Inj(Mid)	Inj(Bot)	GA	GA	Var	Inj Flow	Flow(88 F)
			ppb	ppb	ppb	ppb	ppb	ppb	sccm(70 F)	scfm
1	12:30	12:45	9.89	9.66	9.51	0.015	9.62	0.00824467	5.11	187452
2	12:45	13:00	9.79	9.64	9.44	0.008	9.59	1.10%	5.11	184175
3	13:15	13:30	9.75	9.64	9.59	0.044	9.66	0.69%	5.08	184742
4	13:30	13:45	9.60	9.76	9.44	0.006	9.66	1.67%	5.11	185931
5	13:45	14:00	9.78	9.58	9.65	0.028	9.68	0.93%	5.12	188141
6	14:15	14:30	9.57	9.45	9.34	0.000	9.45	0.99%	5.11	190092
7	14:30	14:45	9.88	9.77	9.49	0.030	9.65	1.21%	5.12	186556
8	14:45	15:00	9.65	9.72	9.57	0.024	9.65	0.64%	5.14	187365
9	15:15	15:30	9.67	9.69	9.41	0.000	9.59	1.33%	5.14	188498
10	15:30	15:45	9.57	9.56	9.47	0.011	9.54	0.52%	5.14	189457

Sample Flow Spreadsheet- page 2

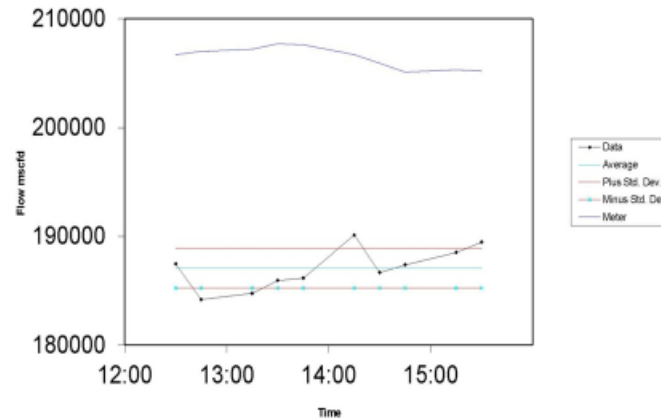

7.3.7 3D Pitot Tube Measurements and Calibration in the Wind Tunnel

Kyle Lee (ITRI, Taiwan)

Session: Pitot Probe Characterization and Calibration

Greenhouse gas emissions have been regarded as a global challenge and it is even more serious in the Asia Pacific region. Smokestack emissions are one of the main pollution sources and its flow measurements draw much attention due to the unstable flow conditions and complex gas composition. Pitot tubes have been widely used for flow measurements in the environmental analysis. However, the traditional pitot tubes (L type or S type) can only provide one-dimensional flow velocity and the measurement locations require considerable care. The U.S. EPA already announced that 3D pitot tubes (prism type, spherical type) can be used for three-dimensional swirl flow measurements in the smokestack and could provide more detailed flow information. Nevertheless, the calibration facility and procedures still need more studies in order to fulfill the standard traceability and uncertainty evaluation. Therefore, the Center for Measurement Standards started to design an automated 3D traverse system last year and installed it in the wind tunnel for pitot tubes calibration. After testing, the design has been proved to be feasible to operate in the test section of wind tunnel. The calibration can be performed with different angles in the air speed calibration system with relative expanded uncertainty of 0.5 %. The pitch and yaw angle range from -40 degrees to +40 degrees and -180 degrees to +180 degrees, respectively.

工業技術研究院
Industrial Technology
Research Institute

3D Pitot Tube Measurements and Calibration in the Wind Tunnel

Center for Measurement Standards
Industrial Technology Research Institute
Taiwan, R.O.C.

Hsin-Hung (Kyle) Lee

April 20, 2015

工業技術研究院
Industrial Technology
Research Institute

About ITRI

- Founded in 1973

Total Staff : 5,782	Total Patents : 16,732
Ph.D. : 1,295	Start-Ups : 171

About ITRI

- A not-for-profit non-government R&D organization

- To create economic value through innovation and technology R&D
- To spearhead the development of emerging new industry
- To enhance the competitiveness of Taiwanese industries in the global market



Contents

- Introduction
- Technology Needed for Smokestack Flow Measurements
- Characterization of Pitot Tubes
- Calibration Facilities
- Calibration Data Analysis
- Future Work

Technology Needed for Smokestack Flow Measurements



Touch panel manufacturers Waste incineration plants Semiconductor manufacturers

Technical challenges

- Swirl and inhomogeneous flow
- Complicated compositions
- Location of measurements
- Calibration of instruments

Characterization of Pitot Tubes

- Design of 3D pitot tubes

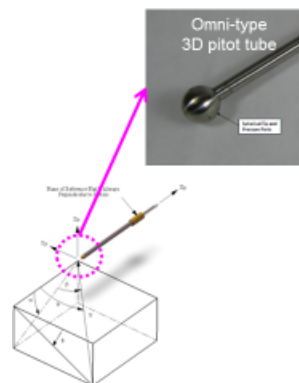

Geometry and Construction		Measurement Accuracy (w/Aeroprobe Calibration)	
Probe Geometry	Straight, L-Shaped	Flow Angles	< 1°
Number of Holes	12	Total Flow Velocity	< 1%*
Tip Geometry	Spherical	Required Auxiliary Data**	Reference Pressure, Total Temperature
Tip Diameter	6.35 mm, 9.53 mm	Flow Angle of Receptivity	120°
Material	All-Stainless Steel Construction	Calibration Flow Speeds	5 m/s to 315 m/s (Mach = 1.0)
Pneumatic Connection	Tygon R9603 Formulation, 1/32" ID, 3/32" OD Standard for Exit Tubing of 0.89 mm – 1.6 mm (0.035" – 0.063") OD.	Pressure Data Reduction	OmniPro Software
Mounting	Hex Prism (standard)	Frequency Response	Low, Best for Determining Time-Averaged Flows
Probe Reference	Flat on Hex Mount with "R"	Media	Non-Reactive Gases
Flow Temp. Limits	0°C – 150°C		*Utilizing 0.1% Accurate Pressure Sensors Properly Rated for Flow Speed **For Most Accurate Compressible P-V Reduction

Calibration Facilities

- Calibration system construction at CMS

3D Motion → 3D Measurements

3D Calibration is needed !!

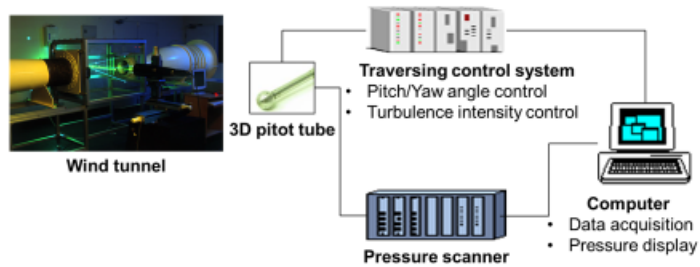

Copyright 2014 ITRI 工業技術研究院

Calibration Facilities

- Pressure measurements and calibration

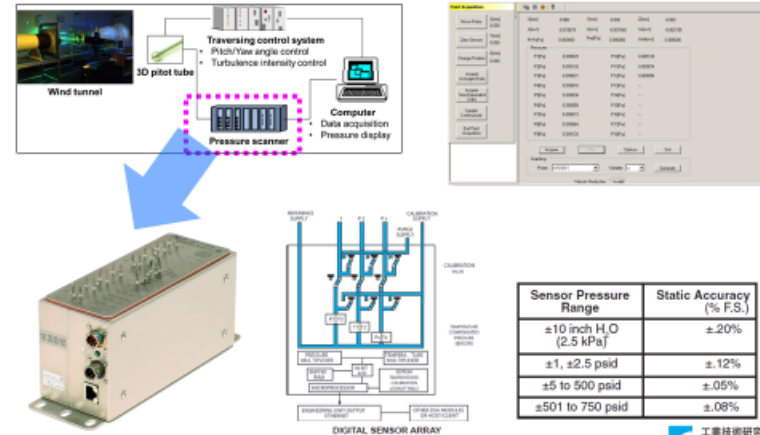

Copyright 2014 ITRI 工業技術研究院

8

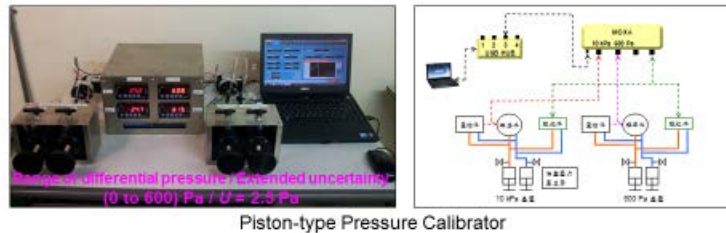

Copyright 2014 ITRI 工業技術研究院

9

Calibration Facilities

- Turbulence generation

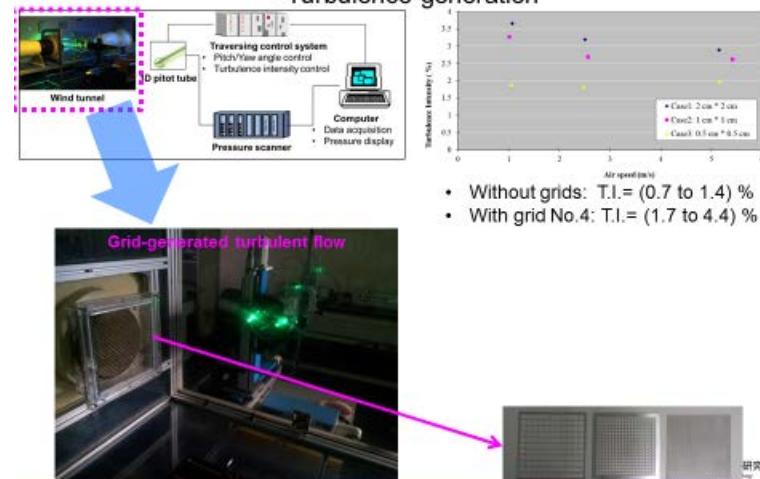

Copyright 2014 ITRI 工業技術研究院

Calibration Facilities

- Traverse stage

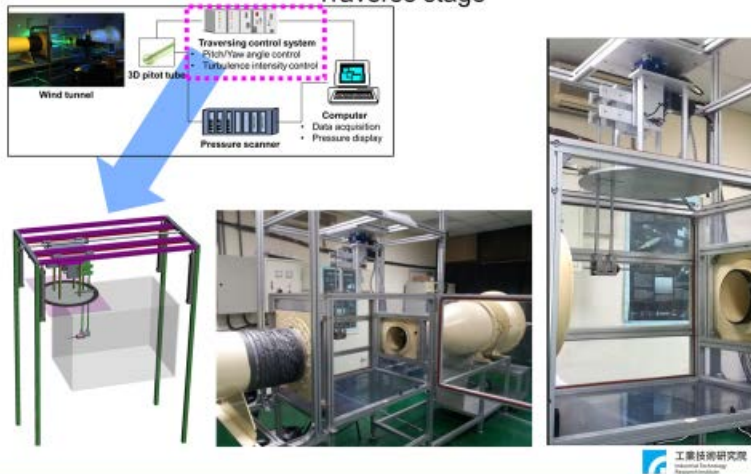

Copyright 2014 研創 工業技術研究院

Calibration Data Analysis

- Definition of pressure coefficients

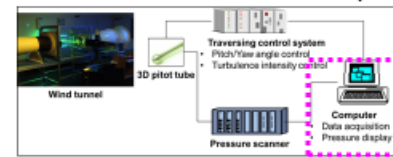

Input:

$$B_\alpha = \frac{P_4 - P_5}{Q'}, \quad B_\delta = \frac{P_1 - P_3}{Q'}$$

where $Q' = p_2 - 0.25 \times (p_1 + p_3 + p_4 + p_5)$.

Output:

$$\alpha, \delta, A_t = \frac{P_2 - P_t}{Q'}, \quad A_z = \frac{P_2 - P_z}{Q'}$$

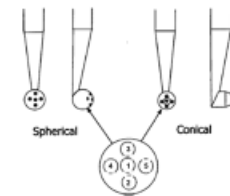

工業技術研究院
Industrial Technology
Research Institute

12

Calibration Data Analysis

- Nulling method

Step 1: Align the probe so that the center hole is pointing towards a reference position.

Step 2: Rotate probe until $P_2 = P_3$. This is the Yaw angle.

Step 3: Calculate Pitch Angle Pressure Coefficient $[(P_4 - P_5) / (P_1 - P_2)]$.

Step 4: Determine Pitch Angle.

Step 5: Determine Velocity Pressure Coefficient $[(P_t - P_s) / (P_1 - P_2)]$.

Step 6: Calculate Velocity pressure $(P_t - P_s)$.

Step 7: Determine Total Pressure Coefficient $[(P_1 - P_t) / (P_t - P_s)]$.

Step 8: Calculate $(P_1 - P_t)$ and obtain P_t .

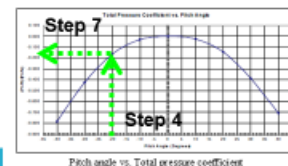
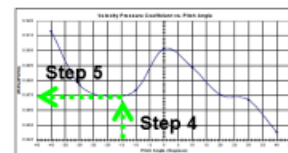
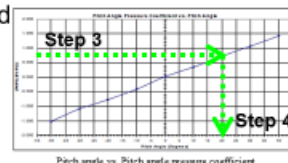

Copyright 2015 研創 工業技術研究院

Calibration Data Analysis

- Non-nulling method

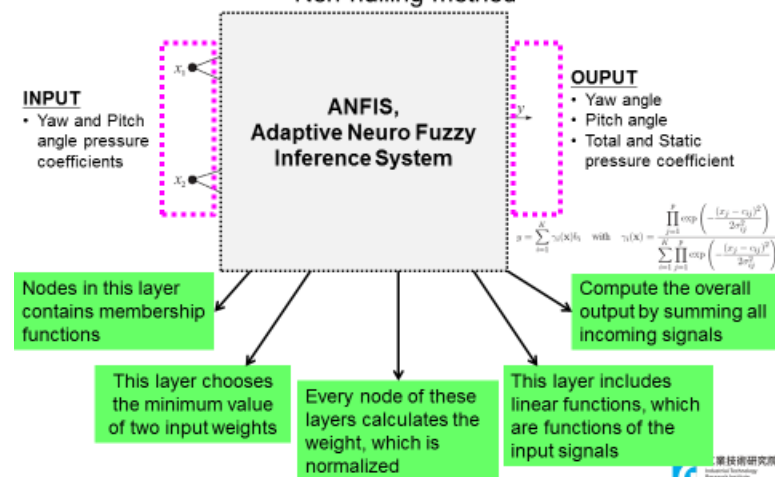

工業技術研究院
Industrial Technology
Research Institute

Copyright 2015 研創 工業技術研究院

Future Work

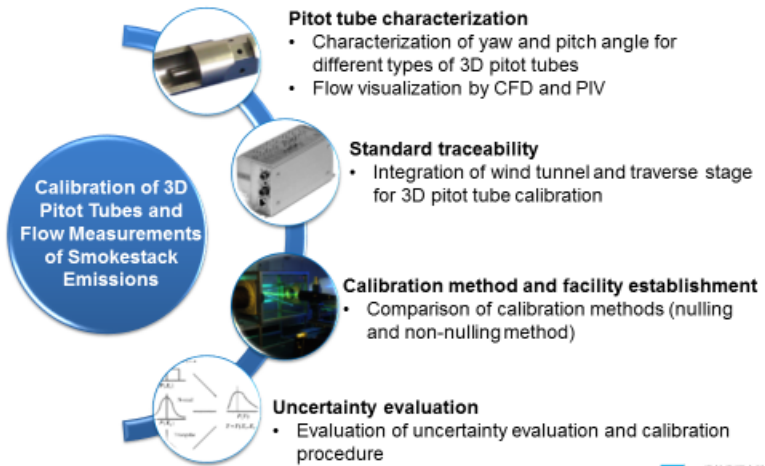

7.3.8 Experimental and Numerical Investigations of the Factors Affecting the S-type Pitot Tube Coefficients in GHG Emission Monitoring

Woong Kang (KRISS, Korea)

Session: Pitot Probe Characterization and Calibration

In greenhouse gas emission monitoring from industrial stacks, the most common device used to measure stack gas velocity is the S-type Pitot tube. Various factors such as the Reynolds number and misalignment of the installation angle can be additional error sources for the S-type Pitot tube coefficients due to harsh environments. Manufacturing quality of the S-type Pitot tube is also a factor affecting the measurement uncertainty of stack gas velocity. In the present study, wind tunnel experiments were conducted in the KRISS (Korea Research Institute of Standards and Science) standard air speed system to examine the effects of various factors on the S-type Pitot tube coefficients. Numerical simulations were also used to understand flow phenomena around the S-type Pitot tube in the presence of misalignment and distortion of the geometry.

Experimental and Numerical Investigations of the Factors Affecting the S-type Pitot Tube Coefficients in GHG Emission Monitoring

Woong KANG

Center for Fluid and Flow

Korea Research Institute of Standards and Science

Measurement Challenges and Metrology
for Monitoring CO₂ Emissions from Smokestacks

Korea GHG Inventory

- High proportion (90%) of greenhouse gas emissions arising from the energy and industrial fields such as heavy / petrochemical / semiconductor and power plant

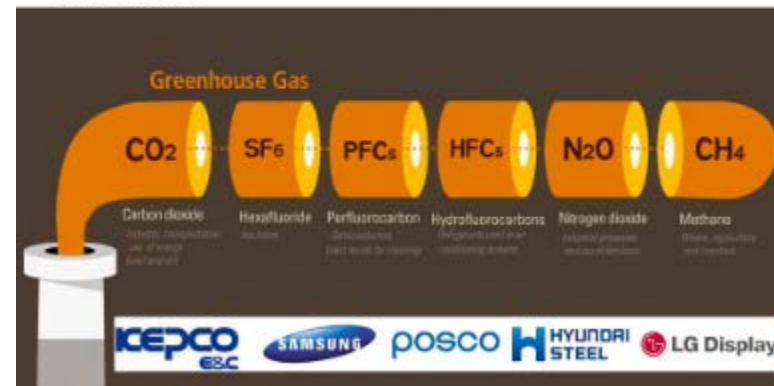

Korea Emission Trading Scheme

- Implementation with allocation of emission cap for each company in 2015
- To meet the cap of emissions, company with increasing emissions should buy emission allowance from other emission-reduced company

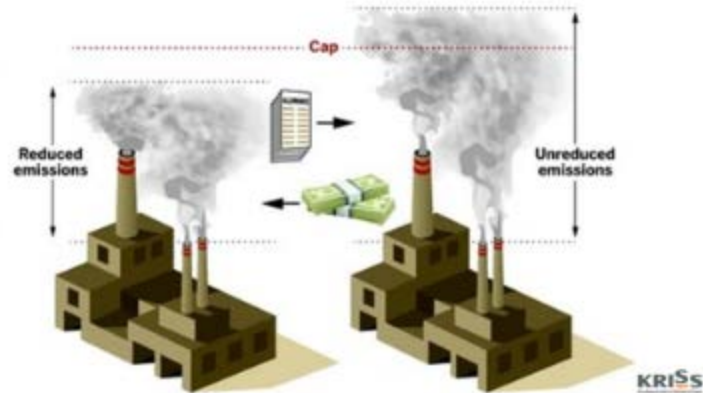

Continuous Emission Measurement

- Directly measure GHG emissions by monitoring concentrations and volumetric flow rate an exhaust gas
- Accurate and actual emissions measurements by U.S. EPA and Korea Ministry of Environment

$$E_{CEM} = \sum_{i=1}^N E_{5min,i} = \sum_{i=1}^N (\bar{C}_i \times Q_{5min,i} \times \frac{MW_{gas}}{22.4L})$$

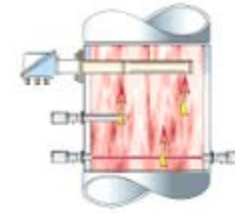

KRISs

Instruments for Stack Flow Velocity in KOREA

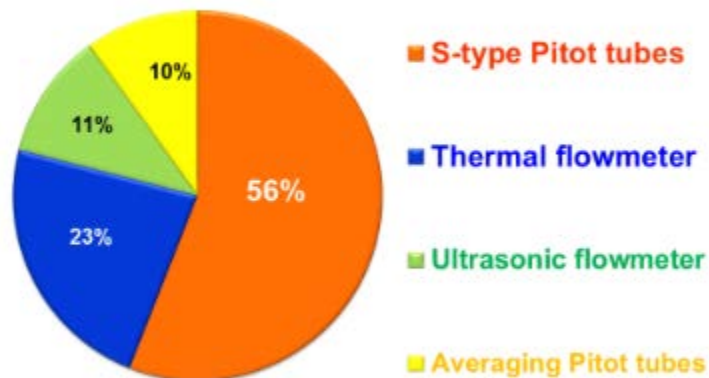

KRISs

S-Type Pitot tube

- Large pressure orifices($\Phi=5\sim 10\text{mm}$) & Strong tubes for high dust environments like industry stack (ISO 10780, KS M9429, EPA method2)
- Measurement differential pressure between an impact(total pressure) and wake orifice(static pressure) based on Bernoulli equation

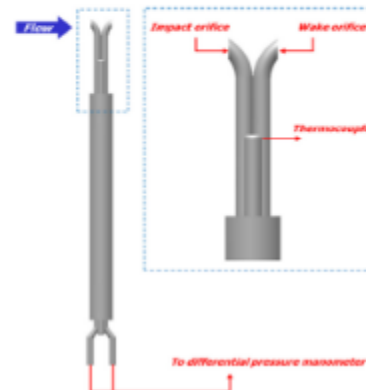

$$V = C_{p,s} \sqrt{\frac{2\Delta P}{\rho}}$$

V : flow velocity in the stack gas(m/s)
 $C_{p,s}$: S type Pitot tube coefficient
 ΔP : differential pressure between impact and wake orifice (Pa)
 ρ : density of the stack gas (kg/m^3)

KRISs

Calibration for S Pitot Tube Coefficient (C_p)

- Calibration against L-type Pitot tube in the wind tunnel of the national metrology institute or the accredited calibration laboratories.

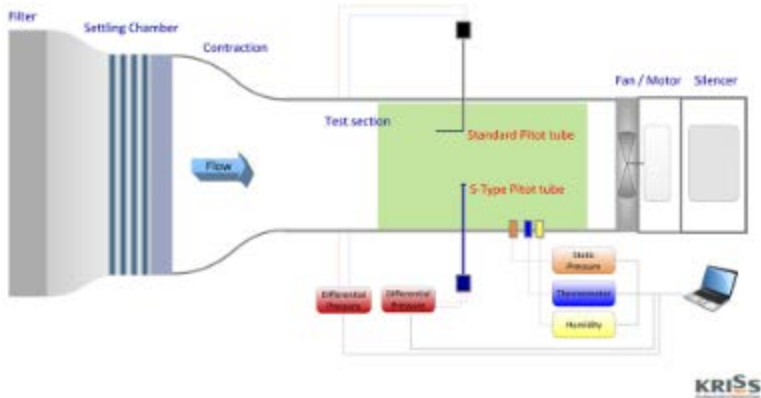

Calibration for S Pitot Tube Coefficient (C_p)

- Determination by comparing the differential pressure of standard pitot tube and S-type Pitot tube

$$C_{P,S-type} = C_{P,Std} \left(\frac{\Delta P_{Std}}{\Delta P_{S-type}} \right)$$

$C_{P,S-type}$: S Pitot tube coefficient
 $C_{P,Std}$: Standard Pitot tube coefficient
 ΔP_{S-type} : differential pressure of S Pitot tube
 ΔP_{Std} : differential pressure of Standard tube

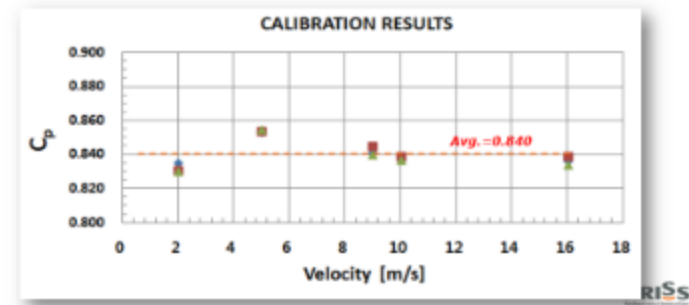

Velocity Measurements in the Stack

- As the diameter of stacks increases, the sampling traverse point for measuring velocity distributions in the stack should increase according to the ISO 10780 and EPA method.

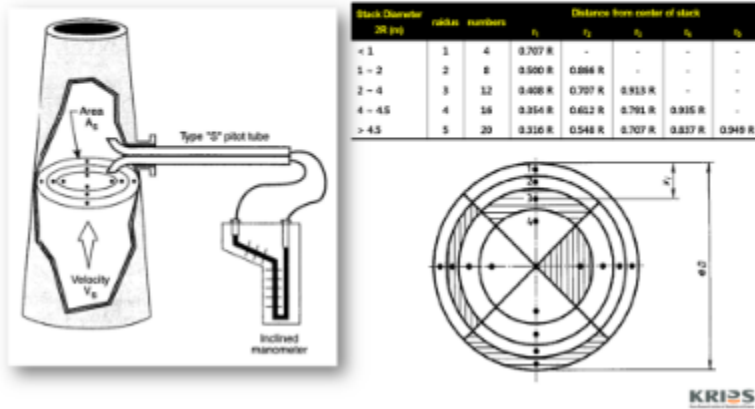

On-site Measurement



On-site Measurement

- S-type Pitot tube is usually installed and inserted in harsh environment such as tall stack height and high gas temperature



KRISs

On-site Measurement

- Difficult to observe the inside of the stack and verify the precise installation of the S-type Pitot tube



KRISs

What Happens Inside the Stack?

- Flow velocity of emission gas can be altered due to the unstable process in particular industrial condition of plant.
- Yaw angle misalignment can occur during installation of S-type Pitot tube from outside of the stack due to the difficulty of observation
- Pitch angle misalignment of S-type Pitot tube can result due to the deflection of the long S-type Pitot tube in large diameter stacks.

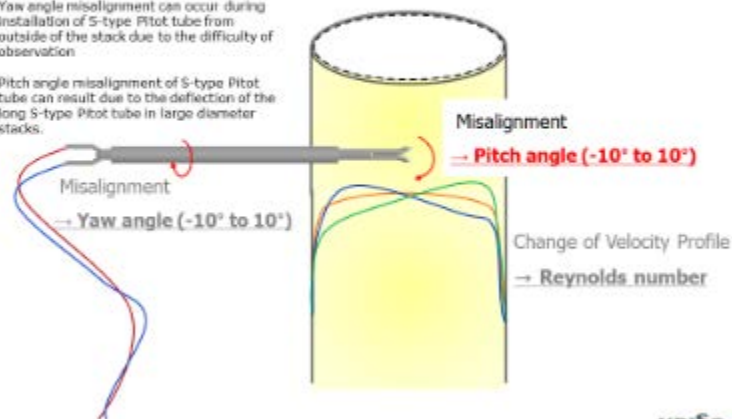

KRISs

Manufacture Quality

- The geometry of the S-type Pitot tube can be changed by the manufacturing quality of the manufacturer(company) due to not-strong regulation for standard geometry of S-type Pitot tube

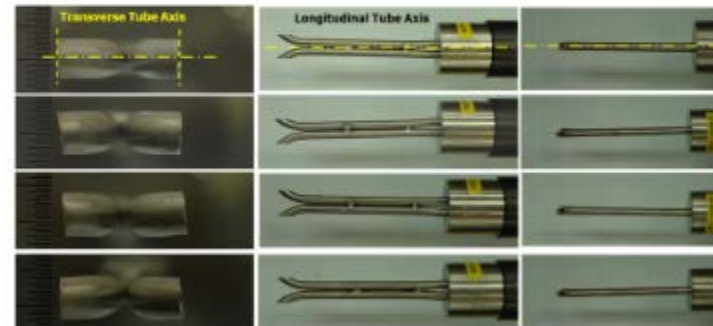

KRISs

Manufacture Quality

- Vollaro et al.(EPA, 1976) investigated the effect of impact opening misalignment on the S-type Pitot tube coefficient
 → 2% Error with impact opening misalignment

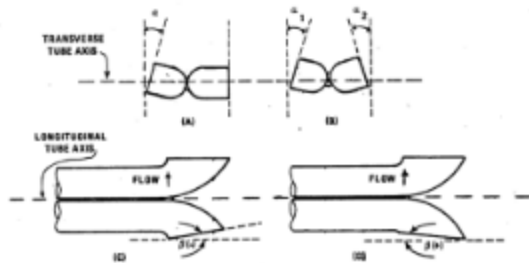

KRISs

Objective

- Evaluate the effect various factors on the S-type Pitot tube coefficients for accurate and reliable measurement GHG emission in industrial stack

1. Reynolds number effect

Velocity = 2 to 15 m/s

$Re_D = 3,000$ to $22,000$ (D : distance between two orifices)

2. Misalignment effect

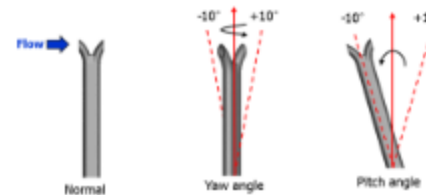

3. Manufacturing Quality

S-type Pitot tube calibration data of 4 major manufacturers in KOREA

KRISs

Experiment apparatus

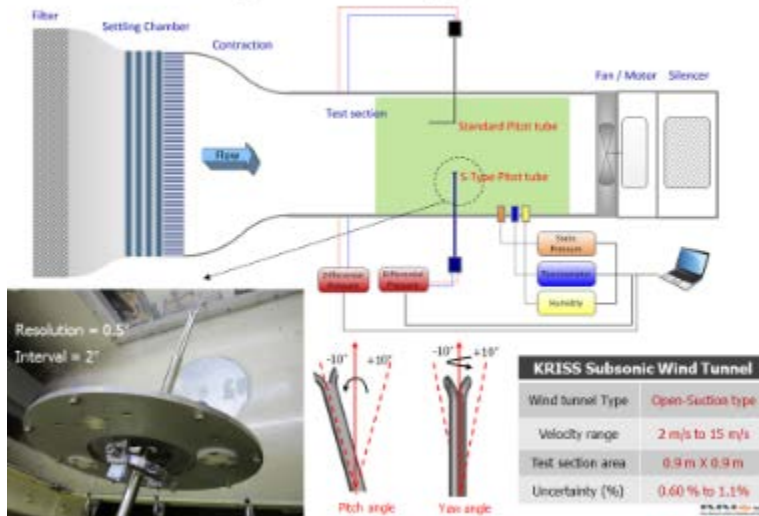

Numerical Simulation

- To understand flow phenomena around S-type Pitot tube when misalignment and distortion of geometries were present

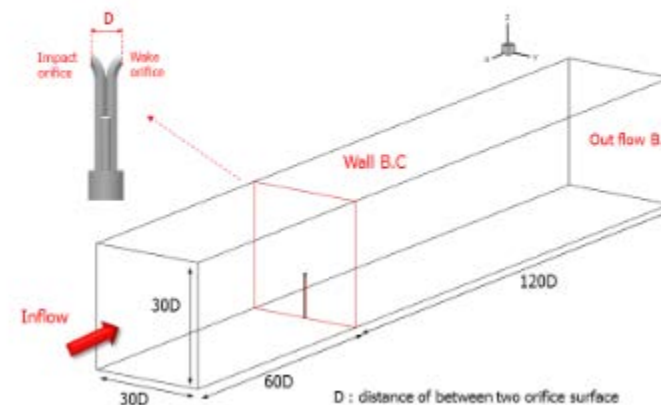

ISs

Numerical Simulation

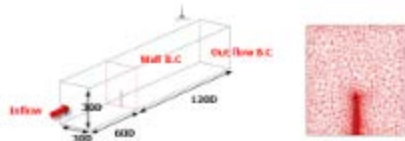

Numerical Method	
Equation	3-D Incompressible Navier-Stokes Eq. (ADINA 8.7.1)
Meshes	Unstructured mesh (Tetrahedral type) 875,000 meshes, $\Delta = 3.5 \times 10^{-2}D$
Boundary Conditions	Inflow B.C.: Turbulent flow (turbulence intensity = 2%) Wall B.C.: no-slip Outflow: Pressure out
Turbulence Model	Detached Eddy Simulation model - Spalart - Allmaras model ($\mu_t = \rho \nu_{eff}$)

KRIS

The effects of Reynolds number

- The deviation of each value from the average value of S-type Pitot tube coefficients was less than 0.3% within entire range of Reynolds numbers
- The effect of Reynolds number on S-type Pitot tube coefficients is negligible compared to the total uncertainty of measurements

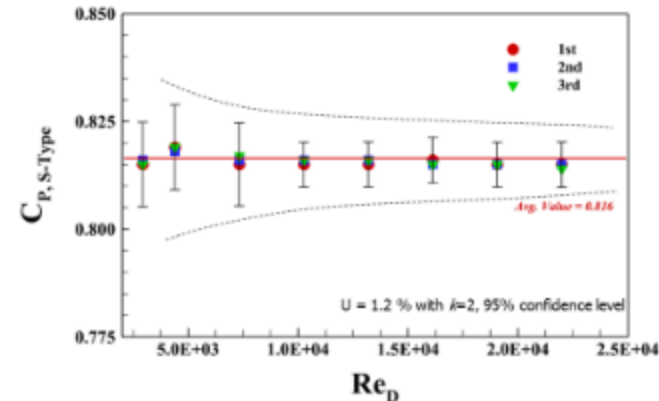

KRIS

The effects of Reynolds number

- Due to complicated geometry between the impact and wake orifices, the separated flows are developed to a vortical structure behind impact orifice
- The flow phenomena around S-type Pitot tube appear identically regardless of the change of Reynolds number

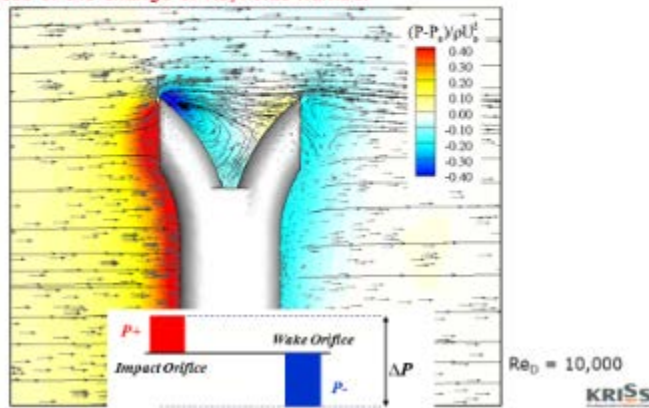

KRIS

The effects of Yaw angle misalignment

- S-type Pitot tube coefficients (C_p) at each yaw angle are normalized by S-type Pitot tube coefficients ($C_{p,0}$) at a yaw angle of 0°
- The normalized S-type Pitot tube coefficients decreased by up to -2% as the yaw angle increases to $\pm 10^\circ$ with symmetric tendency

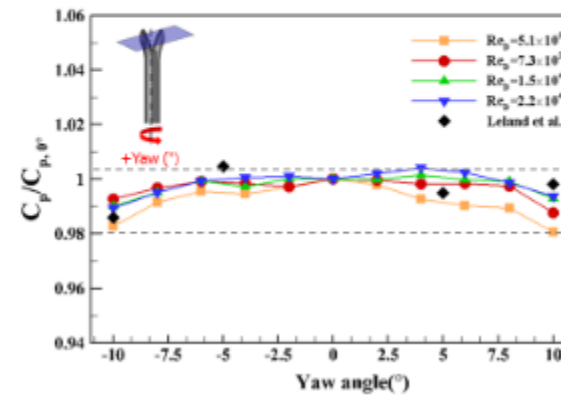

KRIS

The effects of Yaw angle misalignment

- Pressure values near wake orifice decrease due to the enhancement of separated flow from orifice surface, which shows symmetry \pm yaw angle

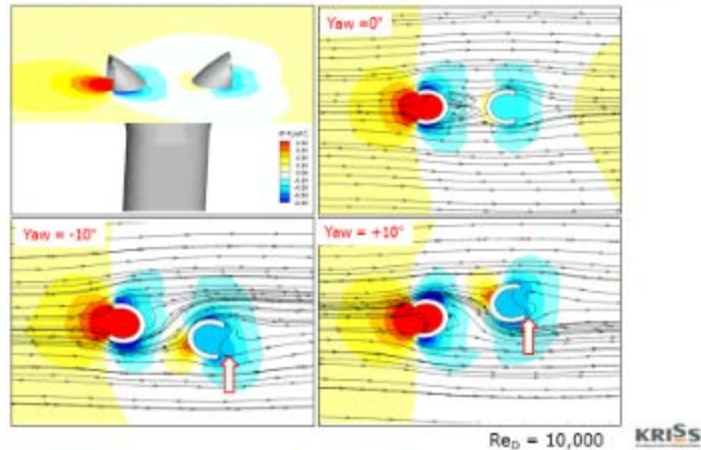

The effects of Pitch angle misalignment

- The normalized S-type Pitot tube coefficients increase up to 4% as the pitch angle increases to +10°
- In negative Pitch angles, S-type Pitot coefficients decrease to -2%, which can occur in industry stacks due to deflection of long S type Pitot tube

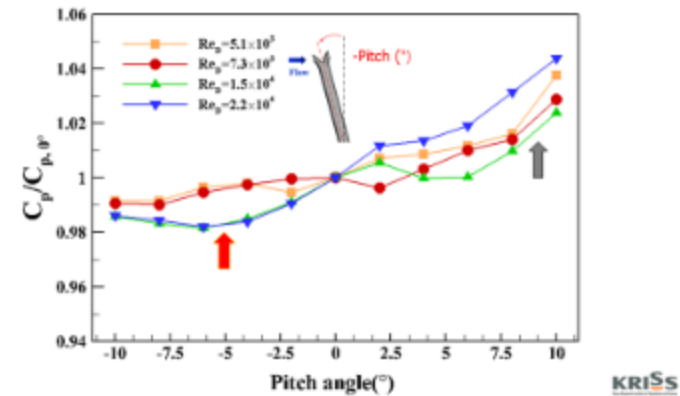

The effects of Pitch angle misalignment

- In the positive pitch angle, the incoming flow separate strongly at the upper edge of the impact orifice due to tilted geometry
- Recovery of the pressure distribution near wake orifice

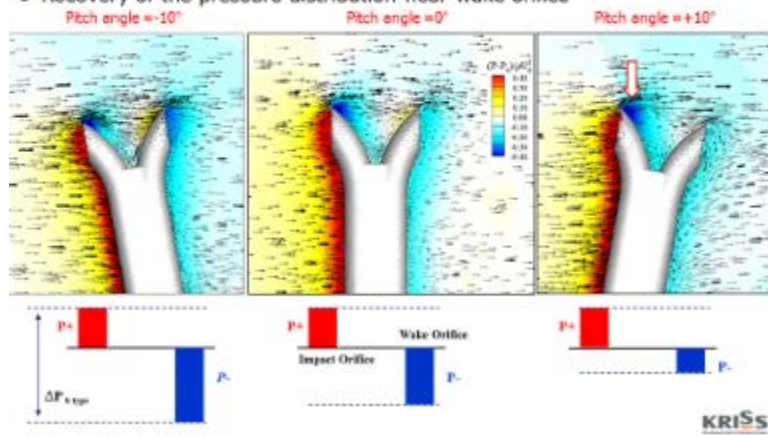

The effects of Pitch angle misalignment

- In the negative pitch angle, low pressure distributions are observed near wake orifice because a vortical structure grows behind the wake orifice
- S-type Pitot tube coefficients decrease for negative yaw angle by the definition of S-type Pitot tube coefficient

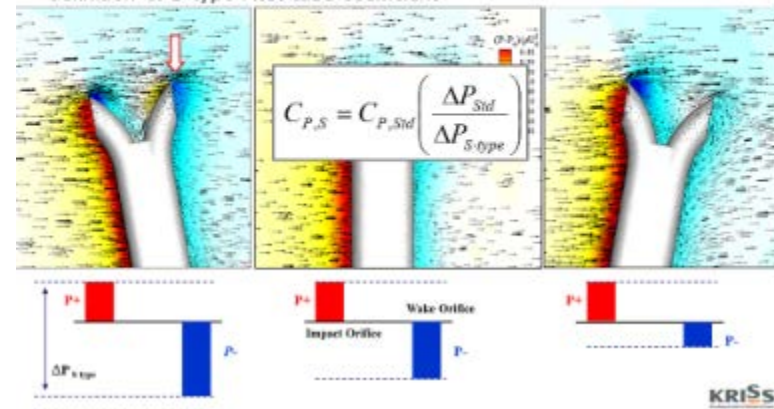

Manufacturing Quality

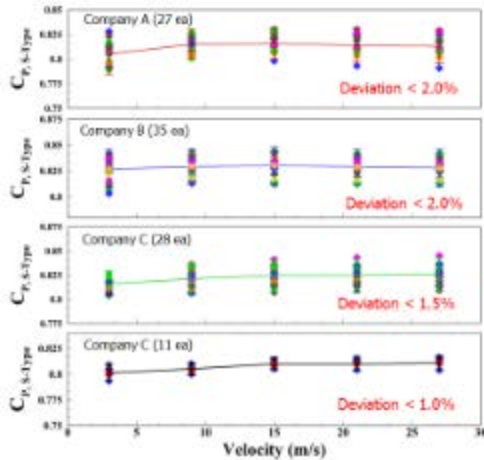

- 101 ea of S-type Pitot tubes of 4 major manufacturers in KOREA were calibrated in accredited calibration laboratory (Korea Environment Corporation) in 2011
- The deviations of the S-type Pitot tube coefficients for the same product of one company vary from 1% to 2%
- Difference in the level of manufacturing quality of company due to not-strong regulation for standard geometry of S-type Pitot tube

KRISs

Manufacturing Quality

- 4 S-type Pitot tubes manufactured as same model by one company
- S-type Pitot tube calibration for comparison of 4 S-type Pitot tube coefficients

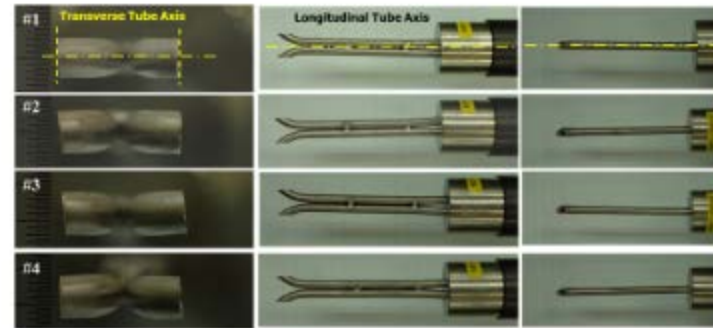

KRISs

Manufacturing Quality : Sample #1

- Transverse tube axis is perpendicular to the surface of two orifices, longitudinal tube axis is parallel to S-type pitot tube

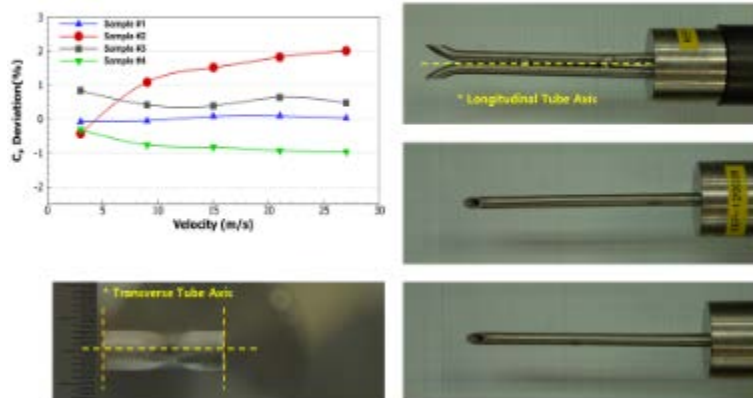

KRISs

Manufacturing Quality : Sample #2

- Deviation of S-type Pitot tube coefficient increases up to 2% as the velocity increase

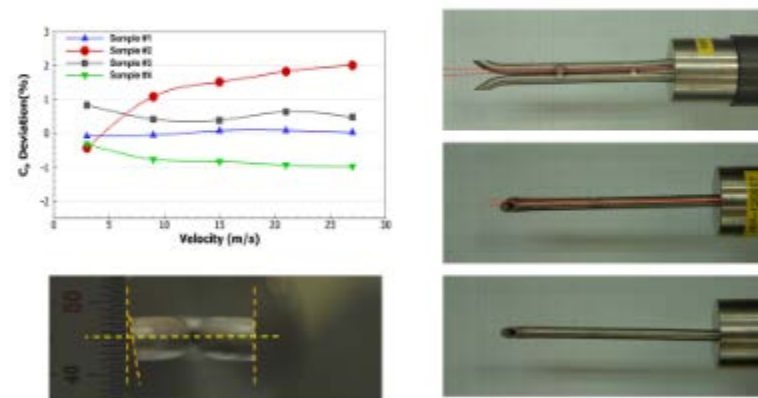

KRISs

Manufacturing Quality : Sample #2

- Tilted longitudinal tube axes can induce pitch and yaw angle misalignment
- Asymmetric twisted surfaces of the impact and wake orifices

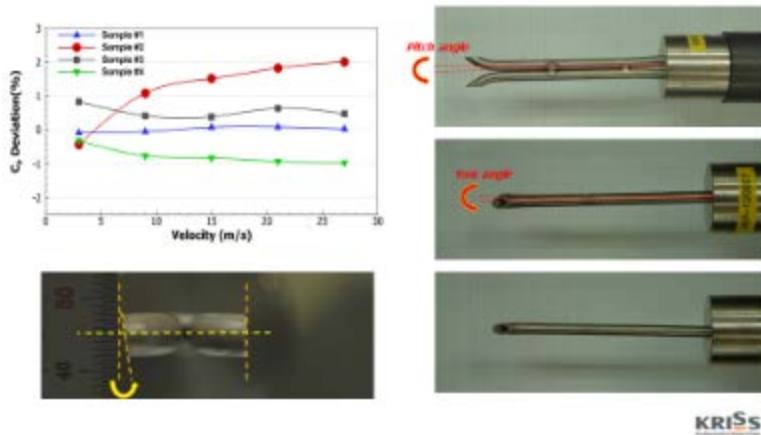

Manufacturing Quality : Sample #3

- Asymmetric twisted surfaces of the impact and wake orifices

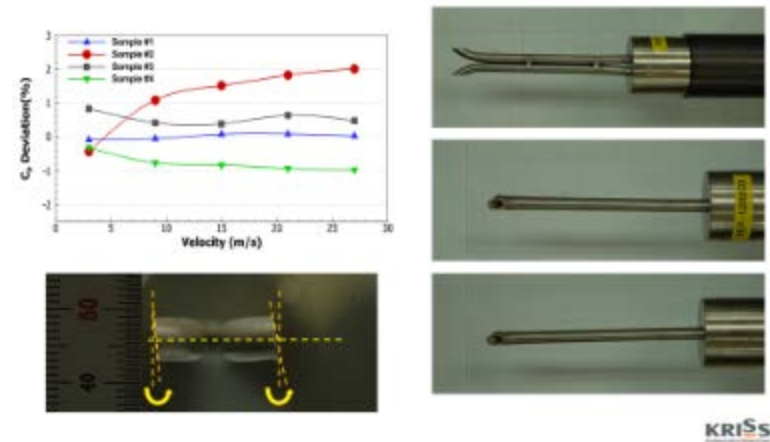

Manufacturing Quality : Sample #4

- Asymmetric twisted surfaces of the impact and wake orifices with tilted longitudinal tube axes

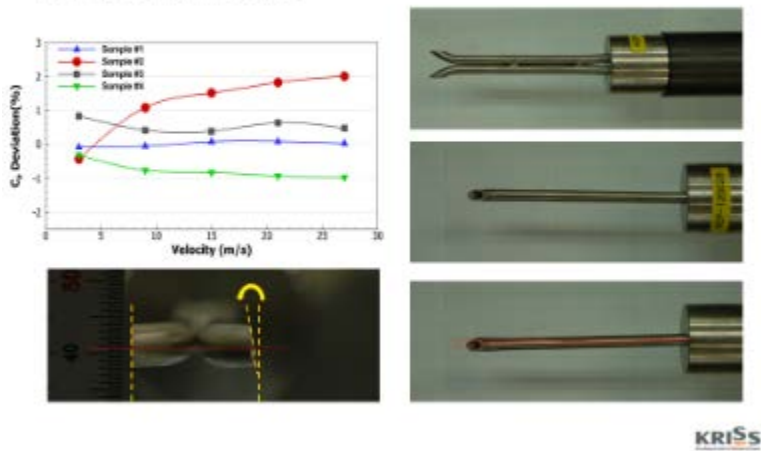

Future work : Numerical simulation

- Combined and complicated effect of deformed geometry of S-type Pitot tube

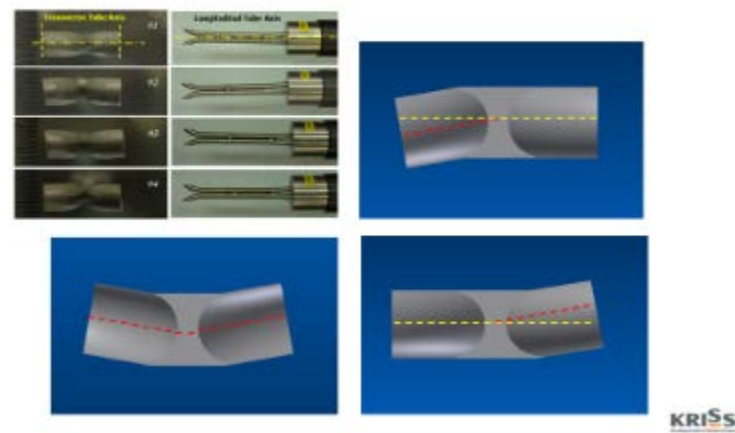

Uncertainty Evaluation

- 9th ISFFM, Kang et al. "Uncertainty Analysis of Stack Gas Flow Measurement with S-Type Pitot Tube for Estimating GHG Emissions"

$$Q = V \times A \times \frac{T_{std}}{T_s} \times \frac{P_s}{P_{std}} \times (1 - X_w) \times 300$$



Conclusion

- S-type Pitot tube is mainly applied to measurement stack velocity for CEM in KOREA
- The effect of Reynolds numbers, misaligned installations and manufacturing quality on S-type Pitot tube coefficients were investigated by wind tunnel experiments and numerical simulation
- As long as S-type Pitot was manufactured properly, the change of Reynolds number has no effect on S-type Pitot tube coefficients
- S-type Pitot tube coefficients decreased by up to -2% as yaw angle misalignments occurred between -10° and + 10°
- The maximum deviation of S-type Pitot tube coefficient is approximately -2% for negative pitch angle (deflection of Pitot tube), 4% for positive pitch angle
- The deviation of S-type Pitot tube coefficients for the same manufactured products varied from 1% to 2% due to insufficient manufacturing quality control. It can cause additional errors with misalignment effect

KRISs

Uncertainty Evaluation

- Largest uncertainty component is the velocity distribution inside the stack in uncertainty budget

Symbol	Value	unit	Uncertainty component		Sensitivity coefficient	Combined uncertainty contribution
			Type A %	Type B %		
C_p	0.826	-	-	0.55	1	0.55 %
ΔP	136.4	Pa	0.80	1.09	0.5	0.66 %
ρ	1.33	kg/m ³	0.0054	1.05	0.5	0.53 %
D	2600	mm	-	0.23	2	0.46 %
P_s	756	mmHg	0.0019	0.13	1	0.13 %
T_s	409	K	0.0046	0.24	1	0.25 %
$1-X_w$	91.5	%	0.0016	0.30	1	0.30 %
ΔV_D	14.8	m/s	1.54	-	1	1.54 %
Q	12972.6	m ³ /min (6min)				
Combined uncertainty of the flow rate measurement						1.94 %
95 % confidence level, $k=2$						2
Expanded Uncertainty, U						3.88 %

KRISs

7.3.9 Greenhouse Gas Emissions – A Case Study on the Calibration of an L-pitot Static Tube

Eric Harman (CEESI)

Session: Pitot Probe Characterization and Calibration

An alternate methodology for calibrating Pitot tubes, Anemometers, Hot-Wire Probes, and other Point-Velocity Devices is described utilizing NIST Traceable Mass Flow Measurement Standards, velocity profile conditioning, velocity profile mapping and normalization techniques. This methodology was used to determine three Pitot-static flow coefficients. The resulting average of the three experimentally determined flow coefficients was within 0.4% of a theoretically calculated flow coefficient. An uncertainty analysis of the experimentally determined flow coefficients produced an estimated uncertainty of 0.62% at one sigma.

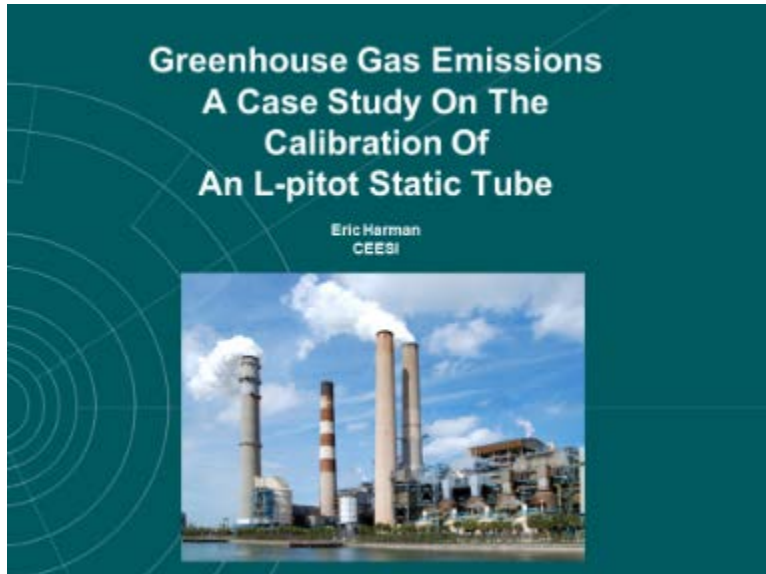

Stack Flow Measurement 

RATA Tests are often based on "S" Pitot Tubes

Advantages:

- Cheap
- Simple design
- Doesn't plug



Disadvantages:

- Questionable accuracy
- Problems with swirl

3-D Pitot Tubes

Advantages:

- Can measure swirl vectors (yaw)
- Can measure radial vectors (pitch)

Problems:

- Requires calibration

EPA adds wind tunnel calibration requirements which are often based on L-pitot static tubes

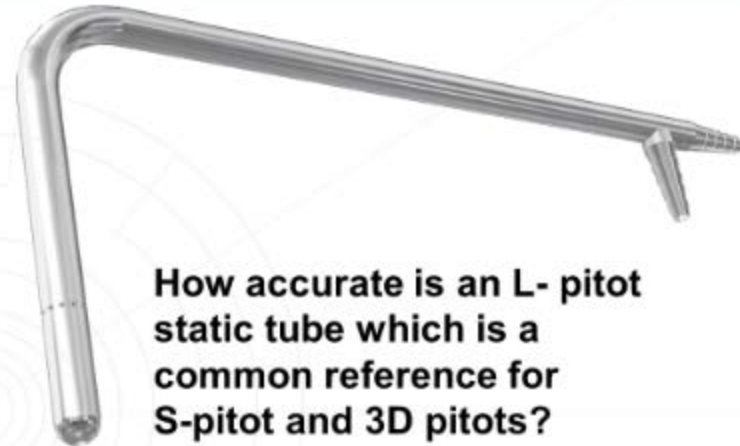
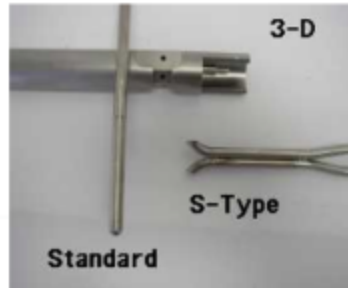

How accurate is an L- pitot static tube which is a common reference for S-pitot and 3D pitots?

Alternate Calibration Methodology For Point-Velocity Devices (Pitot-Tubes, Anemometers, Hot-Wire Devices) Using NIST Traceable Mass Flow Measurement Standards

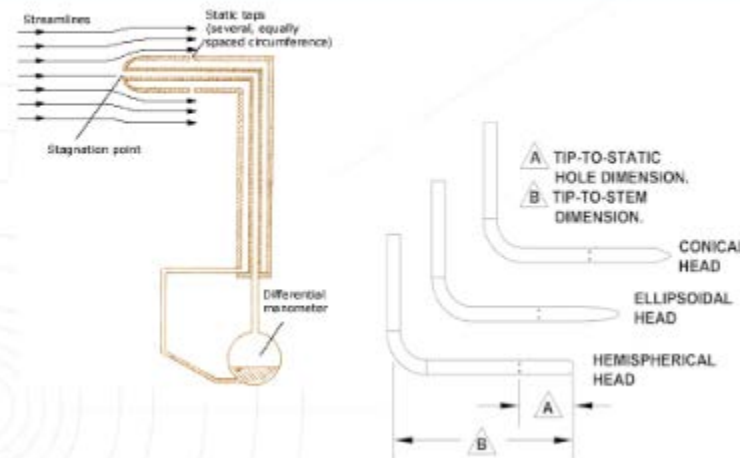

Pitot-Static Tube Physics

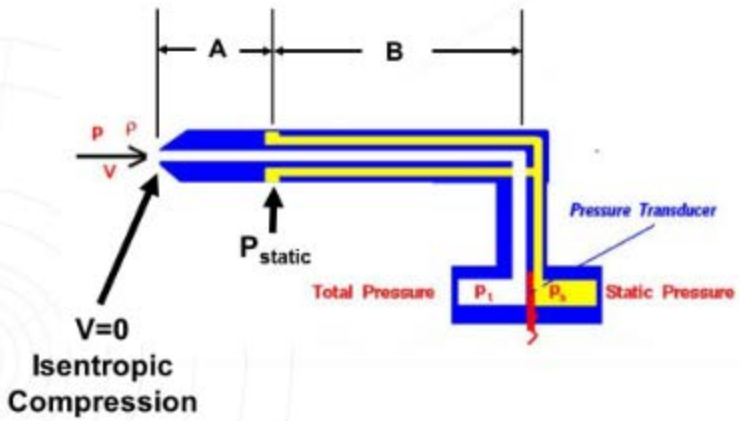

Not All Static Pitot Tubes are the same

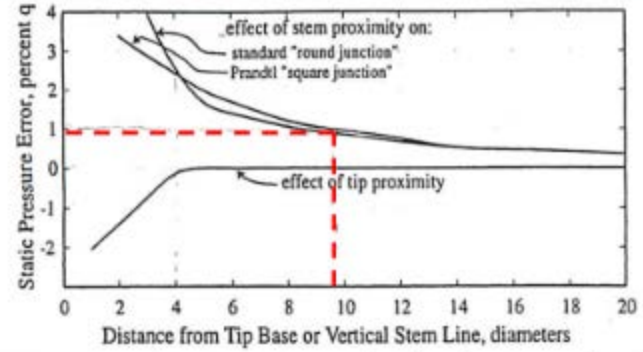

FIGURE 4.9 Effect of static orifice distance from tip or from stem: see Example 4.1.

Point-Velocity Calibration



$$V = K_{factor} (\text{output})$$

From Lab \nearrow \uparrow Measured

Traditional Method

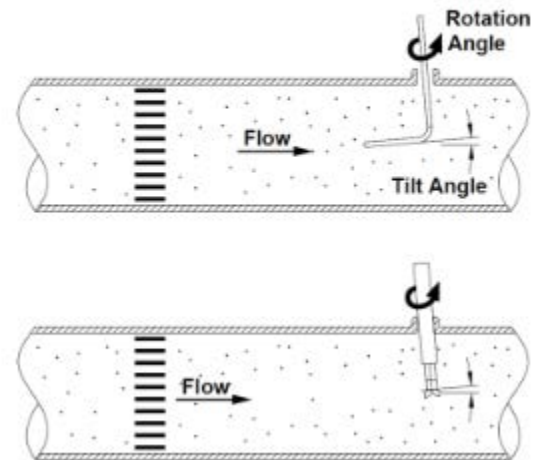

Traditional Calibration Methodology Pitfalls

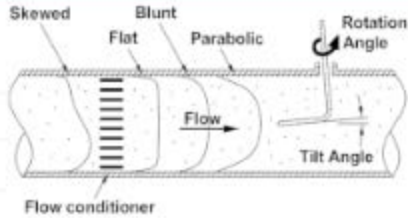

- STEP 1.
- Set flow and record velocity with Pitot-Static Tube that has a known Pressure Coefficient (C_p).
 - Avoid Tilt & Rotation Errors.

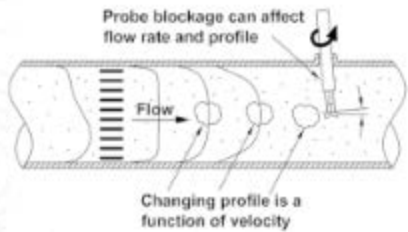

- STEP 2.
- Maintain identical flow rate.
 - Remove the Pitot-Static Tube.
 - Position the Point Velocity Device in the exact same location.
 - Make sure the blockage of Point Velocity Device does not alter the fluid velocity by reducing the flow area or increasing the pressure drop causing a lower fan output.
 - Make sure velocity range does not cause an adverse localized velocity gradient.
 - Avoid Tilt & Rotation Errors.

One Slight Problem



Reference Standard is maybe only as good as the MUT

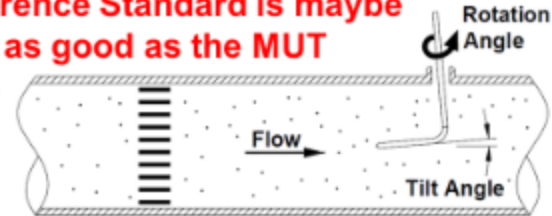

Solution: Call NIST

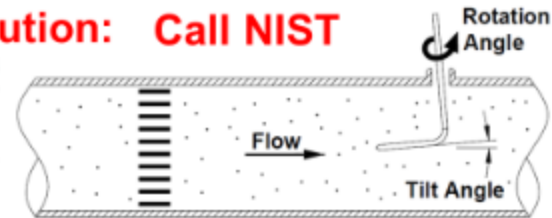

Alternate Point-Velocity Calibration Methodology

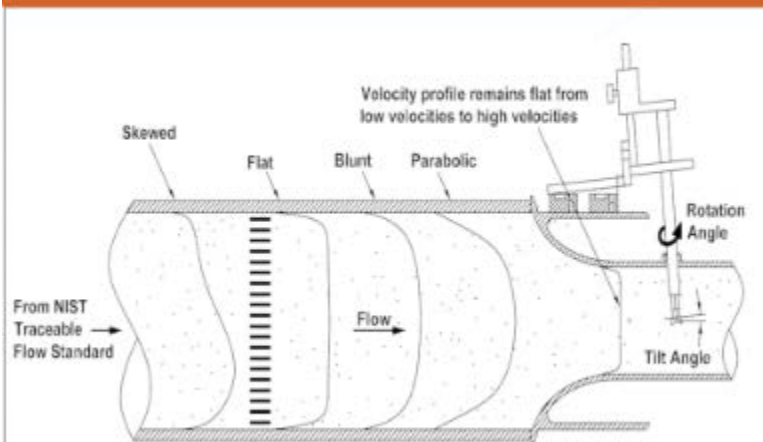

Test Configuration

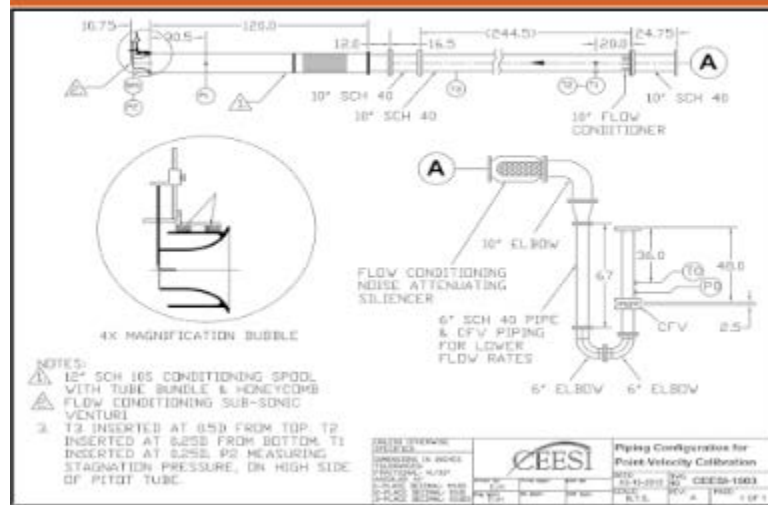

The Hardware



Step-by-step Alternate Methodology



1. Determine the mass flowrate (\dot{m}) from an upstream NIST traceable flow standard.
2. Determine the gas density (ρ) at the calibration location from temperature and pressure measurements.
3. Divide the mass flowrate by the gas density and the throat area (A_{throat}) of the sub-sonic venturi to determine the bulk (average) velocity in the calibration location.

$$V_{Average} = \frac{\dot{m}}{\rho \cdot A_{throat}}$$

4. Correct the average velocity by the projected area of the Pitot-static tube. Note, this does not include the Pitot-static's stem area.

$$V_{Ave-corrected} = V_{Average} \cdot \frac{A_{throat}}{(A_{throat} - A_{pitot})}$$

The Hardware

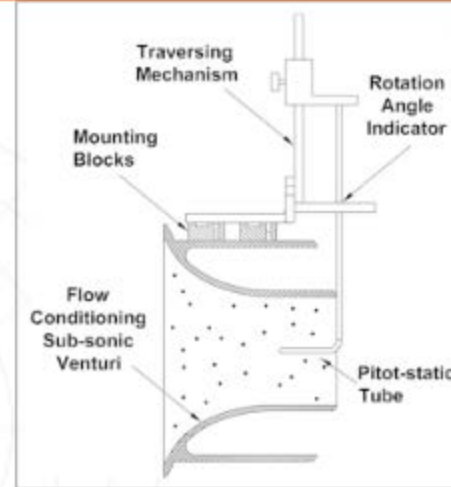

Step-by-step Alternate Methodology



5. Using an uncalibrated Pitot-static tube, perform a pitot traverse at the calibrating velocity ranges, while monitoring the flow standard. Apply the equation below to determine individual velocities at each traverse location. If slight variations occur in the flowrate during the pitot traverse, the velocities can be normalized by multiplying by the average mass flow rate during the testing, and by dividing the mass flowrate during the individual traverse point as shown below.

$$V_i = N \cdot K_{initial} \sqrt{\frac{h_{w-i}}{\rho_i}} \left(\frac{\dot{m}_{average}}{\dot{m}_i} \right)$$

6. **Determine a Profile Factor (PF)** that relates the average velocity in the throat of the sub-sonic venturi to the velocity in the center. Notice how the initial Pitot-static flow coefficient ($K_{initial}$) drops out of the equation.

$$PF = \frac{N \cdot K_{initial} \sqrt{\frac{h_{w-center}}{\rho_{center}} \left(\frac{\dot{m}_{average}}{\dot{m}_{center}} \right)}}{N \cdot K_{initial} \frac{\sum \left[\sqrt{\frac{h_{w-i}}{\rho_i} \left(\frac{\dot{m}_{average}}{\dot{m}_i} \right)} \right]}{n}} = \frac{\sqrt{\frac{h_{w-center}}{\rho_{center}} \left(\frac{\dot{m}_{average}}{\dot{m}_{center}} \right)}}{\frac{\sum \left[\sqrt{\frac{h_{w-i}}{\rho_i} \left(\frac{\dot{m}_{average}}{\dot{m}_i} \right)} \right]}{n}}$$

- Three Pitot-static tubes were tested using the Alternative Methodology.
- The Pitot-static tubes were positioned in the center of the nozzle, and tested from 10 to 115 m/sec.
- The percent deviation between the experimentally determined flow coefficients (K) and theory was determined where:

$$K_{theory} = \left\{ \left(\frac{\gamma}{\gamma - 1} \right) \left(\frac{P_1}{P_t - P_1} \right) \left[\left(\frac{P_t}{P_1} \right)^{\frac{\gamma - 1}{\gamma}} - 1 \right] \right\}^{\frac{1}{2}}$$

7. Profile Factors (PF) can be calculated for different velocities, and curve fit to different Throat Reynolds Numbers.

$$PF = f(Re_{throat})$$

8. The Point Velocity Device can be inserted into the center of the sub-sonic venturi, and its flow coefficient can be determined by the following equation.

$$K = \frac{PF}{N \cdot (A_{throat} - A_{pitot})} \cdot \frac{\dot{m}}{\sqrt{\rho \cdot h_w}}$$

Summary of the Percent Deviation between Experimentally determined Flow Coefficients and Theoretical Flow Coefficients

Pitot-static Tube No.	Perent Average Deviation*	Percent Standard Deviation*
#60	-0.5	0.84
#61	-0.2	0.58
#62	-0.5	0.62
Averages:	-0.4	0.7

* Over the entire velocity range tested

K-factor vs. Pitot Tube Reynolds Number

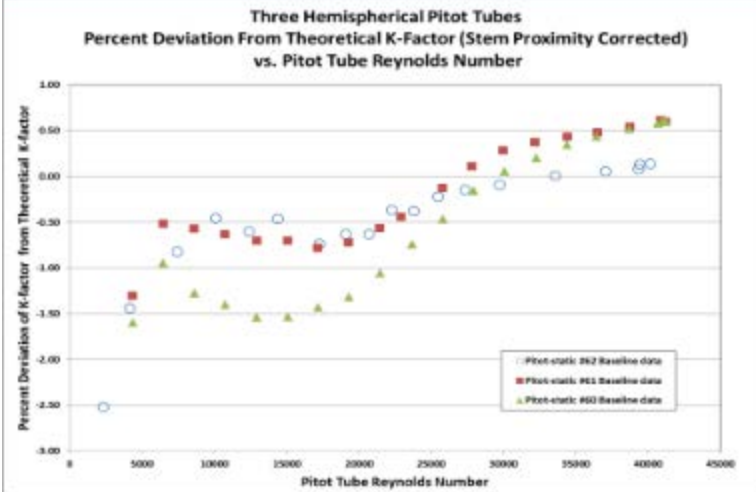

K-Factor vs. Velocity

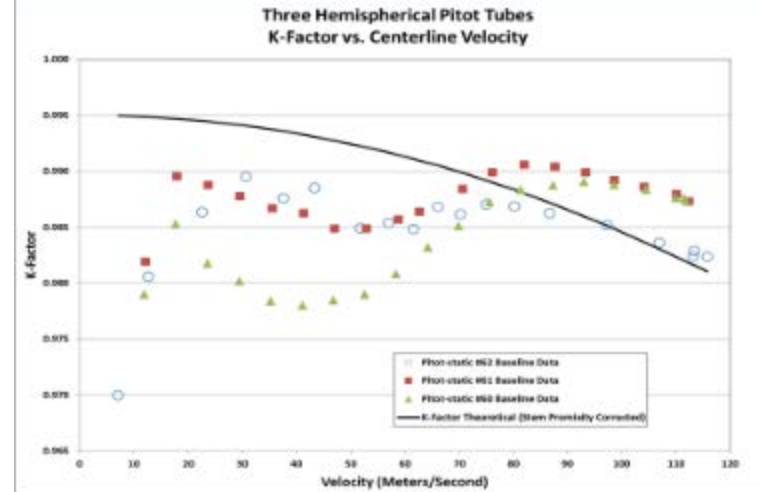

Uncertainty



The following equation was used to determine the Pitot-static Tube's flow coefficient (K) uncertainty.

$$\frac{U_e(K)}{K} = \sqrt{\left[\left(\frac{\partial K}{\partial \dot{m}}\right) \frac{U(\dot{m})}{\dot{m}}\right]^2 + \left[\left(\frac{\partial K}{\partial V_{pf}}\right) \frac{U(V_{pf})}{V_{pf}}\right]^2 + \left[\left(\frac{\partial K}{\partial P_1}\right) \frac{U(P_1)}{P_1}\right]^2 + \left[\left(\frac{\partial K}{\partial T_1}\right) \frac{U(T_1)}{T_1}\right]^2 + \left[\left(\frac{\partial K}{\partial h_w}\right) \frac{U(h_w)}{h_w}\right]^2}$$

Where:

\dot{m} = mass flow rate from the Critical Flow Venturi, pounds-mass/sec

V_{pf} = Velocity profile factor in the sub-sonic venturi

P_1 = Static pressure in the sub-sonic venturi, psia

T_1 = Absolute sub-sonic venturi temperature, °R

h_w = Differential pressure produced by the Pitot-static tube,

"H₂O

Uncertainty



Applying the appropriate sensitivity coefficients the equation above yields.

$$\frac{U_e(K)}{K} = \sqrt{\left[\frac{U(\dot{m})}{\dot{m}}\right]^2 + \left[\frac{U(V_{pf})}{V_{pf}}\right]^2 + \left[\frac{1}{2} \frac{U(P_1)}{P_1}\right]^2 + \left[\frac{1}{2} \frac{U(T_1)}{T_1}\right]^2 + \left[\frac{1}{2} \frac{U(h_w)}{h_w}\right]^2}$$

Applying the test uncertainties the equation above yields.

$$\frac{U_e(K)}{K} = \sqrt{[0.35]^2 + [0.1]^2 + \left[\frac{1}{2} \cdot 0.1\right]^2 + \left[\frac{1}{2} \cdot 0.1\right]^2 + \left[\frac{1}{2} \cdot 1.0\right]^2} = 0.62\%$$

The expanded uncertainty of the Pitot-static flow coefficient (K) at two-sigma is 1.24%

- Individual averages of all three experimentally determined flow coefficients were within the estimated uncertainty of 0.62% at one sigma of the theoretically calculated flow coefficient.
- Flow coefficient deviations were likely a result of imperfections in the Pitot-static tube's surfaces and geometry, and the turbulence levels during testing.
- Better uncertainty could be achieved using more accurate DP transducers which contributed greatly to the uncertainty budget.
- $\pm 0.5\%$ DP transducers would have produced a 0.9 % uncertainty at two sigma.

7.3.10 NIST's New 3D Airspeed Calibration Rig Addresses Turbulent Flow Measurement Challenges

Iosif Shinder (NIST)

Session: Pitot Probe Characterization and Calibration

The presentation summarizes the NIST 3-D airspeed calibration rig and sensor calibrations in turbulent flow. Specific topics of discussion are: how to simulate high intensity turbulence in a wind tunnel; how to measure it; the effect of turbulence on 2-D and 3-D airspeed differential sensors; and challenges and future research in 2-D and 3-D airspeed measurements.

NIST's New 3D Airspeed Calibration Rig Addresses Turbulent Flow Measurement Challenges



Authors: Iosif Shinder, Vladimir Khromchenko, Michael Moldover

What is this talk about?

- Why we are doing 2-D and 3-D calibrations?
- 3-D Calibration Rig.
- How turbulence intensity affects calibration.
- Traditional turbulence generators.
- Flag-like turbulence generator.
- How to measure turbulence?
- Low turbulence s-probe calibration.
- Pitot tube and s-probe in turbulent flows.

Flow is Complicated



Real stacks have swirls and turbulence

Flow is Complicated

Real stacks have skew

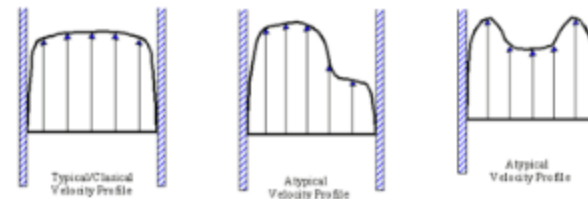

How are Emissions Measurements Made Today?

Emission is a product of **concentration** and **flow**

Flow Problems:

No Traceability to NIST

There is so called: Annual "Relative Accuracy Test Audit" (RATA) which "calibrates" continuous emission flow monitors (usually ultrasonic flowmeter). Typically, the flow is surveyed with S-probe and 5-hole pitot static probes, which are temporarily installed on the stack.

For S-probes the calibration factor is fixed and these probes can be used without calibration for certain specified geometries.

As the name suggests, the EPA protocols provide only relative accuracy, not uncertainty relative to primary standards.

Wind Tunnel Parameters

- Test volume: 2 m long × 1.5 m wide × 1.2 m high
- Airspeeds up to 75 m/s (165 mi/hour)
- Uncertainties – 0.42% increasing to 1% near 1 m/s
- Low (0.1 %) turbulence intensity; to increase turbulence, we install turbulence generators upstream of the test volume

$$Tu = \frac{\sigma_{\vec{v}}}{\bar{V}}$$

Automated 3D Pitot Tube Calibration Rig (2013)

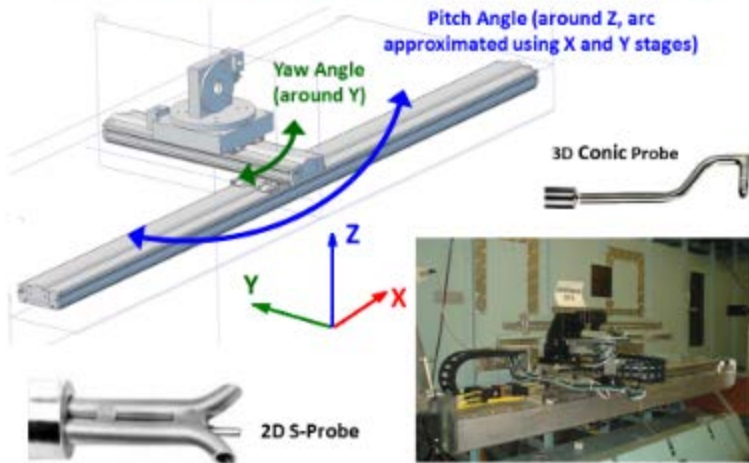

S-probe: workhorse for stack flow measurements



S-probe: cannot detect pitch

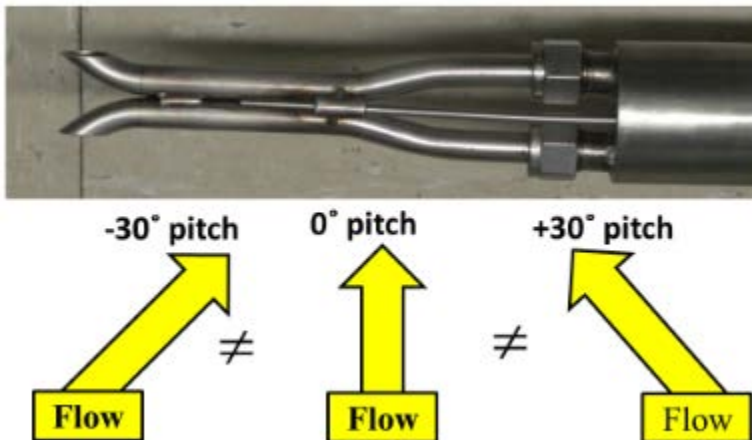

S-Probe, (used in EPA protocol 2)



Calibration Factor is a Function of 4 variables

1. Air speed
2. Pitch angle
3. Yaw angle
4. Turbulence intensity

EPA protocol assumes calibration factor = 0.84
(literature shows small, linear dependence on air speed)

EPA Method 2: S-Probe Calibration

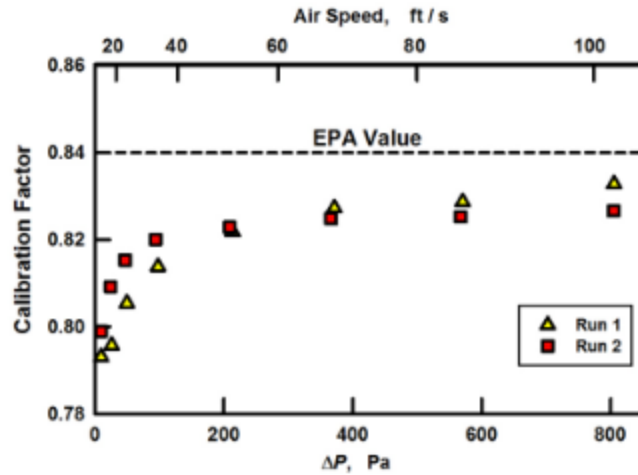

Calibration data for one probe; others might be different.

360° S-Probe response in 2° steps 10 m/s; 0° pitch

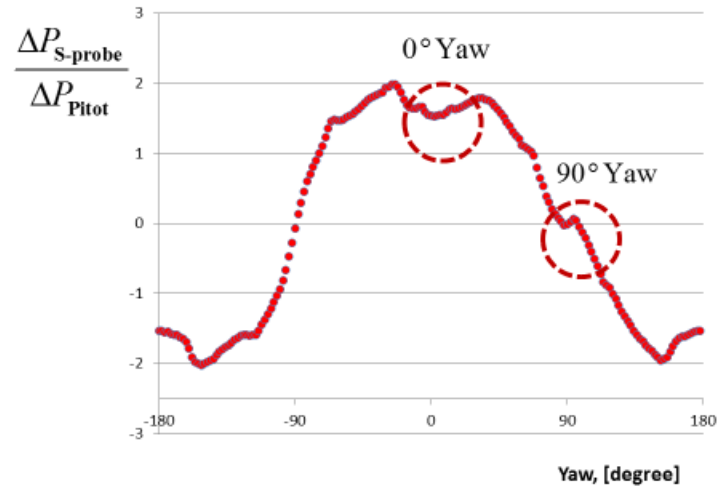

NIST Calibration of S-Probe

Flow: 10 m/s, turbulence intensity < 0.5%

Magnify 0° and 90°

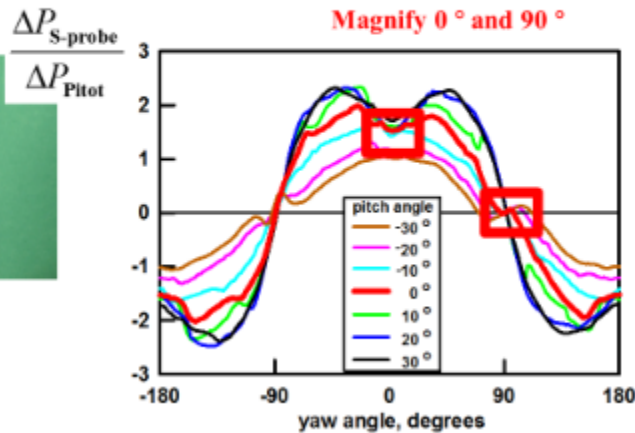

S-Probe (used for CEM per EPA protocol 2)

flow: 10 m/s, turbulence intensity < 0.5%

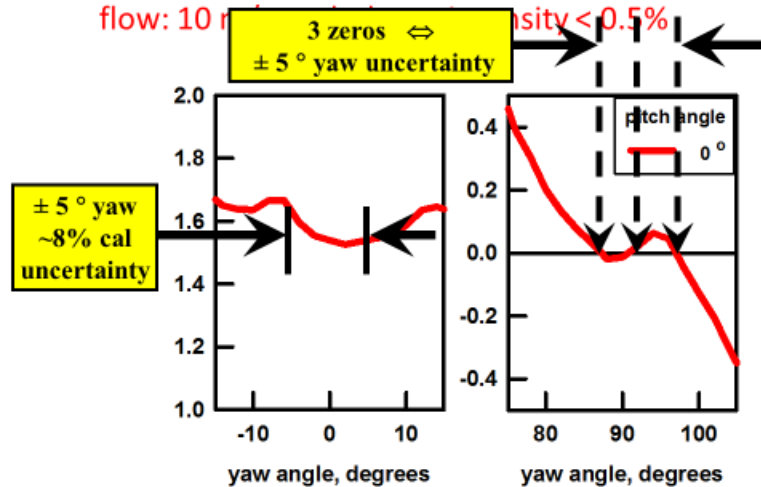

S-Probe (used for CEM per EPA protocol 2)
 Flow: 10 m/s, turbulence intensity < 0.5%

Calibration depends upon pitch angle

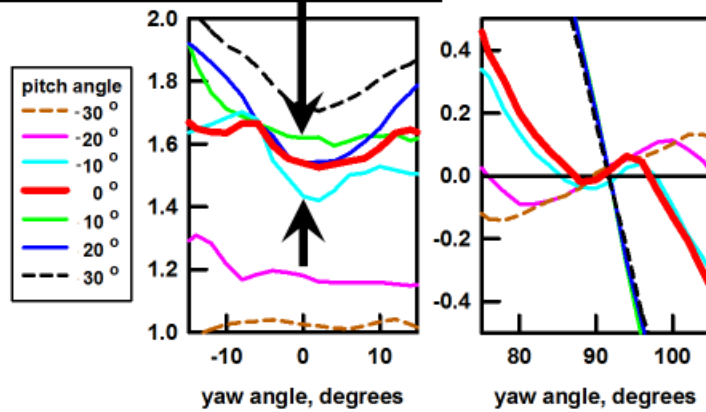

Effects of Pitch: Other Researchers

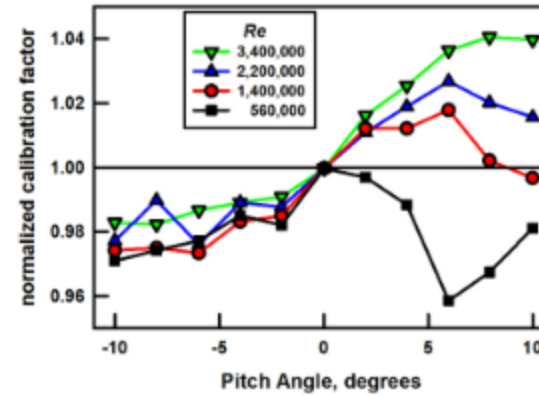

Adapted from:
 "Experimental Study of the Factors Effect on the S type Pitot Tube Coefficient"
 Nguyen Doan Trung et. al. XX IMEKO World Congress

Calibration factor has hysteresis in low turbulence
 Increasing turbulence reduces hysteresis

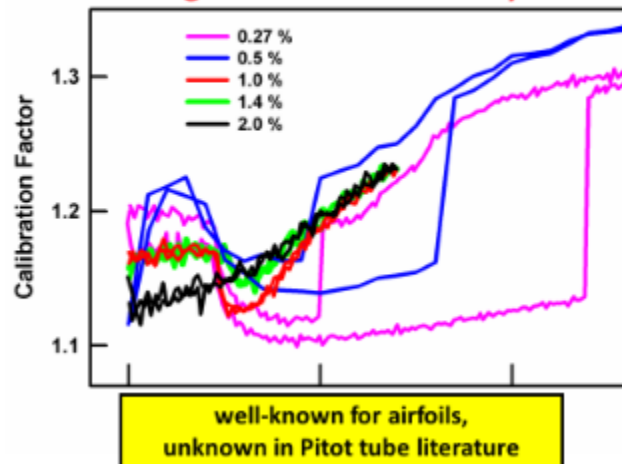

Calibration of Multi-Hole Pitot Tubes

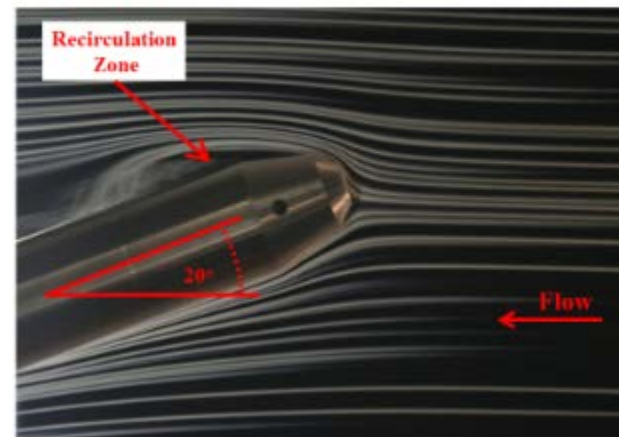

Modify wind tunnel: add Grid to Generate Turbulence



Measure Effects of Grid. Periodic Structure.

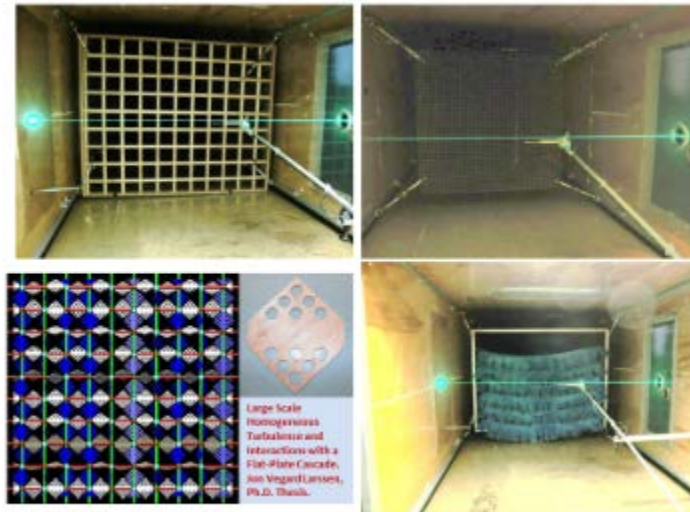
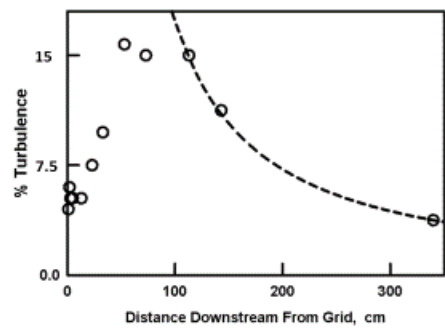
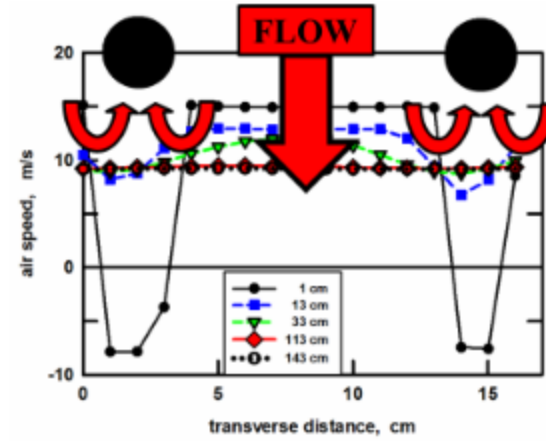

Turbulence intensity probes

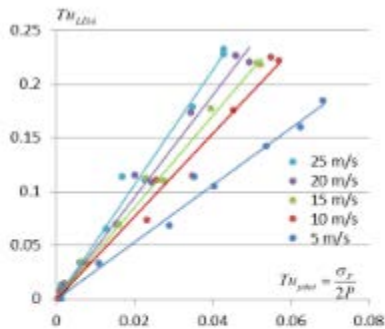
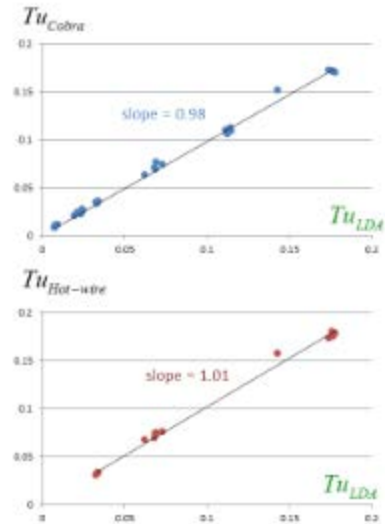
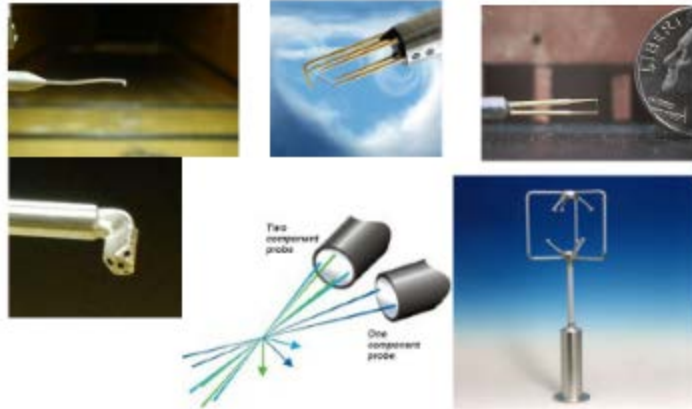

L-shape pitot tube turbulence calibration

$$\frac{Tu_{LDA}}{Tu_{Pitot}} = F_1(V) F_2(Tu)$$

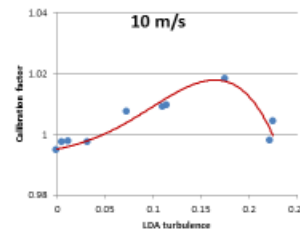
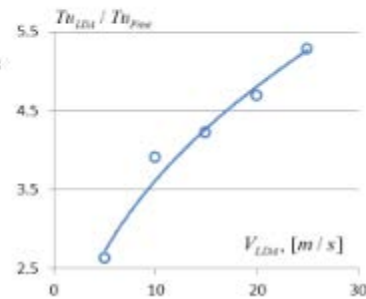

$$V_p / V_{NIST} = F_1(Re) F_2(Tu)$$

$$\left(\frac{\Delta P}{\rho V^2} \right) = 1 + a(Tu)^2$$

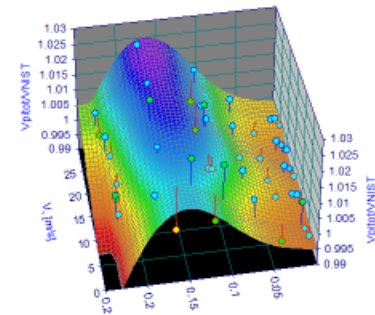

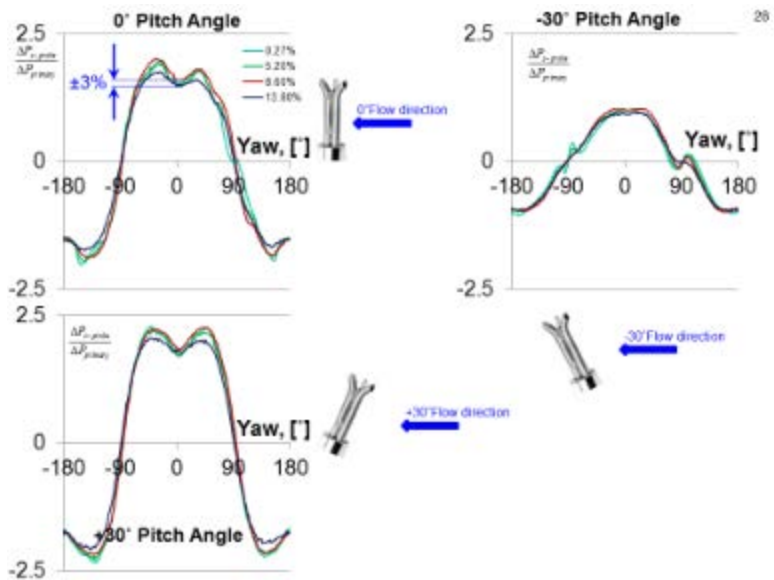

Summary

1. NIST calibrates S-probes and 3D (multi-hole) probes.
2. S-probes can have multiple nulls. Incorrect nulling may cause errors during calibrations and measurements.
3. S-probes are sensitive to pitch angle; therefore, calibration factors does not represent measured flow.
4. Five-hole pitot tubes are sensitive to turbulence intensity.
5. Regular pitot tube and s-probe much less sensitive to turbulence.
6. NIST has studied only a few probes. How sensitive are other probes to turbulence?

7.3.11 Scale-Model Smokestack Simulator (SMSS) – A Facility to Study the Uncertainty of CEMS and RATA Flow Measurements

Aaron Johnson (NIST)

Session: NIST Facilities and Flow Measurement Research

The amount of CO₂ emitted from a coal-fired power plant (CFPP) is measured by continuous emissions monitoring systems (CEMS) permanently installed in the exhaust smokestack. Both the CO₂ concentration and the bulk flow are continuously measured by CEMS, and the product of these measurements gives the CO₂ flux. The EPA requires CEMS to be calibrated yearly using a test procedure called a relative accuracy test audit (RATA). This calibration procedure links the concentration measurement to the SI through reference gas standards. However, establishing flow traceability is more difficult because the CEMS flow meter and the flow meter used to perform the RATA can be adversely affected by the complex velocity fields (i.e., swirling flow with a skewed velocity profile) prevalent in smokestacks. As a result the RATA only provides “relative accuracy” instead of flow traceability to a primary standard. In order to quantify the uncertainty of smokestack flow measurements, and to establish a calibration platform with documented traceability to the derived SI unit of flow, NIST constructed a 1/10th scale model smokestack simulator (SMSS). The test section of the SMSS will have the same velocity range and similar flow distortions found in to a typical CFPP smokestack. However, the SMSS will provide reference flow measurements at expanded uncertainties of less than 1 %. This presentation discusses the design and capabilities of the SMSS and presents Computational Fluid Dynamics (CFD) results of the expected velocity field in the SMSS facility.

Scale-Model Smokestack Simulator (SMSS)

A Facility to Study CEMS and RATA Flow Measurements



Measurement Challenges and Metrology for Monitoring
CO₂ Emissions from Smokestacks Workshop

April 21, 2015
Gaithersburg, MD

Aaron N. Johnson
Fluid Metrology Group, NIST

Why are Emissions Measurements Difficult?

- **High Reynolds number** ~ 10⁷; too large to be reproduced in lab.
- **Flow is fast:** 6 m/s to 26 m/s
- **Nasty conditions:**
 - Access via outside cat-walk 90 m (300 ft) above ground on older stacks
 - Noisy
 - Gas is either “hot” (no scrubber 90+ °C) or “ambient & raining” (scrubber)
 - Gas is asphyxiating: composition (by volume)
 - 13.7% CO₂
 - 3.4% O₂
 - 74.8% N₂
 - 8.0% H₂O
- **Stacks are big:** no lab can calibrate a 10 m diameter flow meter
- **Flow is complicated**

How are Emissions Measurements Made Today?

- Using EPA-approved protocols
 - the bulk gas flow is continuously monitored, and
 - the composition is continuously analyzed for O₂, CO, Hg, SO₂, NO_x to comply with emission controls
- The instruments used for 1) comprise the **CEMS = Continuous Emissions Monitoring System**
 - Typical CEMS use **ultrasonic meters (USM)** with one or two paths to monitor flow
 - CEMS require calibration
- Annual “*Relative Accuracy Test Audit*” (RATA) “calibrates” ultrasonic CEMS flow monitors.
 - the flow is surveyed with a **S-Probe**, that is temporarily installed on the stack.
 - As the name suggests, the RATA provides only **relative accuracy**, **not** necessarily uncertainty relative to primary standards.

Ultrasonic Meter (USM) Principle of Operation

- USM transducer emits **sound beam** of known frequency
- USM **measures the transit time** of the sound beam to travel a known distance (L) **with** and **against** the flow

$$t_{\text{with}} = \frac{L}{a + V_L} \quad t_{\text{against}} = \frac{L}{a - V_L}$$

- Averaged **path velocity** along path L

$$V_L = \frac{L}{2} \left(\frac{1}{t_{\text{with}}} - \frac{1}{t_{\text{against}}} \right)$$

- The USM determines the **flow velocity** by projecting the path velocity (V_L) onto the flow axis

$$V_{\text{USM}} = \frac{V_L}{\cos \theta} = \frac{L}{2 \cos \theta} \left(\frac{1}{t_{\text{with}}} - \frac{1}{t_{\text{against}}} \right)$$

Measurement Problems

- Profile Errors** – USM measures *path velocity*, and not the area weighted velocity
 - Swirl Errors** – measured path velocity (V_L) includes contributions **both** from the **axial** and **non-axial** (i.e., swirl) velocity components
 - Installation Errors** – depending on installation angle the acoustic path interrogates a different portion of flow field
- USM Calibrated by RATA

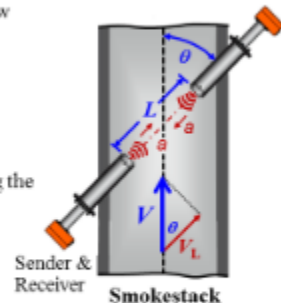

Measurement Need

Improve CO₂ measurements from coal-fired power plants

- to **assess** progress of carbon **mitigation efforts** and
- to **fairly implement future carbon controls** (e.g., carbon tax, cap and trade)
- to **provide accurate input data** for climate CO₂ mass balance models

NIST Objective: *SI-traceable, CO₂ flux measurements with 1 % expanded uncertainty at a reasonable cost to provide the technical basis for carbon control in the US and internationally*

S-Probe Calibration

Calibration Factor is a Function of 4 variables

- Reynolds Number (Air speed)
- Pitch angle (S-probe does not measure pitch)
- Yaw angle
- Turbulence intensity

EPA protocol assumes calibration factor = 0.84

- The calibration factor **exhibits Reynolds number dependence** (i.e., 4 % change with Reynolds number)
- Using the EPA calibration factor = 0.84 introduces **errors as large as 10%** depending for large pitch angles (pitch > 30° or pitch < -30°)

What is NIST Doing?

- 1) Tie EPA-CEMS instruments and protocols to primary standards (*Essential for International Recognition*)
 - A. Calibrate Pitot probes under realistic conditions ([NIST Wind Tunnel](#))
 - B. Determine accuracy of ultrasonic flow meters (USM) and S-Probes in complex *smokestack-like* flows ([Newly Built Scale-Model Smokestack Simulator](#))
 - C. Understand/model results to generalize and scale up ([CFD](#))
- 2) Invent alternative flow standards for flue gas stacks (*to check entire measurement chain*)
 - A. Advanced Multipath Ultrasonic Flow Meters
 - B. Long Wavelength Acoustic Flow Meter ([LWAF](#))
 - C. Tracer Dilution
- 3) Test accuracy of 1) and 2) in a near-scale industrial smokestack ([Newly Built National Fire Research Laboratory](#))

NIST's Scale-Model Smokestack Simulator (SMSS)



- Horizontal orientation for cost and safety
- SMSS is 1/10th the diameter of an industrial smokestack
- Air used as a surrogate for flue exhaust

Scale-Model Smokestack Simulator (SMSS)

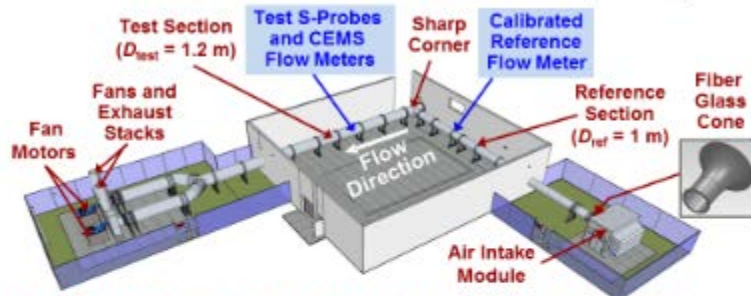

- Ambient air is drawn into the Intake Module by the 2 fans at the exit
- **Reference Section:**
 - Designed to produce an ideal velocity profile with no swirl
 - SI Traceable flow measurement via NIST calibrated flow meter
- **Test Section:**
 - Flow velocities range from 6 m/s to 26 m/s (*same as industrial smokestacks*)
 - Sharp corner generates turbulent, skewed, swirling flows
 - CEMS and S-Probes evaluated in smokestack-like flow conditions

Computational Domain for Modeling SMSS

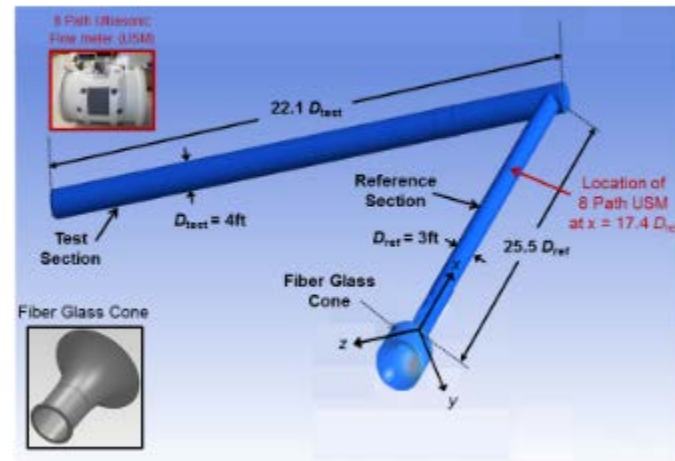

SMSS CFD Model

- Used Commercial Code ANSYS FLUENT
- 3D Steady, incompressible Reynolds Averaged Navier-Stokes Equations
- Turbulence Model
 - Realizable k- ϵ turbulence model with enhanced wall functions
- Fluid Properties
 - Air at constant temperature
 - Density; $\rho=1.225 \text{ kg/m}^3$,
 - Molecular Viscosity; $\mu=1.7894 \times 10^{-5} \text{ kg/m} \cdot \text{s}$
- Boundary Conditions
 - No slip at walls
 - Inlet Pressure at Spherical Volume: $P = 101,325 \text{ Pa}$ (absolute)
 - Outlet Pressure: $P = -2000 \text{ Pa}$ (gauge)
- Numerical Scheme
 - Solved using double precision,
 - **1st order spatial discretization**
 - Converged residuals on order of 10^{-3} or less
- Mesh
 - Unstructured with 9,800,000 cells

CFD Model

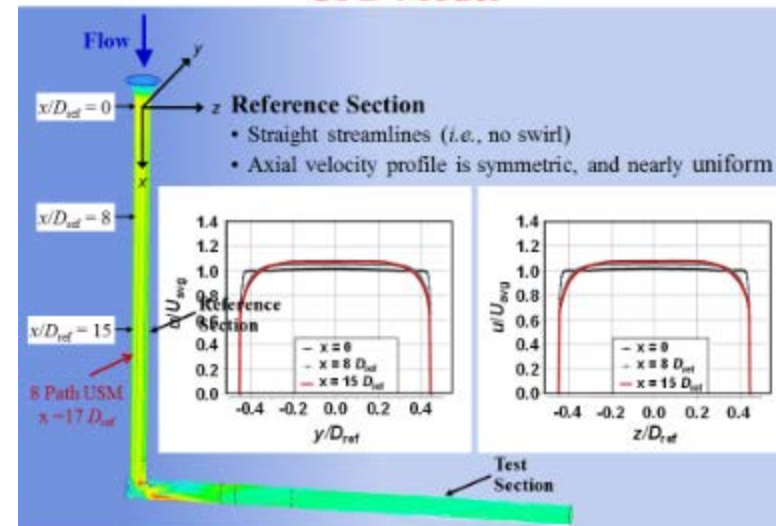

CFD Model

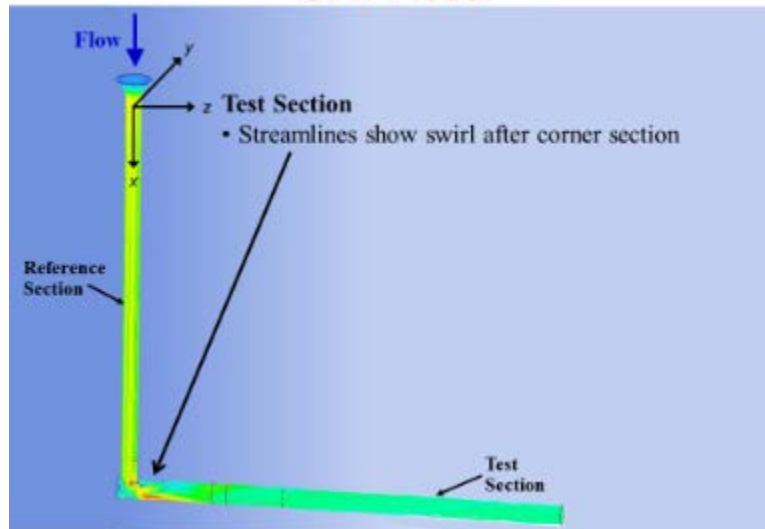

CFD Model

(Flow just after corner in Test Section)

Test Section

- Streamlines show swirl after corner section
- Faster moving flow toward outer wall in Region A
- Reverse flow near inner wall in Region B
- Recirculation Zone in Region C

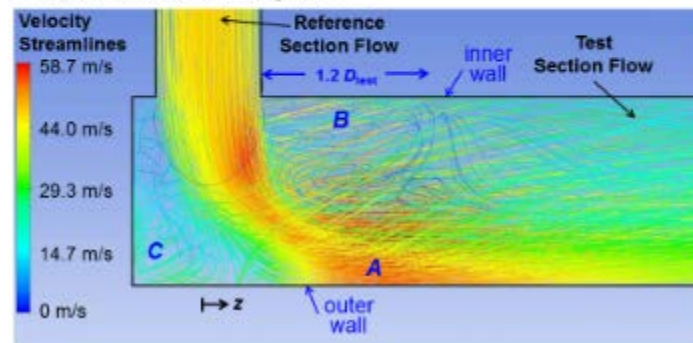

Scale-Model Smokestack Simulator (SMSS)



Air Intake Unit and Cone

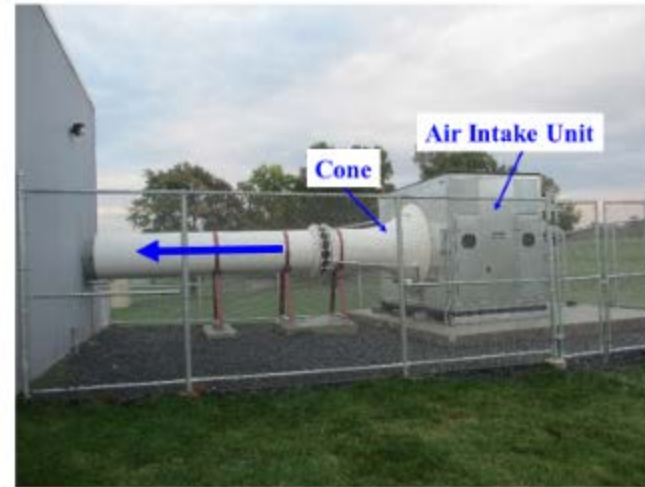

Air Intake Unit



Reference Section (SI Traceable Flow Measurement)



SMSS Reference Flow Meter



8 Path ultrasonic meter (USM)
 Installed after 17 D of straight pipe (good flow)
 Calibrated against NIST flow standards
 Determines bulk flow to 0.5%

Calibration of USM at CEESI in Colorado against NIST working standards

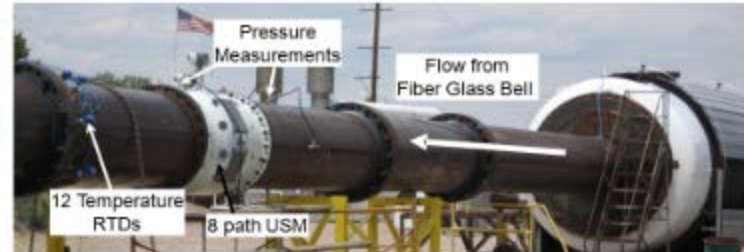

$$\phi = \frac{V_{\text{NIST}}}{V_{\text{USM}}} \quad \text{Calibration Factor}$$

Calibration Data

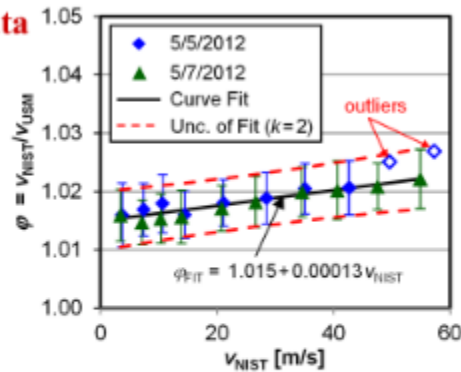

- Excellent Reproducibility < 0.075 %
- Expanded Uncertainty: 0.45 % to 0.58 %
- Best-ever calibration in air in this size

Test Section (Skewed, Swirling, Turbulent Flow)



Advanced Multi-path USM

- Gaussian Quadrature Methods can be used to compute flow velocity from average path velocities
- Symmetric, crossing paths can compensate for swirl effects
- CFD computations predicted that an 8 path USM can determine flow to better than 1%

Three Axis Automated Pitot Traversing Unit

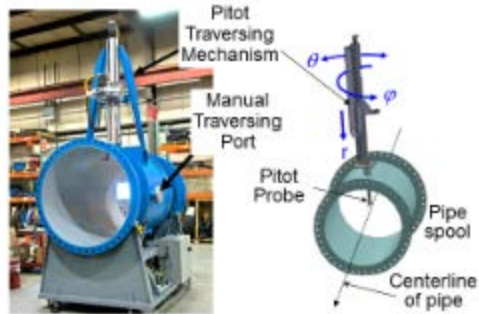

Traversing Axis	Maximum Range of Motion	Expanded Uncertainty
r	1.2 m	< 0.5 mm
θ	200°	< 1°
φ	360°	< 0.5°

Research Plans

- Determine the in-situ performance and uncertainty of smokestack flow measurement technologies in swirling flows with skewed velocities
 - EPA RATA using S-Probe (and other types of pitot probes)
 - CEMS flow meters (Ultrasonic Flow Meters)
- Research and develop alternative approaches for smokestack flow measurements
 - Long Wavelength Acoustic Flow Meter
 - Multi-chord pitot traverse methods with advanced integration techniques
 - Advanced Multi-path ultrasonic flow meters
 - Differential absorption LIDAR
 - Tracer Dilution Methods
- Develop benchmark data to validate CFD (Computational Fluid Dynamic) models used for scale-up to full sized smokestacks
- Proficiency Testing (Facility for RATA testers to prove their capabilities)

7.3.12 Performance Evaluation of Ultrasonic Flow Meters in NIST's Smokestack

Liang Zhang (National Institute of Metrology China)

Session: NIST Facilities and Flow Measurement Research

Accurate flow measurements are necessary to quantify the level of hazardous emissions from the smokestacks of fossil fuel burning power plants. Typical smokestack flow measurements are made using an ultrasonic flow meter (USM) with either a single diametric path or a symmetrically oriented dual path configuration. Due to the size of smokestacks the flow performance of USMs has not been quantified at the industrial scale. NIST designed and built a Scale-Model Smoke-stack Simulator (SMSS) that is 1/10th the industrial size to use as a test bed for research purposes. In this study, we use CFD to simulate the flow field in the SMSS. The results show that the SMSS generates asymmetric, swirling flows typical of industrial smokestacks. The computed flow field is subsequently used to predict the performance and characterize the measurement error of a single path, dual path, and variety of multi-path USMs as a function of the installation position and orientation, the path configuration, and the integration method. Measurement errors are categorized into integration error, transverse flow error, and axial flow error. The computational results predict that even using the same number of path, mid-radius USM have better performance than the diametric path USM, an 8 path USM using the OWICS integration scheme can determine the flow to better than 1% when the distance between the flowmeter and the T corner is above 3D.

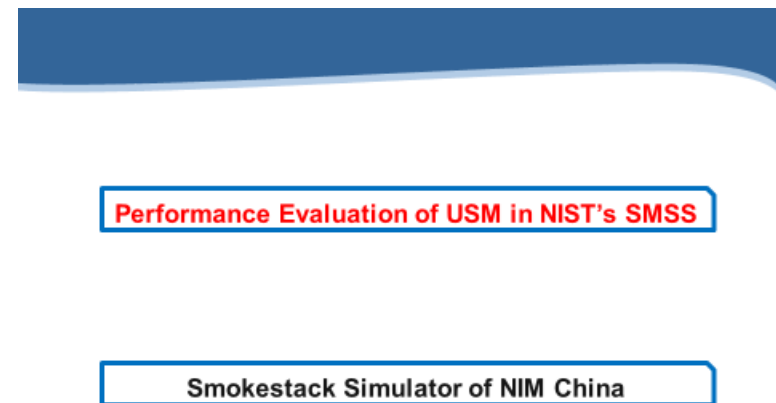
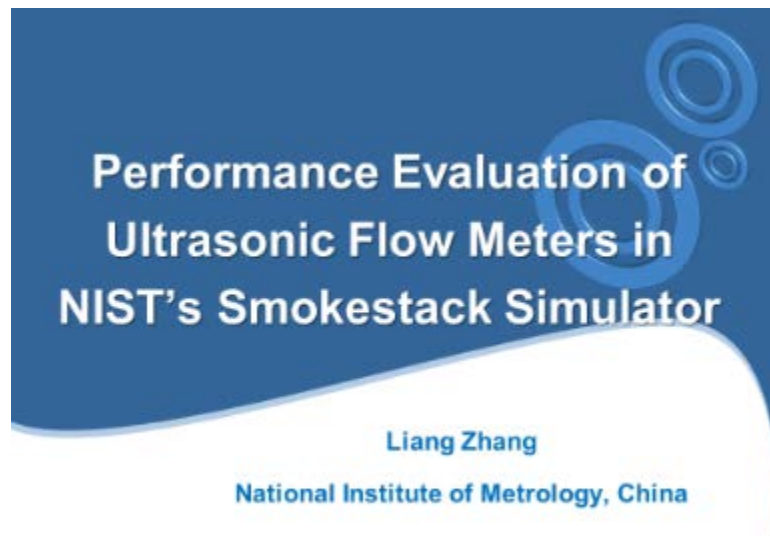

Flue Gas Ultrasonic Flowmeter

Path Velocity

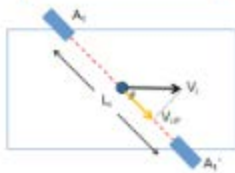

$$c + v_x \cos \theta = \frac{L}{t_{1A}}$$

$$c - v_x \cos \theta = \frac{L}{t_{2A}}$$

$$\Rightarrow v_x = \frac{L}{2 \cos \theta} \left(\frac{1}{t_{1A}} - \frac{1}{t_{2A}} \right)$$

Multi Path USM

Diametric Path

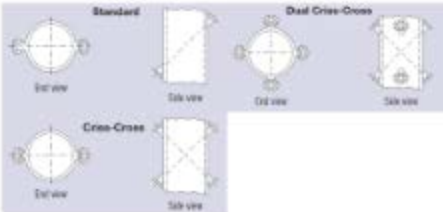

Mid-Radius Path

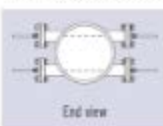

$$q_v = 2R^2 \sum_{i=1}^N W_i v_i$$

CFD Simulation Method

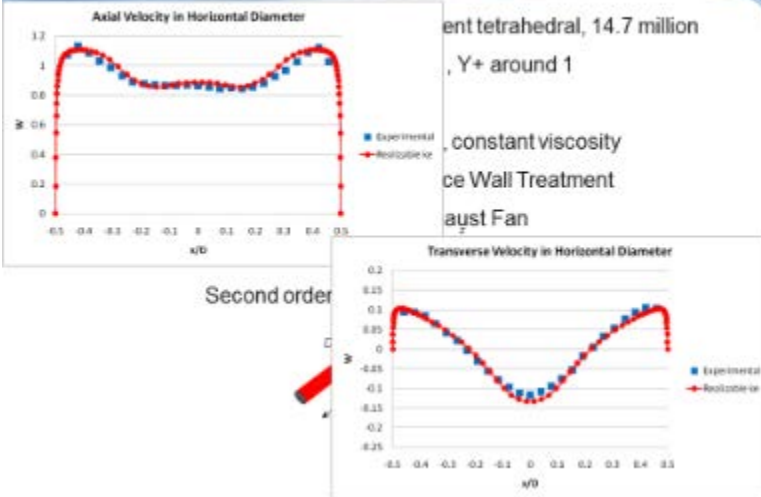

ent tetrahedral, 14.7 million
 , Y+ around 1
 constant viscosity
 ce Wall Treatment
 aust Fan

USM Evaluation Using CFD Simulation

- Calculate the flow field in the SMSS using CFD
- Estimate the performance of different USMs

- Give recommendation for the path layout of spool piece
- Provide users with a reference when selecting USM.
- Use for extrapolate the SMSS test result to real stack.

CFD Flow Field in SMSS

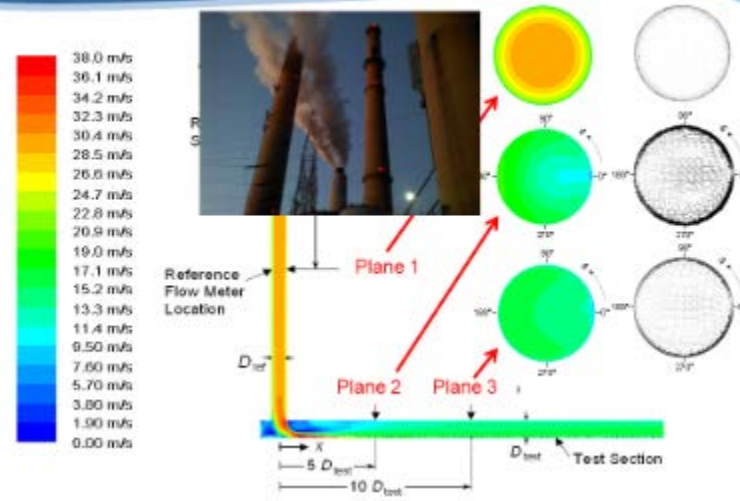

Mid-Radius USM Error Analysis Method

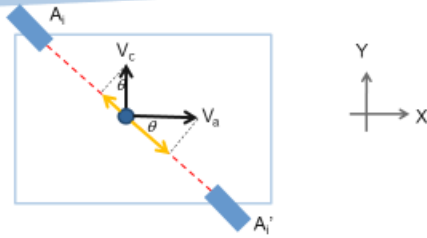

$$\begin{aligned}
 E &= Q_{USM} - Q_{act} \\
 &= \sum_{i=1}^n w_i (v_{ai} - v_{ci} \tan \theta) S_c - Q_{real} \\
 &= \left(\sum_{i=1}^n w_i v_{ai} S_c - Q_{real} \right) - \sum_{i=1}^n w_i v_{ci} \tan \theta S_c \\
 &= \left(\sum_{i=1}^n w_i v_{ai} S_c - \lim_{m \rightarrow \infty} \sum_{j=1}^m w_j v_{aj} S_c \right) + \left(\lim_{m \rightarrow \infty} \sum_{j=1}^m w_j v_{aj} S_c - Q_{real} \right) - \sum_{i=1}^n w_i v_{ci} \tan \theta S_c \\
 &= \left(\sum_{i=1}^n w_i v_{ai} S_c - \lim_{m \rightarrow \infty} \sum_{j=1}^m w_j v_{aj} S_c \right) - \lim_{m \rightarrow \infty} \sum_{j=1}^m w_j v_{cj} \cot \theta S_c - \sum_{i=1}^n w_i v_{ci} \tan \theta S_c
 \end{aligned}$$

Mid-Radius USM Error Analysis Method

Axial Velocity Integral Error

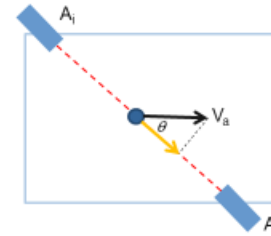

$$E_1 = \sum_{i=1}^n w_i v_{ai} S_c - \lim_{m \rightarrow \infty} \sum_{j=1}^m w_j v_{aj} S_c$$

Mid-Radius USM Error Analysis Method

Transverse Flow Projection Error

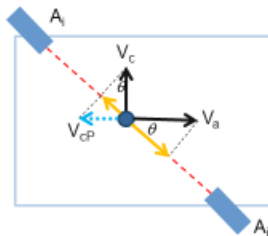

$$E_3 = - \sum_{i=1}^n w_i v_{ci} \tan \theta S_c$$

Mid-Radius USM Error Analysis Method

Axial Velocity Changing Error

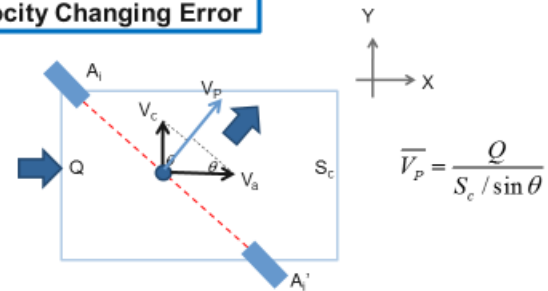

$$E_2 = - \lim_{m \rightarrow \infty} \sum_{j=1}^m w_j v_{cj} \cot \theta S_c$$

Mid-Radius USM Error Analysis Method

Cross Path/Plane Compensation

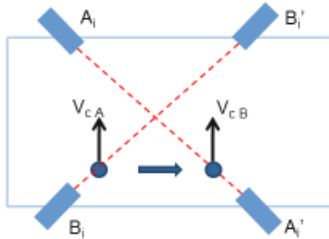

$$E_{AB} = \frac{E_{1,A} + E_{1,B}}{2} + \lim_{m \rightarrow \infty} \sum_{j=1}^m w_j \frac{v_{ej}^B - v_{ej}^A}{2} \cot \theta S_c + \sum_{l=1}^n w_l \frac{v_{el}^B - v_{el}^A}{2} \tan \theta S_c$$

$E_{1,AB}$
 $E_{2,AB}$
 $E_{3,AB}$

Velocity Impact on Measurement

□ In the velocity range of 10m/s to 25m/s, velocity dose not have obvious impact on USMs measurement errors

Cross Path **Diametric USM**

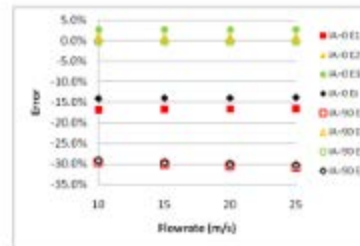

4*2 Path **Mid-Radius USM (Gauss-Jacobi)**

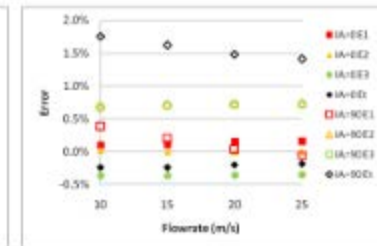

Flow Profile Correction Factor

Flow profile correction factors (FPCF)

$$K_1 = 1 + 0.2488 - Re^{-1} (3 \times 10^3 \leq Re \leq 10^4)$$

L. C. Lynnworth, 1989

$$K_2 = 1.119 - 0.011 \log(Re) (3 \times 10^3 \leq Re \leq 5 \times 10^6)$$

J. C. Jung et al., 2000

$$K_3 = 1 + 0.01 \sqrt{6.25 + 431 \cdot Re^{-0.237}} (3 \times 10^3 \leq Re \leq 10^4)$$

Korean Nuclear Society, 2001

PA45°, A **Single Path IA=0°**

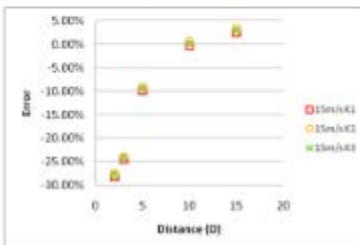

PA45°, AB **Cross-Path IA=0°**

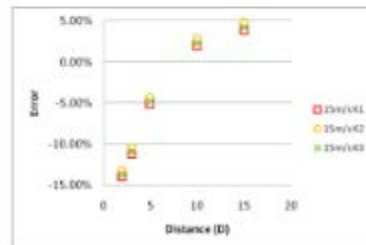

Error Analysis of Diametric USMs

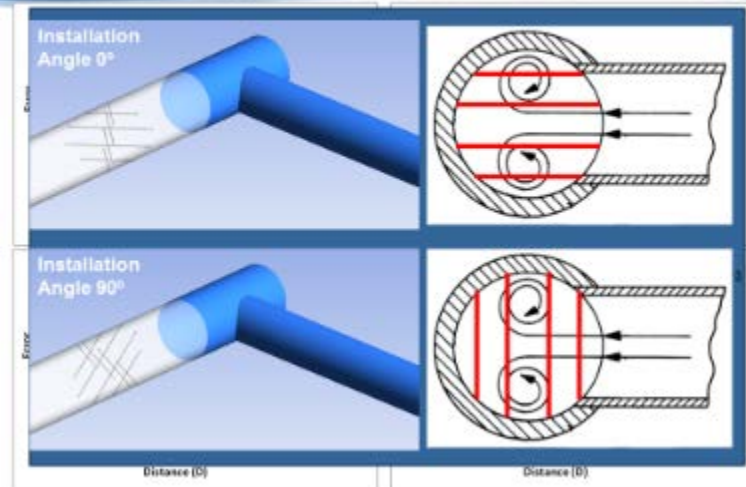

Integration Methods for Mid-Radius USMs

- Gauss-Jacobi and Optimized Weighted Integration for Circular Section (OWICS) are the most accurate integration method for USMs in circular pipes.
- For 2*2 path USM, the measurement error of OWICS USMs decrease quicker than Gauss-Jacobi USMs.

Path Angle 45°, 15m/s, IA=0°

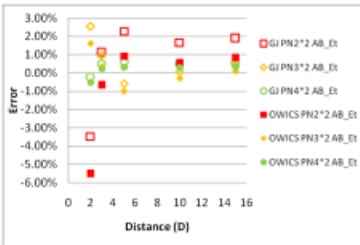

Path Angle 45°, 15m/s, IA=90°

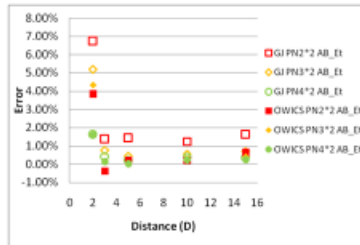

Error Analysis of Mid-Radius USMs-PN 2&4

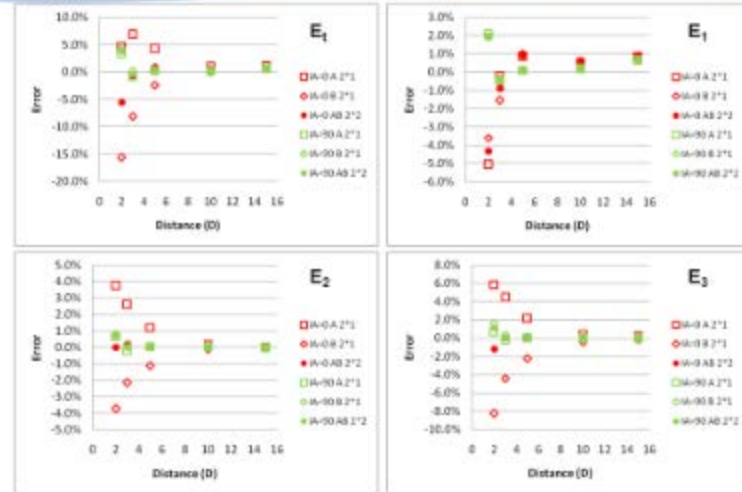

Error Analysis of Mid-Radius USMs-PN 4&8

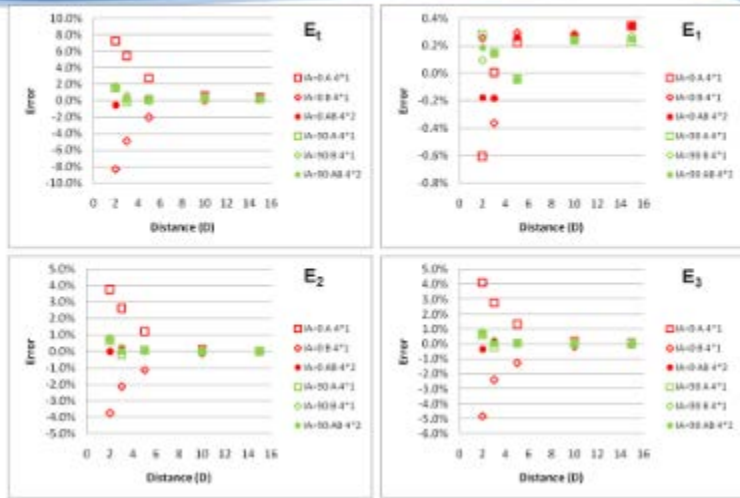

Error Analysis of Mid-Radius USMs-PN 3&6

- Staggered path USMs transverse flow error compensation effects depend on the flow field in the pipe and path layout.

OWICS, Path Angle 45°, 15m/s

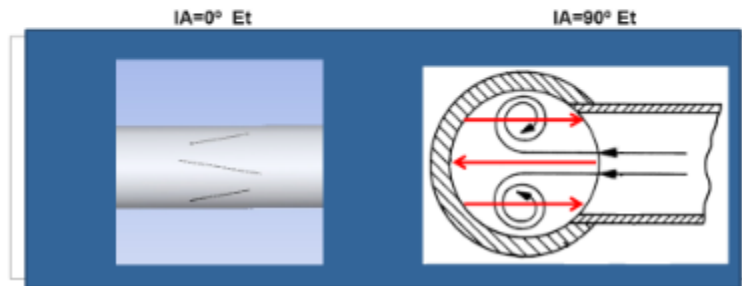

Impact of USM Path Angle

$$E = \left(\sum_{i=1}^n w_i v_{ai} S_c - \lim_{n \rightarrow \infty} \sum_{j=1}^m w_j v_{aj} S_c \right) - \lim_{n \rightarrow \infty} \sum_{i=1}^n w_i v_{ci} \cot \theta S_c - \sum_{i=1}^n w_i v_{ci} \tan \theta S_c$$

$$\approx \left(\sum_{i=1}^n w_i v_{ai} S_c - \lim_{n \rightarrow \infty} \sum_{j=1}^m w_j v_{aj} S_c \right) - 2 \sum_{i=1}^n \frac{w_i v_{ci} S_c}{\sin 2\theta}$$

- E_1 of different path angle USM depend on the flow field in the pipe
- 2-4 path single plane USM may have the minimum absolute $E_2 + E_3$ in 45° path angle
- For cross-plane USM, the $E_2 + E_3$ can be partially or completely canceled out, it depends on the distribution of transverse velocity in the pipe.

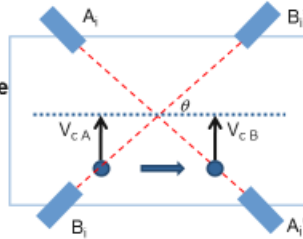

Conclusion

- For diametric USMs, using dual cross-path do not obviously enhance the USM performance compared to cross-path USM.
- Overall, the measurement errors of OWICS USMs are lower than Gauss-Jacobi USMs, especially when the path number is low
- Mid-radius path USMs measurement errors decrease with the path number increase
- For a single-plane USM, usually in 45° path angle, measurement error introduced by the transverse flow may reach the smallest value.
- Recommendation for spool piece: cross plane mid-radius USM using OWICS integration method

Conclusion

- Flowrate have little effect on the measurement errors of diametric path and mid-radius path USMs
- USMs measurement errors reduced with the increase of upstream straight pipe length
- Using cross-plane or cross-path USM configuration, measurement errors introduced by transverse flow can be totally or partially compensate
- Optimization of the USM installation angle will reduce the transverse flow velocity component in the path, especially for a single plane USM
- Diametric USMs integration errors are significantly greater than the mid-radius USMs

Performance Evaluation of USM in NIST's SMSS

Smokestack Simulator of NIM China

Smoke Stack Simulator of NIM

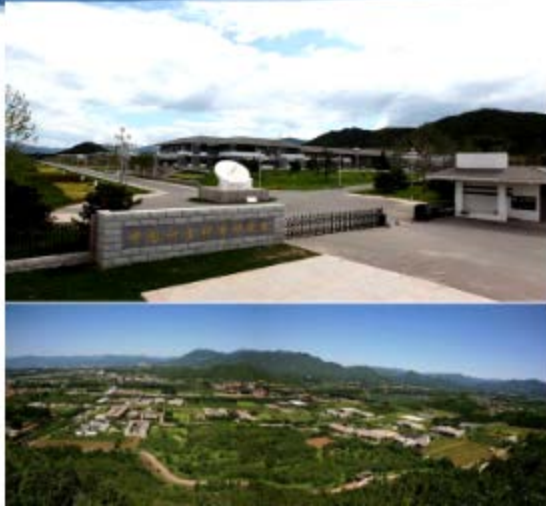

Smoke Stack Simulator of NIM

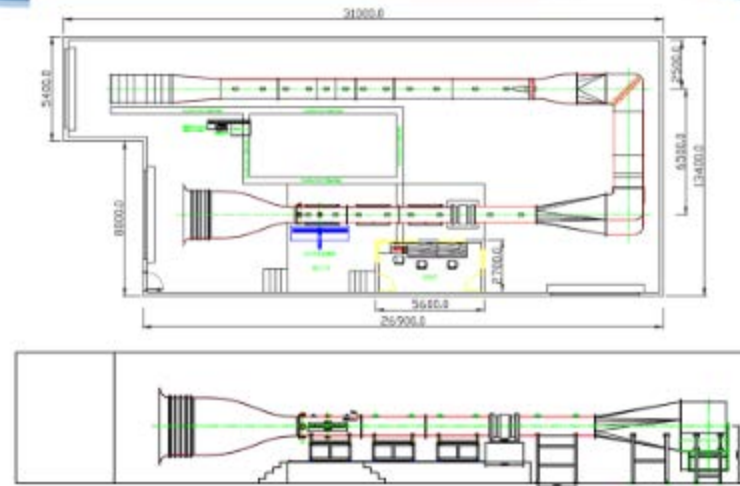

Components Smoke Stack Simulator

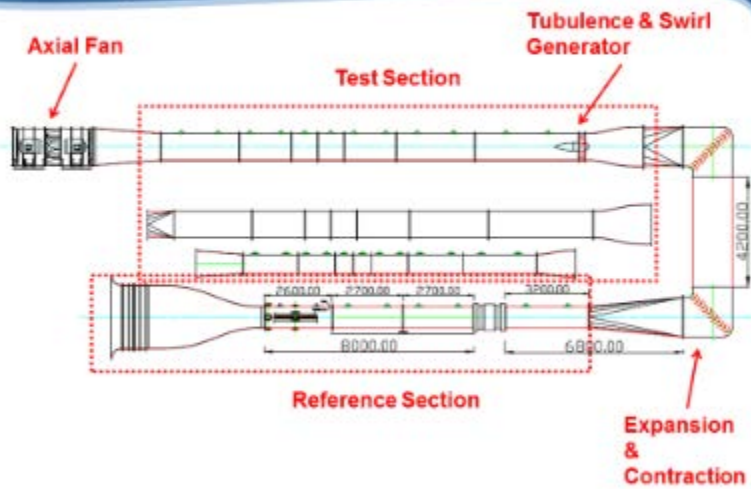

Primary Standard

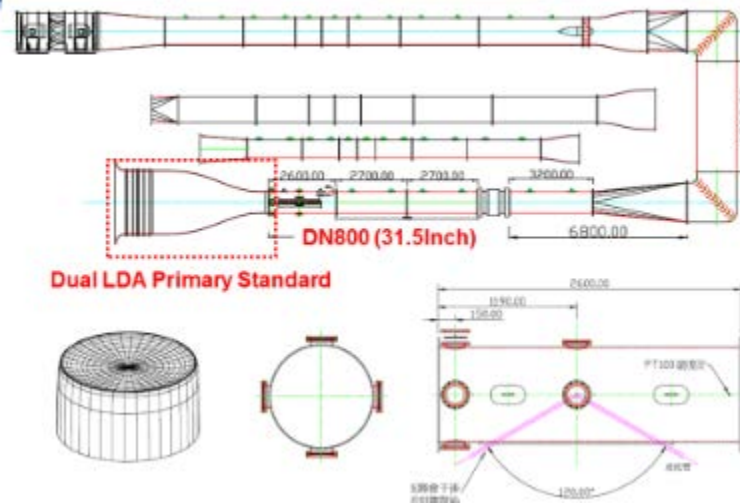

LDA Velocity Area Method

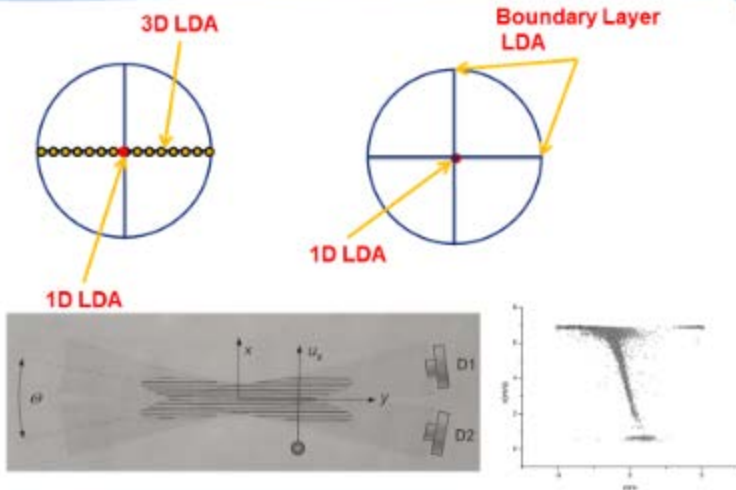

Pitot Tube Calibration Section

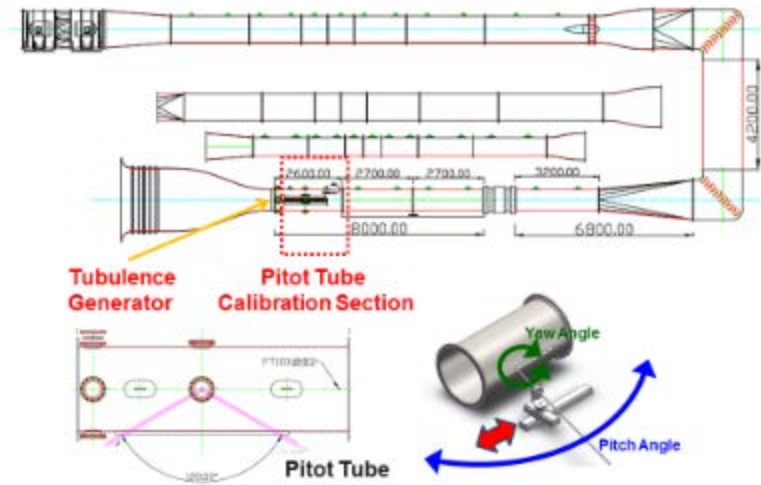

USM Working Standard

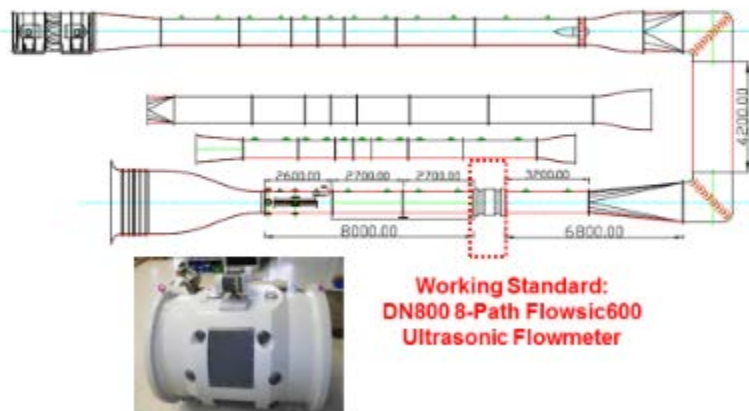

Test Section

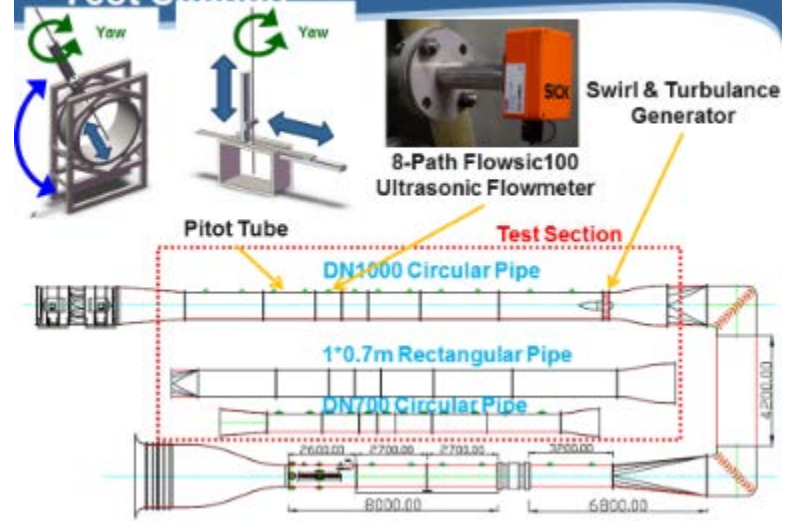

Completion Time: November 2015



7.3.13 Using the National Fire Research Laboratory (NFRL) as a Test Bed for Traceable CO₂ Measurements

Rodney Bryant (NIST)

Session: NIST Facilities and Flow Measurement Research

The newly built National Fire Research Laboratory (NFRL) is developing capabilities to assess and reduce GHG emissions measurement uncertainty. The facility has two major capabilities: 1) precisely generating natural gas fires up to 20 megawatts and 2) conducting accurate measurements of gas emissions from its exhaust system. The NFRL employs well-controlled and well-characterized natural gas burners as a quantitative source of CO₂. These burners provide a tool for assessing CO₂ emissions derived from fuel consumption measurements. The exhaust ducts of the NFRL are instrumented to continuously measure velocity, pressure, temperature, and composition of the flue gas, similar to a power plant continuous emissions monitoring system (CEMS). From these measurements CO₂ emissions are derived. The NFRL also has the capability to conduct flow RATAs for its exhaust ducts. By having well-characterized CO₂ emission sources, CEMS, and flow RATA measurements, the NFRL can perform cross checks of CO₂ emissions measurements by confirming a CO₂ mass balance for the facility. Therefore the facility is capable of evaluating current CEMS and RATA measurement methods under conditions similar to a real power plant as well as providing a test bed for developing and evaluating new methods.

Using the National Fire Research Laboratory as a Test Bed for Traceable CO₂ Measurements

Rodney Bryant, Aaron Johnson*, and Matt Bundy

National Institute of Standards and Technology
Fire Research Division
Sensor Science Division*

Workshop on Measurement Challenges and Metrology for Monitoring CO₂ Emissions from Smokestacks

NIST
Gaithersburg, Maryland
20-21 April 2015

Project Objective: To create a well-characterized and highly accurate reference measurement system at near industrial scale to serve as a test bed for carbon dioxide emissions measurements.

- Scale-Model Smokestack Simulator
- National Fire Research Laboratory
- Goal: Measure CO₂ emissions with ±1% uncertainty
- Reconcile the carbon mass balance at the source
 - Predicted Emissions vs Direct Emissions

The National Fire Research Laboratory (NFRL) is analogous to a stationary source, only smaller.

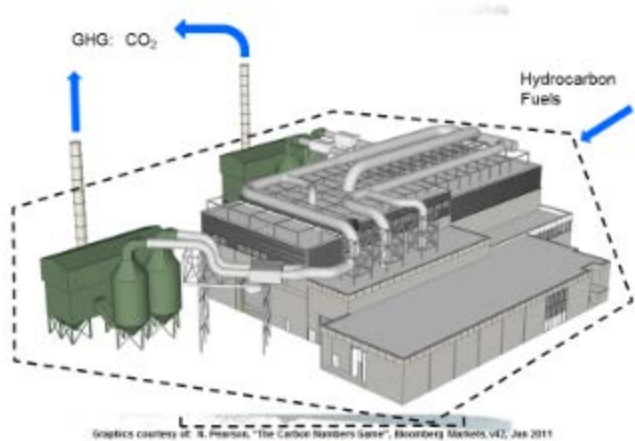

NFRL is a unique facility that provides large-scale fire and structural measurements to fire and building researchers.



- Support fire model validation studies
- Enable fire investigations
- Support post disaster and failure studies
- Enable advances in fire measurements, standards, and codes

- Heat released
- Flame spread
- Fire Spread
- Smoke movement and toxicity
- Early detection and abatement



The rate of heat released by a burning material is the primary measurement of the NFRL.

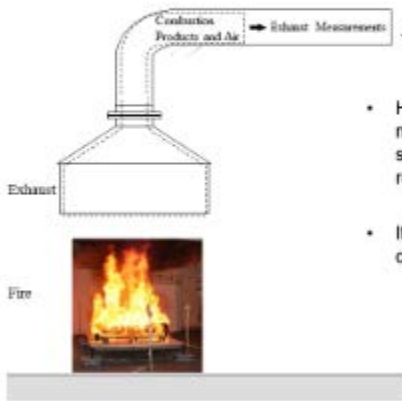

$$HRR = (\Delta H_c)_{Max_O_2} (\dot{m}_{O_2}^o - \dot{m}_{O_2})$$

- Heat Release Rate (HRR) is a measure of the potential for a fire to spread to other objects and beyond the room of origin
- It is derived from oxygen consumption calorimetry

Fire research and the emissions industry share a common problem: accurate characterization of flow and concentration in an industrial scale flue gas.

$$\dot{m}_i = Y_i \rho u A$$

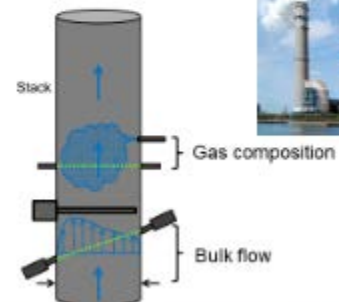

$$HRR = (\Delta H_c)_{Max_O_2} (\dot{m}_{O_2}^o - \dot{m}_{O_2})$$

Flow and Concentration

Routine emissions measurements are conducted in the exhaust duct at the roof of the facility.

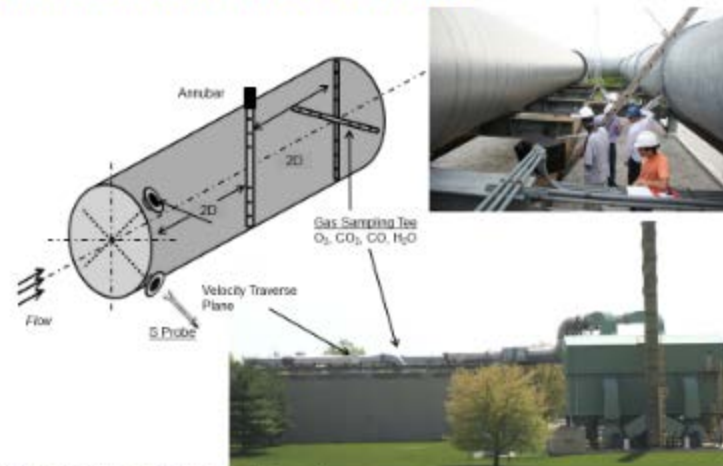

Flow path

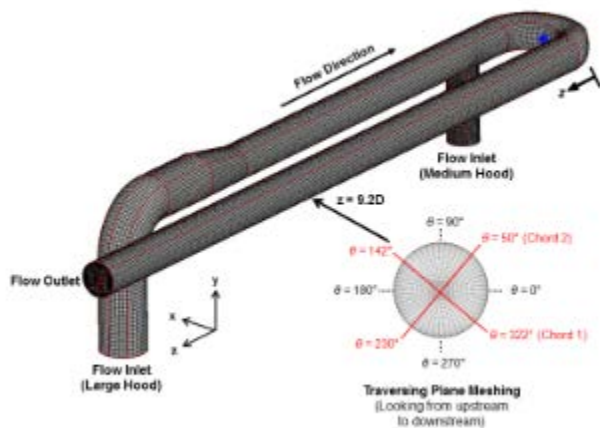

Independent flow RATAs to determine average stack gas velocity agreed to within 4%.

- Followed EPA test methods 1*, 2 and 2G
- Series 1: NIST
 - 1 chord at a time*
 - Scoping measurements*
 - $U_{VM,N} = \pm 2.6\%$
- Series 2: Stack Testing Company (STC)
 - 2 chords simultaneously
 - $U_{VM,N} = \pm 1.4\%$
- Annubar provides reference measurement between series 1 and 2

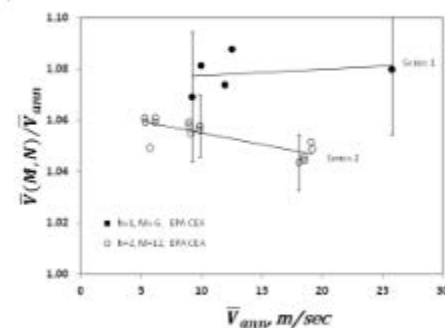

The flow profiles were confirmed with separate experimental trials.

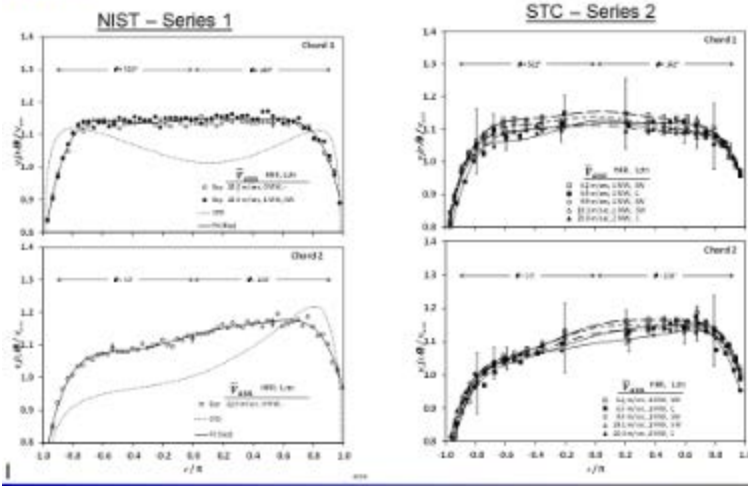

Better instrumentation and better calibrations result in lower uncertainty.

NIST - Series 1					STC - Series 2					
Measurement Component, h	Value	Relative Standard Uncertainty, $u(h)$	Non Dimensional Sensitivity Coefficient, s_h	Percent Contribution, %	Measurement Component, h	Value	Relative Standard Uncertainty, $u(h)$	Non Dimensional Sensitivity Coefficient, s_h	Percent Contribution, %	
Pulse Coefficient, C_p	0.031	0.008	1.0	86.1	Pulse Coefficient, C_p	0.715	0.022	0.020 ¹⁾	1.0	16.5
Pulse Var. δ (Deg)	2.48	0.023	0.02	0	Pulse Var. δ (Deg)	2.0	0.2	0.200	0.002	0
Pulse Differential Pressure, Δp (Pa)	125.26	0.008	0.5	0.5	Pulse Differential Pressure, Δp (Pa)	491.6	1.2 ²⁾	0.071	0.5	3.8
Gas Temperature, T_{30}	296	0.027	0.2	22.8	Gas Temperature, T_{30}	287.2	1.2 ²⁾	0.052	0.3	2.7
Duct Static Pressure, P_s (Pa)	190722	0.005	-0.5	0	Duct Static Pressure, P_s (Pa)	8000	1.0 ²⁾	0.001	-0.5	0.3
Gas Molecular Weight, M_w (kg/kmol)	28.207	0.005	-0.5	0	Gas Molecular Weight, M_w (kg/kmol)	28.11	0.1 ²⁾	0.003	-0.5	2.7
New Acid Velocity, v_a (m/s)	11.28	0.002	Standard Uncertainty		Gas Velocity, v_a (m/s)	28.41	0.33	0.009	Standard Uncertainty	
		0.0004	(Expanded Uncertainty)				0.48	0.013	(Expanded Uncertainty)	

NIST National Institute of Standards and Technology • U.S. Department of Commerce

The CFD simulation predicted the qualitative features of the flow and was therefore used to estimate the error due to measurement discretization.

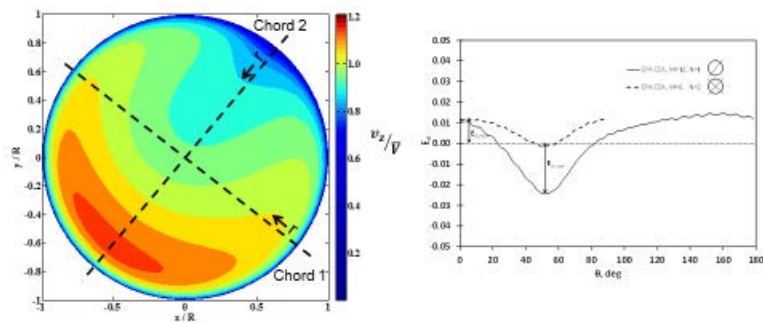

Flow and Concentration

NIST National Institute of Standards and Technology • U.S. Department of Commerce

NIST National Institute of Standards and Technology • U.S. Department of Commerce

Goal: Use the NFRL to demonstrate best practices for CO₂ emissions measurements with ±1% uncertainty.

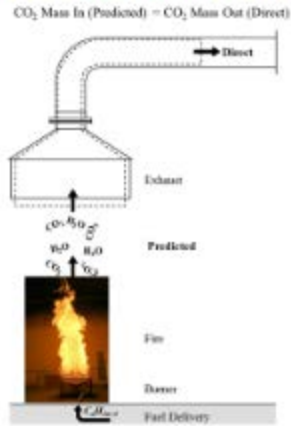

- Mass In = Mass Out
 - Input: metered flow of natural gas (traceable to primary flow standard and gas composition standards), i.e. metered flow of C atoms
 - Assume 100% conversion of C atoms to CO₂
 - Measurement: CO₂ mass flow rate

The distribution of the data from separate experimental trials was within ±7%.

- Many of the point velocity traverse experiments were run with the natural gas fire.
- Direct: Emissions
 - Flue gas measurements of flow and concentration
- Predicted: Fuel
 - Flow and composition measurements of natural gas supply

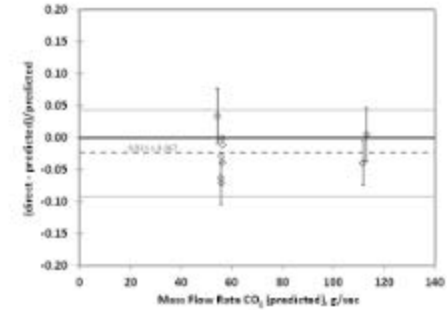

The natural gas burner system provides a precision source of CO₂; duct/stack diameter measurements are a significant source of uncertainty for flue gas measurements (CEMS).

Predicted (Fuel)				Direct (Flue)					
Measurement Component, x	Value	Relative Standard Uncertainty, u(x)/x	Non Dimensional Sensitivity Coefficient, s	Percent Contribution, %	Measurement Component, x	Value	Relative Standard Uncertainty, u(x)/x	Non Dimensional Sensitivity Coefficient, s	Percent Contribution, %
Gas Volume Flow Rate, V _g (m ³ /sec)	0.00283	0.0009	1.0	22.9	Exhaust Gas Mass Flow Velocity, V _g (m/sec)	20.91	0.0056	1.0	9.9
Gas Pressure, P _g (Pa)	187719	0.0006	1.0	16.3	Exhaust Duct Diameter, d (m)	1.504	0.0079	2.0	77.6
Gas Temperature, T _g (K)	290.65	0.0007	-1.0	19.0	Exhaust Gas Mean Density, ρ _g (kg/m ³)	1.047	0.0034	1.0	3.6
Gas Compressibility, Z _g (-)	0.9958	0.0005	-1.0	1.6	CO ₂ Net Volume Fraction - Analytical, X _{CO2-net} (m ³ /m ³)	0.008159	0.0053	1.0	8.9
Gas Carbon Fraction, X _{CH4} (mol/mol)	1.042	0.0020	1.0	26.2	Exhaust Gas H ₂ O Volume Fraction, X _{H2O-net} (m ³ /m ³)	0.007947	0.0031	0.05	0
CO ₂ Molecular Weight, M _{CO2} (g/mol)	44.0095	0.0000	1.0	0	Exhaust Gas Molecular Weight, M _g (g/mol)	28.7334	0.0001	-1.0	0
Ideal Gas Constant, R (J/molK)	8.3144	0.0002	-1.0	0	CO ₂ Molecular Weight, M _{CO2} (g/mol)	44.0095	0.0000	1.0	0
Burner Conversion Efficiency, η (-)	1.0000	0.0005	1.0	14.0	Direct CO₂ Emissions, V_{CO2} (g/sec)	107.3	0.0179		(± 0.88%)
Predicted CO₂ Emissions, V_{CO2} (g/sec)	112.4	0.0088							(± 0.88%)
		(0.0088)		(± expanded)					(± expanded)

CO₂ emissions derived from O₂ concentration measurements agreed well with direct CO₂ measurements.

- If a CO₂ analyzer is not present, procedures to use O₂ concentration measurements exist
- Based on emission factors for natural gas
- Larger uncertainty in emission factors
- 40 CFR Pt75 – Appendix F – Conversion Procedures

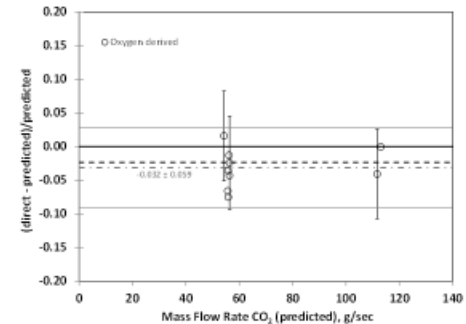

Fuel Factors computed from the proportions of O₂ and CO₂ agree with the default value, confirming the quality of the gas concentration measurements.

- Predicted; fuel (natural gas) composition measurements
- Direct; flue gas concentration measurements
- EPA Method 3b – Gas Analysis for the Determination of Emission Rate Correction Factor or Excess Air

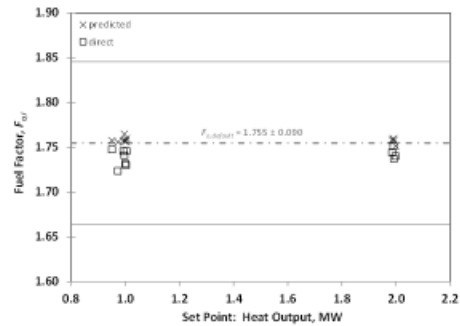

National Fire Research Laboratory



Summary

- The NFRL has similar measurement systems and functions to a stationary source. It is a near-industrial scale analog of a stationary source – a CO₂ emissions measurement test bed.
- The NFRL has been used to simulate some of the practices of the source emissions measurement industry. The goal is to demonstrate best practices for achieving ±1% uncertainty CO₂ emissions measurements.
- Preliminary results demonstrate that the NFRL has the capability to evaluate CO₂ emissions measurements with mass balance experiments.
 - Fuel derived emissions measurements
 - Direct emissions measurements

7.3.14 Is a Long-Wavelength Acoustic Flowmeter Feasible for Smokestacks?

Keith Gillis (NIST)

Session: NIST Facilities and Flow Measurement Research

Conventional gas flow measurements conducted in large ducts (such as the smokestack of a coal-burning power plant) have uncertainties of 5 % to 20 %. Consequently, the quantity of pollutants (sulfur dioxide, mercury, nitrogen oxides, and carbon dioxide) emitted by such ducts have equally large uncertainties. As part of NIST's Greenhouse Gas and Climate Science Measurements Program, we are testing long-wavelength acoustic flow meters (LWAFs) to reduce this uncertainty. LWAFs measure the average volume flow of flue gases in smoke stacks. The measured volume flow can be combined with measurements of the flue gas's pressure, temperature, and composition to determine the mass of pollutants emitted by the stack.

To test LWAFs, we constructed a 1:100 scale model (10 cm diameter) test facility equipped with a variable-speed fan. The model LWAF determined the speed of sound in ambient air with a standard uncertainty of 0.01 %. Within this uncertainty, the speed of sound agrees with the value calculated from NIST's REFPROP database.

The same LWAF determined the average flow velocity. It agreed, within ± 1 %, with the velocity determined from a NIST-calibrated flow standard upstream from the LWAF. This good agreement was maintained for flows up to 25 m/s, even after various swirl-inducing bends were inserted between the flow standard and the LWAF. Similar uncertainties were obtained with highly distorted flows generated by placing obstructions upstream of the LWAF.

A preliminary test of the scalability of the technique using a 20 cm diameter LWAF with the same variable-speed fan and flow reference gave similar uncertainties in the measured flow up to 6 m/s (limited by the fan). To further verify the scalability of the method, we will test LWAFs in NIST's 1:10 Scale-Model Smokestack Simulator (SMSS).

Is a long-wavelength acoustic flowmeter feasible for smokestacks?



Keith A. Gillis

Fluid Metrology Group
Sensor Science Division
National Institute of Standards and Technology

Measurement Challenges and Metrology for
Monitoring CO₂ Emissions from Smokestacks
April 21, 2015

Anatomy of a nearby coal-burning power plant



Collaborators

Lee Gorny
Aaron Johnson
Liang Zhang
John Wright
Mike Moldover

Anatomy of a nearby coal-burning power plant

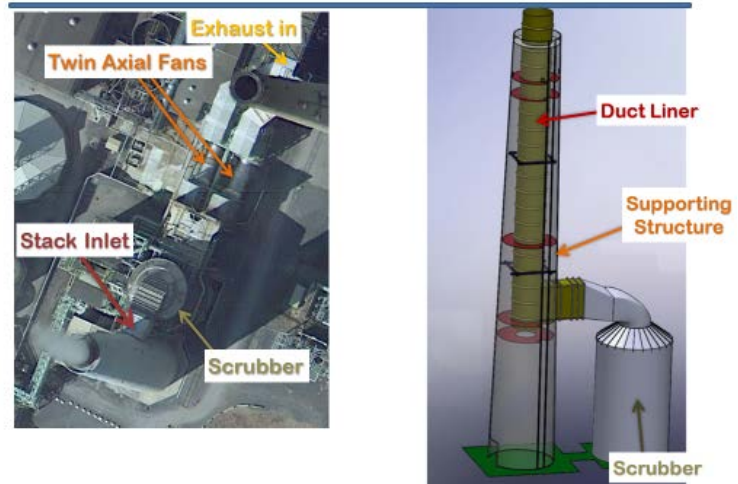

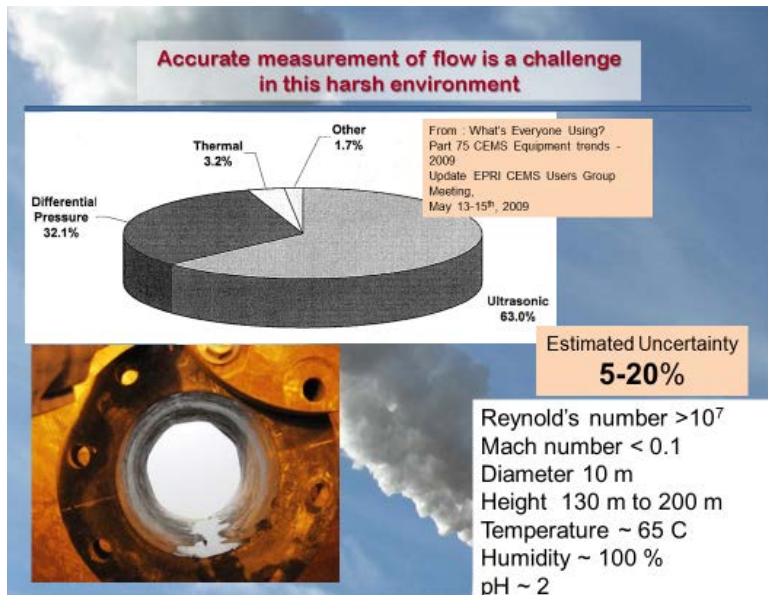

introduction — **LWAF principle** — NST's LWAF — distorted flow — conclusions —

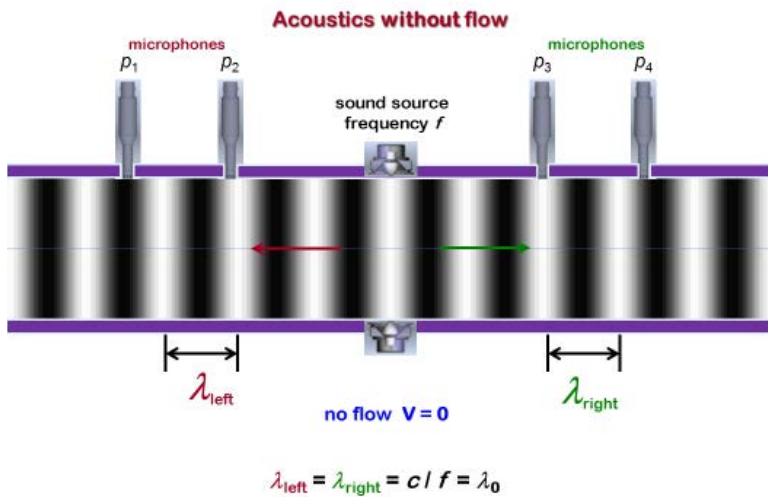

introduction — LWAF principle — NST's LWAF — distorted flow — conclusions —

Measuring flow in a smokestack

Are there alternative methods to measure complicated flows in harsh environments?

Is acoustics a good hammer?



...even for large-scale flows?



introduction — **LWAF principle** — NST's LWAF — distorted flow — conclusions —

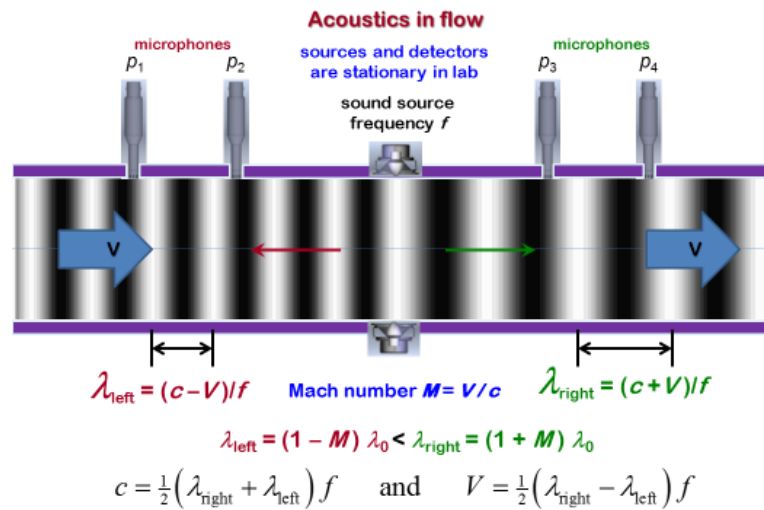

Measuring flow with sound

History of the Long-wavelength acoustic flowmeter (LWAF)

- plane wave propagation in a pipe is predicted to be insensitive to temperature and velocity profiles, including swirl and turbulence

[B. Robertson, "Effect of arbitrary temperature and flow profiles on the speed of sound in a pipe", *J. Acoust. Soc. Am.* 62, pp. 813-818 (1977).]

- prototype LWAF is described and evaluated

[J.E. Potzick and B. Robertson "Long-wave acoustic flowmeter," *ISA Transactions* 22, pp. 9-15 (1983); J. Potzick, "Performance evaluation of the NBS long-wave acoustic flowmeter," *Rev. Sci. Instrum.* 55, 1173 (1984).]

- NBS LWAF instrument is patented (May, 1984)

[Long wavelength acoustic flowmeter, US Patent 4,445,389]

- VTT in Finland develops a small commercial instrument (~2000)

A Long Wavelength Acoustic Flowmeter (LWAF) measures flow with low frequency sound.



A complex 3-dimensional, spatially-varying, flow profile exists within the duct.

10

A Long Wavelength Acoustic Flowmeter (LWAF) measures flow with low frequency sound.

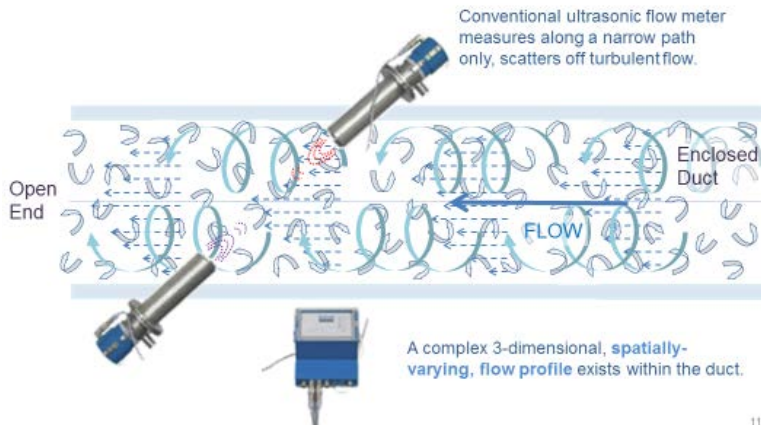

11

A Long Wavelength Acoustic Flowmeter (LWAF) measures flow with low frequency sound.

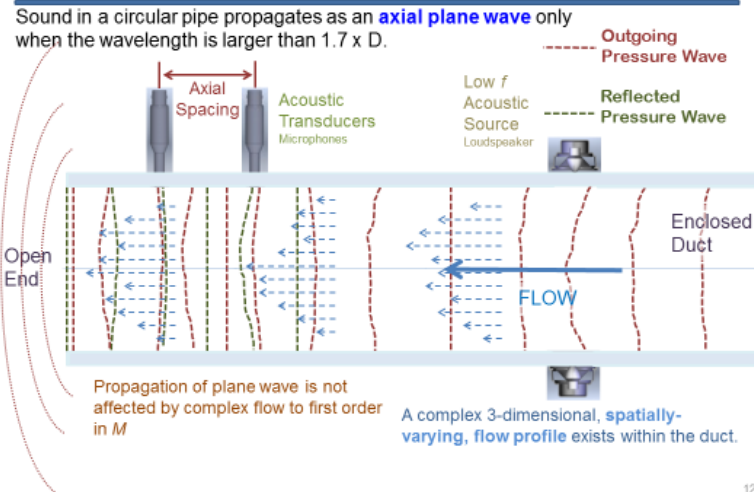

12

A Long Wavelength Acoustic Flowmeter (LWAF) measures flow with low frequency sound.

Sound in a circular pipe propagates as an **axial plane wave** only when the wavelength is larger than $1.7 \times D$.

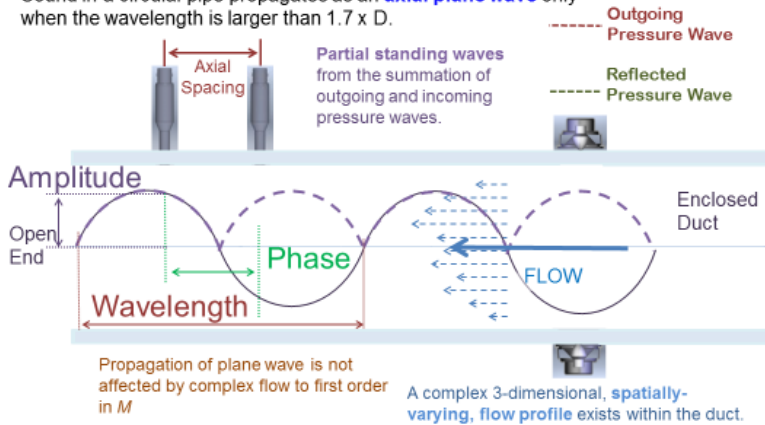

13

Measuring flow with sound

Acoustic flow metering methods measure phase to determine the convective speed of sound ($c_0 + V$).

Flow velocities are **< 10 %** of the speed of sound for a power plant. Therefore, a measurement of **flowrate** with **1 %** uncertainty, requires that the **convective speed of sound** must be measured to better than **0.1 %**.

Acoustic measurements of flow

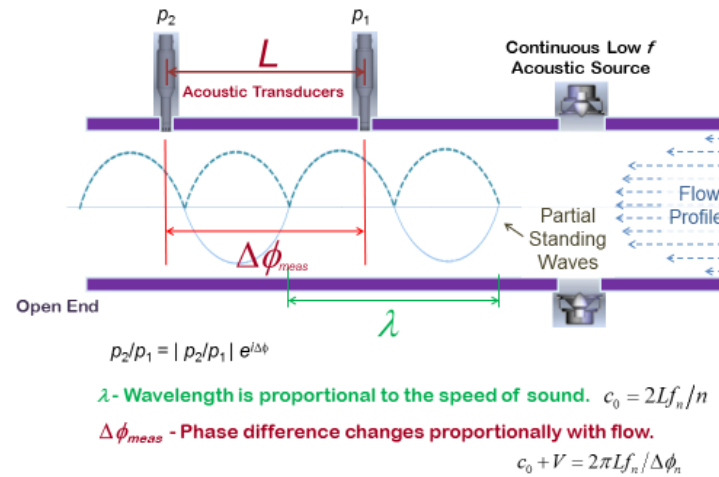

NIST's long-wavelength acoustic flowmeter

We constructed a 1/100th scale (10 cm diameter) laboratory flow facility to study the performance of LWAF. Target uncertainty is 1%.

Our LWAF met target performance: (spoiler alert)

- in symmetric flows up to 25 m/s
- in distorted flows with swirl, vortices, and recirculation up to 25 m/s
- scaling to 1/50th (20 cm diameter) up to 6 m/s (limited by fan)
- preliminary measurements in humid air

Long-wavelength acoustic flowmeter test facility

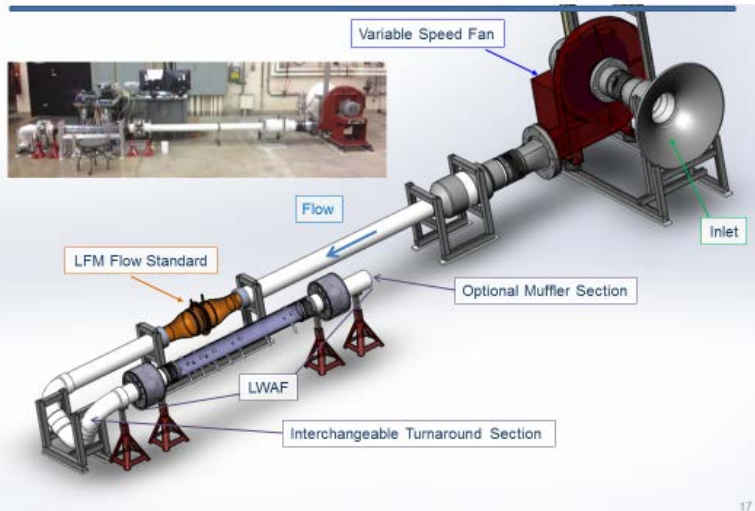

LWAF measurements in undistorted flow

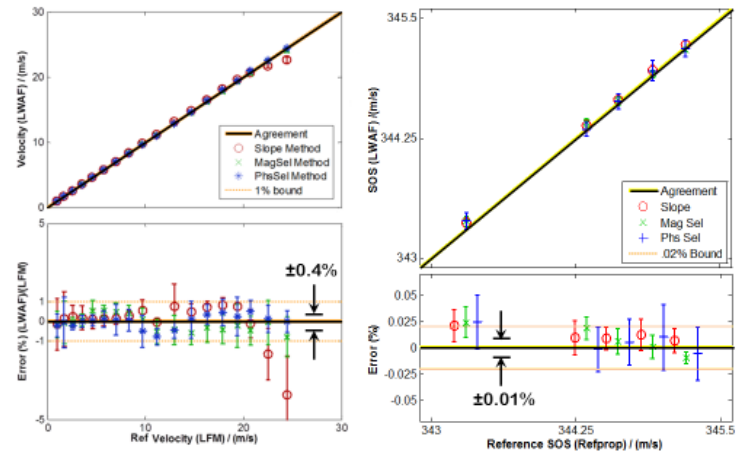

Measurements in distorted flow

Demonstrate accurate measurements with LWAF in distorted flow:

- T section and bends in the pipe to generate swirl
- obstructions to generate asymmetric flow

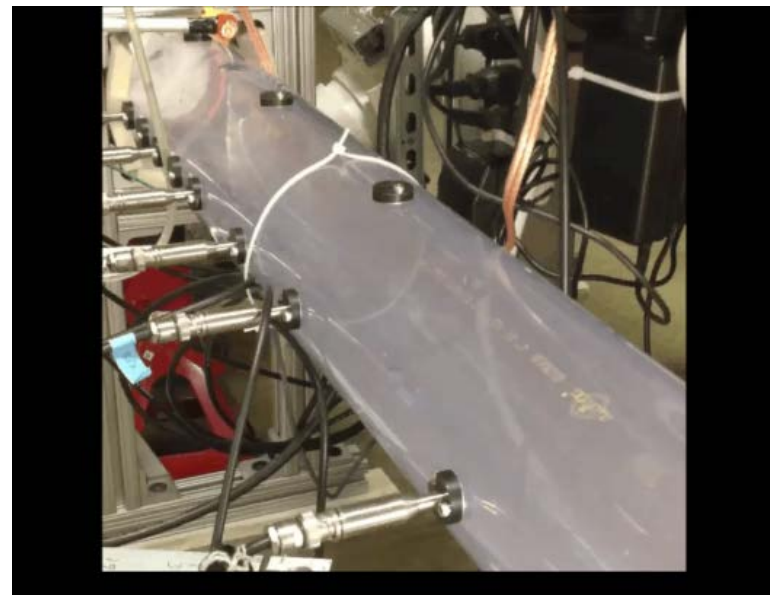
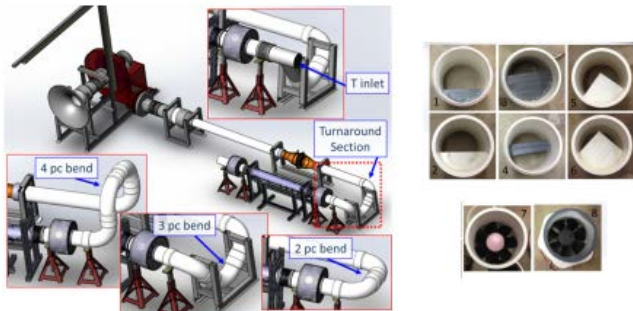

Use CFD to visualize distorted flows

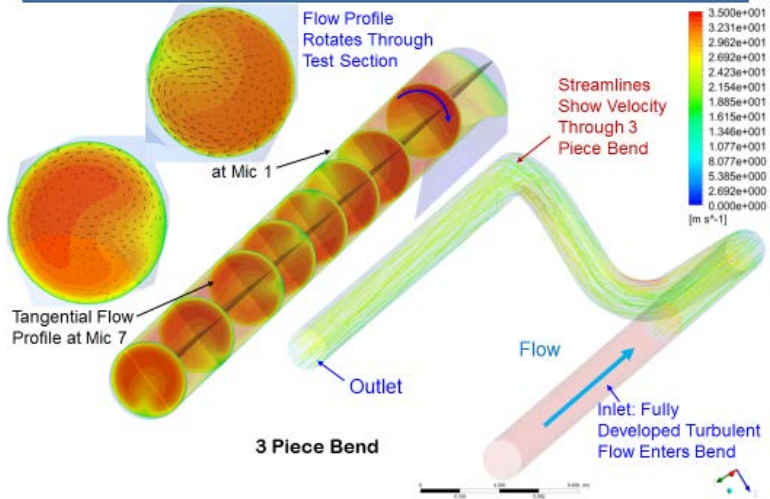

Measurements in distorted flow: It works!

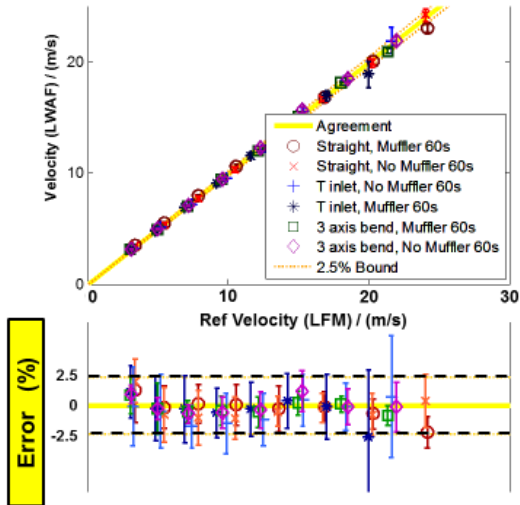

Use CFD to visualize distorted flows

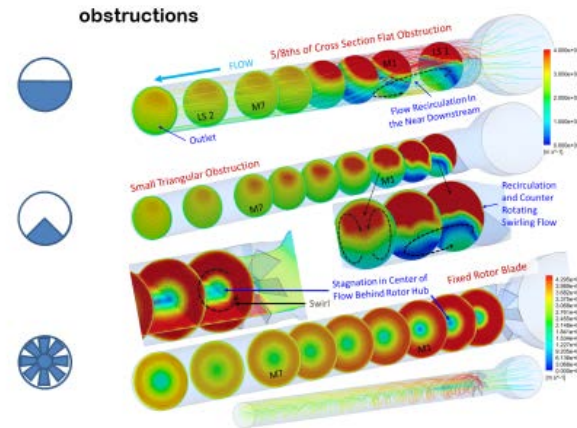

Measurements in distorted flow: It works!

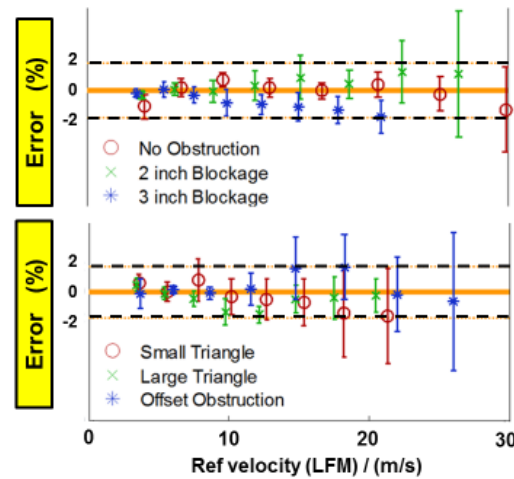

Scaling up to 20 cm diameter: It works!

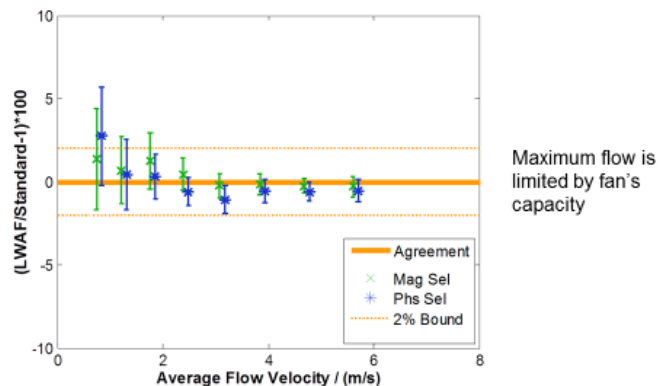

LWAF performance summary

The NIST 1/100th scale (10 cm diameter) LWAF facility was constructed to assess the performance and scalability

- $u(V) \approx 0.4\%$ and $u(c_0) \approx 0.01\%$ in symmetric flows up to 25 m/s
- $u(V) \approx 1\%$ in distorted flows with swirl, vortices, and recirculation up to 25 m/s
- scaling to 20 cm diameter: $u(V) \approx 1\%$ up to 6 m/s
- preliminary tests in humid air are promising

Challenges of implementing LWAF in smokestacks

- The LWAF approach is conceptually well suited for measuring ducted, low speed, highly distorted flows.
- Several difficulties arise when scaling the method to a power plant :
 - Low frequency operating conditions (~20 Hz)
 - Sound generation difficulties -> use noise correlations instead?
 - Signal to noise
 - Uncertain reflections from opening
 - Sound propagation through fog (dissipation, scattering)
 - Reynolds number scaling ($2 \times 10^5 \rightarrow 2 \times 10^7$)
 - Compliance of duct liner (lowers apparent speed of sound)

Thank you for listening!

7.4 Appendix D: Stationary Source Sampling & Analysis for Air Pollutants (SSSAAP) Conference

38th Annual SSSAAP Conference (March 6, 2014, Point Clear, Alabama) Stack Gas Velocity Measurements Session (Co Chairs: Rodney Bryant and Aaron Johnson, NIST)

Abstract

Emission rates of regulated pollutants are determined by multiplying the measured pollutant concentration by the total measured flow in a stack. Large uncertainties in either concentration or flow measurements result in large uncertainties in reported emissions. Hence, accurate flow measurements are critical for quantifying pollutant emissions from the smokestacks of fossil fuel burning sources. The National Institute of Standards and Technology (NIST) has expanded its capabilities to address the need for accurate air pollutant measurements by constructing a new facility - the Scale Model Smokestack Simulator (SMSS), and by expanding an existing facility - the National Fire Research Laboratory (NFRL). The objectives of this breakout session include:

- 1) present capabilities and opportunities of the NIST facilities,
- 2) discuss use of SMSS for establishing flow traceability and assessing the accuracy of pitot traverse methods with RATA testing,
- 3) enable use of NFRL as a test bed for accurate determination of carbon dioxide emissions,
- 4) identify issues surrounding velocity probe calibrations (standard pitot, S-probe, and 3D) and performance under different flow profile regimes, and
- 5) facilitate discussion of industry's perspective on flow measurement challenges and improvements needed to achieve higher levels of accuracy.

Anticipated outcomes of this session were to establish a continuing dialogue regarding the real world issues of stack gas velocity measurements and flow traceability, and to identify continuing stakeholders' concerns with improved stack gas velocity measurements.

Summary

Members of the stack testing industry, along with staff from the U.S. Environmental Protection Agency (EPA) and NIST gathered to discuss the topic of stack gas velocity and flow measurement methodologies. The session was well attended with 40 to 50 participants. NIST

began the session by providing a brief overview of its Greenhouse Gas and Climate Science Measurements Program and descriptions of its flow measurements research and instrument evaluation efforts. The long term objective of this program is to enhance measurement accuracy for greenhouse gases in the U.S. by:

- improving the accuracy of stack flow measurements,
- providing standards as needed by the industry, and
- transferring improved measurement technologies to other government agencies and the private sector.

The rationale for this measurement science research is the need for higher accuracy measurement capabilities for improved greenhouse gas mitigation efforts in the U.S. and with other countries.

NIST provided descriptions of three major facilities, the Scale Model Smokestack Simulator (SMSS), the Wind Tunnel Facility, and the National Fire Research Laboratory (NFRL). SMSS is a facility capable of evaluating the performance of flow RATA measurement instruments and methods, and flow CEMS devices. The SMSS can simulate flow conditions potentially impacting stack gas velocity measurement accuracy and quantify the impact of these conditions on measurement performance. Next, they presented an overview of NIST's low turbulence wind tunnel facilities, with capabilities to calibrate air speed measurement devices. They provided recent results from an investigation of the effect of yaw angle on S-probe calibration accuracy. The NFRL is a reduced-scale analog of a stationary emissions source, and its capabilities to precisely generate and measure carbon dioxide were explained. As such, it is a test bed for accurate greenhouse gas measurements. Further details on these facilities are available from <www.nist.gov>.

Stack-testing industry representatives raised issues impacting their field, and provided real world perspectives on why stack gas velocity measurements are challenging. These difficulties covered a range of issues, some inherent to the equipment and testing methodologies that should be addressed. Industry feedback pointed to the following measurement issues:

- S-probe calibration coefficients variability– anywhere from 0.72 to 0.84;
- accurate determination of stack cross sectional area;
- site conditions such as weather, vibrations, particulates, etc.;
- operator skill.

Industry feedback also generated the following suggestions for NIST. They called for the need to consider the impact of environmental and operational conditions, such as vibrations, sampling locations, weather, particulates, and others, on measurement accuracy. They raised the need to reduce blockage effects for probe calibrations, and to account for turbulence and high temperature (viscosity) representative of real stack flows during probe calibrations.

Participants noted the importance of continued discussions. The EPA, in particular, welcomed NIST's involvement to address important measurement challenges. They expressed interest in

working with NIST and representatives at the session to set agendas for future workshops. Session chairs expressed intent to bring back to NIST, the status of issues most important to the stack testing community. The session was an important step forward in identifying issues, convening representatives with diverse perspectives, and seeking common ground to seek solutions.