

ADDITIVE MANUFACTURING ROUND ROBIN PROTOCOLS: A PILOT STUDY

Shawn Moylan¹, Joshua Land², Antonio Possolo¹

¹ National Institute of Standards and Technologyⁱ
Gaithersburg, MD, USA

² University of Maryland College Park
College Park, MD, USA

Abstract

As the number of users of additive manufacturing (AM) steadily increases, and considering their demand for material and process specifications, the need for standard protocols for round robin studies is increasing accordingly. Researchers at the National Institute of Standards and Technology (NIST) have conducted and participated in several AM round robin studies with the aim not only to characterize the AM process, and material but also to improve the understanding of AM round robin studies themselves. One simple study, a pilot round robin study investigating geometric performance of NIST-owned consumer-grade 3D printers, provides excellent examples of typical results and lessons learned. While individual printers produced relatively consistent results, there was significant variability between the printers. This variability existed despite best efforts to ensure participants followed consistent procedures in building the test parts. Further, the variability made it apparent that collecting pedigree data from each build was required to draw any conclusions about potential causes of the variability.

1. Introduction

As additive manufacturing (AM) technologies mature, industry is looking for standards [1]. Of primary interest are AM material and process specifications to improve efficiency of purchasing AM parts, receiving AM parts from suppliers, or certifying AM parts for critical applications. Thorough material and process specifications will need variability, repeatability, or reproducibility data in addition to machine parameters and expected material properties. Round robin studies provide exactly this information, and therefore will be a valuable tool to be used throughout the industry.

A round robin study is an experimental methodology where tests are performed independently multiple times by multiple participants and the results are analyzed statistically to assess their variability. This type of study is often used to determine the repeatability and reproducibility of a "process". The process is often a measurement method but can also be the fabrication of an artifact using a well-defined procedure (e.g., an additive manufacturing process). Round robin studies may also be used to verify that results from a new process agree with those from an existing, trusted process.

ⁱ Official contribution of the National Institute of Standards and Technology (NIST); not subject to copyright in the United States. The full descriptions of the procedures used in this paper require the identification of certain commercial products. The inclusion of such information should in no way be construed as indicating that such products are endorsed by NIST or are recommended by NIST or that they are necessarily the best materials, instruments, software or suppliers for the purposes described.

As the national metrology institute for the United States, NIST has significant experience in interlaboratory studies, key comparisons, and round robin studies to compare measurement methods. However, there was no existing guidance on conducting round robins for AM (at NIST or anywhere in the literature), and there was very little guidance on round robin studies focused on any manufacturing process. To gain insight into conducting AM-based round robins, NIST has undertaken several, parallel round robin efforts. NIST provided funding and participated in a study led by the Edison Welding Institute (EWI) for the Additive Manufacturing Consortium focused on material properties of IN625 [2]. NIST also led a round robin study of the tensile properties of an AM Cobalt-Chromium alloy produced by powder bed fusion processes (report still being drafted). NIST was a participant in a study organized through the International Academy for Production Engineering (CIRP) to study Uniform Numbering System for Metals and Alloys (UNS) S15500 (15-5) stainless steel (report still being drafted). While the results of these studies, the properties of AM materials and their variability, were certainly important and valuable to the AM industry, NIST's primary goal was to learn more about how to better conduct such studies.

Full scale round robin studies are expensive and very time-consuming, but we were seeking practical feedback in a short amount of time. We conceived the pilot study described in the current report to resemble a round robin study as closely as possible, but to be fully self-contained within NIST and to be completed in a ten-week summer research project. To do this, we took advantage of the growing number of NIST-owned, consumer-level three-dimensional (3D) printers being purchased to aid NIST staff in their research endeavors. In this study, a test part was built three times on seven different NIST-owned 3D printers. The sizes of several features of the test part were measured three times by the same person. Variations in the sizes of the features were analyzed focusing on between-printer, within-printer, and between-measurement effects. The experimental methods and results are detailed here because they provide important insight and lessons that can apply to full-scale AM round robin studies.

2. Experimental Methods

A growing number of NIST staff members use consumer-grade polymer extrusion machines to aid in their research. This study examined the variability of a test part produced by several of these machines.

2.1 Test Part

The part designed for this study was small and simple. An octagonal base encompassed five features: two protruding features (one cylinder and one square prism), two negative (indented) features (one square and one circle), and one center through hole. Figure 1 shows a solid model of the test part. The octagonal base was 40 mm across. The circular features each had a diameter of 10 mm, and square features each had a side length of 10 mm. The octagonal shape was chosen to prevent warping, which is more pronounced on parts whose shapes have sharp angles. The part was designed to allow easy measurement with low measurement uncertainty. A quick build was desired because NIST staff were volunteering their time and machines to the study and minimal time and material were thought to be more palatable. This test part could be completed in approximately 20 minutes.

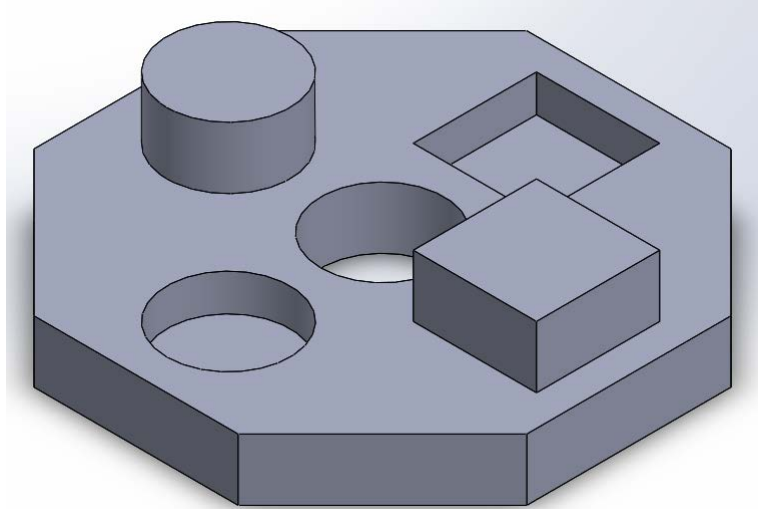

Figure 1. Solid model of the test part designed and built as part of NIST 3D printer round robin.

2.2 Manufacturing Plan

The manufacturing plan is the detailed procedure each participant would follow when performing builds. The study coordinator stressed the importance of abiding by the plan to minimize the influence of many of the variables that might impact builds.

The manufacturing plan was developed by the study coordinator to address each step and variable encountered in producing a part on the 3D printer and was demonstrated to create the test part successfully on one system before the plan was distributed to the study participants. The plan defined the required material—Polylactide Resin (PLA) was selected with the requirement that the material be sourced from the machine manufacturer. If a user did not have the required material, it was supplied to the user by the study coordinator. The manufacturing plan described the physical setup of the printer to be conducted prior to starting each build. This setup addressed the build platform surface preparation (a fresh layer of blue painters tape) and a detailed procedure for leveling the platform. The build platform was not heated for these tests. A maintenance protocol to clean the printer nozzle prior to each build was defined. Part location and orientation were defined as the center of the platform with the flat bottom face of the test part base flat on the build platform. The machine settings input into the system's control software were defined in the manufacturing plan and are listed in Table 1. Finally, the plan provided instructions on how to remove the part from the build platform, and how to clean the part and machine.

In addition to simply following the manufacturing plan, the participants were asked to fill out a template to document the steps taken according to the manufacturing plan. This document acts as a checklist, reminding users of the steps they must follow in setting up the build and instructing them to record the values they input. It also provided space to record comments regarding the state of the machine, unexpected errors that required action, or problems with the manufacturing plan. The process control document was returned to the study coordinator along with the built test parts.

Table 1: Machine settings described in the manufacturing plan.

Setting	Value
Nozzle Temperature	230 °C
Layer Height	0.2 mm
Object Infill	10 %
Feedrate (while extruding)	80 mm/s
Number of Shells	2
Raft	Off
Supports	Off/None

2.3 Participants and Number of Samples

The original study parameters called for several NIST staff each to build three test parts in separate builds on their respective machines. Seven NIST staff members volunteered to participate. All of the printers used in the study were from the same machine manufacturer, but one system used a different (older) model than the others. Since the manufacturing plan could be followed using either model, this was deemed to be within the scope of the study. Unfortunately, one participant was only able to deliver test parts made in acrylonitrile butadiene styrene (ABS), and could not produce the parts in PLA. Since it was unclear if the material type would influence the results, this participant's samples were not included in the analysis. Fortunately one participant was able to deliver an additional set of three test parts from a second machine in her possession. One participant was actually able to build seven test parts. Another participant was able to produce one test part, but found that the builds were failing (for an unknown reason) after that. While these circumstances deviated from the original study parameters, the data analysis accurately accounts for them. In total, 23 test parts produced by six volunteers from seven systems were included in the study.

2.4 Measurement

The as-built geometry of the test part was chosen as the characteristic to define the variability of builds from various laboratories. Dimensional measurements were made by one person with one set of handheld digital calipers. The standard uncertainty in each measurement was 0.02 mm. Nineteen measurements were made of various features of the test part (see Figure 2). Each measurement on each part was taken three times. The caliper was zeroed before each measurement to reduce instrument variability.

3. Results and Data Analysis

To quantify variation in the test parts, the measurement data was grouped by feature, and then separated by printer into seven sections. Using the program R [3] – a programming environment for statistical data analysis and graphics – an analysis of variance was performed by fitting a mixed effects model [4] to each feature. The mixed effects model expressed the length of a feature as a sum of contributions from a fixed effect and from multiple random effects. The fixed effect is the size of the feature. The model decomposed variability into contributions from the random effects: differences between printers, differences between builds within the same

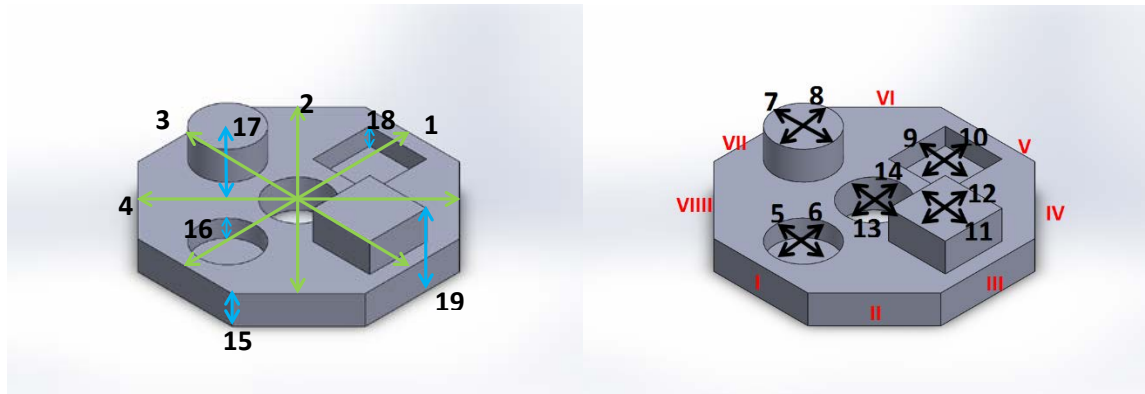

Figure 2. The sizes of nineteen features were measured on each test part.

printer, and differences of replicated measurements of the same build. Each of these contributions was quantified by a standard deviation – the larger the standard deviation, the more important the corresponding source of variability.

The results of the analysis of variance show that between-printer variability was larger than both within-printer and measurement variabilities for seventeen of the nineteen features. The only exceptions were features 8 and 12 where the measurement variability was largest. Figure 3 illustrates these results. For features 8 and 12, the measurement protocol did not specify a consistent measurement position along the height of the cylinder and prism for each replicate measurement. This indicates that features may have large straightness or parallelism deviation in the z-direction. Those exceptions aside, printer variability was not only larger, but often much larger (from 4 to 10 times larger) than the variability attributable to the other sources.

A box and whisker plot further demonstrates the dominance of between-printer variability on the overall variability of the data. The box and whisker plot for feature 4 is shown in Figure 4. This plot is typical of most box and whisker plots from this study summarizing each feature. In this plot, each set of box and whiskers represents the measured values of one feature in builds from one printer. The dark horizontal bar depicts the median of the measurements, the height of the box encompasses the middle 50 % of the data, and the bottom and top whiskers depict the minimum and maximum measurement values respectively. It is easy to see that the boxes are rather short compared to the overall range of the data, and that there is not much overlap between the boxes. This leads to the conclusion that the variability is primarily a result of between-printer effects.

4. Discussion

One of the primary goals of this study was to understand how to improve AM round robin studies. Therefore it is important to look beyond the study results and include lessons learned in the study procedures.

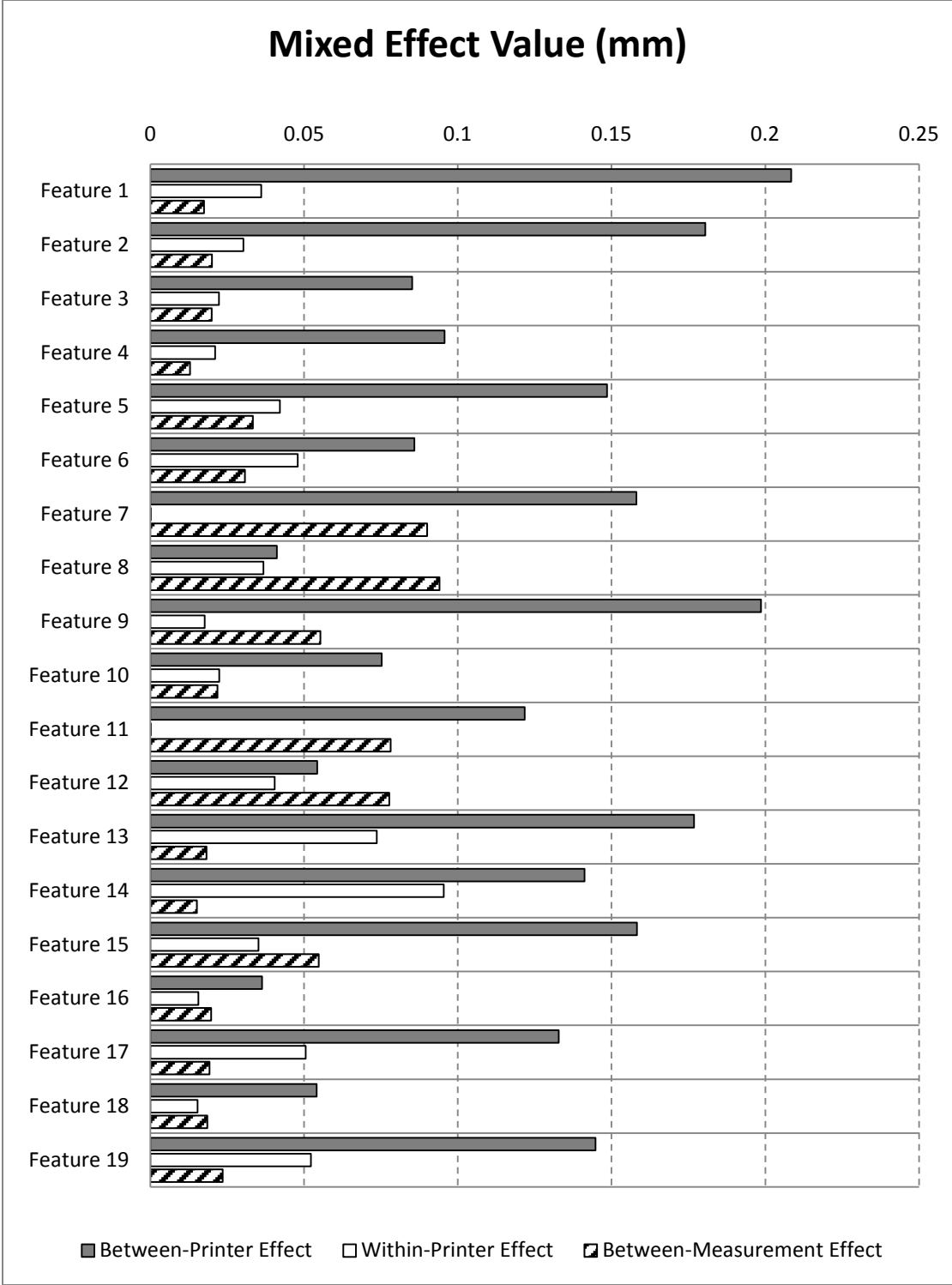

Figure 3. Plot of variability effects as determined by a mixed effects model.

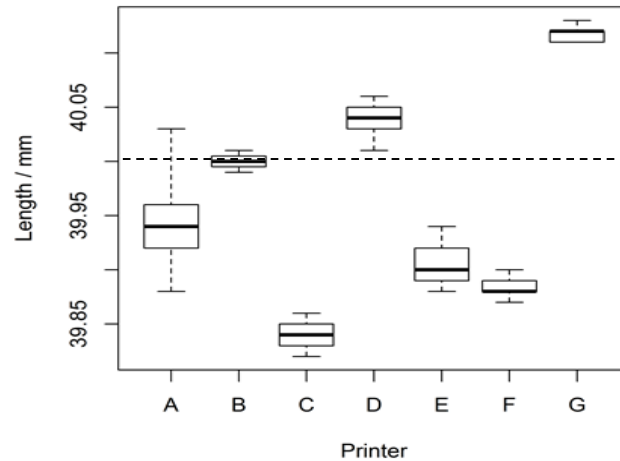

Figure 4. Box and whisker plot summarizing variation observed in measurement of the size of feature 4. Note that printer A produced 7 test parts, printer B produced 1 test part, and the others each produced 3 test parts. The horizontal dashed line is the designed length.

The template filled out by each participant with information about each build was more important than originally thought and should be expanded. The original intent was to promote consistency and document that each participant accurately followed the manufacturing plan. The template consisted of several check boxes to indicate that the participant performed key steps in the manufacturing plan, along with a table where the participants could enter identifying information (name, machine, software version, etc.), values input into the machine software, and observations during the build. When the results demonstrated relatively large variability, a better template could have been more helpful in interpreting the results. More information from the participants—the pedigree data associated with the machine and build—could have revealed where key differences existed and allowed for a more specific or detailed analysis of variance. For example, if the template requested the age of each system, the analysis of variance could have included this as one of the covariates and investigated its relative contribution to the overall variability. This template would be more important with more complex systems (e.g., metal-based AM systems) with more input variables.

A clear understanding among all participants about the requirements of the study and their respective capabilities would have helped avoid a waste of resources. For example, a participant in this study prepared test parts in ABS because he could not produce them in PLA. Had the participant known that this was a strict requirement, he would have known he could not participate in the study and would have avoided using his time and material. Again, the loss here is minor, but could be considerably more costly in larger studies with more expensive systems and materials. This type of confusion may occur more often with more complex systems where users have different levels of access to the software based on the license packages purchased by individual users.

Gauging participants' experience, capabilities, and access to relevant resources at the beginning of the study may be valuable. A few of the participants in this study were very experienced with 3D printing, while a couple were novices. It is assumed that all participants

accurately followed the procedures in the manufacturing plan, but it is possible that lesser experienced users unknowingly made mistakes. It may be possible in future studies to provide more oversight to less experienced users. This is mutually beneficial because the new users gain experience and insight while the oversight may help eliminate this potential source of variability. On the other hand, more experienced users may have modified their system, have better maintenance practices, or know “tricks of the trade” that others do not, allowing them to produce more accurate or consistent parts. If these factors are not addressed in the manufacturing plan or captured in the template, they may not be adopted by other participants in the study and remain invisible to the analysis. It may be beneficial to get more experienced users involved in planning the study to help improve the manufacturing plan and template.

The manufacturing plan may need to contain fewer specific values and more detailed procedures. It was thought that requiring each participant to use the same values would result in lower variability, but that may not have been the case. A hypothetical example can be seen in the nozzle temperature setting used in this study. Each participant used a nozzle temperature setting of 230 °C, as prescribed in the manufacturing plan. That temperature setting worked well in the one laboratory where the manufacturing plan was developed. However, temperature and humidity control in these laboratories were (understandably) coarse. It may be that if each printer used a slightly different nozzle temperature, one more suitable of the individual system and laboratory, more consistent parts would have resulted. One way to accomplish this while maintaining some consistency would be for the manufacturing plan to provide a detailed procedure for each participant to follow to determine the proper temperature for that system (the resulting temperature would be documented in the template). This concept demonstrates the need for machine performance testing and standardized calibration or compensation methods.

5. Conclusions and Future Work

The major takeaway from the results of this study is that between-printer variability plays a larger role than within-printer variability in the uncertainty of part attributes. This happened despite best efforts to ensure that participants used the same procedures and machine settings. This leads to the conclusion that there are sources of uncertainty still to be characterized that cause differences between nominally identical printers. One can speculate on the potential causes of this variability, e.g., differences in age of machines, maintenance or calibration history, etc., that were not adequately controlled by the manufacturing plans. However, one of the weaknesses of round robin studies is that it is often difficult to pinpoint a specific source of variability, especially when inadequate pedigree data is collected along with the test pieces. Since the round robin was intended to be very simple in design, it was impossible to gauge the effects of possibly influential factors.

Because AM is a relatively young technology and part variability tends to be large, it may be more important to examine the causes of variability. If so, then it should best be done in a suitably designed experiment where potential, likely sources of variability are varied deliberately and systematically. With a careful, well-thought-out design, it is possible to conduct such a study including multiple participants. In fact, results from this study and other AM round robin studies that NIST has been involved in show that between-participant variability is relatively

high, indicating that including multiple participants is an important component to the study. Future AM interlaboratory studies at NIST will follow this “collaborative experiment” approach.

Additionally, the need for round robin studies to characterize AM variability will certainly remain. Users can benefit from these early experiences and lessons learned. Toward this end, a new work item in ASTM Committee F42 on Additive Manufacturing Technologies [5] has been established for a “New Guide for Conducting Round Robin Studies for AM.” A standardized approach to round robin studies will encourage broader participation in future studies, clarify requirements for material and process specifications, and simplify interpretation of results.

Acknowledgements

The authors would like to thank the NIST participants of the study who took the time to help a summer intern with their time and resources. Without their help, this round robin would not have been possible. Matthew Staymates, Lourdes Bobbio, Stacy Bruss, Chad Boutin, Mark Esser, John Hettenhouser, Zeeshan Ahmed, Alec Jamgochian, Alden Dima, Sean McGivern, and Ryan Shorts all provided valuable contributions to this study.

References

- [1] Measurement Science Roadmap for Metal-Based Additive Manufacturing, 2013, http://events.energetics.com/NIST-AdditiveMfgWorkshop/pdfs/NISTAdd_Mfg_Report_FINAL.pdf (last accessed August 25, 2015).
- [2] Kelly, S., 2014, “Development of Mechanical Property Data for Laser Powder Bed Fusion Additive Manufacturing of Nickel Alloy 625,” http://ewi.org/eto/wp-content/uploads/2015/04/70NANB12H264_Final_Tech_Report_EWI_53776GTH_Distribution_Vol_1.pdf (last accessed August 25, 2015).
- [3] R Core Team, “R: A Language and Environment for Statistical Computing”, R Foundation for Statistical Computing, Vienna, Austria: www.R-project.org.
- [4] Pinheiro, J. C. and Bates, D. M., 2000, *Mixed-Effects Models in S and S-Plus*, Springer-Verlag, New York, NY.
- [5] <http://www.astm.org/COMMITTEE/F42.htm> (last accessed August 25, 2015).