

**NIST Technical Note 1842**

**Structural Design for Fire:  
A Survey of Building Codes and Standards**

Dat Duthinh



National Institute of Standards and Technology

**United States Department of Commerce**



# **NIST Technical Note 1842**

## **Structural Design for Fire: A Survey of Building Codes and Standards**

Dat Duthinh

August 2014



*U.S. Department of Commerce*

*Penny S. Pritzker, Secretary*

National Institute of Standards and Technology

*Willie E. May, Acting Director*



# Abstract

This document is a critical assessment of building codes and standards pertaining to structural design for fire from the United States, Canada, European Union members, Japan, New Zealand and Australia. These countries were selected because of their vigorous research activities on this topic, and the relevance of their engineering practice to that in the US. In the US, there is a dynamic interplay between various consensus-based code writing bodies (such as the International Building Code), and professional associations (such as the Society of Fire Protection Engineers, the National Fire Protection Association, the American Society for Testing and Materials, the American Society of Civil Engineers, the American Institute for Steel Construction, the American Concrete Institute International, and the Precast/prestressed Concrete Institute), which can produce authoritative and influential guidance documents. It has been necessary to study not just the codes and standards, but also the specifications and guides where applicable. The review presents both prescriptive and performance-based standards, but puts more emphasis on the latter, and topics that are the subject of current research or in need of updating. The structural materials covered are steel, concrete and composites of steel and concrete. The assessment identifies gaps in U.S. codes and standards for the design of structures for fire.

**Keywords:** building codes; building standards; concrete; fire; steel; steel-concrete composite; structural engineering.

## **Disclaimer**

The policy of the NIST is to use the International System of Units (SI) in its technical communications. In this document, however, building codes and standards in the US are referenced in both customary (as is the practice in US construction industry) and SI units.

## CONTENTS

Abstract.....	v
List of figures.....	x
List of tables.....	xi
<b>CHAPTER 1 INTRODUCTION AND SCOPE.....</b>	<b>1</b>
<b>CHAPTER 2 STRUCTURAL DESIGN FOR FIRE: PRESCRIPTIVE AND PERFORMANCE STANDARDS.....</b>	<b>2</b>
2.1 Prescriptive design.....	2
2.1.1 USA: The International Building Code IBC 2012.....	3
2.1.2 Eurocode.....	5
2.1.3 New Zealand Building Regulations 1992, reprinted 10 April 2012.....	6
2.1.4 Australian Building Codes Board, National Construction Code, 2012.....	8
2.1.5 2010 National Building Code of Canada (NBCC).....	9
2.2 Performance-based structural fire design.....	9
2.2.1 USA: Society for Fire Protection Engineering (SFPE).....	10
2.2.2 USA: International Code Council Performance Code for Buildings and Facilities, 2012.....	11
2.2.3 USA: American Institute of Steel Construction Steel (2011) AISC Construction Manual.....	11
2.2.4 Eurocode 1 (2010): Actions on Structures Part 1-2: General Actions - Actions on Structures Exposed to Fire.....	12
2.2.5 New Zealand Building Regulations 1992, reprinted 10 April 2012.....	14
2.2.6 The Building Code of Australia, National Construction Code Series 2012.....	15
2.2.7 2010 National Building Code of Canada (NBCC).....	16
2.2.8 Canadian Standards Association CSA S16-09 Limit States Design of Steel Structures.....	16
2.2.9 The Building Standard Law of Japan.....	17
2.3 Load combinations involving fire.....	17
2.3.1 AISC 2011 14th Ed. Appendix 4 Structural Design for Fire Conditions.....	17
2.3.2 Eurocode.....	18
2.3.3 Australia / New Zealand Standard AS/NZS 1170.0.2002.....	18
2.3.4 2010 National Building Code of Canada (NBCC).....	18
2.3.5 The Building Standard Law of Japan August 2011.....	19
2.4 Critical assessment.....	19
References.....	19
<b>CHAPTER 3 FIRE EXPOSURE.....</b>	<b>22</b>
3.1 Standard fires.....	22
3.1.1 ASTM E119 (2012) Standard Test Methods for Fire Tests of Building Construction and Materials.....	22
3.1.2 ASTM E1529-13 Standard Test Methods for Determining Effects of Large Hydrocarbon Pool Fires on Structural Members and Assemblies.....	23
3.1.3 Other standard time-temperature curves.....	24
3.1.4 Time equivalence.....	25
3.2 EUROCODE parametric fire curves.....	27
3.3 Design fires and fire scenarios.....	29
3.3.1 SFPE S.01 2011 SFPE Engineering standard on calculating fire exposures to structures.....	29
3.3.2 NFPA 5000 Building Construction and Safety Code Handbook (2003).....	30
3.3.3 NFPA 557 Standard Determination of Fire Loads for Use in Structural Fire Protection Design (2012).....	31

3.3.4	AISC 2011 14th Ed. Appendix 4 Structural Design for Fire Conditions.....	32
3.3.5	ISO/TS 16733 (2006) Fire Safety Engineering- Selection of design fire scenarios and design fires.....	33
3.3.6	Eurocode.....	33
3.3.7	New Zealand Building Regulations 1992, reprinted 10 April 2012.....	34
3.3.8	AS 1530.4–2005 Methods for fire tests on building materials, components and structures....	37
3.3.9	The Building Standard Law of Japan August 2011.....	37
3.4	Localized fire exposure.....	39
3.4.1	SFPE S.01 2011 Engineering standard on calculating fire exposures to structures.....	39
3.4.2	Localized fires from Eurocode Annex C DIN EN 1991 1-2:2010-12.....	40
3.5	Critical assessment.....	41
	References.....	42
<b>CHAPTER 4 STEEL STRUCTURES.....</b>		<b>45</b>
4.1	Prescriptive methods.....	45
4.1.1	USA: ASCE/SEI/SFPE 29-05 Standard Calculation Methods for Structural Fire Protection..	45
4.1.2	USA: The International Building Code IBC 2012, Chapter 7: Fire and Smoke Protection Features.....	46
4.1.3	National Building Code of Canada (NBCC) 2010 vol. 2 Appendix D Fire-performance ratings	47
4.2	Performance-based methods.....	47
4.2.1	Methods for predicting temperatures in fire-exposed structures.....	47
4.2.2	Eurocode 3: Design of steel structures- Par 1-2: General rules- structural fire design.....	49
4.2.3	USA: AISC 2011 14th Ed. Appendix 4 Structural Design for Fire Conditions.....	55
4.2.4	Canadian Standards Association CSA S16-09 Limit States Design of Steel Structures.....	60
4.2.5	New Zealand and Australia.....	64
4.2.6	The Building Standard Law of Japan August 2011 – Steel.....	65
4.3	Critical assessment.....	68
	References.....	71
	Appendix: 2% yield strain and 0.2% proof strain.....	73
<b>CHAPTER 5 REINFORCED CONCRETE STRUCTURES.....</b>		<b>74</b>
5.1	Calculation methods for concrete in USA.....	74
5.1.1	ASCE/SEI/SPFE 29-05 Standard Calculation Methods for Structural Fire Protection.....	74
5.1.2	ACI 216.1-07/ TMS 0216-07.....	75
5.1.3	ACI 216R-89 Guide for Determining the Fire Endurance of Concrete Elements.....	78
5.1.4	USA: The International Building Code IBC 2012.....	81
5.1.5	The Society of Fire Protection Engineers.....	81
5.1.6	Spalling prevention measures in USA.....	84
5.2	Calculation methods for concrete in Europe.....	84
5.2.1	Simple one-dimensional thermal calculation for concrete (Wickstrom, 2008).....	86
5.2.2	High-strength concrete .....	86
5.2.3	Spalling.....	87
5.3	Calculation methods for concrete used in New Zealand and Australia.....	88
5.4	2010 National Building Code of Canada, Division B, Appendix D, Fire performance ratings...	88
5.5	The Building Standard Law of Japan, August 2011.....	89
5.6	Critical assessment.....	91
	References.....	91

<b>CHAPTER 6 COMPOSITE STRUCTURES.....</b>	<b>93</b>
6.1 AISC 2011 14th ed. Appendix 4 Structural design for fire conditions - composite floor members.....	93
6.2 ASCE /SEI/SFPE 29-05 Standard calculation methods for structural fire protection – concrete-filled hollow steel tubes (Section 5.2.3).....	93
6.3 National Building Code of Canada 2010.....	94
6.4 The Building Standard Law of Japan, Aug. 2011.....	95
6.5 EUROCODE 4: EN 1994-1-2, Aug. 2005 - Design of composite steel and concrete structures – Part 1-2: general rules - structural fire design.....	95
6.6 Composite members in New Zealand (NZS 3404) and Australia (AS 4100).....	97
6.7 Critical assessment.....	98
References.....	98
<b>CHAPTER 7 PRESTRESSED CONCRETE STRUCTURES.....</b>	<b>101</b>
7.1 PCI 3rd ed. 2011: Design for fire resistance of precast/prestressed concrete.....	101
7.2 International Building Code 2012.....	102
7.3 ASCE/SEI/SFPE 29-05.....	102
7.4 EUROCODE 2-1-2 Design of concrete structures.....	103
7.5 New Zealand and Australia.....	103
7.6 2010 National Building Code of Canada, Division B, Appendix D, Fire performance ratings..	103
7.7 The Building Standard Law of Japan, August 2011.....	104
7.8 Critical assessment.....	104
References.....	104
<b>CHAPTER 8 RECOMMENDATIONS.....</b>	<b>106</b>
8.1 Develop slab membrane tension provisions in US building codes for steel beam-concrete slab composites in fire.....	106
8.2 Develop US code provisions for spalling of concrete, especially high-strength concrete...	106
8.3 Develop US performance code provisions for steel connections in fire.....	106
8.4 Improve steel stress-strain relationships at elevated temperatures in future US performance building code.....	107
8.5 Update provisions for plate buckling strength at elevated temperatures, and asses need for revision of other design equations due to change in shape of steel stress-strain curve at elevated temperatures.....	107
8.6 Investigate effects of temperature gradient on simple design equations of steel and composite structures.....	107
8.7 Expand scope of US code provisions for concrete-filled tube (CFT) columns.....	108
8.8 In US performance-based codes, develop methodology for analyzing parts of structure most affected by fire.....	108
8.9 Continue development of design fires and fire models.....	109
References.....	110

## List of Figures

<b>Chapter 2 Structural design for fire: prescriptive and performance standards</b>	
Figure 2.1 Design procedure according to the Eurocode prescriptive codes.....	5
Figure 2.2 Hierarchical Relationship for Performance-Based Design (Buchanan 2001).....	9
Figure 2.3 Design procedure for the Eurocode performance-based codes.....	14
<b>Chapter 3 Fire Exposure</b>	
Figure 3.1 ASTM E119 standard time-temperature curves.....	24
Figure 3.2 Standard time-temperature curve used in furnace fire tests, cooling curves, curves representing the temperatures in a typical occupancy test, and equivalent areas; adapted from Ingberg (1928).....	25
<b>Chapter 4 Steel Structures</b>	
Figure 4.1 Reduction factors for the stress-strain relationship of carbon steel at elevated temperatures.....	50
Figure 4.2 Comparison of compression and flexural strengths at 500 °C (932 °F) – Takagi and Deierlein (2007).....	57
Figure 4.3 Comparison of compression and flexural strengths at 500°C (932°F).....	62
Figure 4.4 Variation of mechanical properties of steel with temperature.....	64
Figure 4.5: Eurocode (CEN 2001) stress-strain curves of steel at elevated temperatures from 100°C to 900°C .....	73
<b>Chapter 5 Reinforced Concrete Structures</b>	
Figure 5.1 Strength of various types of reinforcement and concrete at high temperatures (ACI 216.1-07).....	76
Figure 5.2 Temperature distribution in a normal-weight concrete rectangular unit.....	77
Figure 5.3 Moment diagram for one half of a continuous three-span beam before and during fire exposure.....	79
Figure 5.4 Nomographs relating thrust parameter, strain parameter, and ratio of cross-sectional area to heated perimeter.....	80
Figure 5.5 Redistributed applied bending moment diagram.....	82
Figure 5.6 Coefficient $k_{c,\vartheta}$ for decrease of characteristic strength $f_{ck}$ of normal weight concrete with siliceous (1) or calcareous (2) aggregates.....	85
Figure 5.7 High-strength concrete strength reduction factor $f_{c,\vartheta}/f_{ck}$ at high temperatures for Class 1 (C55/67 and C60/75), Class 2 (C70/85 and C80/95) and Class 3 (C90/105) concrete. Class ( $f_{ck,cylinder}/f_{ck,cube}$ ), $f_{ck}$ = characteristic strength.....	86

## List of Tables

<b>Chapter 2 Structural Design for Fire: Prescriptive and Performance Standards</b>	
Table 2.1 Prescriptive design documents from various countries.....	4
Table 2.2 Fire resistance rating requirements for building elements (hours).....	4
Table 2.3 Fire resistance rating (hours) requirements for exterior walls based on fire separation distance.....	4
Table 2.4 Acceptable Solutions, New Zealand Building Code.....	6
Table 2.5 Building classes (National Construction Code of Australia, 2012).....	8
Table 2.6 Building types (National Construction Code of Australia, 2012).....	8
Table 2.7 Performance design documents from various countries .....	10
Table 2.8 Heat flux between buildings.....	16
<b>Chapter 3 Fire Exposure</b>	
Table 3.1 Conditions of acceptance for beams and floor and roof assemblies.....	23
Table 3.2 Fire frequency.....	31
Table 3.3 Fraction $c$ of structurally significant fires in office/business occupancies.....	32
Table 3.4 Fire load density.....	32
Table 3.5 List of 10 fire design scenarios.....	34
Table 3.6 Pre-flashover design fire characteristics.....	35
Table 3.7 Design Fire Load Energy Density (FLED) for use in modeling fires in C/VM2.....	36
Table 3.8 Fire load density $q_f$ per unit floor area: excerpt from Notification 1433.....	37
Table 3.9 Heat release rate $q_b$ : excerpt from Notification 1433.....	38
Table 3.10 Local fire temperature rise coefficient: excerpt from Notification 1433.....	39
<b>Chapter 4 Steel Structures</b>	
Table 4.1 Stress-strain reduction factors in EC3.....	50
Table 4.2 High-temperature tensile data for structural steel.....	70
<b>Chapter 5 Reinforced Concrete Structures</b>	
Table 5.1 Fire resistance of concrete walls, floors and roofs.....	74
Table 5.2 Minimum cover for non-prestressed reinforcement in concrete beams.....	75
Table 5.3 Minimum concrete column dimension.....	75
Table 5.4 Excerpt from IBC Table 722.2.3 for an FRR of 3 h.....	81
Table 5.5 Location of thermal thrust line.....	83
Table 5.6 Minimum dimensions and cover thickness for RC members.....	89
<b>Chapter 6 Composite Structures</b>	
Table 6.1 Values of constant $a$ (ASCE).....	94
Table 6.2 Values of constant $a$ (NBCC).....	94
<b>Chapter 7 Prestressed Concrete Structures</b>	
Table 7.1 Restrained and unrestrained fire rating based on tests.....	102
Table 7.2 Minimum cover thickness - inches (mm).....	102
Table 7.3 Minimum cover for prestressed reinforcement in beams 40 in <sup>2</sup> (26 000 mm <sup>2</sup> ) or greater in area.....	103
Table 7.4 Minimum thickness of concrete cover over steel tendons in prestressed concrete beams.....	104

# **Structural Design for Fire: A Survey of Building Codes and Standards**

## **Chapter 1 Introduction and Scope**

This document is a critical assessment of building codes and standards pertaining to structural design for fire from the United States, Canada, European Union members, Japan, New Zealand and Australia. These countries were selected because of their vigorous research activities on this topic, and the relevance of their engineering practice to that in the US. In the US, there is a dynamic interplay between various consensus-based code writing bodies (such as the International Building Code), and professional associations (such as the Society of Fire Protection Engineers, the National Fire Protection Association, the American Society of Testing and Materials, the American Society of Civil Engineers, the American Institute for Steel Construction AISC, the American Concrete Institute International ACI, and the Precast/prestressed Concrete Institute), which can produce authoritative and influential guidance documents. It has been necessary to study not just the codes and standards, but also the specifications and guides where applicable. The review presents both prescriptive and performance-based standards, but puts more emphasis on the latter, and topics that are the subject of current research or in need of updating. The structural materials covered are steel, concrete and composites of steel and concrete. The assessment identifies gaps in U.S. codes and standards for the design of structures for fire.

The document is organized in eight chapters. Chapter 1 introduces the scope of the survey. Chapter 2 presents the concepts behind prescriptive and performance-based standards. Chapter 3 reviews methods used to model fires, including standard fires, as well as various fire scenarios and design fires. Chapters 4 to 7 review design and analysis methods for structures made of steel (Ch. 4), reinforced concrete (Ch. 5), steel-concrete composites (Ch. 6) and prestressed concrete (Ch. 7). Finally, Chapter 8 offers recommendations for future work that addresses the identified gaps in US building codes and standards.

# Chapter 2 Structural Design for Fire: Prescriptive and Performance Standards

There is general agreement that the goals of structural design against fire are to limit risks to the individual and society, to directly exposed or neighboring property, and to the environment. To meet these goals, fire protection requirements use the prescriptive format, e.g., they specify the permissible materials for buildings, the thickness of insulation, or the minimum acceptable spacing between buildings. This is the traditional approach that continues to this day. In the early 1970s, performance-based approaches were developed, following an evolution in the understanding of fire and building performance in fire. Performance-based methods allow the designers to account for the unique features and uses of buildings and promote a better understanding of how buildings perform in fire. Compared to prescriptive methods, performance-based approaches have a greater potential to promote innovation and cost savings, but require more expertise.

## 2.1 Prescriptive Design

Traditionally, building codes have specified prescriptive methods to improve fire safety in buildings. These methods use:

- fixed values, such as maximum travel distance, minimum fire resistance ratings and minimum features of required systems, such as detection, alarm, suppression and ventilation;
- Safety factors, typically historically based, used to account for uncertainties inherent in the data, and to achieve the desired excess capacity;
- Exposure to a standard fire, such as ASTM E119 (2012) or ISO 834 (2002). The standards that focus on fire exposure (time-temperature curves) and fire scenarios, such as NFPA 5000, are discussed in Chapter 3.

Most prescriptive codes include an equivalency clause that allows the use of performance-based methods to satisfy the intent of the code. Table 2.1 lists various codes and standards that follow a prescriptive format and are studied in the present document.

**Table 2.1 Prescriptive design documents from various countries**

Country	Title	Document type	Year
USA	The International Code Council International Building Code	Building code	2012
USA	ASCE/SEI/SFPE 29-05 Standard Calculation Methods for Structural Fire Protection <sup>1,3</sup>	Standard	2005
USA	ACI 216.1-07/ TMS 0216-07 Code requirements for determining fire resistance of concrete and masonry assemblies <sup>1</sup>	Standard	2007
USA	PCI 3 <sup>rd</sup> ed. Design for fire resistance of precast /prestressed concrete <sup>2</sup>	Standard	2011
Europe	Eurocode1- 1-2: Actions on structures exposed to fire	Building code	2010
New Zealand	NZS 3404: Part 1:1997 (with Oct. 2007 amendments, currently applicable in 2013) Steel Structures Standard <sup>3</sup>	Standard	1997, 2007
New Zealand	NZS 3101: Part 1: 2006 (with Aug. 2008 amendments) Concrete Structures <sup>1</sup>	Standard	2006, 2008
New Zealand	Building Regulations	Building code	1992 2012
Australia	AS 4100-1998 Steel Structures - Section 12 Fire <sup>3</sup>	Standard	1998
Australia	AS 3600 - 2009 Concrete structures <sup>1</sup>	Standard	2009
Australia	Building Code of Australia, Vol. 1, Part C, Fire Resistance	Building code	2012
Canada	CSA A23.3-04 Design of Concrete Structures <sup>4</sup>	Standard	2004
Canada	CAN/CSA-S16-09 Limit States Design of Steel Structures <sup>3</sup>	Standard	2009
Canada	National Building Code of Canada	Building code	2010
Japan	Building Standard Law	Building code	2000, 2011

<sup>1</sup> will be discussed further in Chapter 5

<sup>2</sup> will be discussed further in Chapter 6

<sup>3</sup> will be discussed further in Chapter 4

<sup>4</sup> fire is not mentioned. This standard will not be discussed further.

### **2.1.1 USA: The International Building Code IBC 2012**

The International Building Code is a comprehensive building code that establishes minimum regulations for building systems using prescriptive and performance-based provisions. The first edition, issued by the International Code council (ICC) in 2000, was the culmination of efforts to unify three building codes that were in effect in various parts of the US, namely the codes issued by the Building Officials and Code Administrators International (BOCA), the International Conference of Building Officials (ICBO), and the Southern Building Code Congress International (SBCCI). The IBC follows a three –year updating schedule.

Fire resistance rating is determined in compliance with the test procedures set forth in ASTM E119 (see Chapter 3) or UL 263. If alternative methods are used, the fire exposure and acceptance criteria

specified in ASTM E119 or UL 263 should be used (Sections 703.2 and 703.3 of IBC 2012). The test specimen is deemed acceptable if it can sustain the applied load during the fire resistance test without passage of flame or gases hot enough to ignite cotton waste for a period ( $t_{class}$ ) equal to that for which classification is desired. For walls or partitions, and *restrained* or *unrestrained* beams and floor and roof assemblies, transmission of heat should not raise the temperature on the unexposed surface more than 250°F (139°C) above its initial temperature. Chapter 6 of the IBC 2012, Types of Construction, specifies the fire resistance rating requirements (in hours) for various types of construction and occupancy (Table 2.2, adapted from Table 601 of IBC 2012), and for exterior walls based on fire separation distance (Table 2.3, adapted from Table 602 of IBC 2012). The fire separation distance is defined as the distance measured perpendicular to the building face and from it to 1) the closest interior lot line, 2) the centerline of a street, an alley, or a public way, or 3) an imaginary line between two buildings on the property.

**Table 2.2 Fire resistance rating requirements for building elements (hours)**

Building element	Type I		Type II		Type III		Type IV	Type V	
	A	B	A	B	A	B	HT	A	B
Primary structural frame	3	2	1	0	1	0	HT	1	0
Bearing walls									
Exterior	3	2	1	0	2	2	2	1	0
Interior	3	2	1	0	1	0	1/HT	1	0

Types I and II: construction made of non-combustible materials;

Type III: exterior walls of non-combustible materials, interior building elements of any material;

Type IV: exterior walls of non-combustible materials, interior building elements of solid or laminated wood;

Type V: construction material of any permitted type.

Occupancy A: Assembly (defined by IBC as gathering of people);

Occupancy B: Business (office, professional or service transactions, including storage of records);

HT: heavy timber.

**Table 2.3 Fire resistance rating (hours) requirements for exterior walls based on fire separation distance**

Fire separation distance X	Type of construction	Occupancy group H	Occupancy group F-1, M, S-1	Occupancy group A, B, E, F-2, R, S-2, U
X < 5 ft X < 1.5 m	All	3	2	1
5 ft ≤ X < 10 ft 1.5 m ≤ X < 3.0 m	IA Others	3 2	2 1	1 1
10 ft ≤ X < 30 ft 3.0 m ≤ X < 9.1 m	IA, IB IIB, VB Others	2 1 1	1 0 1	1 0 1
X ≥ 30 ft X ≥ 9.1 m	All	0	0	0

Occupancy F-1: Hazardous materials, explosives;  
 Occupancy F-2: Hazardous materials, combustible liquids or gases;  
 Occupancy M: Mercantile (shops);  
 Occupancy R: Residential (hotels, group homes);  
 Occupancy S-1: Moderate hazard storage (furniture);  
 Occupancy s-2: Low hazard storage (food, metals);  
 Occupancy U: Utility (barns).

The IBC references other standards, such as those of the American Society of Civil Engineers (ASCE), the American Concrete Institute International (ACI), The Masonry Society (TMS), the Precast/Prestressed Concrete Institute (PCI) and the American Institute of Steel Construction (AISC). Other prescriptive standards used in the US include ACI 216.1-07/ TMS 0216-07 Code requirements for determining fire resistance of concrete and masonry assemblies, and PCI 3<sup>rd</sup> ed. 2011 Design for fire resistance of precast/prestressed concrete. These prescriptive requirements will be covered in Chapters 5 and 7 respectively. ASCE/SEI/SPFE 29-05 Standard Calculation Methods for Structural Fire Protection show how to calculate the equivalent fire resistance, in terms of hours, of concrete, timber, masonry and steel members, that would be achieved under the standard ASTM E119 fire test. The standard does not provide any guidance about the structural performance of members or structures under fire.

### 2.1.2 Eurocode

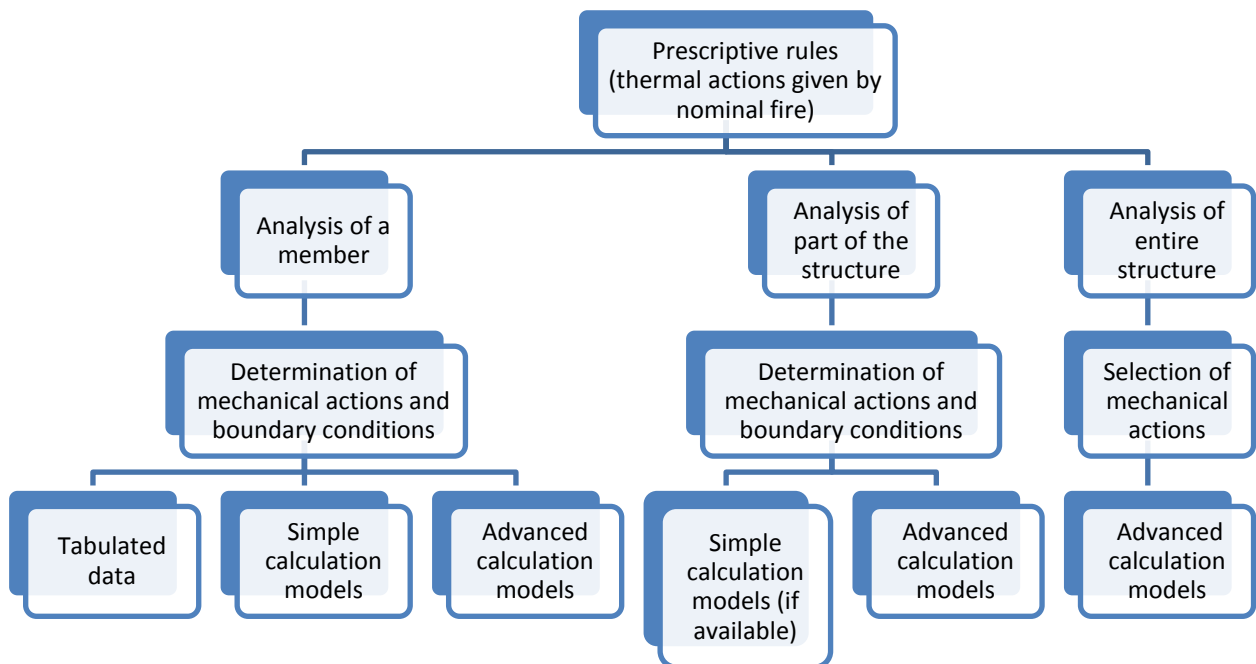

Figure 2.1 Design procedure according to the Eurocode prescriptive codes (EN 1991 1-2:2010-12, also in Phan et al. 2010 NIST TN 1681)

The Eurocode (EN 1991 1-2:2010-12) also includes prescriptive design recommendations, as shown in Fig. 2.1. The prescriptive approach uses nominal fires to generate thermal actions, and the rest of the analysis is similar to the performance-based approach. The standard temperature-time curve is described in Chapter 3. Figure 2.1 lays out clearly the different types of analysis expected in fire design, corresponding to the level of individual members, parts of the structure, and the entire structure. For each type of analysis, the loads, boundary conditions and analytical models available are listed. No equivalent framework exists in US codes (e.g., IBC 2012 or ASCE/SEI/SPFE 29-05), which tend to focus on individual members.

### 2.1.3 New Zealand Building Regulations 1992, reprinted 10 April 2012

There are seven Acceptable Solutions (AS), listed in Table 2.4, that are deemed to comply with the New Zealand Building Code. As stated at the beginning of this chapter, the New Zealand Building Code shares with all codes the same principles on structural design for fire, namely, to limit risks to the individual and society, to directly exposed or neighboring property, and to the environment. Following is some of the Commentary attached to the AS, which go into greater detail.

**Table 2.4 Acceptable Solutions (AS), New Zealand Building Code**

	Applies to	Risk group	Description
C/AS1	Single household units and small multi-unit dwellings	SH	Houses, townhouses and small multi-unit dwellings.
C/AS2	Non-institutional buildings for sleeping	SM	Permanent accommodation, e.g., apartments; transient accommodation, e.g., hotels, motels, hostels, backpackers; education accommodation.
C/AS3	Care or detention facilities	SI	Institutions, hospitals (excluding special facilities), residential care, resthomes, medical day treatment (using sedation), detention facilities (excluding prisons).
C/AS4	Public access and educational facilities	CA	Crowds, halls, recreation centers, public libraries (< 2.4 m storage height), cinemas, shops, personal services, schools, restaurants and cafes, early childhood centers.
C/AS5	Business, commercial and low-level storage buildings	WB	Offices, laboratories, workshops, manufacturing (excluding foamed plastics), factories, processing, cool stores (capable of < 3.0 m storage height) and other storage buildings capable of < 5.0 m storage height, light aircraft hangars.
C/AS6	High-level storage and other high-risk buildings	WS	Warehouses (capable of ≥ 5.0 m storage height), cool stores (capable of ≥ 3.0 m storage height), trading and bulk retail (≥ 3.0 m storage height).
C/AS7	Vehicle storage and parking buildings	VP	Vehicle parking – within a building or a separate building.

#### General principles

External walls and roofs must be constructed to avoid vertical and horizontal fire spread.

The necessary protection may be achieved by one or more of:

- a) Separation distance between buildings;
- b) Using building elements that have a fire resistance rating (FRR);
- c) Restricting the use of combustible surface finishes;
- d) Limiting the areas of external walls and roofs that are close to a title boundary and that do not have an FRR;
- e) Providing parapets, spandrels or aprons; and
- f) Protecting the building with an automatic fire sprinkler system.

### **Fire resistance ratings**

To prevent fire spread or structural collapse, the Acceptable Solutions require building elements to have FRRs. The level of FRR required depends on the risk group of the building. An FRR comprises three numbers, which give time values in minutes for structural adequacy, integrity and insulation:

a) Structural adequacy is usually provided by primary elements within a firecell. (A firecell is any space including a group of contiguous spaces on the same or different levels within a building, which is enclosed by any combination of fire separations, external walls, roofs, and floors.)

Primary elements include building elements which are part of the structure, and those providing support to other elements with an FRR within the same or adjacent firecells. Examples are: columns, beams, floors and walls (which may also be fire separations).

b) Integrity is usually provided by secondary elements. Examples are fire separations, which are internal partitions and floors. Primary elements forming an integral part of a fire separation are also rated for integrity.

c) Insulation applies to fire separations and is required where the transmission of heat through the element may endanger occupants on the other side or cause fire to spread to other firecells or adjacent buildings. For example, insulation is necessary for fire separation between sleeping spaces, or for protecting a safe path.

### **General requirements for FRRs**

When applying FRRs to building elements such as walls and columns, it is necessary to consider the face of the element that will be exposed to fire. For example, if the required FRR is different on each side of the separation, the higher of the required ratings applies to both sides of the separation. In the case of floors, it is only required to rate the floor on the underside, as it is unusual for fires to burn through a floor and spread downwards. Columns, beams and other structural framing elements must either have the same FRR as the element they are attached to, or be designed so that, if they do collapse during a fire, this would not cause the collapse of the fire rated element.

### **Stability of building elements having an FRR**

#### **Vertical stability**

For building elements required to have an FRR:

- a) Primary elements in a vertical orientation (e.g., walls and columns) shall be rated for structural adequacy under the design dead and live loads and any additional loads caused by the fire.
- b) Primary elements in a horizontal orientation (e.g., floors and beams) shall be supported by primary elements with at least an equivalent structural adequacy rating.

#### **Horizontal stability**

Building elements required to have an FRR shall:

- a) Be cantilevered from a structural base having an equal or greater FRR;

- b) Be supported within the firecell by other building elements having an equal or greater FRR;
- c) Be supported by primary elements outside the firecell.

Other prescriptive methods for structural fire design in New Zealand are found in **NZS 3404: Part 1:1997 (with Oct. 2007 amendments, currently applicable in 2013) Steel Structures** (see Chapter 4 of this report), and **NZS 3101: Part 1: 2006, (with amendments Aug. 2008) Concrete Structures Chapter 4: Design for fire resistance**. The latter document states the same principle as the New Zealand Building Regulations, namely, that a member shall be designed to have an FRR that meets or exceeds the required fire resistance for the criteria of structural adequacy, integrity and insulation. The criteria for integrity shall be considered to be satisfied if the member meets the criteria for both insulation and structural adequacy for that period, if applicable. This topic will be discussed further in Chapter 5 of this report.

#### 2.1.4 Australian Building Codes Board, National Construction Code, 2012

##### Vol. 1, Specification C1.1, Fire Resistance Construction

The Fire Resistance Level (FRL) for various building elements is specified for various building classes (Table 2.5) and types (Table 2.6). The FRL is given in minutes for structural adequacy/ integrity/ insulation. For example, a fire-resisting lift or stair shaft for an industrial building three-story high (class 8, type B) is required to have an FRL of 240/120/120.

**Table2.5 Building classes (National Construction Code of Australia 2012)**

1	Single houses or attached dwellings separated by a fire-resisting wall
2	Buildings with multiple separate dwellings
3	Hotels, schools, detention centers
4	Only dwelling in a building of Class 5, 6, 7, 8 or 9
5	Office buildings
6	Retail shops, professional service buildings
7	Car parks, wholesale shops or storage
8	Laboratories, industrial facilities
9	Buildings of a public nature
10	Non-habitable buildings

**Table2.6 Building types (National Construction Code of Australia 2012)**

Number of stories	Building classes 2, 3, 9	Building classes 5, 6, 7, 8
4 or more	A	A
3	A	B
2	B	C
1	C	C

Other Australian building standards that include prescription against fire include **Australian Standards AS 4100-1998 Steel Structures - Section 12 Fire** (see Chapter 4), and **Australian Standards AS 3600 - 2009 Concrete structures** (see Chapter 5).The latter is a prescriptive standard which specifies minimum dimensions and protection for a given fire rating. Standard calculation methods are used, but with material properties at ambient replaced by those at elevated temperatures.

### 2.1.5 2010 National Building Code of Canada (NBCC)

To meet the objectives of the National Building Code, designers may use prescriptive acceptable solutions. Fire resistance rating (FRR) are determined from tests or calculated on the basis of Appendix D of the NBCC (See Chapter 5). Supporting members shall have an FRR not less than that of the supported members. It is noteworthy that in **Canadian Standards Association CSA A23.3-04 Design of Concrete Structures**, fire is not mentioned, except compliance with applicable building code.

Discussion of the prescriptive methods in **The Building Standard Law of Japan (BSL-J) 2011 Fire Resistance Verification Method** is deferred to later chapters.

## 2.2 Performance-based structural fire design

In the codes and standards reviewed, there is general agreement that the performance goals of structural design against fire are to limit risks to the individual and society, to directly exposed or neighboring property, and to the environment. Satisfactory performance can be demonstrated by engineering analysis or qualification testing. To achieve these overall goals, many countries are currently developing performance-based standards that would allow designers flexibility in the use of new materials and technology, while possibly reducing cost. According to Buchanan (2001), performance-based design starts with the setting of general, high-level goals, and then gets more specific with the definition of functional objectives and performance requirements that guide the designers to meet these goals. At the design level, performance-based standards recommend acceptable solutions and approved calculation methods, but leave open the possibility of alternative designs, provided these can be proven to meet the performance goals (Fig. 2.2). Compliance with performance-based codes can be attained by using either prescriptive methods (sometimes called acceptable solutions or approved calculation methods), or performance-based design (PBD). Following is a review of various guides, codes and standards that follow a performance-based format (Table 2.7).

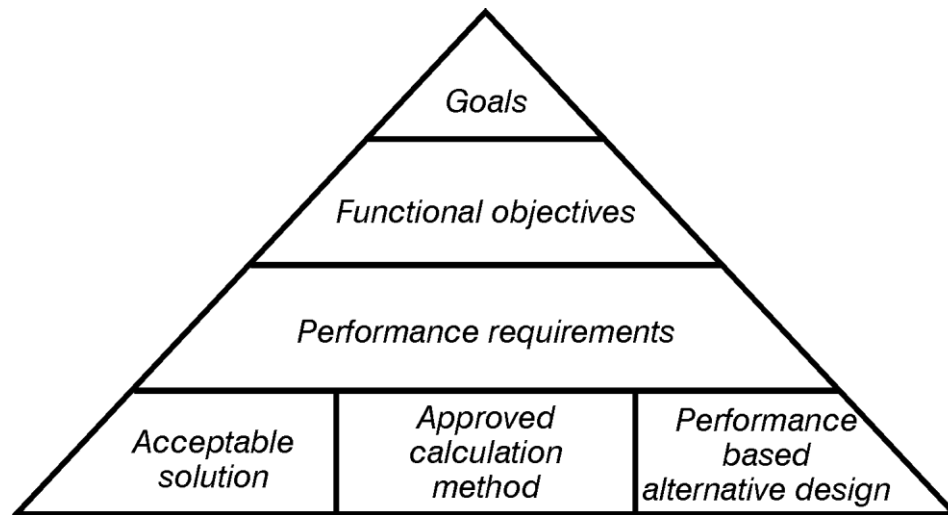

Figure 2.2 Hierarchical Relationship for Performance-Based Design  
(Buchanan 2001, Phan et al. 2010 NIST TN 1681)

**Table 2.7 Performance-based design documents from various countries**

Country	Title	Document type	Year
USA	SFPE Engineering Guide to Performance-Based Fire Protection	Guide	2007
USA	The International Code Council Performance Code for Buildings and Facilities	Building code	2012
USA	AISC Specifications Structural Design for Fire Conditions	Appendix to standards	2011
Europe	Eurocode1- 1-2: Actions on structures exposed to fire	Building code	2002
	Eurocode2- 1-2: Design of concrete structures - structural fire design <sup>1</sup>	Building code	2010
	Eurocode3- 1-2: Design of steel structures – structural fire design <sup>3</sup>	Building code	2005
	Eurocode4- 1-2: Design of composite steel and concrete structures - structural fire design <sup>2</sup>	Building code	2010
New Zealand	Building Regulations	Building code	1992, 2012
Australia	Building Code of Australia, Vol. 1, Part C, Fire Resistance	Building code	2012
Canada	National Building Code of Canada	Building code	2010
Canada	CAN/CSA-S16-09 Limit States Design of Steel Structures <sup>3</sup>	Standard	2009
Japan	Building Standard Law	Building code	2000, 2011

<sup>1</sup> will be discussed further in Chapter 5

<sup>2</sup> will be discussed further in Chapter 6

<sup>3</sup> will be discussed further in Chapter 4

### **2.2.1 USA: Society for Fire Protection Engineering (SFPE)**

#### **Engineering Guide to Performance-based Fire Protection, 2<sup>nd</sup> edition, 2007**

The SFPE Guide provides a general framework for performance-based design against fire. The first step is to define performance objectives, which are to mitigate the consequences of fire in buildings in terms of loss of life, financial cost on property, impact on operations and the environment, or maximum allowable conditions. These conditions include stability of structure, integrity of partitions, maximum temperature, extent of fire and smoke spread, and spread of combustion products.

The second step is to develop performance criteria, i.e., assign threshold values for temperature of materials and gases, toxic gas emission, thermal effects on structures, fire spread, fire barrier damage, structural integrity, damage to exposed properties and the environment, etc. These can be stated as either deterministic criteria, e.g., preventing flashover in the room of fire origin, or probabilistic criteria, e.g., reducing the probability of flashover below a threshold value.

The third step is to develop design fire scenarios, which are reviewed in Chapter 3. The fourth step is to develop trial designs for fire protection systems, construction features such as fire barriers, and operational procedures that meet the specified performance criteria for the design fire scenarios. The

fifth and final step is to evaluate the trial designs and select the final design based on effectiveness, reliability, availability and cost.

### **2.2.2 USA: The International Code Council Performance Code for Buildings and Facilities, 2012**

For fire impact management, the goal is to provide an acceptable level of fire safety performance in facilities in case of fire and to protect people during egress and rescue operations.

The functional objectives are to:

- Mitigate the spread of fire so that people not directly adjacent or involved in the ignition shall not suffer serious injury or death, and so that property losses are limited;
- Protect adjacent buildings and facilities from fire and smoke; and
- Allow firefighters to perform their function safely.

The performance requirements are (only fire spread and structural aspects are listed here):

- Design fire events shall realistically reflect the ignition, growth and spread potential of fires; For each design fire scenario considered, the analysis shall include the ignitability of the first item, the peak heat release rate of the first item ignited, the heat release rate and expected fire growth, and the overall fuel load, geometry and ventilation of the space and adjoining spaces;
- Design fires shall have appropriate factors of safety that reflect the uncertainties in their development and what level of damage is considered tolerable;
- Interior surface finishes shall resist the spread of fire and limit the generation of unacceptable levels of smoke, toxic gases and heat;
- Building materials shall limit fire growth and size to controllable levels;
- Facilities shall be arranged, constructed, and maintained so as to limit the impact of a fire on the structural integrity of the facility;
- Structural members and assemblies shall have a fire resistance appropriate to their function, the fire load, the predicted fire intensity and duration, the fire hazard, the height and use of the building, the proximity to other structures and any fire protection features;
- Exterior wall and roof assemblies shall restrict the spread of fire to and from adjacent buildings and from exterior fire sources; and shall resist the spread of fire by limiting their contribution to fire growth and development.

### **2.2.3 USA: American Institute of Steel Construction Steel (2011) “AISC Construction Manual, Appendix 4: Structural Design for Fire Conditions,” 14<sup>th</sup> Ed.**

The AISC lists the following **performance requirements**:

- The structure should maintain its load-bearing function under the design-basis fire.
- It should also satisfy displacement constraints to maintain fire barrier and compartmentalization requirements.
- Satisfactory performance can be demonstrated by engineering analysis or qualification testing.

As part of general structural integrity requirements, the structural system should be able to sustain local damage due the design basis fire and maintain a stable continuous load path to the foundation. The structural frame should have adequate strength and deformation capacity to withstand the structural

actions caused by the design basis fire, within prescribed limits of deformation. Furthermore, the connections should be designed to allow the connected members to develop their full strength .

To satisfy the performance requirements, two methods of engineering analysis are possible: a simple analysis that assumes the support and restraint conditions remain unchanged from normal temperatures is allowed for evaluating the performance of individual members during fire exposure. If member temperatures are below 200°C (400°F) material properties may be assumed unchanged from normal temperatures.

An advanced analysis of the effects of the design basis fire on the structure includes a thermal and a mechanical analysis. The mechanical analysis should account for the temperature dependence of material properties, the effects of thermal expansion, large deformations, and possible changes in boundary conditions and connection fixity. All relevant limit states, such as excessive deflections, connection fractures, overall and local buckling should be considered.

Satisfaction of performance requirements can also be met by qualification testing, which refers to prescriptive methods of determining fire resistance of components or assemblies through standard fire tests or approved equivalence calculation methods.

#### **2.2.4 Eurocode 1 (2010): “Actions on Structures Part 1-2: General Actions - Actions on Structures Exposed to Fire”**

According to the Eurocode, the goals of fire protection are to limit risks with respect to the individual and society, neighboring property, and the environment or directly exposed property, in the case of fire. Functional objectives for structures in the event of fire address:

- Load bearing resistance of the construction can be demonstrated for a specified period of time;
- Generation and spread of fire and smoke within the works are limited;
- Spread of fire to neighboring construction works is limited;
- Occupants can leave the building or can be rescued by other means; and
- Safety of rescue teams is taken into consideration.

Structural members and partitions must comply with the following performance criteria for a specified period of time under exposure to the design basis fire:

- Stability or mechanical resistance (criterion R): the structure should be able to maintain its load bearing function and provide a stable load path to the foundation;
- Integrity (criterion E): the fire should not create new openings in the structure, whose integrity limits the spread of fire and smoke within the burning building and to neighboring construction, and the provision of oxygen to the fire. This criterion sets limits on deformation and cracking to maintain fire barrier and compartmentalization requirements. The criteria of stability and integrity require that the structure maintains adequate strength and is able to sustain local damage within prescribed limits of deformation; and
- Insulation (criterion I): limits that can differ between countries are placed on the average temperature rise and maximum temperature on unexposed surfaces. For example, at the time

of maximum gas temperature, on surfaces not exposed to fire, the average temperature rise should be less than  $\Delta\theta_1 = 140$  K, and the maximum temperature rise at any point should be less than  $\Delta\theta_2 = 180$  K. For parametric fires, during the decay phase, the recommended values are  $\Delta\theta_1 = 200$  K and  $\Delta\theta_2 = 240$  K, unless specified otherwise by national codes.

These performance criteria are designed to allow the occupants to escape or be rescued, and to ensure the safety of emergency responders.

Three levels of analysis are possible: member analysis, analysis of part of the structure, or analysis of the entire structure. In member analysis, a structural member is considered isolated and unaffected by indirect fire actions, except those resulting from thermal gradients. Indirect actions are actions that result from constrained thermal expansion of the members themselves, differing thermal expansion within statically indeterminate members, thermal gradients within cross sections, or thermal expansion of adjacent members. While this type of analysis is directly comparable with furnace tests and can be used to calculate fire rating or insulation thickness, it cannot capture the response of a structural frame or the development of alternative load paths in the entire structure. At the next level, analysis of parts of the structure, indirect actions within the subassembly are considered, but time-dependent interactions with other parts of the structure are not. In other words, the boundary conditions of the subassembly are assumed unchanged from those at ambient temperature. At the highest level, global structural analysis, indirect actions are considered throughout the structure. Changes in boundary conditions and connection fixity, development of new load paths, such as by catenary or membrane action, etc., are accounted for. This type of analysis usually requires the capability to handle nonlinear geometric and material behavior. The flowchart in Fig. 2.3 describes the design procedure outlined in the Eurocode performance-based codes.

A structural fire analysis starts with selection of the relevant design fire scenarios, from which a set of design fires is determined. Next, temperature evolution within the structural members is calculated using a nominal time-temperature curve (prescriptive approach) or a parametric fire model or fire simulation (performance-based approach). The Eurocode performance-based codes (Fig. 2.3) use physically-based thermal actions. The designer has the choice of selecting fire models suitable for the physical characteristics of the situation such as compartment dimensions, openings, ventilation, calorific size and dimensions of the fuel load, and fire protection measures. Fire models are described further in Chapter 3. Depending on the project requirements, the fire performance analysis can be performed at three different levels: 1) individual members, 2) parts of the structure, or 3) the entire structure. The analysis includes all mechanical actions and appropriate boundary conditions and uses advanced calculation models, but member analyses may use alternative simple calculation models when available. Calculation of the mechanical behavior of the structure exposed to fire can be performed in the time domain (fire resistance  $\geq$  required fire resistance time, generally given in national fire regulations), the strength domain (design value of member resistance at time  $t \geq$  design value of relevant effects of actions at  $t$ ) or the temperature domain (design value of material temperature  $\leq$  design value of critical material temperature).

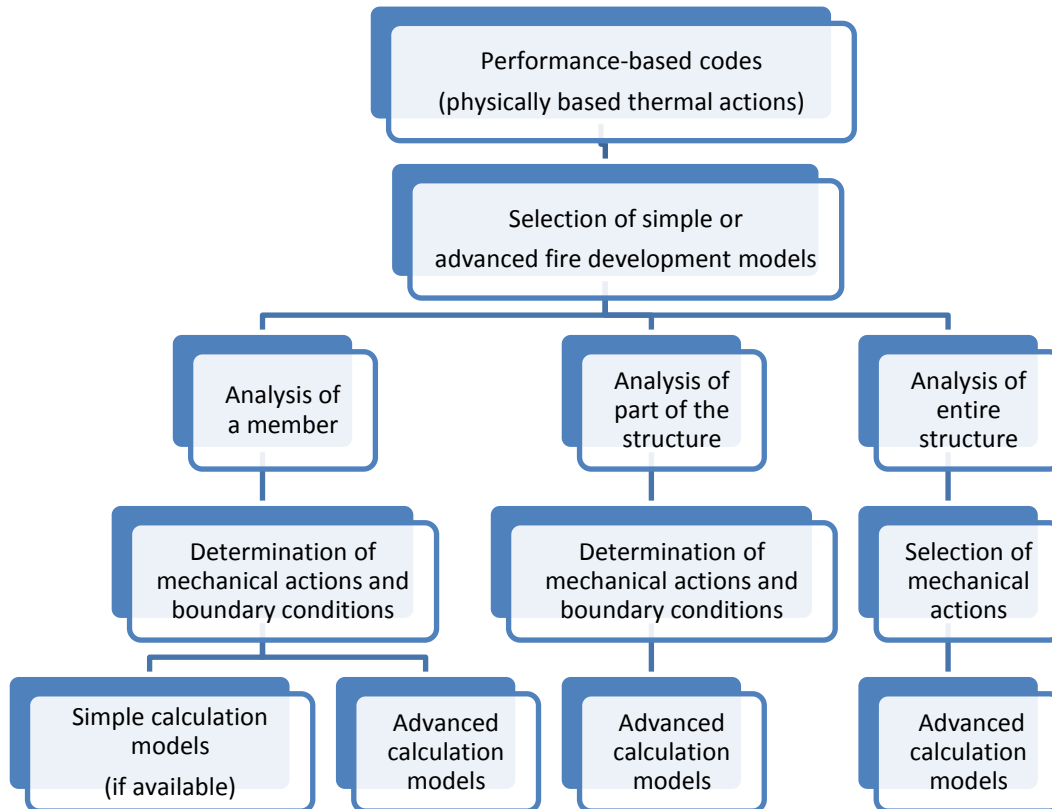

*Fig. 2.3 Design procedure for the Eurocode performance-based codes (EN 1991 1-2:2010-12, also in Phan et al.2010 NIST TN 1681)*

### 2.2.5 New Zealand Building Regulations 1992, reprinted 10 April 2012

The New Zealand Building Regulations follow a performance-based format. The **objectives** of the fire clauses (C1) are to:

1. Safeguard people from an unacceptable risk of injury or illness caused by fire;
2. Protect other property from damage caused by fire;
3. Facilitate firefighting and rescue operations.

Clause C3 deals with fire affecting areas beyond the fire source. The **functional requirements** are:

1. Low probability of injury or illness to people not in close proximity to fire;
2. Low probability of fire spread vertically or horizontally across relevant boundaries;
3. For buildings higher than 10 m where upper floors contain sleeping quarters or other property, design for low probability of external vertical fire spread to upper floors in the building.

In terms of **performance**, requirements for building materials are defined depending on how the occupants intend to use the relevant building area, and whether the building is protected by automatic sprinklers or not. Other performance standards include:

1. sleeping areas in buildings not protected by an automatic fire sprinkler system must be able to withstand a minimum critical radiant flux of  $4.5 \text{ kW/m}^2$  when exposed to ISO 9239-1:2010;

2. buildings must be designed and constructed so that fire does not spread more than 3.5 m vertically from the fire source over the external cladding of multi-level buildings;
3. buildings must be designed and constructed so that in the event of fire in the building, the received radiation at the relevant boundary of the property does not exceed  $30 \text{ kW/m}^2$ , and at a distance of 1 m beyond the relevant boundary of the property does not exceed  $16 \text{ kW/m}^2$ ;
4. buildings must be constructed from materials that, when subjected to a radiant flux of  $30 \text{ kW/m}^2$ , do not ignite for 30 minutes for importance levels 3 and 4, and 15 minutes for importance levels 1 and 2. There are five building importance levels (defined in Clause A3):
  - level 1: low risk to human life, such as minor storage facilities;
  - level 2: normal risk to human life (all buildings not listed in the other levels);
  - level 3: higher level of risk to occupants, such as schools or buildings where more than 300 congregate in one area;
  - level 4: buildings essential to post-disaster recovery or associated with hazardous materials;
  - level 5: buildings whose failure pose catastrophic risk to a large area ( $100 \text{ km}^2$ ) or a large number of people (100 000).
5. buildings must be designed and constructed with regard to the likelihood and consequence of failure of any fire safety system intended to control fire spread.

The functional requirements for **structural stability** are (C6):

1. low probability of injury or illness to occupants;
2. low probability of injury or illness to emergency personnel;
3. low probability of direct or consequential damage to adjacent property.

Some of the **performance standards** for structural stability follow:

1. Structural systems must remain stable during and after fire to protect other property, taking into account: fire severity, automatic fire sprinkler system, any other active fire safety system, and the likelihood of failure of any fire safety system;
2. Structural systems must remain stable during and after fire to provide firefighters safe access to floors;
3. Collapse of structural elements with lesser fire resistance must not cause the collapse of elements that are required to have higher fire resistance.

The New Zealand Building Regulations do not offer any guidance about calculation methods, such as for individual structural members, parts of a structure, or the entire structure.

### **2.2.6 The Building Code of Australia, National Construction Code Series 2012, Vol. 1, Part C, Fire Resistance**

The Building Code of Australia follows a performance-based format and is similar to New Zealand's. There are differences in some of the numbers, e.g., the Australian requirements equivalent to New Zealand's performance requirements 3 and 4 read as follows:

CV1: To avoid the spread of fire between buildings in adjoining allotments, a building will not cause heat flux in excess of those shown in Table 2.8. Conversely, a building located at the distances listed in Table 2.6 must be capable of withstanding the heat flux without ignition (note: no duration is given).

**Table 2.8 Heat flux between buildings**

Location	Heat flux
On boundary	80 kW/m <sup>2</sup>
1 m from boundary	40
3 m from boundary	20
6 m from boundary	10

### **2.2.7 2010 National Building Code of Canada (NBCC)**

The National Building Code of Canada follows an objective-based format and applies at the time of construction and reconstruction while the National Fire Code applies to the operation and maintenance of the fire-related features of buildings in use.

The **objective** for fire (or structural) safety, according to the NBCC are to limit the probability that, as a result of the design or construction of the building, a person in or adjacent to the building will be exposed to an unacceptable risk of injury due to fire (or structural failure).

#### **Functional statements:**

The objectives of this Code are achieved by measures, such as those described in the acceptable solutions, that are intended to allow the building or its elements to perform the following functions:

- To limit the severity and effects of fire and explosions;
- To retard the effects of fire on areas beyond its point of origin;
- To retard failure or collapse due to the effects of fire;
- To support and withstand expected loads and forces;
- To limit or accommodate dimensional change;
- To limit movement under expected loads and forces;
- To limit the risk of injury to persons as a result of contact with hot surfaces or substances;
- To minimize the risk of release of hazardous substances;
- To limit the spread of hazardous substances beyond their point of release;
- To maintain appropriate air and surface temperatures;

### **2.2.8 Canadian Standards Association CSA S16-09 “Limit States Design of Steel Structures”**

#### **Annex K: Structural design for fire conditions**

The development (CISC Commentary 2010) of CSA S16-09 Annex K parallels that of AISC Appendix 4. In Canada until recently, the design of steel structures for fire conditions followed the standard design equations at normal temperature, but with material properties altered on account of elevated temperatures. Takagi and Deierlein (2009) showed that this approach was unconservative and their work was instrumental in bringing about Annex K as part of the 2009 edition of CSA S16. The new approach is similar to that in AISC and agrees well with Eurocode methods. The structural design equations for fire apply for steel temperatures greater than 200°C and are consistent in form with (albeit more complicated than) their counterparts for ambient temperature. This will be discussed further in Chapter 5.

### 2.2.9 The Building Standard Law of Japan (BSL-J) 2011

The **performance standard** states that, when principal building parts are heated during a normal fire, the parts must not deform, melt, crack or undergo any other damage detrimental to structural strength. The **performance requirements** are: (1) Principal building parts must withstand the heat of a fire that could be expected to occur inside the building until the end of the fire; (2) External walls must withstand the heat of a normal fire occurring in the area surrounding the building until the end of the fire.

Since 2000 (Notification 1433 was issued in May 2000 and included in BSL-J 2004 and 2011), there are three alternative routes to design for structural safety against fire:

Route A (Specific Provisions) is prescriptive and consists in meeting or exceeding, for example, the minimum dimensions and cover thickness for reinforced concrete members and minimum insulation thickness for steel members.

Routes B (Ordinary Verification Method) and C (Advanced Verification Method) are performance-based. Route B includes Verification Methods that are prescriptive, but deemed to satisfy the performance requirements. Route C is intended for new technology, requires approval of the cabinet minister in charge, and allows the use of advanced methods, but these are not provided by the building code.

Route B is now described. The **technical criteria** for fire-resistive performance are stated in BSL-J Article 107 Technical criteria re. fire resistive performance (2011 Enforcement Order p. 83):

1. **Stability:** When exposed to a normal fire (ISO 834 or ASTM E119), structural members must not undergo damage detrimental to structural resistance for given periods, e.g., for beams and columns, 1 h for the 4 uppermost stories, 2 h for the next 10 stories down, and 3 h for the 15th (counting from the top) and lower stories.
2. **Insulation:** For 1 h in a normal fire, the temperature of surfaces not directly exposed to fire must not reach the ignition temperature of combustibles (maximum 200°C, average 160°C on surface).
3. **Integrity:** When exposed to a normal fire for 1 h, exterior walls and roofs must not crack or undergo damage that could allow the fire to spread.

The “Fire Resistance Verification Method” operates in the time domain and can be used to prove compliance with these functional requirements. The main idea is to ensure that the critical time to failure  $t_{fr}(S)$  under service load  $S$  exceeds the fire duration  $t_f$ .

$$t_{fr}(S) > t_f$$

Details on how to satisfy this criterion will be described in later chapters.

## 2.3 Load combinations involving fire

The last part of this chapter deals with load combinations from various countries involving fire.

### 2.3.1 AISC 2011 14<sup>th</sup> Ed. Appendix 4 Structural Design for Fire Conditions ASCE 7-10 Minimum Design Loads for Buildings and Other Structures 2010

In the US, based on the work of Ellingwood and Corotis (1991), the load combination that applies to fires is the one for extraordinary events:

$$(0.9 \text{ or } 1.2) D + A_k + 0.5 L + 0.2 S \quad (2.5.1- ASCE 7-10)$$

where  $A_k$  = extraordinary event, which includes fire,  $D$  = dead load,  $L$  = live load, and  $S$  = snow load. The dead load is multiplied by 0.9 if it has a stabilizing effect, otherwise it is multiplied by 1.2 as in the other load combinations. The companion loads are multiplied by a factor less than 1 because of the small probability of joint occurrence of fire and the design live, snow or wind load. The wind term  $0.2 W$  present in previous editions has been replaced by a requirement to check for lateral stability.  $0.5 L$  and  $0.2 S$  correspond approximately to the mean of the yearly maximum of live and snow loads.

### 2.3.2 Eurocode

From Eurocode EN 1990 “Basis of structural design”, the load combination involving fire is:

$$1.0 D + Fire + 1.0 IP + \gamma_1 INP + \gamma_2 W$$

where  $IP$  = imposed, permanent load,  $INP$  = Imposed, non-permanent load, and  $W$  = wind load.  $\gamma_1 = 1.0$  for  $INP$  in escape stairs and lobbies,  $\gamma_1 = 0.5$  for  $INP$  in offices for general use, and  $\gamma_1 = 0.8$  for  $INP$  in all other areas. In particular snow load on roofs may be ignored.  $\gamma_2 = 0$  when designing for boundary conditions to control external fire spread, and  $\gamma_2 = 0.33$  in all other cases.

### 2.3.3 Australia / New Zealand Standard AS/NZS 1170.0.2002

From Australia / New Zealand Standard AS/NZS 1170.0.2002, the load combination for ultimate limit state for fire is:

$$G + \text{thermal actions arising from the fire} + \psi_e Q$$

where

$G$  = permanent action (self-weight or “dead” action);

$Q$  = imposed action (due to occupancy and use, “live” action);

$\psi_e$  = factor for determining quasi-permanent values (long term) of actions;

$\psi_e = 0.4$  for floors of residences, offices, parking, retail, and  $\psi_e = 0.6$  for storage and other uses.

### 2.3.4 2010 National Building Code of Canada (NBCC)

Tables 4.1.3.2A and B of division B list all load combinations, including dead, live, snow, wind, earthquakes, and cranes, but none of them involve fire. According to Appendix A, load combinations involving fire are relegated to Commentary A of the User’s Guide. Fire is treated as an accidental load and the following load combination applies:

$$D + T_S + (\alpha L \text{ or } 0.25 S)$$

$\alpha = 1.0$  for storage areas, equipment areas and service rooms, and 0.5 for other occupancies (the basis for the factor of 0.5 is the work by Ellingwood and Corotis, 1991);  $D$  = dead load;  $L$  = live load;  $S$  = snow load; and  $T_s$  = short-term, variable effect caused by imposed deformations due to variations in temperature or moisture content or a combination thereof.  $T_s$  can be taken as zero for statically determinate structures.

### **2.3.5 The Building Standard Law of Japan August 2011:**

From The Building Standard Law of Japan August 2011 p. 554 (2004), p. 115 (2011): when calculating resistance to fire, the full dead and live loads (plus snow load where relevant) are applied.

$$1.0 D + Fire + 1.0 L$$

## **2.4 Critical assessment**

All prescriptive building codes and standards surveyed specify fire rating depending on occupancy, type of structure and structural component, and based on criteria of stability, integrity (ignition of material separated from fire by barrier with required integrity, propagation of smoke) and insulation (maximum and average temperatures on surfaces not directly exposed to fire). Of the testing methods used to establish fire rating, ASTM E 119 puts particular emphasis on restrained versus unrestrained end conditions of beams and floor and roof assemblies.

There is also general agreement on the objectives and a framework for performance-based structural design against fire. Eurocode is the most detailed in listing three methods of analysis available (individual structural member, part of the structure, or the entire structure) and the level of sophistication required for each method. AISC lists two methods of analysis, simple or advanced, depending on whether the effects of temperature on boundary conditions are accounted for or not. It is recommended that US performance-based codes develop methodology for analyzing parts of a structure most affected by fire.

For the foreseeable future, a dual approach, prescriptive and performance-based, will continue to be used. Compliance with performance-based codes can be attained by using prescriptive methods deemed as acceptable solutions. On the other hand, most prescriptive codes include an equivalency clause that allows the use of performance-based methods to satisfy the intent of the code.

## **References**

American Concrete Institute (2007) "ACI 216.1-07/TMS 0216-07 Code requirements for Determining fire Resistance of Concrete and Masonry Assemblies," Farmington Hills, MI

American Institute of Steel Construction Steel (2011) "AISC Construction Manual, Appendix 4: Structural Design for Fire Conditions," 14<sup>th</sup> Ed. Chicago, IL, USA

American Society of Civil Engineers (2007) *“ASCE/SEI/SFPE 29-05 Standard Calculation Methods for Structural Fire Protection,”* Reston, VA, USA

American Society of Civil Engineers (2010) *“ASCE 7-10 Minimum Design Loads for Buildings and Other Structures,”* Reston, VA, USA

ASTM E119 (2012) *“Standard Test Methods for Fire Tests of Building Construction and Materials,”* American Society for Testing and Materials, West Conshohocken, Pa

Australian Building Codes Board (2012) *“Building Code of Australia,”* National Construction Code Series Vol. 1, Part C, Fire Resistance, Canberra, ACT, Australia

Australia / New Zealand Standard AS/NZS 1170.0.2002 *“Structural Design Actions: Part 0: General Principles,”* (previously NZS 4203:1992, AS 1170.1-1989 and AS 2867-1986), Sydney, NSW, Australia and Wellington, NZ

Buchanan, A.H. (2001) *“Structural Design for Fire Safety,”* John Wiley & Sons, Ltd., Chichester, UK

Building Center of Japan (2011) *“The Building Standard Law of Japan,”* Tokyo, Japan

Canadian Institute of Steel Construction (2010) *“Commentary on CSA S16-09 Annex K: Structural design for Fire conditions,”* CISC, Markham, Ontario, Canada

Canadian Standards Association (2004) *“CAN/CSA-S16-01 Limit States Design of Steel Structures,”* Toronto, ON, Canada

Canadian Standards Association (2004) *“CSA A23.3-04 Design of Concrete Structures,”* Toronto, ON, Canada

Ellingwood B. and Corotis R.B. (1991) *“Load combinations for buildings exposed to fires,”* Engg. J. AISC 28 (1) 37-44

Eurocode 1 (2010): *“Actions on Structures Part 1-2: General Actions - Actions on Structures Exposed to Fire,”* DIN EN 1991 1-2:2010-12, CEN, Brussels, Belgium

Eurocode EN 1990:2002 (2010) *“Basis of structural design,”* CEN, Brussels, Belgium

International Code Council (2012) *“Performance Code for Buildings and Facilities”* Country Club Hills, IL, USA

ISO 834-8:2002 *“Fire resistance tests -- Elements of building construction,”* International Organization for Standardization, Ch. de la Voie-Creuse, CP 56 CH-1211, Geneva 20, Switzerland

National Research Council Canada (2010) *“National Building Code of Canada 2010”* (NBCC), Institute of Research in Construction, Ottawa, ON, Canada

New Zealand Building Regulations (1992, reprinted 2012), Wellington, NZ

Phan, L.T., McAllister, T.P., Gross, J.L. and Hurley, M.J. (2010) "Best Practice Guidelines for Structural Fire Resistance Design of Concrete and Steel Buildings," NIST TN 1681, National Institute of Standards and Technology, Gaithersburg, MD 201899

Prestressed Concrete Institute PCI (2011) "*Design for fire resistance of precast/prestressed concrete,*" 3<sup>rd</sup> ed. Chicago, IL, USA

Society for Fire Protection Engineering (2007) "*SFPE Engineering Guide to Performance-based Fire Protection,*" 2<sup>nd</sup> ed., Bethesda, MD, USA

Standards Australia (1998) "AS 4100-1998 Steel Structures," Sydney, NSW, Australia

Standards Australia (2009) "AS 3600-2009 Concrete structures," Sydney, NSW, Australia

Standards New Zealand (2007) "*NZS 3404 Part 1: 1997 (with Oct. 2007 amendments, currently applicable in 2013) Steel Structures*", Wellington, NZ

Standards New Zealand (2008) "*NZS 3101 Part 1: 2006 (with Aug. 2008 amendments, currently applicable in 2013) Concrete Structures*", Wellington, NZ

Takagi, J. and Deierlein, G.G. (2009) "Proposed design equations for CAN/CSA S16 Appendix K Provisions for steel members at high temperatures," Report prepared for the Canadian Institute of Steel Construction, Jan. 22

# Chapter 3 Fire Exposure

The question of what fire to design or rate a building for is of fundamental importance. All building codes use standard fires and, in the case of performance-based design, more realistic, physically-based fires, which include compartment fires and localized fires (pre-flashover fires in large spaces, § 3.4).

## 3.1 Standard fires

Standard fire tests serve to compare the relative performance of building materials and small-scale assemblies, although they may not be representative of actual fires. Temperatures in most standard fires continue to rise over time whereas actual fires have growth, full development and decay phases. Furthermore, standard fire tests cannot approximate the full-scale complex structural performance of buildings, which includes the effects of thermal expansion, connection behavior, large deflections, possible loss of stability, and development of alternative load paths. In addition, furnace temperatures have uncertainties up to 100°C (ASCE Engineering Practice No. 114 (2009) Appendix A), and furnace tests often involve short-span specimens, which may require a difficult extrapolation to full-scale.

### 3.1.1 ASTM E119 (2012) Standard Test Methods for Fire Tests of Building Construction and Materials

The standard fire prescribed by ASTM E119 is used by various building and fire codes in the US and around the world to define the period of resistance before a building element being tested loses its structural integrity or its ability to contain the fire. A time-temperature curve (Fig. 3.1) is defined and used in a furnace to heat the element to be tested, which is also loaded to the appropriate load condition specified under nationally recognized structural design criteria. A close approximation of the ASTM E119 curve is provided by Lie (2002):

$$T = 750 \left( 1 - e^{-3.79553\sqrt{t_h}} \right) + 170.41\sqrt{t_h} + 20$$

where  $T$  = temperature °C and  $t_h$  = time in hours.

The test specimen is deemed acceptable if it can sustain the applied load during the fire resistance test without passage of flame or gases hot enough to ignite cotton waste for a period ( $t_{class}$ ) equal to that for which classification is desired. For walls or partitions, and *restrained* or *unrestrained* beams and floor and roof assemblies, transmission of heat should not raise the temperature on the unexposed surface more than 250°F (139°C) above its initial temperature.

For loaded columns, the condition of acceptance is the ability to sustain load for the desired period. For unloaded, protected columns, the condition of acceptance is that the heat transmitted through the protection does not raise the average steel temperature at any one of four sections above 1000°F (538°C) or does not raise the steel temperature above 1200°F (649°C) at any measured point.

The conditions of acceptance take into account the stiffness of contiguous construction. If connections have sufficient rigidity to resist thermal expansion and rotation, fire resistance is improved. Thus, the conditions of acceptance are stricter for beams and floor and roof assemblies with unrestrained ends than with restrained ends (Table 3.1). The average temperature limit in Table 3.1 corresponds to the temperature at which half of *the tensile strength* of high strength alloy steel bars, or cold-drawn prestressing steel, and half of *the yield strength* of hot rolled steel have been lost (ACI 216.1-07).

**Table 3.1 Conditions of acceptance for beams and floor and roof assemblies**

Ends	Type	Spacing	Max. temp. ≤	Average temp. ≤	Duration
Restrained	steel	> 4 ft > 1.2 m	1300°F 704°C	1100°F 593°C	$t \geq t_{class}/2$ and $t \geq 1$ h
	steel	≤ 4 ft ≤ 1.2 m	1300°F 704°C	1100°F 593°C	$t \geq t_{class}/2$ and $t \geq 1$ h
	PC*	> 4 ft > 1.2 m	1300°F 704°C	800°F 427°C	$t \geq t_{class}/2$ and $t \geq 1$ h
	RC*	> 4 ft > 1.2 m	1300°F 704°C	1100°F 593°C	$t \geq t_{class}/2$ and $t \geq 1$ h
Unrestrained	steel	> 4 ft > 1.2 m	1300°F 704°C	1100°F 593°C	$t \geq t_{class}$
	steel	≤ 4 ft ≤ 1.2 m	1300°F 704°C	1100°F 593°C	$t \geq t_{class}$
	PC*		1300°F 704°C	800°F 427°C	$t \geq t_{class}$
	RC*		1300°F 704°C	1100°F 593°C	$t \geq t_{class}$

\*For prestressed (PC) and reinforced concrete (RC), temperatures are measured at tension steel.

For loaded, unrestrained beams supporting floors and roofs, the specimen should sustain the applied load during the rating period. The specimen is deemed as not sustaining the applied load when *both* the following conditions are exceeded: a maximum total deflection of  $L_c^2/(400d)$ , and *after the total deflection has been exceeded*, a maximum deflection rate per minute determined over 1 min interval of  $L_c^2/(9000d)$ , where  $L_c$  = clear span of the beam and  $d$  = beam depth from extreme fiber to extreme fiber.

### 3.1.2 ASTM E1529-13 Standard Test Methods for Determining Effects of Large Hydrocarbon Pool Fires on Structural Members and Assemblies

This standard applies to hydrocarbon processing industry facilities and other facilities potentially subjected to these types of fires. The specified fire exposure provides an average total cold wall heat flux on all exposed surfaces of 50 000 Btu/h/ft<sup>2</sup> (158 kW/m<sup>2</sup>) to be attained within 5 min of test exposure and maintained for the duration of the test. The temperature of the environment that generates this heat flux is at least 1500°F (815°C) after the first 3 min of the test, and between 1850°F (1010°C) and 2150°F (1180°C) at all times after the first 5 min of the test (Fig. 3.1). This test gets hotter faster than ASTM E119, which is equivalent to a heat flux of 11 100 Btu/h/ft<sup>2</sup> (35 kW/m<sup>2</sup>) at 5 min and 37 400 Btu/h/ft<sup>2</sup> (118 kW/m<sup>2</sup>) at 60 min.

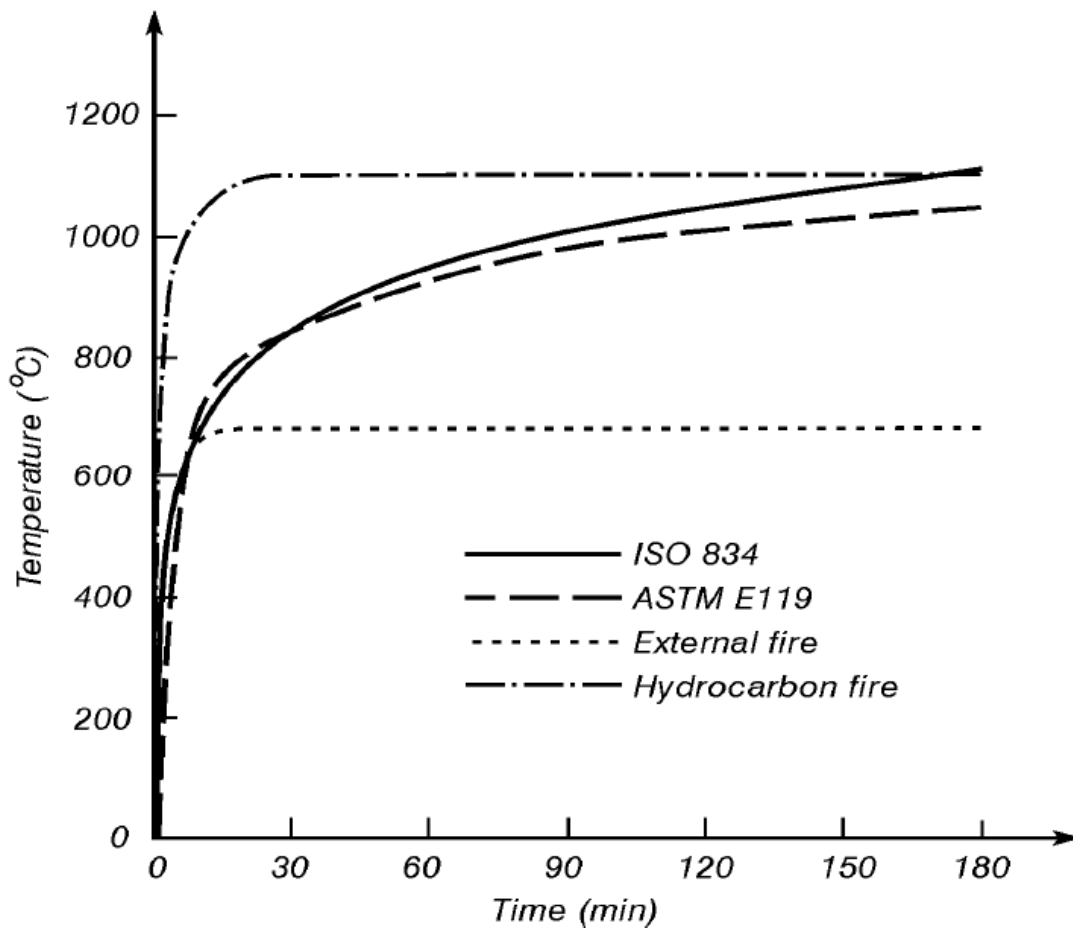

Figure 3.1 Standard time-temperature curves (Phan et al. 2010 NIST TN 1681)

### 3.1.3 Other standard time-temperature curves

#### 2010 National Building Code of Canada (NBCC)

In Canada, fire resistance rating (FRR) is determined based on CAN/ULC-S101 “Fire endurance tests of building construction and materials.” The time-temperature curve is identical to ASTM 119 (Parkinson and Kodur, 2006). FRR can also be assigned on the basis of calculations shown in Appendix D of NBCC. Supporting members should have an FRR not less than that of the supported members. FRR will be addressed in more detail in Chapters 4, 5, 6 and 7.

#### Eurocode

In Europe, a number of other fire curves are used (Eurocode 1, Part 1-2, 2010). The following notation is used:  $\theta_g$  = gas temperature °C,  $t$  = time (min).

ISO 834 Standard temperature-time curve (fig. 3.1), which is very close to ASTM E119:

$$\theta_g = 345 \log_{10} (8t + 1) + 20$$

External fire curve:

$$\theta_g = 660 (1 - 0.687 e^{-0.32t} - 0.313 e^{-3.8t}) + 20$$

Hydrocarbon fire curve:

$$\theta_g = 1080(1 - 0.325 e^{-0.167t} - 0.675 e^{-2.5t}) + 20$$

Most standard fire temperature continues to rise with time, whereas the temperature in an actual fire decreases after reaching a maximum temperature.

### 3.1.4 Time equivalence

Standardized fire tests are applied for the purpose of designing fire protection or selecting member size to ensure that the temperature in individual protected structural members and components does not exceed a limiting value over a given time. Time is the measure specified in building codes and depends on the building use, height and area. How to compare the severity of different fire tests or real fires has been the subject of much research.

#### Equal area

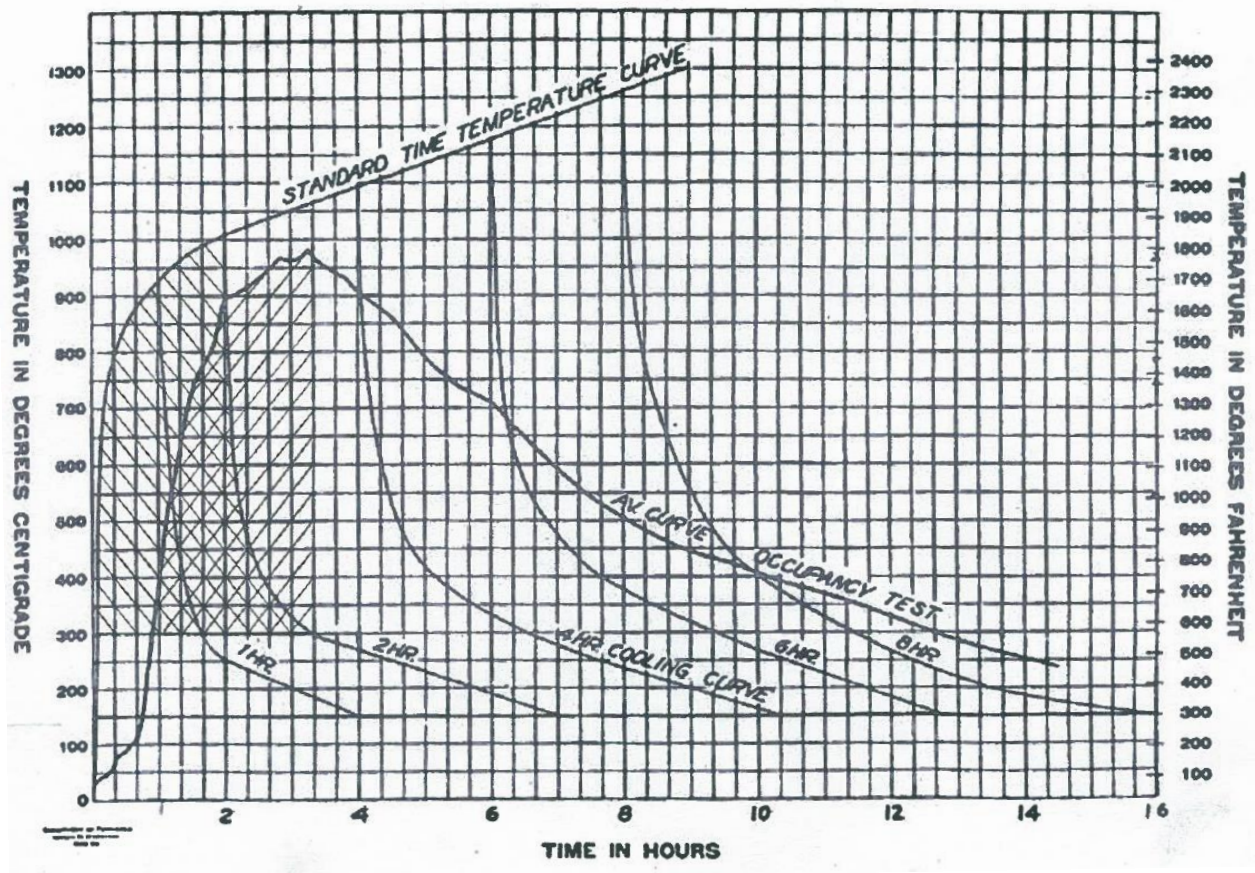

Figure 3.2 Standard time-temperature curve used in furnace tests, cooling curves, curves representing the temperatures in a typical occupancy test, and equivalent areas. Adapted from Ingberg (1928).

Ingberg (1928) developed the equal area method, whereby an approximate comparative measure of fire severity is obtained by assuming that the area under the average temperature-time curve from a burn-out test, expressed in degree-hours, gives severity equivalent to an equal area under the standard curve and the cooling curve applicable for the given period. Only temperatures above a baseline are important for both the standard curve and the occupancy test curve. Ingberg recommended a baseline of 150°C, which is the ignition point for ordinary combustible materials, and 300°C for incombustible structural

members. In Fig. 3.2, adapted from Ingberg's (1928) paper, an occupancy fire test lasting 3 h 20 min is equivalent to a 3 h standard fire, the last hour of which is taken by the temperature decay curve. Ingberg compared the area under the time-temperature curve of burn-out tests with standard fire tests, neglecting the area below 300°C, and developed the following time-equivalence:

$$t_e = k_1 L''$$

where  $t_e$  = time equivalent (min),  $L''$  = fire load (wood) per unit floor area (kg/m<sup>2</sup> or lbm/ft<sup>2</sup>), and  $k_1 = 1$  min·m<sup>2</sup>/kg or 5 min·ft<sup>2</sup>/lbm. This formula assumes that the area under any time-temperature curve from ignition through decay provides a comparative measure of fire severity, which in turn is only a function of the fire load. Ingberg's work became widely accepted as the basis for establishing fire endurance, but its limitations include neglect of the effects of ventilation, fuel type, fuel and compartment geometry, and boundary properties. The equal temperature method overcomes some of these limitations, but is much more complicated.

### Equal temperature

Consider a structural element under a real post-flashover fire. If the same element is subjected to a standard fire such as ISO 834 and attains the same maximum temperature as in the real fire after a time  $t_e$ , then  $t_e$  is defined as the equivalent severity of the real fire. This equal temperature concept accounts for the effects of fuel load density, ventilation openings, compartment dimensions, and enclosure thermal properties, and is more realistic than the equal area concept. Eurocode 1, Part 1-2, Annex F (2002) defines the fire exposure equivalent to a standard fire exposure, depending on

- the design fire load density,
- the ventilation factor,
- a material correction factor, and
- a conversion factor that depends on the thermal properties of the enclosure.

The Eurocode defines the time-equivalent as follows:  $t_e = q_{f,d} k_b w_f k_c$  (min)

Each of the parameters is explained below:

$q_{f,d}$  = fire load density on floor area (MJ/m<sup>2</sup>)  $q_{f,d} = q_{f,k} m \delta_{q1} \delta_{q2} \delta_n$  where

$q_{f,k}$  = fire load density dependent on occupancy (e.g., average for office space is 420 MJ/m<sup>2</sup>);

$m$  = combustion factor (e.g., 0.8 for cellulosic materials);

$\delta_{q1}$  = compartment size fire activation risk factor (e.g., 1.10 for 25 m<sup>2</sup>);

$\delta_{q2}$  = occupancy type fire activation risk factor (e.g., 1.00 for offices, hotels, and residences);

$\delta_n$  = active firefighting factor (e.g., 0.61 for automatic water extinguishing system);

$k_b$  = boundary thermal properties factor, defaults to 0.07 min·m<sup>2</sup>/MJ;

$k_c$  = material correction factor for structural sections ( $k_c = 1$  for protected steel or concrete,  $k_c = 13.7 \times O$  for unprotected steel,  $O$  = opening factor defined below);

$w_f$  = ventilation factor, calculated as follows:

$$w_f = \left(\frac{6}{H}\right)^{0.3} \left[0.62 + \frac{90(0.4 - \alpha_v)^4}{1 + b_v \alpha_h}\right] \geq 0.5$$

where

$\alpha_v = A_v/A_f$  = ratio of the area of façade vertical openings to the compartment floor area  $0.025 \leq \alpha_v \leq 0.25$ ;  
 $\alpha_h = A_h/A_f$  = ratio of the area of roof horizontal openings to the compartment floor area;  
 $b_v = 12.5 (1 + 10 \alpha_v - \alpha_v^2) \geq 10$ ;  
 $H$  = compartment height.

For small fire compartments (defined in the Eurocode as  $A_f \leq 100 \text{ m}^2$ ) without roof openings,  $w_f$  may be calculated as:

$$w_f = \frac{A_f}{A_t \sqrt{O}}$$

where

$O = A_v \sqrt{h}/A_t$  with  $0.02 \leq O \leq 0.20$  is the opening factor; and  
 $A_t$  = total area of inside compartment surfaces, including window area.

The design is deemed to satisfy code if the design time-equivalent  $t_{e,d}$  is less than the design value of the standard fire resistance of the members  $t_{f,d}$ . Time equivalent methods only apply after flashover has occurred. They are essentially refined versions of simple element performance in fire, they cannot address frame performance or structure bearing capacity. Furthermore, the equivalent times are empirical and should not be used in situations beyond the specific compartment test data upon which the formulas are based (Lane 2008).

### 3.2 Eurocode parametric fire curves

For performance-based design, Eurocode allows the use of simple fire models based on physical parameters. Eurocode parametric time-temperature curves have a heating phase and a cooling phase, are based on the equal temperature method, and deal with the temperature evolution in a more realistic fashion than a standard fire does. Eurocode 1, Part 1-2, Annex A describes the parametric temperature-time curves for post-flashover fires. In the heating phase:

$$\theta_g = 20 + 1325 \left( 1 - 0.324 e^{-0.2t^*} - 0.204 e^{-1.7t^*} - 0.472 e^{-19t^*} \right)$$

$$t^* = \Gamma t$$

where

$\theta_g$  = gas temperature;

$t^*$  = modified or scaled time;

$t$  = time (h);

$\Gamma$  = a function of compartment properties (size of openings, properties of boundaries, etc.  $\Gamma = 1$  yields the ISO 834 standard fire,  $\Gamma < 1$  for more slowly growing fires, and  $\Gamma > 1$  for faster growing fires.

$$\Gamma = \left( \frac{O/0.04}{b/1160} \right)^2$$

$$0.02 \leq O = \frac{A_v}{A_t} \sqrt{h_{eq}} = \text{opening factor} \leq 0.20$$

$$100 \leq b = \sqrt{\rho c \lambda} \leq 2200 \text{ value at ambient temperature may be used for } b$$

$A_v$  = total area of vertical openings on all walls;  
 $A_t$  = total area of enclosure (walls, ceiling and floor, including openings);  
 $h_{eq}$  = weighted average of window heights on all walls;  
 $\rho$  = density of boundary enclosure (;  
 $c$  = specific heat of boundary enclosure;  
 $\lambda$  = thermal conductivity of boundary enclosure.

The maximum temperature  $\theta_{max}$  in the heating phase occurs at

$$t_{max}^* = \Gamma t_{max}$$

$$t_{max} = \max \left[ \frac{0.0002 q_{t,d}}{O}; t_{lim} \right]$$

$$50 \leq q_{t,d} = q_{f,d} A_f / A_t \leq 1000 \text{ MJ/m}^2$$

where

$q_{t,d}$  = design value of fire load density related to total surface area  $A_t$  of the enclosure;  
 $q_{f,d}$  = design value of fire load density related to floor area  $A_f$ ;  
 $t_{lim}$  = time of maximum temperature for fuel controlled fires (= 15, 20, 25 min for fast, medium and slow fire growth respectively);  
 $\frac{0.0002 q_{t,d}}{O}$  is the time of maximum temperature for ventilation controlled fires.

In the cooling phase:

$$\theta_g = \theta_{max} - 625(t^* - x t_{max}^*) \quad \text{for } t_{max}^* \leq 0.5$$

$$\theta_g = \theta_{max} - 250(3 - t_{max}^*)(t^* - x t_{max}^*) \quad \text{for } 0.5 < t_{max}^* < 2$$

$$\theta_g = \theta_{max} - 250(t^* - x t_{max}^*) \quad \text{for } t_{max}^* \geq 2$$

where

$$t_{max}^* = \Gamma \frac{0.0002 q_{t,d}}{O}$$

$$x = 1.0 \text{ if } t_{max} > t_{lim}; \text{ or } x = \frac{\Gamma t_{lim}}{t_{max}^*} \text{ if } t_{max} = t_{lim}$$

Eurocode 1, Part 1-2, Annex E specifies

- fire load densities, which include factors for combustion,
- activation risk,
- firefighting measures, as well as
- characteristic fire load densities for various occupancies.

### 3.3 Design fires and fire scenarios

Unlike design fires for smoke control or egress time, design fires for structural assessment are mostly concerned with post-flashover fires. The reasons are that structures are affected by peak temperatures and fire duration beyond the incipient and growth phases of a fire. The following paragraphs emphasize compartment fires, but it is important to note that, for very large spaces with specific pockets of fuel, such as an airport terminal, flashover is unlikely to occur, and local fires affecting one or two columns in a long span structure may be more relevant.

#### 3.3.1 SFPE S.01 2011 SFPE Engineering standard on calculating fire exposures to structures

The standard covers fully developed fires, arising from within an enclosure, or from a localized fire not affected by an enclosure. All **required design fire scenarios** have exposure greater than or equal to 30 kW. The required enclosure fire scenarios are:

1. Most likely compartment, space or area that could be involved in a fire;
2. Compartment, space or area with the largest potential or anticipated mass of combustible material;
3. Compartment, space or area with the largest potential volume;
4. Compartment, space or area containing structural elements that may lead to structural failure upon exposure to design fire.

The required local fire scenarios, discussed at the end of the chapter, are:

5. Compartment, space or area with the largest potential concentrated fuel load;
6. An external fire that exposes the structure.

#### Potential for flashover

The potential for flashover is based on consideration of wall linings, compartment geometry, ventilation, and fuel quantity and orientation. For rectangular parallelepiped spaces that a) are not too large; b) have one or more vertical openings; c) have known thermal conductivity and thickness of compartment lining materials; d) have a width to depth ratio between 0.5 and 2.0; and e) have no mechanical ventilation or flow-through wind, the heat release rate required for flashover can be estimated by one of the following two methods:

Method of McCaffrey, Quintiere and Harkleroad (1981):

$$\dot{Q} = 610(h_k A A_0 \sqrt{H_0})^{1/2}$$

$$h_k = \sqrt{k\rho c/t}$$

Method of Thomas (1981):

$$\dot{Q} = 7.8A + 378A_0\sqrt{H_0}$$

where

$\dot{Q}$  = heat release rate required for flashover (kW);

$h_k$  = effective heat transfer coefficient (kW/m<sup>2</sup>/K);

$A$  = total surface area of compartment (m<sup>2</sup>);

$A_0$  = total opening area (m<sup>2</sup>);

$H_0$  = height of opening (m);

$k$  = thermal conductivity of wall lining material (kW/m/K);

$\rho$  = density of compartment surface material (kg/m<sup>3</sup>);

$c$  = specific heat of compartment surface material (kJ/kg/K);  
 $t$  = exposure time (s).

For all other cases, engineering analysis methods should be used, with the criterion that flashover occurs when the upper layer temperature exceeds 600°C or the heat flux to the floor exceeds 20 kW/m<sup>2</sup>.

### Enclosure fires

SFPE S.01 2011 recommends two methods to calculate the post-flashover gas temperature evolution in a compartment.

Method 1: assumes a constant fire temperature of 1200°C after a growth time and until burnout, when the fuel is consumed, after which the temperature decays at a rate of 7 °C/min. The burnout time  $\tau_b$  is given by:

$$\tau_b = \frac{EA_f}{90A_0\sqrt{H_0}}$$

where  $A_f$  = floor area (m<sup>2</sup>).

Method 2: Tanaka's refined method (1996) calculates the ventilation controlled post-flashover transient fire temperatures for the room of origin.

$$T = \beta_{F,1}(2.50 + \beta_{F,1})T_\infty + T_\infty, \quad \text{for } \beta_{F,1} \leq 1.00$$

$$T = \beta_{F,1}(4.50 - \beta_{F,1})T_\infty + T_\infty, \quad \text{for } \beta_{F,1} > 1.00$$

where

$$\beta_{F,1} = \left( \frac{A_0\sqrt{H_0}}{A} \right)^{1/3} \left( \frac{t}{k\rho c} \right)^{1/6}$$

$T$  = temperature of enclosure (K);

$T_\infty$  = 300 K;

$A$  = total surface area of compartment, excluding openings (m<sup>2</sup>).

The mass burning rate is (Kawagoe and Sekine, 1963):  $\dot{m} = 0.1 A_0\sqrt{H_0}$

and the burnout time is:  $\tau_b = M/\dot{m}$ , where

$M$  = mass of available combustible material (kg);

$\dot{m}$  = mass burning rate (kg/s).

### 3.3.2 NFPA 5000 Building Construction and Safety Code Handbook (2003)

Ch. 5 Performance-based option

According to the NFPA 5000 Building Code, at a minimum, a fire scenario consists of the following:

1. Ignition factors (source, location and material);
2. At least one heat release rate curve;
3. Occupant locations;
4. Occupant characteristics;
5. Special factors (shielded, systems unreliable, open door).

NFPA 5000 recommends the following methods to select fire scenarios:

- a. statistical analysis of fire experience of similar buildings, e.g., fast fire growth in room contents, to select common scenarios;

- b. refine common scenarios, e.g., flammable liquids in means of egress, to select high challenge scenarios;
- c. special problems, e.g., sprinklers or fire detector out of commission, to select special scenarios.

More specifically, NFPA recommends eight fire scenarios:

1. Occupancy-specific and representative of typical fire for that occupancy. This first scenario must explicitly specify the following: occupant activities; number and location of occupants; room size; furnishings and contents; fuel properties and ignition sources; ventilation conditions; first item ignited and its location. Example: a hospital room with two occupied beds, fire initially involving one bed and room door open.
2. Ultrafast developing fire in the primary means of egress, with interior doors open at the start of the fire. This scenario is intended to address reduction in the number of available means of egress. Example: fire in clothing rack in corridor.
3. Fire starts in a normally unoccupied room that can endanger a large number of occupants in other areas. Example: fire starts in a storage room adjacent to the largest occupiable room in the building.
4. Fire originates in a concealed wall space or ceiling space adjacent to a large, occupied room.
5. A slow developing fire, shielded from fire protection systems, close to a high occupancy area. Example: cigarette in a trash can.
6. Most severe fire resulting from the largest possible fuel load characteristic of normal operation.
7. Outside fire exposure.
8. Fire originates in ordinary combustibles in a room where each active or passive fire protection feature is rendered ineffective.

### 3.3.3 NFPA 557 Standard Determination of Fire Loads for Use in Structural Fire Protection Design (2012)

This document provides standard methods and values for fire loads in a risk framework.

The frequency of structurally significant fires  $f_{ss}$  is calculated as follows:

$$f_{ss} = c \times f_f \times A_f$$

where

$c$  = fraction of fires that are structurally significant;  $f_f$  = fire frequency (fires/m<sup>2</sup>/year);

$A_f$  = floor area (m<sup>2</sup>). The fire frequency  $f_f$  is given for various occupancies:

**Table 3.2 Fire frequency**

Occupancy	Fire frequency (fires/m <sup>2</sup> /year)
Office, business	6×10 <sup>-6</sup>
Religious properties	6×10 <sup>-6</sup>
Eating, drinking establishments	81×10 <sup>-6</sup>
Other public assembly buildings	10×10 <sup>-6</sup>
Educational buildings	10×10 <sup>-6</sup>
Facilities that care for the sick	16×10 <sup>-6</sup>
Stores, mercantile buildings	16×10 <sup>-6</sup>
Places where people sleep other than homes	43×10 <sup>-6</sup>

The fraction  $c$  depends on the occupancy, the type of construction and the fire protection.

**Table 3.3 Fraction  $c$  of structurally significant fires in office/business occupancies**

Type of construction	No detection No alarm No sprinklers	No detection No alarm Sprinklers present	Detection present Alarm present No sprinklers	Detection present Alarm present Sprinklers present
Fire resistive	0.13	0.04	0.07	0.03
...				
Unprotected wood frame	0.37	0.12	0.20	0.07

The fire load density  $Q_f$  is the sum of the fixed fire load density  $Q_{f,f}$  and the contents fire load density  $Q_{f,c}$ .

$$Q_f = Q_{f,f} + Q_{f,c}$$

The mean and variance of the sum are the sum of the means and variances.

$$\overline{Q_f} = \overline{Q_{f,f}} + \overline{Q_{f,c}}$$

$$\sigma_f^2 = \sigma_{f,f}^2 + \sigma_{f,c}^2$$

**Table 3.4 Fire load density**

Fire load density	Occupancy or construction	Mean	Standard deviation
Contents	Office, business	600 MJ/m <sup>2</sup>	500 MJ/m <sup>2</sup>
Fixed	Non-combustible	130 MJ/m <sup>2</sup>	40 MJ/m <sup>2</sup>

If a more detailed fire load density needs to be calculated, the heat of combustion for products made entirely of wood or products with fire performance superior to that of non-fire retarded materials can be assumed to be 15 MJ/kg unless specific information is available.

The design fire load density  $Q_{fd}$  is a function of the risk objective  $F$ .

$$Q_{fd} = \overline{Q_f} - \frac{\sqrt{6}}{\pi} \sigma_f [0.577 + \ln(-\ln F)]$$

$$F = 1 - \frac{R_s}{f_{ss}}$$

where

$R_s$  = risk performance criterion for structural collapse (say 10<sup>-6</sup>/year).

### 3.3.4 AISC 2011 14<sup>th</sup> Ed. Appendix 4 Structural Design for Fire Conditions.

Design-basis fires should take into account the fuel load characteristic of occupancy and the heat flux or temperatures for the duration of the fire. Alternatively, ASTM E119 may be used. The kinds of fire that need to be considered include localized fire, post-flashover compartment fires, and exterior fires. Active fire protection systems need to be accounted for.

### **3.3.5 ISO/TS 16733 (2006) “Fire Safety Engineering- Selection of design fire scenarios and design fires”**

ISO/TS 16733 (Hadjisophocleous and Mehaffey, 2008) recommends the following steps for identifying and selecting fire scenarios:

1. Location of fire;
2. Type of fire (smoldering, pre- or post-flashover);
3. Potential fire hazards (from intended use of facility);
4. Systems impacting on fire (fire safety systems);
5. Occupant response;
6. Event tree (alternative event sequences);
7. Consideration of probability;
8. Consideration of consequence;
9. Risk ranking;
10. Final selection and documentation.

The potential fire locations to be considered are:

1. Fires in rooms with large number of occupants or valuable property;
2. Fires that render parts of means of egress unusable;
3. Fires that commence within building assemblies and remain undetected while growing in intensity in concealed places;
4. Localized fires and/or post-flashover fires that could challenge the structure and compartmentalization in the building;
5. Fire locations that are challenging for proposed active measures (e.g., fires that are shielded from sprinkler sprays, fires at center of a space that generate large volume of smoke).

### **3.3.6 Eurocode**

Eurocode 1, Part 1.2, Annex D, 2002 allows the use of advanced fire models for post-flashover conditions, for example, one-zone models, where homogeneous conditions prevail through the compartment; two-zone models, where combustion products accumulate in a layer beneath the ceiling, with a horizontal interface; and computational fluid dynamics models.

The many factors that affect fire development include:

- Form of ignition source;
- Type of fuel first ignited;
- Secondary fuel ignited and fire spread;
- Location of fire;
- Compartment geometry;
- Time of doors and windows closing or opening;
- Ventilation;
- Type of construction and interior finish materials;
- Form of intervention (fire suppression systems, fire department, etc.).

Part of the characterization of the design fire scenario is the establishment of a design fire curve, which typically encompasses ignition, growth (pre-flashover), flashover (fully developed phase), and post-flashover (decay and burnout phases).

Factors that affect whether flashover occurs or not include:

- Surface area of enclosure  $A$ ;
- Area of enclosure openings  $A_0$ ;
- Effective height of openings  $H_0$ ;
- Heat release rate of fuel;
- Ventilation;
- Thermal properties of compartment boundaries.

Trial designs are developed in order to propose fire protection systems, construction features and operations to meet performance criteria using design fire scenarios. Trial designs are evaluated and selected based on effectiveness, reliability, availability and cost.

### 3.3.7 New Zealand Building Regulations 1992, reprinted 10 April 2012

**Table 3.5 List of 10 fire design scenarios**

	<b>Design scenario</b>	<b>Expected method</b>
	Keeping people safe	
BE	Fire blocks exit	Solved by inspection
UT	Fire in a normally unoccupied room threatening occupants of other rooms	ASET/RSET analysis or provide separating elements /suppression compliant with a recognized standard
CS	Fire starts in a concealed space	Provide separating elements/suppression or automatic detection compliant with a recognized standard
SF	Smoldering fire	Provide automatic detection and alarm system compliant with a recognized standard
IS	Rapid fire spread involving surface linings	Suitable materials used (proven by testing)
CF	Challenging fire <sup>1</sup>	ASET/RSET analysis
RC	Robustness check <sup>2</sup>	Modified ASET/RSET analysis
	Protecting other property	
HS	Horizontal fire spread	Calculate radiation from unprotected areas as specified
VS	Vertical fire spread	Suitable materials used (proven by testing) and construction features specified (e.g., aprons/spandrels /sprinklers) as required to limit vertical fire spread.
	Firefighting operations	
FO	Firefighting operations	Demonstrate firefighter safety

<sup>1</sup>The *challenging fires* are intended to represent credible worst case scenarios in normally occupied spaces that will challenge the fire protection features of the building.

<sup>2</sup>*Robustness check*: The fire design is checked to ensure that the failure of a critical part of the fire safety system will not result in the design not meeting the objectives of the Building Code, which include structural stability during and after fire.

A series of documents called Verification Methods or Acceptable Solutions are published to provide one way to show compliance with the New Zealand Building Regulations (1992). Other ways are explained in general terms in the main document. C/VM2 (Ministry of Business, Innovation and Employment, 2013) provides the framework for fire safety design and sets out ten *design scenarios* (Table 3.5) that must be considered and designed for, where appropriate, in order to achieve compliance with NZBC C:

Protection from Fire (Dept. of Building and Housing Extract, 2012). A flowchart is provided to guide the designer through the process, taking into account the number of occupants, occupants' characteristics, building use, availability of sprinklers, etc. C/VM2 uses the following acronyms:

FLED = fire load energy density MJ/m<sup>2</sup>;

ASET = available safe egress time;

RSET = required safe egress time.

### Design fire characteristics

Analysis for a number of the *design scenarios* is based on the use of '*design fires*'. These are defined by one or more of the following parameters:

- a) Fire growth rate
- b) Peak heat release rate (HRR)
- c) Fire load energy density (FLED)
- d) Species production (CO, CO<sub>2</sub>, water, soot)
- e) Heat flux, and
- f) Time.

Verification Method C/VM2 also provides parameters and modeling instructions for the various phases of design fires.

### Pre-flashover design fires

In most cases (i.e., for all *buildings*, including storage *buildings*, that are capable of storage to a height of less than 3.0 m) the *pre-flashover design fire* is assumed to grow as a fast  $t^2$  fire (fire growth rate (W) =  $46.9 t^2$  with  $t$  in seconds), up to *flashover* or until the HRR reaches the peak (20 MW) or becomes ventilation limited. See Table 3.6 for other buildings.

**Table 3.6 Pre-flashover design fire characteristics**

Building use	Fire growth rate (W)	Species	Radiative fraction	Peak HRR
All <i>buildings</i> including storage with a stack height of less than 3.0 m	$46.9 t^2$	$Y_{soot} = 0.07 \text{ kg/kg}$	0.35	20 MW
Carparks (no stacking)	$11.7 t^2$	$Y_{CO} = 0.04 \text{ kg/kg}$		50 MW
Storage with a stack height between 3.0 m and 5.0 m above the floor	$188 t^2$	$\Delta H_c = 20 \text{ MJ/kg}$ $Y_{CO2} = 1.5 \text{ kg/kg}$		
Storage with a stack height of more than 5.0 m above the floor and car parks with stacking systems	$0.68 t^3 H$	$Y_{H2O} = 1.0 \text{ kg/kg}$		

NOTE:  $t$  = time in seconds;  $H$  = height of storage in m;  $Y$  = yield kg/kg;  $\Delta H_c$  = heat of combustion

### Post-flashover design fires

*Flashover* is assumed to occur when the average upper layer temperature first reaches 500°C. For uncontrolled *fires*, the burning rate is assumed to be governed by the ventilation limit or the peak HRR,

whichever is less. Post-flashover fires are unlikely to be required in the modeling of sprinklered buildings.

### Full burnout design fires

**Table 3.7 Design Fire Load Energy Density (FLED) for use in modeling fires in C/VM2**

Design FLED (MJ/m <sup>2</sup> )	Activities in the space or room	Examples
400	1. Display or other large open spaces; or other spaces of <i>low fire hazard</i> where the occupants are awake but may be unfamiliar with the <i>building</i> .	1. Art galleries, auditoriums, bowling alleys, churches, clubs, community halls, court rooms, day care centres, gymnasiums, indoor swimming pools
	2. Seating areas without upholstered furniture	2. School classrooms, lecture halls, museums, eating places without cooking facilities
	3. All spaces where occupants sleep	3. <i>Household units</i> , motels, hotels, hospitals, residential care institutions
	4. Working spaces and where <i>low fire hazard</i> materials are stored	4. Wineries, meat processing plants, manufacturing plants
	5. Support activities of <i>low fire hazard</i>	5. Car parks, locker rooms, toilets and amenities, service rooms
800	1. Spaces for business	1. Banks, personal or professional services, police stations (without detention)
	2. Seating areas with upholstered furniture, or spaces of moderate <i>fire hazard</i> where the occupants are awake but may be unfamiliar with the <i>building</i>	2. Nightclubs, restaurants and eating places, <i>early childhood centres</i> , cinemas, <i>theatres</i> , libraries
	3. Spaces for display of goods for sale (retail, non-bulk)	3. Exhibition halls, shops and other retail (non bulk)
1200	1. Spaces for working or storage with moderate <i>fire hazard</i>	1. Manufacturing and processing moderate <i>fire load</i> 2. Storage up to 3.0 m high other than <i>foamed plastics</i>
	2. Workshops and support activities of moderate <i>fire hazard</i>	3. Maintenance workshops, plant and boiler rooms
400/tier of car storage	Spaces for multi-level car storage	Car stacking systems. The design floor area over which the design <i>FLED</i> applies is the total actual car parking area
800/m height, with a minimum of 2400	1. Spaces for working or storage with high <i>fire hazard</i>	1. Chemical manufacturing and processing, feed mills, flour mills 2. Storage over 3.0 m high of <i>combustible</i> materials, including climate controlled storage
	2. Spaces for display and sale of goods (bulk retail)	3. Bulk retail (over 3.0 m high)

The ‘full *burnout design fire*’ for structural design and for assessing the *fire* resistance of *separating elements* is based on complete *burnout* of the *firecell* with no intervention. For the *full burnout design fire*, all the fuel shown in Table 3.7 is allowed to burn. There are three choices for modeling the full *burnout design fire*:

- a) Use a time-equivalent formula to calculate the equivalent *fire* severity and specify *building elements* with a *fire resistance rating* not less than the calculated *fire* severity. If the calculated value is less, an equivalent *fire* severity of 20 minutes is used. The time equivalence formula is taken from Annex E of Eurocode DD ENV 1991-2-2.
- b) Use a parametric time versus gas temperature formula to calculate the thermal boundary conditions (time/temperature) for input to a structural response model, or
- c) Construct an *HRR* versus time structural *design fire*. Then, taking into account the ventilation conditions, use a *fire* model or energy conservation equations to determine suitable thermal boundary conditions (time/temperature/flux) for input to a structural response model.

### 3.3.8 AS 1530.4 – 2005 Methods for fire tests on building materials, components and structures

Standard heating conditions are similar to those of Eurocode, where  $T$  is in °C, and  $t$  is in min.

$$T = 345 \log_{10} (8 t + 1) + 20$$

### 3.3.9 The Building Standard Law of Japan August 2011

As mentioned in Chapter 2, the “fire resistance verification method” can be used to prove compliance with the functional requirements. The main idea is to ensure that the critical time to failure  $t_{fr}(S)$  under service load  $S$  exceeds the fire duration  $t_f$ .

$$t_{fr}(S) > t_f$$

In order to satisfy this inequality, the fire duration is first defined.

**Table 3.8 Fire load density  $q_f$  per unit floor area: excerpt from Notification 1433**

Category	Fire load density MJ/m <sup>2</sup>
dwelling	720
office	560
classroom	400
restaurant	480
theater	400
parking garage	240
storage	2000

**Fire duration  $t_f$  (min)**

$$t_f = \frac{Q_r}{60 q_b}$$

where

$Q_r$  = fire load (MJ). See Table 3.8;

$q_b$  = heat release rate of combustible material in compartment (MW). See Table 3.9.

**Table 3.9 Heat release rate  $q_b$ : excerpt from Notification 1433**

Burn factor	Heat release rate $q_b$ (MW)
$x \leq 0.081$	$1.6 x A_{fuel}$
$0.081 < x \leq 0.1$	$0.13 A_{fuel}$
$x > 0.1$	$(2.5 x e^{-11x} + 0.048)A_{fuel}$

where

$$x = \text{burn factor} = \frac{f_{op}}{A_{fuel}} = \max \left\{ \sum \left( \frac{A_{op} \sqrt{H_{op}}}{A_{fuel}}, \frac{A_r \sqrt{H_r}}{70 A_{fuel}} \right) \right\}$$

$$f_{op} = \text{effective ventilation factor (m}^{5/2}\text{)} = \max \left\{ \sum \left( A_{op} \sqrt{H_{op}}, \frac{A_r \sqrt{H_r}}{70} \right) \right\}$$

$A_{op}$  = area of openings in walls, floor and ceiling (m<sup>2</sup>);

$H_{op}$  = vertical distance from top edge to bottom edge of openings in walls, floor and ceiling (m);

$A_r$  = floor area (m<sup>2</sup>);

$H_r$  = average height of ceiling above floor (m);

$A_{fuel}$  = surface area of combustibles =  $0.26 q_l^{1/3} A_r + \sum \phi A_f$

$q_l$  = fire load density (MJ/m<sup>2</sup>)

$A_f$  = areas of interior surface finish of floor, walls and ceiling (m<sup>2</sup>);

$\phi$  = oxygen consumption coefficient.

The fire load  $Q_r$  consists of the fuel load from the floor plus the finish parts of walls, floor and ceiling of the room in question and adjoining rooms. In this summation, the fire loads from adjoining rooms are multiplied by heat penetration coefficients that depend on openings.

### Fire severity and duration

Mc Caffery's parametric equation for post-flashover compartment fires is used. The fire temperature  $T_f$  (°C) is a power function of time  $t$  (min):

$$T_f = \alpha t^{1/6}$$

$\alpha$  is the fire temperature rise coefficient (°C/min<sup>1/6</sup>) and balances heat released by combustibles and lost through boundaries and openings:

$$\alpha = 1280 \left( \frac{q_b}{\sqrt{\sum (A_c I_h)} \sqrt{f_{op}}} \right)^{2/3}$$

where

$A_c$  = surface area of walls, floor and ceiling of compartment (m<sup>2</sup>);

$I_h$  = thermal inertia =  $\sqrt{k\rho c}$  unless listed otherwise (in table in Notification 1433 p. 98);

$k$  = thermal conductivity (kW/m/K);

$\rho$  = mass density (kg/m<sup>3</sup>);

$c$  = specific heat (kJ/kg/K)

The standard fire temperature curve ISO 834 is approximated closely by  $\alpha = 460 \text{ }^\circ\text{C}/\text{min}^{1/6}$  (Kohnno 2006).

A local fire temperature rise coefficient  $\alpha_l$  is also provided to account for the height  $z$  of a structural member above the floor (Table 3.10). This assumes a localized fire that grows to 3 MW in 20 minutes (Harada et al. 2004).

**Table 3.10 Local fire temperature rise coefficient: excerpt from Notification 1433**

$z$ (m)	$\alpha_l$
$z \leq 2$	500
$2 < z \leq 7$	$500 - 100(z - 2)$
$z > 7$	0

### 3.4 Localized fire exposure

For very large spaces (with an open floor area greater than  $465 \text{ m}^2$  or  $5000 \text{ ft}^2$ ) with specific pockets of fuel, or rectangular rooms with aspect ratios greater than 5, flashover is unlikely to occur, and local fires affecting one or two columns in a long span structure may be more relevant. Examples include airport terminals, shopping malls, warehouses and factories.

#### 3.4.1 SFPE S.01 2011 Engineering standard on calculating fire exposures to structures

SFPE recommends checking two local fire scenarios:

1. Compartment, space or area with the largest potential concentrated fuel load.
2. An external fire that exposes the structure.

#### Localized fire exposure

The document provides guidance for the total incident heat flux and fire duration for surfaces that are immersed or in contact with the thermal plume or flame zone of a concentrated fuel load. The methods presented apply to fires greater than 30 kW and specific geometric configurations. The incident heat flux to structural members should not be less than  $20 \text{ kW}/\text{m}^2$ , which is the threshold for ignition of common combustible materials in an enclosure. The design fire should be the most severe fire exposure in terms of incident heat flux and exposure duration for a given fuel package.

a) Unconfined fire and fire below ceiling:

$$\text{Maximum flame height: } F_h = H - 1.02 D_{eff} + 0.23(\dot{Q})^{0.4}$$

where

$F_h$  = maximum flame height (m);

$H$  = fuel package height (m);

$\dot{Q}$  = heat release rate (kW);

$D_{eff}$  = effective fire diameter;  $\pi D_{eff}^2/4 = L W$

$L$  = length of fuel package (m);

$W$  = width of fuel package (m).

Three cases are of interest:

1.  $F_h \geq H_T$  (height of exposed object):

The exposure heat flux is  $120 \text{ kW}/\text{m}^2$  and the fire duration  $\tau_d$  (s) is:

$$\tau_d = \frac{M \cdot \Delta H_c}{\left(\frac{H_T + 1.02 D_{eff}}{0.23}\right)^{5/2}}$$

where  $\Delta H_c$  = effective heat of combustion (kJ/kg).

2.  $H_T > F_h \geq H_T/2$

The exposure heat flux is 20 kW/m<sup>2</sup> and the fire duration is:

$$\tau_d = \frac{M \cdot \Delta H_c}{\left(\frac{H_T/2 + 1.02 D_{eff}}{0.23}\right)^{5/2}}$$

3.  $H_T/2 > F_h$

The method is not applicable.

b) Fire adjacent to wall – with or without ceiling effect:

The exposure heat flux is 120 kW/m<sup>2</sup> and the fire duration is:

$$\tau_d = \frac{M \cdot \Delta H_c}{\dot{Q}}$$

c) Fire adjacent to corner – with or without ceiling effect:

1. If  $F_h < H_T/2$ , heat flux < 20 kW/m<sup>2</sup> and method is not applicable.

2. For  $F_h \geq H_T/2$ , the maximum flame height is:  $F_h = H + 0.03 D_{eff} \left(\frac{\dot{Q}}{D_{eff}^{5/2}}\right)^{1/2}$ .

If  $F_h \geq H_T$ , the exposure heat flux is 120 kW/m<sup>2</sup> and the fire duration is:

$$\tau_d = \frac{M \cdot \Delta H_c}{\left(\frac{H_T - H}{0.03 D_{eff}}\right)^2 D_{eff}^{5/2}}$$

If  $H_T/2 \leq F_h < H_T$ , the exposure heat flux is 20 kW/m<sup>2</sup> and the fire duration is:

$$\tau_d = \frac{M \cdot \Delta H_c}{\left(\frac{H_T/2 - H}{0.03 D_{eff}}\right)^2 D_{eff}^{5/2}}$$

### 3.4.2 Localized fires from Eurocode Annex C DIN EN 1991 1-2:2010-12

#### Eurocode 1: Actions on Structures Part 1-2: General Actions-Actions on Structures Exposed to Fire,

Annex C gives the flame vertical length  $L_f$  (m) of a localized fire as a function of the fire diameter  $D$  (m) and heat release rate  $Q$  (W):

$$L_f = -1.02 D + 0.0148 Q^{2/5}$$

If the flame is not impacting the ceiling, the temperature  $\theta(z)$  in the plume along the vertical axis of the flame is given by:

$$\theta(z) = 20 + 0.25 Q_c^{2/3} (z - z_0)^{-5/3} \leq 900$$

where

$Q_c$  = convective part of heat release rate,  $Q_c = 0.8 Q$  by default,  $Q$  = heat release rate;

$z$  = height from floor along flame axis (m);

$z_0 = -1.02 D + 0.00524 Q^{2/5}$  = virtual origin of axis.

If the flame impacts the ceiling, the heat flux  $\dot{h}$  (W/m<sup>2</sup>) on the ceiling is given by:

$$\begin{aligned} \dot{h} &= 100\,000 \quad \text{if } y \leq 0.30 \\ \dot{h} &= 136\,300 \text{ to } 121\,000 y \quad \text{if } 0.30 < y < 1.0 \\ \dot{h} &= 15\,000 y^{-3.7} \quad \text{if } y \geq 1.0 \\ y &= \frac{r + H + z'}{L_h + H + z'} \end{aligned}$$

where

$r$  = radial coordinate of point on ceiling where heat flux is calculated;

$H$  = vertical distance to ceiling from fire source;

$z'$  = vertical coordinate of virtual heat source (equivalent point source);

$$z' = 2.4 D \left( Q_D^{*2/5} - Q_D^{*2/3} \right) \quad \text{when } Q_D^* < 1.0$$

$$z' = 2.4 D \left( 1.0 - Q_D^{*2/5} \right) \quad \text{when } Q_D^* \geq 1.0$$

$$Q_D^* = \frac{Q}{1.11 \cdot 10^6 \cdot D^{2.5}}$$

The horizontal flame length at the ceiling level, measured from the flame axis is:

$$L_h = 2.9 H Q_H^{*0.33} - H$$

$$Q_H^* = \text{non-dimensional heat release rate} = \frac{Q}{1.11 \cdot 10^6 \cdot H^{2.5}}$$

### 3.5 Critical Assessment

All building codes studied use standard fire time-temperature curves for comparing the relative performance of building materials and small-scale assemblies, designing fire protection, and selecting structural member sizes through fire resistance ratings (in hours). Standard fire temperature curves continue to rise with time, whereas the temperature in an actual fire decreases after reaching a maximum temperature. Parametric fires, which are based on physical parameters, attempt to deal with the temperature evolution in a more realistic fashion. In the US, SFPE recommends a number of parametric fire models that are comparable to those of Eurocode. However, the time of exposure to a standard fire equivalent to a real fire (to achieve the same maximum temperature) is more clearly defined by Eurocode than by US standards.

The best measure of the accuracy of any time-temperature relationship for enclosure fires is by comparison with experimental results. One of the more extensive data sets is the CIB (Conseil International du Batiment), which consists of 321 tests conducted in a coordinated international testing program (Thomas and Heselden, 1972). Based on a comparison of various formulas for calculating the temperature at various times in a compartment fire, Thomas (2008) concludes that it is better to rely on well-documented and well-tested computer models. The reasons for this conclusion include:

- . For many enclosures of practical significance, the assumption of uniformity of conditions is not valid.
- . The maximum temperature measured anywhere in an enclosure may grossly overestimate fire severity in particular locations.
- . Major changes in maximum temperatures and fire duration occur, particularly for low ventilation.
- . The manner of ignition has little effect on maximum temperatures and duration of burning.
- . The lining materials have significant effect on both maximum temperature and duration of burning.

Law (1997) reviewed time-equivalent formulas and generally concluded that they do not accurately represent fire temperature and duration, especially in deep compartment fires, and do not differentiate between short, hot fires and longer, cooler fires that have the same equivalent time.

Researchers have suggested various modifications to the Eurocode parametric curves based on comparison with output from program COMPF2 (Babrauskas, 1979). ASCE (2009) compares Eurocode time-temperature parametric curves with the proposed modified Eurocode curves, as well as curves proposed by Lie and by Petterson for various values of thermal inertia, fuel load, and ventilation factor. ASCE (2009) notes that the modified Eurocode curves predict the highest fire severity.

Most of the building codes studied also have elaborate recommendations on the fire scenarios that a building should be designed for. Unlike design fires for smoke control or egress time, design fires for structural assessment are mostly concerned with post-flashover fires. In the US, both NFPA and SFPE provide extensive recommendations on the fire scenarios to be investigated, and these are comparable to the fire scenarios listed in Eurocode and ISO. Of all the documents studied, the New Zealand Building Regulations have the most detailed fire scenarios, with design Fire Load Energy Densities for various spaces and occupancies.

According to data contained in CIB W14 (1986), the total fuel load in a typical office ranges between  $635 \text{ MJ/m}^2$  and  $3900 \text{ MJ/m}^2$ . The wood equivalent, assuming an average heat of combustion of  $12.5 \text{ MJ/kg}$ , is  $35 \text{ kg/m}^2$  to  $217 \text{ kg/m}^2$  of floor area. This generally agrees with the range suggested by SFPE and NFPA as likely to produce a ventilation-controlled fire, which forms the basis for design (ASCE 2009).

For very large spaces, post-flashover fires are unlikely to occur and local fires affecting one or two columns in a long span structure may be more relevant. SFPE and Eurocode are at a comparable level of sophistication on localized fires.

## References

AISC (2011) *"AISC Construction Manual, Appendix 4: Structural Design for Fire Conditions,"* 14<sup>th</sup> Ed. American Institute of Steel Construction Steel, Chicago, IL, USA

AS 1530.4 – 2005 “Methods for fire tests on building materials, components and structures”, Standards Australia, Sydney, NSW, Australia

ASCE Manuals and Reports on Engineering Practice No. 114 (2009) “Performance-Based Design of Structural Steel for Fire conditions,” Parkinson, D.L., Kodur, V. and Sullivan, P.D., ed.

ASTM E119 (2012) “Standard Test Methods for Fire Tests of Building Construction and Materials,” American Society for Testing and Materials, West Conshohocken, Pa

ASTM E1529-13 (2013) “Standard Test Methods for Determining Effects of Large Hydrocarbon Pool Fires on Structural Members and Assemblies,” American Society for Testing and Materials, West Conshohocken, Pa

Babrauskas, V. (1979 “COMP2-A Program for Calculating Post-Flashover Fire Temperatures,” NBS TN 991, National Bureau of Standards, Washington, DC

Building Center of Japan (2011) “*The Building Standard Law of Japan*,” Tokyo, Japan

CIB W14 Workshop (1986) “Design Guide - Structural Fire Safety”, Fire Safety J. vol. 10, no. 2, pp. 77-137

Dept. of Building and Housing (2012) “Extract from the New Zealand Building Code: Clauses C1-C6: Protection from Fire, and Clause A3: Building Importance Levels”, Wellington, NZ

Eurocode 1: Actions on Structures Part 1-2: General Actions-Actions on Structures Exposed to Fire DIN EN 1991 1-2:2010-12, including Annex A, Annex C, Annex D, 2002, Annex E, Annex F, 2002

Hadjisophocleous, G. and Mehaffey, J.R. (2008) “Fire Scenarios,” SFPE Handbook of Fire Protection Engineering 4<sup>th</sup> ed. Chapter 5.11

Harada, K., Ohmiya, Y., Natori, A., Nakamichi, A. (2004) “Technical basis on structural fire resistance design in building standards law of Japan” Fire and Materials, 28:323-341 DOI:10.1002/fam.857

Ingberg, S.H. (1928) “Tests of the severity of building fires,” Quarterly of the National Fire Protection Association, vol. 22, no. 1, July, pp. 43-61, Boston, MA

ISO/TS 16733 (2006) “Fire Safety Engineering- Selection of design fire scenarios and design fires,” International Organization for Standardization, Geneva, Switzerland

Kawagoe, K. and Sekine, T. (1963) “Estimation of Fire Temperature-Time Curve in Rooms,” Occasional Report No.11, Building Research Institute, Tokyo, Japan

Kohno, M. (2006) “Outline of the fire resistance verification method in the Building Standard Law of Japan” 38th Joint Meeting US-Japan Panel on Wind and Seismic Effects, 15-20 May, Gaithersburg, MD

Lane, B. (2008) “Approaches to calculating structural fire resistance,” NFPA Fire Protection Handbook, 12<sup>th</sup> ed., Vol. II, Chap. 19.5, Cote, A.E. Ed. National Fire Protection Association, Quincy, MA. USA pp. 19.77-19.126

Law, M. (1997) "Review of Formulae for T-Equivalent," Fire Safety Science, Proc. 5<sup>th</sup> Int. Symp., pp.985-996.

Lie, T.T. (2002) "Fire Temperature-Time Relations," Hdbk Fire Protection Engg, 3<sup>rd</sup>. ed. Chapter 4.8, SFPE, Bethesda, MD

McCaffrey, B.J. , Quintiere, J.G. and Harkleroad , M.F. (1981) "Estimating Room Temperatures and the Likelihood of Flashover Using Fire Test Data Correlations," Fire Technology, Vol. 17, No. 2, pp. 98-119

Ministry of Business, Innovation and Employment (2013) "C/VM2 Verification Method: Framework for Fire Safety Design for New Zealand Building Code Clauses C1-C6 Protection from Fire," Wellington, NZ

National Research Council Canada (2010) "National Building Code of Canada 2010" (NBCC), Institute of Research in Construction, Ottawa, ON, Canada

New Zealand Building Regulations (1992, reprinted 2012), Wellington, NZ

NFPA 5000 (2003) "Building construction and safety code handbook," Ch. 5 Performance-based option, National Fire Protection Association, Quincy, MA

NFPA 557 (2012) "Standard Determination of Fire Loads for Use in Structural Fire Protection Design," National Fire Protection Association, Quincy, MA

Parkinson, D.L. and Kodur, v. (2006) "Performance-Based Design of Structural Steel for Fire conditions: a Calculaiton Methodology," ASCE Structures Congress, St. Louis, MO

Phan, L.T., McAllister, T.P., Gross, J.L. and Hurley, M.J. (2010) "Best Practice Guidelines for Structural Fire Resistance Design of Concrete and Steel Buildings," NIST TN 1681, National Institute of Standards and Technology, Gaithersburg, MD 201899

SFPE S.01 (2011) "SFPE Engineering standard on calculating fire exposures to structures," Society for Fire Protection Engineering, Bethesda, MD

Tanaka, T., Sato, M. and Wakamatsu, T. (1996) "Simple Formula for Ventilation Controlled Fire Temperatures," 13th US/Japan Government Cooperative Program on Natural Resources (UJNR), Gaithersburg, MD, NISTIR 6030 June 1997 pp. 341-356 also Fire Science and Technology, 1997, Vol. 17, No. Special Issue, pp. 15-27

Thomas. P.H. (1981) "Testing products and materials for their contribution to flashover in rooms," Fire Materials, 5:103-111

Thomas, I. (2008) "Enclosure Fire Temperature-Time Estimation," SPFE Hdbk of Fire Protection Engineering , 4<sup>th</sup> ed. , ©SPFE, NFPA Pub., Quincy, MA, pp. 4.208-4.227

Thomas, P. and Heselkden, A (1972) "fully Developed Fires in Single Compartments," CIB Rept. 20, Fire Research Note 923, Fire Research Station, Borehamwood, UK

# Chapter 4 Steel Structures

This chapter covers the design of steel structures to resist fire, according to various national building codes and guidance documents. Traditionally, prescriptive methods have been specified to achieve a certain fire resistance rating measured in exposure time to a standard fire. More recently, performance-based methods have been developed to calculate the resistance of structural members exposed to more realistic fires, taking into account the decreased strength and stiffness of steel at elevated temperatures.

## 4.1 Prescriptive methods

### 4.1.1 USA: ASCE/SEI/SFPE 29-05 Standard Calculation Methods for Structural Fire Protection

This standard provides methods to calculate the equivalent fire resistance, in terms of hours, of concrete, timber, masonry and steel members that would be achieved under the standard ASTM E119 fire test, or by comparative engineering analysis. This standard does not provide any guidance about the structural performance of members or structures under fire.

**Columns:** The procedures for determining the fire resistance  $R$  (in hours) of column assemblies (i.e., steel columns encased in insulation) are based on the mass per unit length  $W$  (lbm/ft or kg/m) or the cross sectional area  $A$  (in<sup>2</sup> or mm<sup>2</sup>), the heated perimeter  $D$  or  $P$  (in or mm) of the steel section, and the thickness  $h$  (in or mm) of the fire protection.

For gypsum wallboard protection:

$$R = c_1 \left( \frac{h W'}{2 D} \right)^{0.75}$$
$$W' = W + c_2 h D$$

where

$c_1 = 2.17$  (h, in, lbm);  $c_1 = 1.60$  (h, mm, kg);

$W'$  = total mass per unit length of steel column and protection.

$c_2 = 50/144$  lbm, ft;  $c_2 = 0.0008$  kg, m

For spray-applied protection on wide-flange columns:

$$R = (C_1 W/D + C_2)h$$

For spray-applied protection on tubular columns:

$$R = C'_1 h A/P + C'_2$$

where  $C_1$ ,  $C_2$ ,  $C'_1$  and  $C'_2$  are material constants.

**Concrete-filled hollow steel columns:** In addition to  $W$ ,  $D$  and  $h$ ,  $R$  (in hours) is also dependent on the concrete specified compressive strength  $f'_c$  (ksi or MPa), the column effective length  $KL$  (ft or mm) and the compressive force due to the unfactored dead and live loads  $C$  (kips or kN).

$$R = 0.58a \frac{f'_c + 2.90}{KL - 3.28} D^2 \sqrt{\frac{D}{C}} \quad \text{or} \quad R = a \frac{f'_c + 20}{60(KL - 1000)} D^2 \sqrt{\frac{D}{C}} \quad \text{SI units}$$

**Columns encased in concrete or masonry:** In addition to some of the quantities listed above, the fire resistance rating  $R$  of steel columns encased in concrete or masonry depends also on the properties of the enclosure, namely moisture content  $m$  (% of volume), thermal conductivity  $k_c$  (Btu/h/ft/°F or W/m/K), thermal capacity  $H$  (Btu/ft/°F or J/m/K), density  $\rho_c$  (lbm/ft<sup>3</sup> or kg/m<sup>3</sup>), specific heat  $c_c$  (Btu/lbm/°F or J/kg/K), thickness  $h$  (in or mm) and side length  $L =$  inside perimeter of protection/4 (in or mm).

$$R = R_0(1 + 0.03m)$$

$$R_0 = 0.17 \left(\frac{W}{D}\right)^{0.7} + 0.28 \frac{h^{1.6}}{k_c^{0.2}} \left[1 + 26 \left(\frac{H}{\rho_c c_c h(L+h)}\right)^{0.8}\right]$$

$$R_0 = 1.22 \left(\frac{W}{D}\right)^{0.7} + 0.0027 \frac{h^{1.6}}{k_c^{0.2}} \left[1 + 31000 \left(\frac{H}{\rho_c c_c h(L+h)}\right)^{0.8}\right] \quad \text{SI units}$$

**Beams, girders and trusses:** The procedure for determining the fire resistance rating  $R$  of beams, girders and trusses is similar to that used for columns. The heated perimeter  $D$  does not include the top of the top flange, which is shielded from direct fire exposure by floor or roof decks. The rating accounts for restrained or unrestrained conditions.

The following formulas are provided to calculate the thickness  $h$  of the spray-applied insulation on a non-standard beam (subscript 2) in relation to a standard, approved beam (subscript 1):

$$h_2 = \left(\frac{W_1/D_1 + 0.60}{W_2/D_2 + 0.60}\right) h_1 \quad W \frac{\text{lbm}}{\text{ft}}, D \text{ and } h \text{ in}$$

$$h_2 = \left(\frac{W_1/D_1 + 0.036}{W_2/D_2 + 0.036}\right) h_1 \quad W \frac{\text{kg}}{\text{m}}, D \text{ and } h \text{ mm}$$

#### 4.1.2 USA: The International Building Code IBC 2012, Chapter 7: Fire and Smoke Protection Features

This standard is based on ASCE/SEI/SPFE 29-05 “Standard Calculation Methods for Structural Fire Protection”, but it does not contain any provision on concrete-filled hollow steel columns, and it treats the fire resistance of steel columns protected by concrete or clay masonry units separately from the fire resistance of steel columns protected by concrete. The standard does not provide any guidance about the structural performance of members or structures under fire.

Table 721.1 of IBC 2012 prescribes the minimum thickness of various types of insulation for various fire resistance ratings (FRR) of structural members. For example, an FRR of 3 h requires a 2 in (50 mm) protective cover of concrete for a steel column.

The FRR of steel assemblies depends on the size of the element and the type of protection provided, and is calculated based on the  $W/D$  concept, i.e., the ratio of average weight per unit length  $W$  to the heated perimeter  $D$ . For a wide-flanged steel column protected with sprayed fire-resistant material for example,  $R = [C_1(W/D) + C_2]h$  where  $R$  is the fire resistance (minutes),  $h$  is the thickness of the insulation (in) and  $C_1$  and  $C_2$  are material constants. The required thickness of sprayed fire-resistant material on larger or smaller steel beams can be calculated from the required thickness for approved restrained or unrestrained beams by the same ASCE ratio mentioned in the previous section.

### 4.1.3 National Building Code of Canada (NBCC) 2010 vol. 2 Appendix D Fire-performance ratings

Section D-2.6 provides the minimum thickness of concrete or masonry protective covering for steel columns. Equivalent thicknesses of plaster or gypsum-sand plaster are also listed. These values are based on the  $M/D$  (kg/m) ratio of the column mass  $m$  to the heated perimeter  $D$  of the column section in m. Section D-2.7 provides the minimum thickness of protective covering for steel beams for FRR between 30 min and 4 h. Table D-2.6.1.A specifies the minimum thickness of concrete or masonry protection for steel columns, e.g., for an FRR of 1h, a monolithic concrete cover of 25 mm is required.

## 4.2 Performance-based methods

Furnace tests are used to determine the fire resistance rating and the thickness of protection for individual structural members. Because the results are directly comparable to furnace tests, the analysis of single members typically form the basis for structural design against fire, whereby all relevant structural responses due to axial force, shear, flexure, buckling, lateral torsional buckling, etc. are verified. With the progress of structural software, the development of faster computers, and the construction of bigger test facilities, progress is being made in moving beyond single member behavior to capture the full frame response, including the effects of thermal expansion, the strength of connections under fire, and the potential development of alternate load paths. Performance-based methods start with various fire exposures described in Chapter 3, then calculate the temperature in the fire-exposed structure.

### 4.2.1 Methods for predicting temperatures in fire-exposed structures

SFPE Fire Protection Engineering, 4<sup>th</sup> ed. 2008

The total heat flux  $\dot{q}_{tot}''$  transferred from a fire to a structural member is:

$$\dot{q}_{tot}'' = \varepsilon_s \sigma (T_r^4 - T_s^4) + h(T_g - T_s)$$

where

$\varepsilon_s$  = emissivity of target surface;

$\sigma$  = Stefan-Boltzman constant =  $5.6696 \times 10^{-8}$  W/(m<sup>2</sup>·K<sup>4</sup>);

$h$  = convective heat transfer coefficient;

$T_g$  = gas absolute temperature;

$T_r$  = radiation absolute temperature;

$T_s$  = surface absolute temperature.

The adiabatic surface temperature  $T_{AST}$ , measured approximately by a plate thermometer, is the temperature of a perfectly insulated surface exposed to radiation and convection, and is defined by:

$$\varepsilon_s \sigma (T_r^4 - T_{AST}^4) + h(T_g - T_{AST}) = 0$$

Then the total heat transfer can be rewritten as:

$$\dot{q}_{tot}'' = \varepsilon_s \sigma (T_{AST}^4 - T_s^4) + h(T_{AST} - T_s)$$

For unprotected steel structures the transient steel temperature is:

$$A_s [\varepsilon_s \sigma (T_{AST}^4 - T_s^4) + h(T_{AST} - T_s)] = c_s \rho_s V_s \frac{\partial T_s}{\partial t}$$

where

$A_s$  = fire exposed area;

$c_s$  = steel specific heat capacity;

$t$  = time;

$V_s$  = volume per unit length of steel section;

$\rho_s$  = steel density.

For insulated steel structures, to a good approximation, the fire exposed surface temperature is the same as the fire temperature, and the total heat transfer  $q_{tot}$  to the steel in steady state is:

$$q_{tot} = A_s (k_i/d_i)(T_f - T_s)$$

where

$k_i$  = thermal conductivity of insulation material;

$d_i$  = thickness of insulation material;

$T_f$  = fire temperature ( $T_r = T_g = T_f$  in fire engineering);

$T_s$  = steel temperature.

If the heat capacity of the insulation is negligible relative to that of steel, transient steel temperature can be obtained from the heat balance equation:

$$A_s \frac{k_i}{d_i} (T_f - T_s) = c_s \rho_s V_s \frac{\partial T_s}{\partial t}$$

For a constant fire temperature rise and constant material properties, the solution is:

$$T_s - T_0 = (T_f - T_0)(1 - e^{-t/\tau})$$

$$\tau = \frac{c_s \rho_s V_s}{A_s (k_i/d_i)} = \frac{c_s \rho_s (d_i/k_i)}{A_s/V_s}$$

where  $\tau$  is the characteristic response time,  $A_s$  the cross section area per unit length of steel section and  $A_s/V_s$  the shape factor or section factor. For heavily insulated sections, a simple approximation is to

lump  $\frac{1}{3}$  of the insulation heat capacity with that of steel (normally the heat capacity of the insulation has an insignificant influence on the temperature rise of the steel section).

#### 4.2.2 Eurocode 3: Design of steel structures- Par 1-2: General rules- structural fire design BS EN 1993-1-2:2005 also DIN EN 1993-1-2:2010-12

Structural fire design must meet two basic requirements:

1. maintain load bearing function during fire;
2. maintain separation requirement between elements by limiting deformations.

Eurocode 3 defines the stress-strain relationship of carbon steel at elevated temperatures as follows:

- a linear, elastic part:

$$\text{for } \varepsilon \leq \varepsilon_p(T) \quad \sigma = \varepsilon E(T)$$

- a nonlinear, transition part:

$$\text{for } \varepsilon_p(T) < \varepsilon < \varepsilon_y(T) \quad \sigma = F_p(T) - c + \frac{b}{a} \sqrt{a^2 - (\varepsilon_y(T) - \varepsilon)^2}$$

- a constant, plastic part:

$$\text{for } \varepsilon_y(T) \leq \varepsilon \leq \varepsilon_t(T) \quad \sigma = F_y(T)$$

- a linear, decreasing part to failure:

$$\text{for } \varepsilon_t(T) < \varepsilon < \varepsilon_u(T) \quad \sigma = F_y(T) \frac{1 - (\varepsilon - \varepsilon_t(T))}{\varepsilon_u(T) - \varepsilon_t(T)}$$

where

$\varepsilon$  = strain;

$\varepsilon_p(T) = F_p(T)/E(T)$  = strain at proportional limit;

$\varepsilon_y(T) = 0.02$  = yield strain;

$\varepsilon_t(T) = 0.15$  = limiting strain for yield strength;

$\varepsilon_u(T) = 0.20$  = ultimate strain;

$\sigma$  = stress;

$E(T)$  = Young's modulus at temperature  $T$ ;

$F_p(T)$  = proportional limit at temperature  $T$ ;

$F_y(T)$  = effective yield strength at temperature  $T$ ;

$$a^2 = (\varepsilon_y(T) - \varepsilon_p(T)) \left( \varepsilon_y(T) - \varepsilon_p(T) + \frac{c}{E(T)} \right)$$

$$b^2 = c (\varepsilon_y(T) - \varepsilon_p(T)) E(T) + c^2$$

$$c = \frac{(F_y(T) - F_p(T))^2}{(\varepsilon_y(T) - \varepsilon_p(T)) E(T) - 2(F_y(T) - F_p(T))}$$

Note that Eurocode defines the yield stress  $F_y$  at 2% strain. The Appendix at the end of this chapter compares the values at various temperatures of the yield stress at 2% strain and at 0.2 % offset (proof or plastic strain). Material properties are reduced from characteristic (room temperature) values by reduction factors that depend on temperature (Fig. 4.1, Table 4.1).

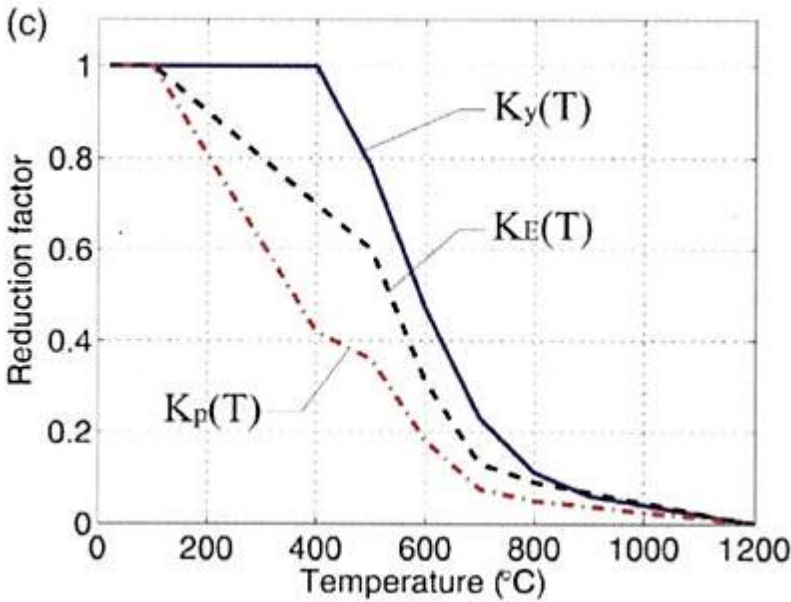

$$K_p(T) = \frac{F_p(T)}{F_{p0}}$$

$$K_y(T) = \frac{F_y(T)}{F_{y0}}$$

$$K_E(T) = \frac{E(T)}{E_0}$$

$F_p$  = proportional limit  
 $F_y$  = yield stress  
 $E$  = Young's modulus

Figure 4.1 Reduction factors for the stress-strain relationship of carbon steel at elevated temperatures (EN 1993-1-2:2010, also Phan et al. 2010 NIST TN 1681)

Table 4.1 Stress-strain reduction factors in EC3

Temperature °C	$K_y(T)$	$K_p(T)$	$K_E(T)$
20	1.000	1.000	1.000
100	1.000	1.000	1.000
200	1.000	0.807	0.900
300	1.000	0.613	0.800
400	1.000	0.420	0.700
500	0.780	0.360	0.600
600	0.470	0.180	0.310
700	0.230	0.075	0.130
800	0.110	0.050	0.090
900	0.060	0.038	0.068
1000	0.040	0.025	0.045
1100	0.020	0.013	0.023
1200	0	0	0

Eurocode defines four classes of cross section, with class 1 the least susceptible to local buckling and class 4 the most susceptible. Class 1 (plastic) cross sections can form plastic hinges with the rotation capacity required for plastic analysis. Class 2 (compact) sections can also develop their plastic moment resistance, but have limited rotation capacity because of local buckling. In class 3 (semi-compact)

sections, the extreme fibers in compression can reach the yield strength, assuming an elastic stress distribution, but local buckling is likely to prevent development of the plastic moment resistance. In class 4 (slender) sections, local buckling will occur before any part of the section reaches yield. The limits between classes are established by the factor:

$$\varepsilon = 0.85 \sqrt{235/F_y}$$

where  $F_y$  is the yield strength in MPa at 20°C and the reduction factor 0.85 accounts for elevated temperatures.

### Simple calculations: the capacity method

Load bearing function is maintained if the design effect of actions for the fire design situation is less than or equal to the corresponding design resistance of the steel member, which is calculated by modifying the resistance at ambient temperature by accounting for the mechanical properties of steel at elevated temperature. Usually, this is done by assuming a uniform temperature in the cross section. [The following notation is adopted from Takagi and Deierlein (2007), and differs slightly from EC3].

#### Tension members:

$$N(T) = K_y(T)N_0$$

$N(T)$  = design tensile resistance at temperature  $T$ ;

$N_0$  = design tensile resistance at ambient temperature;

$K_y(T)$  = reduction factor for yield strength.

#### Compression members:

For members subjected to inelastic flexural buckling (Class 1, 2 and 3 sections), the design buckling resistance  $P_{cr,EC3}(T)$  at a uniform temperature  $T$  is:

$$P_{cr,EC3}(T) = \chi(T) P_y(T)$$

where  $P_y(T)$  is the yield load at  $T$  and  $\chi(T)$  is a reduction factor that depends on the slenderness ratio  $\bar{\lambda}(T)$  and imperfection factor  $\alpha$ .

$$\chi(T) = \frac{1}{\varphi(T) + \sqrt{\varphi^2(T) - \bar{\lambda}^2(T)}} \leq 1.0$$

$$\varphi(T) = 0.5[1 + \alpha\bar{\lambda}(T) + \bar{\lambda}^2(T)]$$

$$\bar{\lambda}(T) = \sqrt{\frac{F_y(T)}{F_e(T)}} = \bar{\lambda}_0 \sqrt{\frac{K_y(T)}{K_E(T)}}$$

$$\alpha = 0.65 \sqrt{235/F_{y0}}$$

where

$\bar{\lambda}_0$  = slenderness ratio at ambient temperature;

$F_y(T)$  = yield stress at  $T$ ;

$F_e(T)$  = Euler buckling stress at  $T$ ;

$F_{y0}$  = yield stress at ambient temperature;

$K_y(T), K_E(T)$  = reduction factors for yield strength and for modulus of elasticity.  
The above formulation is similar to that at ambient temperature (subscript 0)

$$P_{cr0,EC3} = \chi_0 P_{y0}$$

$$\chi_0 = \frac{1}{\varphi_0 + \sqrt{\varphi_0^2 - \bar{\lambda}_0^2}} \leq 1.0$$

$$\varphi_0 = 0.5[1 + \alpha(\bar{\lambda}_0 - 0.2) + \bar{\lambda}_0^2]$$

$$\bar{\lambda}_0 = \sqrt{\frac{F_{y0}}{F_{e0}}} = \frac{KL}{\pi r} \sqrt{\frac{F_{y0}}{E_0}}$$

$$F_{e0} = \frac{\pi^2 E_0}{(KL/r)^2} = \text{Euler buckling stress}$$

where

$0.13 \leq \alpha \leq 0.76$  is an imperfection factor;

$K$  = end fixity factor;

$L$  = column length;

$r$  = radius of gyration.

For column buckling, only curve  $c$  - the more conservative of four possible curves - is used at high temperatures. The use of curve  $c$  is due to a more severe influence of initial imperfections than for ambient conditions and additional bending due to non-uniform temperatures.

### Beams

The design lateral torsional buckling resistance of a laterally unrestrained member with a class 1 or 2 cross section with a uniform temperature is:

$$M_{cr,EC3}(T) = \chi_{LT}(T) M_p(T)$$

where

$M_p(T)$  = plastic moment at temperature  $T$ ;

$\chi_{LT}(T)$  = reduction factor that depends on the slenderness ratio  $\bar{\lambda}_{LT}(T)$  and imperfection factor  $\alpha_{LT}$ .

$\bar{\lambda}_{LT0}$  = slenderness ratio at ambient temperature.

$$\chi_{LT}(T) = \frac{1}{\varphi_{LT}(T) + \sqrt{\varphi_{LT}^2(T) - \bar{\lambda}_{LT}^2(T)}} \leq 1.0$$

$$\varphi_{LT}(T) = 0.5[1 + \alpha_{LT}\bar{\lambda}_{LT}(T) + \bar{\lambda}_{LT}^2(T)]$$

$$\bar{\lambda}_{LT}(T) = \bar{\lambda}_{LT0} \sqrt{\frac{K_y(T)}{K_E(T)}}$$

$$\alpha_{LT} = 0.65 \sqrt{235/F_{y0}}$$

The above formulation is similar to that at ambient temperature (subscript 0).

$$M_{cr0,EC3} = \chi_{LT0} M_{p0}$$

$$\chi_{LT0} = \frac{1}{\varphi_{LT0} + \sqrt{\varphi_{LT0}^2 - \bar{\lambda}_{LT0}^2}} \leq 1.0$$

$$\varphi_{LT0} = 0.5 \left[ 1 + \alpha_{LT} (\bar{\lambda}_{LT0} - 0.2) + \bar{\lambda}_{LT0}^2 \right]$$

$$\bar{\lambda}_{LT0} = \sqrt{\frac{M_{p0}}{M_{cr0,e}}}$$

$$M_{p0} = Z_x F_{y0}$$

$M_{cr0,e}$  is the elastic critical moment for lateral torsional buckling,  $\alpha$  is an imperfection factor that depends on the section proportions, and  $Z_x$  is the plastic section modulus about the strong axis. It is seen that the strength formulations for the flexural buckling of columns and the lateral torsional buckling of beams at ambient and at temperature  $T$  are consistent.

For beam-column strength, EC3 provides the following equations:

$$\frac{P_u}{P_{cry,EC3(T)}} + k_{LT}(T) \frac{M_{ux}(T)}{M_{cr,EC3(T)}} \leq 1.0$$

$$P_{cry,EC3(T)} = \chi(T) P_y(T)$$

$$k_{LT}(T) = 1 - \mu_{LT}(T) \frac{P_u}{P_{cry,EC3(T)}}$$

$$\mu_{LT}(T) = 0.165 \bar{\lambda}_y(T) - 0.15 \leq 0.9$$

where

$P_u$  = factored axial load;

$M_{ux}(T)$  = factored bending moment about the strong axis;

$P_{cr,EC3(T)}$  = critical axial strength for flexural buckling;

$M_{cr,EC3(T)}$  = critical bending moment for lateral torsional buckling;

$\mu_{LT}(T)$  for pin-ended beam-column subjected to uniform end moments.

For class 4 cross sections other than tension members, the load bearing function is assumed maintained if the steel temperature is less than a critical temperature, recommended to be 350°C unless otherwise specified.

### The critical temperature method

As an alternative to the capacity method, verification may be carried out in the temperature domain.

When deformation or stability does not need to be considered, a critical temperature  $\theta_{a,cr}$  for steel can be defined for a uniform temperature distribution and an utilization factor  $\mu_0$ :

$$\theta_{a,cr} = 39.19 \ln \left( \frac{1}{0.9674 \mu_0^{3.833}} - 1 \right) + 482$$

The degree of utilization  $\mu_0$  is the ratio of the design effect of actions for the fire situation (reduced dead and live loads, e.g., 1.0  $D$  + 0.5  $L$  for office occupancy), including the effects of thermal expansion and deformations, to the corresponding design resistance in the fire situation. For unprotected members,  $\theta_{a,cr} = 554^\circ\text{C}$  for  $\mu_0 = 0.60$  and  $\theta_{a,cr} = 526^\circ\text{C}$  for  $\mu_0 = 0.70$  for examples. This temperature is assumed uniform over the cross section, and therefore a lumped mass heat transfer analysis is sufficient

(Lane 2008). Due to instability effects (e.g., lateral torsional buckling) and the sensitivity of various modes of failure to temperature gradients, the strength reduction factors that apply to structural members are not the same as would apply to the material.

The EC3 document includes steel temperature development  $\Delta\theta_{a,t}$  for unprotected steelwork as a function of the net heat flux  $\dot{h}_{net,d}$ , the section factor (ratio of cross section area  $A_m$  to volume  $V$  of member per unit length), material properties (specific heat  $c_a$  and unit mass  $\rho_a$  of steel), a shadow factor  $k_{sh}$ , and time  $\Delta t$ .

$$\Delta\theta_{a,t} = k_{sh} \frac{A_m/V}{c_a \rho_a} \dot{h}_{net,d} \Delta t$$

For protected steelwork, the thickness and thermal properties of insulation are included in the equation.

$$\Delta\theta_{a,t} = \frac{\lambda_p (A_p/V) (\theta_{g,t} - \theta_{a,t})}{d_p c_a \rho_a (1 + \phi/3)} \Delta t - (e^{\phi/10} - 1) \Delta\theta_{g,t}$$

$$\phi = \frac{c_p \rho_p}{c_a \rho_a} d_p A_p/V$$

where

$A_p/V$  = section factor ;

= ratio of cross section area of protection material  $A_p$  to volume of member  $V$  per unit length;

$c_p$  = specific heat of protection material;

$d_p$  = thickness of protection material;

$\rho_p$  = unit mass of protection material;

$\lambda_p$  = thermal conductivity of protection material;

$\theta_{g,t}$  = ambient gas temperature at time  $t$ .

In addition to the simple methods described above, **advanced calculation methods** can be used with any heating curve to calculate the thermal and mechanical responses of the structure. EN 1993-1-2 also includes the following annexes:

Annex A: strain-hardening of carbon steel at elevated temperatures.

Annex B: heat transfer to external steelwork, including beams and columns partially or fully engulfed in flames.

Annex C: stainless steel. Proof strength is defined at 0.2 % plastic strain ( $f_{p0.2}$ , as in US).

Annex D: joints. The strength of bolts and welds is reduced from that at ambient by a temperature-dependent reduction factor listed in Table D1. The temperature of a joint may be calculated from the ratio of exposed area to volume of the connected members in the vicinity of the joint, or from the temperature  $\theta_0$  of the bottom flange at midspan:

$$\begin{aligned} \theta_h &= 0.88 \theta_0 [1 - 0.3 h/D] \text{ for } h \leq 400 \text{ mm} \\ \theta_h &= 0.88 \theta_0 \text{ for } h > 400 \text{ mm and } h \leq D/2 \\ \theta_h &= 0.88 \theta_0 [1 + 0.2(1 - 2 h/D)] \text{ for } h > 400 \text{ mm and } h > D/2 \end{aligned}$$

where

$\theta_h$  = temperature at height  $h$  above bottom of beam;

$D$  = depth of beam.

Annex E: class 4 cross sections

For the design under fire conditions using simplified calculation models, the design yield strength of steel should be taken as the 0.2% proof strength,  $f_{p0.2,\theta}$ , with the reduction factor

$$k_{p0.2,\theta} = f_{p0.2,\theta} / f_y$$

$k_{p0.2,\theta}$  is tabulated in Table E1.

### **Single elements in local heating**

The methodology for single elements applies to post-flashover fires as well as to local fires, where temperature gradients may be more severe, with potential adverse consequences on the stability of columns and frames.

### **Connections in fire**

EC3 states that the fire resistance of a bolted or welded connection may be assumed to be sufficient if the fire protection on the connection is as effective on the joint as it is on the members, and the utilization of the joint is less than or equal to the maximum utilization of any of the connected members.

## **4.2.3 USA: AISC 2011 14<sup>th</sup> Ed. Appendix 4 Structural Design for Fire Conditions**

This appendix has been recently updated with the work of Takagi and Deierlein (2007).

### **Unprotected steel members**

Appendix 4 proposes a formula for the rise in steel temperature that is a function of the weight to perimeter ratio, the difference in temperature between the fire and the steel, and a heat transfer coefficient, which is the sum of a convective and a radiative coefficient. Unfortunately, the radiative coefficient is itself a function of the unknown steel temperature to the third power, and the time step associated with this approach is recommended not to exceed 5 s.

### **Protected steel members**

The simple method is applicable to steel members with contour insulation (i.e., that follows the shape of the section). Application of the method to box insulation will overestimate the steel temperatures. The temperature of the outside surface of the insulation is assumed to be the fire temperature, and temperature in the steel section is determined by thermal conduction through the insulation material. Two formulas are provided, depending on whether the heat capacity of the insulation material can be neglected or not. Ideally material properties used should be functions of temperature, but if these functions are not known, then insulation properties at 500°C (932°F) and steel properties at 300°C (572°F) may be used. Time steps should not exceed 5 s.

### **External Steelwork**

Temperature rise is proportional to the heat flux incident on the steel member and inversely proportional to the weight to perimeter ratio of the section.

### **Advanced calculation method**

A computer model is required that accounts for exposure conditions based on the design fire, and characterized by a heat flux, or a temperature time history, along with radiation and convection parameters. Temperature-dependent material properties are used to calculate temperature variation in time and space within the steel members and the insulation material.

### **Material properties at elevated temperatures**

Mechanical properties of steel with yield strength less than 448 MPa (65 ksi), defined at a yield strain of 2%, and of normal or light weight concrete with compressive strength less than 55 MPa (8000 psi) are given for temperatures up to 1200°C (2200°F). These properties (see Section 4.2.2) are adopted from Eurocode 3 (2010) and Eurocode 4 (2005) and therefore the yield stress is defined at 2% strain consistently with Eurocode.

### **Structural Design Requirements**

General structural integrity: The structural system should be able to sustain local damage due the design basis fire and maintain a stable continuous load path to the foundation. The structural frame should have adequate strength and deformation capacity to withstand the structural actions caused by the design basis fire, within prescribed limits of deformation. Connections should be able to develop the strength of the connected members in fire or resist the forces, moments and deformations obtained by analysis of the structure under the applicable load combinations that include the design basis fire:

$$(0.9 \text{ or } 1.2)D + T + 0.5L + 0.2S$$

where

$D$  = nominal dead load

$L$  = nominal occupancy live load

$S$  = nominal snow load

$T$  = nominal forces and deformations due to the design basis fire.

### **Advanced analysis**

An advanced analysis of the effects of the design basis fire on the structure includes a thermal and a mechanical analysis. The thermal analysis produces a temperature field in each structural element and should account for the presence of insulation. The mechanical analysis results in forces and deformations in the structural system subjected to the response calculated in the thermal analysis. The mechanical analysis should account for the temperature dependence of material properties, the effects of thermal expansion, large deformations, and possible changes in boundary conditions and connection fixity. All relevant limit states, such as excessive deflections, connection fractures, overall and local buckling should be considered.

### **Simple analysis**

A simple analysis that assumes the support and restraint conditions remain unchanged from normal temperatures is allowed for evaluating the performance of individual members during fire exposure. If temperatures are below 200°C (400°F) material properties may be assumed unchanged from normal temperatures.

### **Tension members**

The thermal response of a tension member may be calculated by a one-dimensional heat transfer equation with heat input determined from the design-basis fire. The design strength equations for normal temperatures may be used, with the mechanical steel properties changed to correspond to the maximum steel temperature assumed to apply uniformly over the entire cross section.

### **Compression members**

For the simple analysis, one dimensional heat transfer from the design-basis fire is permitted (temperature is uniform over the cross section and the length of the member). The nominal compressive strength for flexural buckling  $F_{cr}(T)$  is given by:

$$\frac{F_{cr}(T)}{F_y(T)} = 0.42^{\lambda(T)} \quad (A4.2)$$

$$\lambda(T) = \sqrt{\frac{F_y(T)}{F_e(T)}}$$

where  $F_y(T)$  = yield stress at temperature  $T$ ,  $F_e(T)$  = Euler buckling stress at temperature  $T$ , and the same equation number is given as in AISC 2011. This equation and others below come from the work of Takagi and Deierlein (2007). The 2005 AISC Specifications used the standard strength equations, such as E3.2 below, with the modulus of elasticity  $E$ , the yield strength  $F_y$  and the ultimate strength  $F_u$  reduced by appropriate factors due to elevated temperatures. Takagi and Deierlein (2007), however, showed that these equations are unconservative (Fig. 4.2), especially in the inelastic range, and the change in the shape of the stress-strain curve (more gradual yielding at elevated temperatures) needs to be taken into account in addition to the changes in  $E$ ,  $F_y$  and  $F_u$ . This suggestion was adopted in AISC 2011. Eq. A4.2 is similar, but not identical in form to the equation for inelastic flexural buckling under normal temperature:

$$\frac{F_{cr}}{F_y} = 0.658^{F_y/F_e} \quad \text{for} \quad \frac{F_y}{F_e} \leq 2.25 \quad (E3.2)$$

$$\frac{F_{cr}}{F_e} = 0.877 \quad \text{for} \quad \frac{F_y}{F_e} > 2.25$$

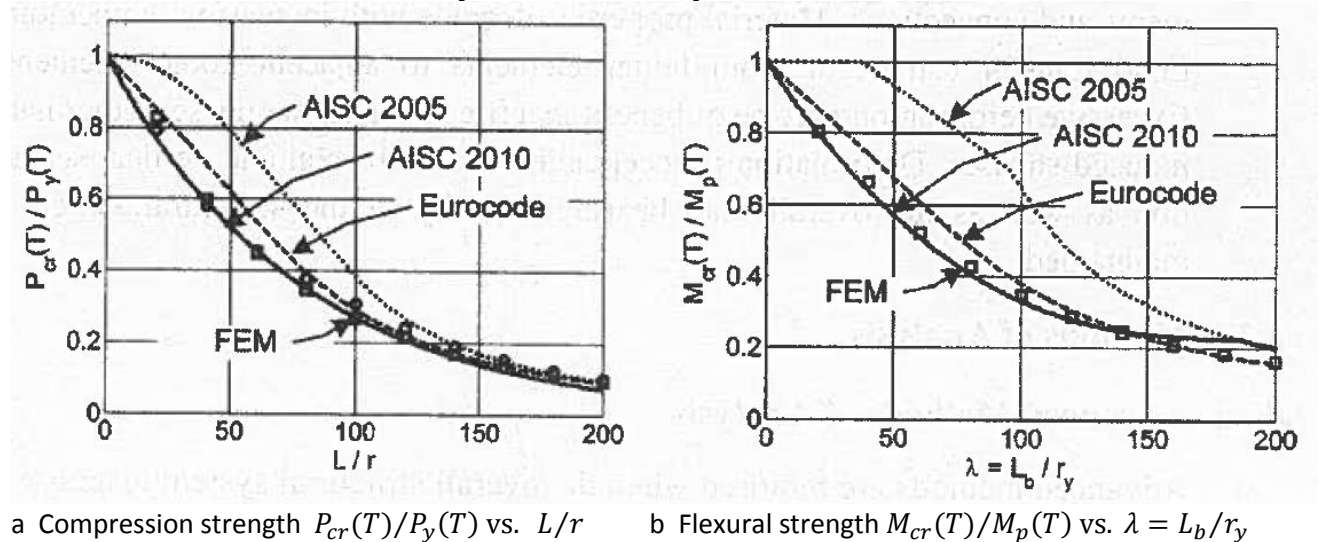

Figure 4.2 Comparison of compression and flexural strengths at 500 °C (932 °F)  
 Takagi and Deierlein (2007), AISC Construction Manual, Appendix 4 (2011)  
 Copyright 2011 American Institute of Steel Construction, reprinted with permission

Using the same notation as Eurocode:

$$\bar{\lambda}_0^2 = \frac{F_{y0}}{F_{e0}} \quad \bar{\lambda}^2(T) = \frac{F_y(T)}{F_e(T)}$$

$$F_{cr0} = 0.658\bar{\lambda}_0^2 F_{y0} \text{ for } \bar{\lambda}_0^2 \leq 2.25$$

$$F_{cr0} = 0.877F_{e0} \text{ for } \bar{\lambda}_0^2 > 2.25$$

$$F_{cr}(T) = 0.42\bar{\lambda}^{(T)} F_y(T)$$

### Flexural members

In general, the formulas used for flexural members at room temperature apply, with the proviso that material properties are now temperature dependent. Takagi and Deierlein (2007) have shown that this approach can be unconservative, and where their work applies, new formulas have been adopted for the lateral-torsional buckling of laterally unbraced doubly-symmetric members and channels bending about their major axis and having compact webs and flanges:

a) When  $L_b \leq L_r(T)$

$$M_n(T) = C_b \left[ M_r(T) + [M_p(T) - M_r(T)] \left[ 1 - \frac{L_b}{L_r(T)} \right]^{c_x} \right] \quad (A4.3)$$

b) When  $L_b > L_r(T)$

$$M_n(T) = F_{cr}(T) S_x \quad (A4.4)$$

where

$$F_{cr}(T) = \frac{C_b \pi^2 E(T)}{(L_b/r_{ts})^2} \sqrt{1 + 0.078 \frac{Jc}{S_x h_0} \left( \frac{L_b}{r_{ts}} \right)^2} \quad (A4.5)$$

$$L_r(T) = 1.95 r_{ts} \frac{E(T)}{F_L(T)} \sqrt{\frac{Jc}{S_x h_0} + \sqrt{\left( \frac{Jc}{S_x h_0} \right)^2 + 6.76 \left[ \frac{F_L(T)}{E(T)} \right]^2}} \quad (A4.6)$$

$$M_r(T) = S_x F_L(T) \quad (A4.7)$$

$$F_L(T) = F_y (k_p - 0.3k_y) \quad (A4.8)$$

$$M_p(T) = Z_x F_y(T) \quad (A4.9)$$

$$c_x = 0.53 + \frac{T}{450} \leq 3.0 \text{ where } T \text{ is in } ^\circ\text{F} \quad (A4.10)$$

$$c_x = 0.6 + \frac{T}{250} \leq 3.0 \text{ where } T \text{ is in } ^\circ\text{C} \quad (A4.10M)$$

$c = 1$  for doubly-symmetric I-sections;  $c = \frac{h_0}{2} \sqrt{\frac{I_y}{C_w}}$  for channels;

$C_b$  = lateral-torsional buckling modification factor for non-uniform moment diagram;

$C_w$  = warping constant;

$E$  = Young's modulus;

$F_{cr}$  = critical stress;

$F_L$  = magnitude of flexural stress in compression flange at which flange local buckling or lateral-torsional buckling is influenced by yielding;

$F_y$  = specified yield strength;

$h_0$  = distance between the flange centroids;

$I_y$  = out-of-plane moment of inertia;

$J$  = torsional constant;

$k_p = F_p(T)/F_y$  = ratio of proportional stress at  $T$  to specified yield strength at room temperature;

$k_y = F_y(T)/F_y$  = ratio of yield stress at  $T$  to specified yield strength at room temperature;

$L_b$  = distance between points that are braced against lateral displacement of the compression flange or braced against twist of the cross section;

$L_p$  = limiting laterally unbraced length for the limit state of yielding;  
 $L_r$  = limiting laterally unbraced length for the limit state of inelastic lateral torsional buckling;  
 $M_n$  = nominal flexural strength;  
 $M_p$  = plastic bending moment;  
 $M_r$  = elastic moment at onset of yielding;  
 $r_{ts}$  = effective radius of gyration;  $r_{ts}^2 = \frac{\sqrt{I_y C_w}}{S_x}$   
 $r_y$  = radius of gyration about y-axis;  
 $S_x$  = elastic section modulus about x-axis;  
 $T$  = temperature;  
 $Z_x$  = plastic section modulus about x-axis.

Compared to the AISC equations for room temperature (below), the above equations distinguish between only two regions of behavior (elastic and inelastic lateral-torsional buckling), instead of three (elastic, inelastic lateral-torsional buckling and full plastic bending). This is because, at elevated temperatures, the critical moment drops off quickly from the plastic moment at small slenderness values, and the full plastic bending region is no longer significant. In the calculation of  $L_r$  (Eqs. A4.6 and F2.6), the initial yield stress  $F_y$  is replaced by the proportional limit stress minus the residual stress estimated to be 30% of the yield strength. For comparison, the AISC equations for lateral-torsional buckling at room temperature are also shown below:

- a) When  $L_b \leq L_p$ , the limit state of lateral-torsional buckling does not apply. The limit state of yielding is:

$$M_n = M_p = F_y Z_x \quad (F2.1)$$

- b) When  $L_p < L_b \leq L_r$ ,

$$M_n = C_b \left[ M_p - (M_p - 0.7 F_y S_x) \left( \frac{L_b - L_p}{L_r - L_p} \right) \right] \leq M_p \quad (F2.2)$$

- c) When  $L_b > L_r$ ,

$$M_n = F_{cr} S_x \leq M_p \quad (F2.3)$$

where

$$F_{cr}(T) = \frac{C_b \pi^2 E}{\left( \frac{L_b}{r_{ts}} \right)^2} \sqrt{1 + 0.078 \frac{J_c}{S_x h_0} \left( \frac{L_b}{r_{ts}} \right)^2} \quad (F2.4)$$

$$L_p = 1.76 r_y \sqrt{\frac{E}{F_y}} \quad (F2.5)$$

$$L_r = 1.95 r_{ts} \frac{E}{0.7 F_y} \sqrt{\frac{J_c}{S_x h_0} + \sqrt{\left( \frac{J_c}{S_x h_0} \right)^2 + 6.76 \left[ \frac{0.7 F_y}{E} \right]^2}} \quad (F2.6)$$

$M_{p0}$  = plastic moment

$M_{r0}$  = initial yield moment (reduced to account for residual stresses)

$E_0, G_0$  = elastic moduli.

### Beam-column strength

AISC uses a bilinear combination of the ratio of axial and bending effects.

$$\text{For } \frac{P_u}{P_{cry,AISC(T)}} \geq 0.2, \quad \frac{P_u}{P_{cry,AISC(T)}} + \frac{8}{9} \frac{M_{ux}}{M_{crx,AISC(T)}} \leq 1.0 \quad (H1 - 1a)$$

$$\text{For } \frac{P_u}{P_{cry,AISC(T)}} < 0.2, \quad \frac{P_u}{2P_{cry,AISC(T)}} + \frac{M_{ux}}{M_{crx,AISC(T)}} \leq 1.0 \quad (H1 - 1b)$$

where

$P_u$  = factored axial load;

$M_{ux}$  = factored bending moment about strong axis;

$P_{cry,AISC(T)}$  = critical axial strength for flexural buckling about weak axis;

$M_{crx,AISC(T)}$  = critical bending moment for lateral-torsional buckling.

These equations are unchanged from previous editions, but  $P_{cry,AISC(T)}$  and  $M_{crx,AISC(T)}$  are now calculated by the new formulas above (Eq. A4.2 adapted for buckling about the weak axis, and Eq. A4.3 or A4.4).

### Design by qualification

AISC also allows prescriptive design in conformance with ASTM E119 and ASCE-SFPE 29-05 *Standard Calculation Method for Structural Fire Protection*. AISC notes that restrained conditions exist for floor and roof assemblies and individual beams when the surrounding members and connections can resist thermal expansion throughout the range of elevated temperatures.

## 4.2.4 Canadian Standards Association CSA S16-09 “Limit States Design of Steel Structures”

### Annex K: Structural design for fire conditions

The development (CISC Commentary 2010) of CSA S16-09 Annex K parallels that of AISC 2011 Appendix 4. In Canada until recently, the design of steel structures for fire conditions followed the standard design equations at normal temperature, but with material properties altered on account of elevated temperatures. Takagi and Deierlein (2009, Fig. 4.4) showed that this approach was unconservative and their work was instrumental in bringing about Annex K as part of the 2009 edition of CSA S16. The approach is similar to that of AISC and agrees well with Eurocode methods. The equations for design for fire apply for temperatures greater than 200°C and are consistent in form with (albeit more complicated than) their counterparts for ambient temperature.

### Calculation of temperatures in steel

#### Unprotected steel:

A first order analysis assumes uniform temperature over the member and typically uses lumped heat capacity analysis. The temperature rise  $\Delta T_s$  is:

$$\Delta T_s = \frac{a}{c_s(M/D)} (T_F - T_s) \Delta t$$

where

$a = a_c + a_r$  = heat transfer coefficient;

$a_c$  = convective heat transfer coefficient  $\cong 25 \text{ W}/(\text{m}^2 \cdot ^\circ\text{C})$ ;

$a_r$  = radiative heat transfer coefficient =  $\frac{5.67 \times 10^{-8} \epsilon_F}{T_F - T_s} (T_F^4 - T_s^4)$ ;

$c_s$  = steel heat capacity;

$\varepsilon_F$  = emissivity;

$M/D$  = ratio of steel mass per unit length to perimeter exposed to fire;

$T_F$  = fire temperature;

$T_s$  = steel temperature;

$\Delta t$  = time increment < 5 s.

For **protected steel** members, two cases are considered:

If the thermal capacity of the protection is negligible compared to that of steel, i.e.,

$$c_s M/D > 2 d_p \rho_p c_p$$

where

$d_p$  = thickness of protection,

$\rho_p$  = density of protection,

$c_p$  = thermal capacity of protection,

then the temperature rise of the steel member is:

$$\Delta T_s = \frac{k_p}{c_s d_p M/D} (T_F - T_s) \Delta t$$

where  $k_p$  = conductivity of protection.

If the thermal capacity of the protection needs to be considered, then the temperature rise is:

$$\Delta T_s = \frac{k_p}{d_p} \frac{T_F - T_s}{c_s M/D + d_p \rho_p c_p / 2} \Delta t$$

For **external steelwork**, the temperature rise is:

$$\Delta T_s = \frac{q''}{c_s M/D} \Delta t$$

Alternatively, a more advanced model can be used to calculate the temperature rise in the member.

The mechanical properties of steel at elevated temperatures are the same as in Eurocode.

Three levels of **structural design** are possible:

- a) Analysis of individual elements, accounting for reduction in resistance and stiffness with temperature, but ignoring the effects of restraint to thermal expansion and bowing;
- b) Analysis of substructures where the effects of restrained thermal expansion and thermal bowing are considered by incorporating geometric and material nonlinearities;
- c) Global analysis where restrained thermal expansion, thermal bowing, material degradation and geometric nonlinearity are considered.

### CSA S-16 column strength at high temperatures

$$P_{cr}(T) = [1 + \lambda(T)^{2dn}]^{-1/(dn)} A F_y(T)$$

where

$$\lambda(T) = \sqrt{\frac{F_y(T)}{F_e(T)}} = \frac{KL}{r} \sqrt{\frac{F_y(T)}{\pi^2 E(T)}}$$

$\lambda(T)$  = column slenderness ratio;

$A$  = column cross section area;

$d = 0.6$  ;  
 $F_e(T)$  = Euler buckling load at temperature  $T$  ;  
 $F_y(T)$  = yield strength at temperature  $T$  ;  
 $KL$  = column effective length ;  
 $n$  as given for nominal strength (below) ;  
 $P_{cr}(T)$  = column strength at temperature  $T$  ;  
 $r$  = radius of gyration of column cross section.

**CSA S-16 column strength at ambient temperature**

$$P_{cr0} = [1 + \lambda^{2n}]^{-1/n} A F_{y0}$$

where

$$\lambda = \sqrt{\frac{F_{y0}}{F_{e0}}} = \frac{KL}{r} \sqrt{\frac{F_{y0}}{\pi^2 E_0}}$$

subscript 0 is for ambient temperature ;

$n = 1.34$  for hot-rolled, fabricated structural sections, and hollow structural sections ;

$n = 2.24$  for doubly symmetric welded three-plate members with flange edges oxy-flame-cut, and hollow structural sections.

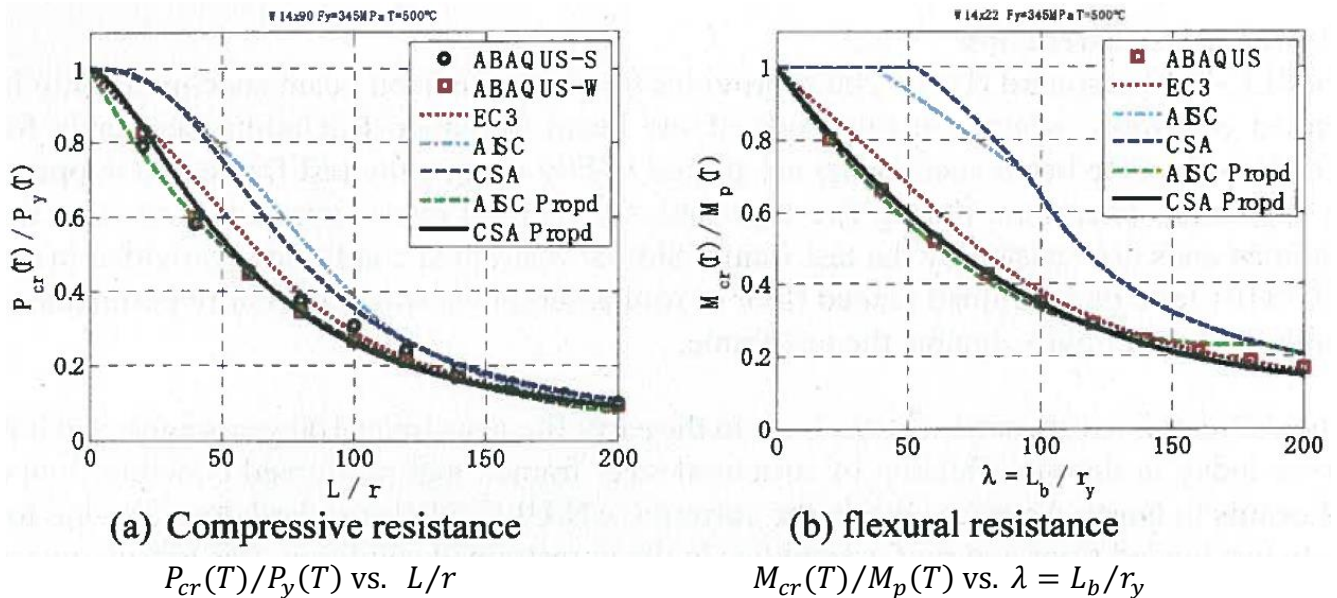

Figure 4.3 Comparison of compression and flexural strengths at 500°C (932°F) (S and W stand for strong and weak axis buckling strength respectively) - Takagi and Deierlein (2009), Frater (2010) Copyright 2009 Canadian Steel Construction Council, reprinted with permission

Fig. 4.3a compares various column strength curves, AISC 2005, CSA S16-01 (reprinted 2005), AISC proposed (adopted as Appendix 4 in 2010), CSA proposed (adopted as Annex K in 2009), Eurocode (2003) with finite-element (FE) simulations of a wide flange column (W 14 x 90 Gr. 50 or W 360 x 134,  $F_y = 345$  MPa) buckling about the strong (S) or weak axis (W). The new AISC and CSA curves are in much closer agreement with Eurocode and FE results, compared with the old curves, which were unconservative, especially in the inelastic range.

### CSA S-16 beam strength at high temperatures

$$M_{cr}(T) = C_K M_p(T) + (1 - C_K) M_p(T) \left[ 1 - \left( \frac{C_K M_p(T)}{M_u(T)} \right)^{0.5} \right]^{C_z(T)}$$

where

$C_K = 0.12$ ;

$M_{cr}(T)$  = nominal beam strength at temperature  $T$ ;

$M_p(T)$  = plastic moment using  $F_y(T)$ ;

$M_u(T)$  = elastic critical moment at temperature  $T$ ;

$T$  = temperature °C;

$$M_u(T) = \frac{\omega_2 \pi}{L} \sqrt{E(T) I_y G(T) J + I_y C_w \left( \frac{\pi E(T)}{L} \right)^2}$$

$\omega_2$  = moment gradient, same as for ambient temperature (see below);

$C_w$  = warping constant;

$E$  = Young's modulus;

$G$  = shear modulus;

$I_y$  = out-of-plane moment of inertia;

$J$  = torsional constant;

$L$  = length of unbraced portion of beam; and

$$C_z(T) = \frac{T + 800}{500} \leq 2.4$$

### CSA S-16 beam strength at ambient temperature

$$\text{For } M_{u0} > 0.67 M_{p0} \quad M_{cr0} = 1.15 M_{p0} \left( 1 - \frac{0.28 M_{p0}}{M_u} \right) \leq M_{p0}$$

$$\text{For } M_{u0} \leq 0.67 M_{p0} \quad M_{cr0} = M_{u0}$$

where

$$M_{u0} = \frac{\omega_2 \pi}{L} \sqrt{E_0 I_y G_0 J + I_y C_w \left( \frac{\pi E_0}{L} \right)^2}$$

$\omega_2$  = moment gradient;

$\omega_2 = 1.75 + 1.05\kappa + 0.3\kappa^2 \leq 2.5$  for unbraced lengths subject to end moments;

$\omega_2 = 1.0$  when the bending moment at any point within the unbraced length is larger than the larger end moment or when there is no effective lateral support for the compression flange at one of the ends of the unsupported length;

$\kappa$  = the ratio of the smaller factored moment to the larger factored moment at opposite ends of the unbraced length, positive for double curvature and negative for single curvature.

Fig. 4.3b compares various beam strength curves, AISC 2005, CSA S16-01 (reprinted 2005), AISC proposed (adopted as Appendix 4 in 2010), CSA proposed (adopted as Annex K in 2009), Eurocode (2003) with finite-element (FE) simulations of a wide flange beam (W 14 x 22 Gr. 50 or W 360 x 32.9,  $F_y = 345$  MPa) buckling in torsional-flexural mode about the strong (S) or weak axis (W). The new AISC and CSA curves are in much closer agreement with Eurocode and FE results, compared with the old curve, which were unconservative, especially in the inelastic range.

The factored resistance is obtained by multiplying the nominal resistance with the same resistance factor  $\phi$  as for ambient temperature. Qualification testing is an acceptable alternative to design by analysis for providing fire resistance.

#### 4.2.5 New Zealand and Australia

**NZS 3404: Part 1:1997 (with Oct. 2007 amendment) Steel Structures Standard** current in Jan. 2013, Chapter 11 “Fire”

**Australian Standards AS 4100-1998 Steel Structures** - Section 12 Fire

These standards cover steel building elements required to have a fire resistance rating (FRR for New Zealand, fire-resistance level FRL for Australia), i.e., a period of structural adequacy (PSA) under a standard fire exposure. The FRR or FRL depends on the thickness of protection for protected members, and the section factor for unprotected members. The section factor (SF) is defined as either the ratio of the surface area exposed to fire to the mass of steel, or the ratio of the heated perimeter to the cross section area. The PSA may be calculated as the duration from the start of the fire test to the time when the steel temperature reaches a limiting value  $T_l$ . It may also be determined by tests or by structural analysis accounting for the effects of temperature on material properties. The variation of the yield strength and modulus of elasticity of steel vs. temperature is given as follows (Fig. 4.4, AS 4100-1998):

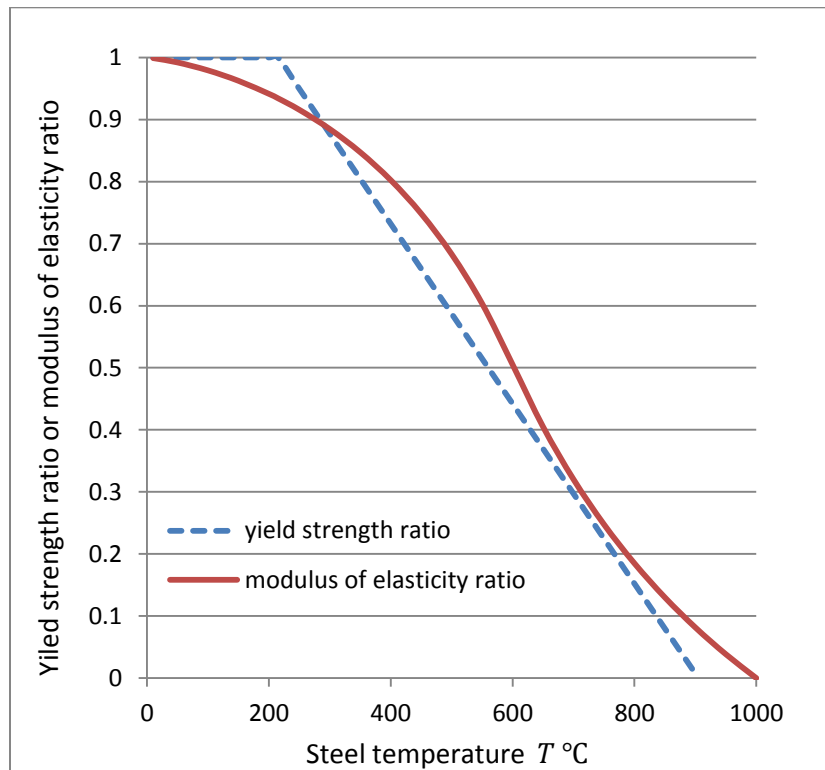

Figure 4.4 Variation of mechanical properties of steel with temperature, adapted from AS 4100-1998

$$\text{Yield strength ratio} = k_{y,T} = \frac{905-T}{690} \leq 1.0 \quad \text{for } 215^\circ\text{C} < T \leq 905^\circ\text{C}$$

Young's modulus at elevated temperatures is defined by the ratio  $k_{E,T}$ :

$$k_{E,T} = 1.0 + \frac{T}{2000 \ln(T/1100)} \quad \text{for } 0 < T \leq 600 \text{ }^\circ\text{C}$$

$$k_{E,T} = \frac{690 [1 - (T/1000)]}{T - 53.5} \quad \text{for } 600 < T \leq 1000 \text{ }^\circ\text{C}$$

According to AS 4100 and NZS 3404, a steel member is expected to yield at a limiting temperature which accounts for the ratio of the load in fire to the *capacity at ambient temperature* (load ratio  $r$ ). (In contrast, the Eurocode degree of utilization  $\mu_0$  is the ratio of the design effect of actions for the fire situation to the corresponding *design resistance in the fire situation*). From the definition of the yield strength, the limiting temperature =  $T_l = 905 - 690 r$ .

The resistance time of protected and unprotected steel against a standard fire is given by the same formulas used in the Design Manual on the European Recommendations for Fire Safety of Steel Structures (European Convention for Constructional Steelwork, Brussels, Belgium, 1985).

For unprotected members, formulas for the time  $t$  in minutes at which the limiting temperature  $T_l$  is attained is given for members exposed on three or four sides:

$$t = -5.2 + 0.0221 T_l + 0.433 T_l/SF \quad \text{for three-sided exposure,}$$

$$t = -4.7 + 0.0263 T_l + 0.213 T_l/SF \quad \text{for four-sided exposure,}$$

$$SF = k_{sm} = \text{ratio of exposed area to mass, } 2 \text{ m}^2/\text{tonne} \leq k_{sm} \leq 35 \text{ m}^2/\text{tonne, or}$$

$$SF = \frac{H_p}{7.85A} = \text{ratio of exposed perimeter to area, } 15 \text{ m}^{-1} \leq H_p/A \leq 275 \text{ m}^{-1}$$

For protected members, the time to reach the limiting temperature  $T_l$  is determined by tests. Connections to protected members should be protected with the maximum thickness required for any of the members. Connections to unprotected members are designed using the limiting temperature and the section factor of the connection components. They should achieve the same or lower load ratio as the members being connected.

#### 4.2.6 The Building Standard Law of Japan August 2011 - Steel

##### Calculation of critical time to failure of structural steel elements

The procedure starts with calculation of structural stresses under normal temperature. Next, the critical steel temperature is determined for various possible failure modes. The steel temperature rise is then computed for the cross section geometry and insulation that apply. Finally the time to critical condition is obtained and compared with the fire duration.

The **decrease of yield strength of steel with temperature** is governed by:

$$\kappa(T) = \frac{\sigma_y(T)}{F} = \frac{700 - T}{375} \quad \text{for } T > 325^\circ\text{C}$$

where

$F$  = nominal yield strength (at 1% strain) at normal temperature;

$T$  = temperature  $^\circ\text{C}$  ;

$\sigma_y(T)$  = yield strength at temperature  $T$ .

##### Steel Columns

The critical member temperature  $T_{cr}$  is governed by overall buckling, local buckling, thermal deformation, and allowable temperature (Notification 1433 p. 101).

$$T_{cr} = \min(T_B, T_{LB}, T_{DP}, 550^\circ\text{C})$$

where

$T_B$  = maximum temperature for overall buckling of steel columns;

$T_{LB}$  = maximum temperature for local buckling of steel columns;

$T_{DP}$  = maximum temperature for thermal deformation of steel columns.

550°C is the critical temperature of joints.

### Overall buckling of steel columns

The slenderness ratio  $\lambda$  is defined as:

$$\lambda = \sqrt{\frac{F}{\sigma_E}} = \frac{l_e}{\pi i} \sqrt{\frac{F}{E}}$$

where

$E$  = modulus of elasticity at normal temperature;

$l_e$  = effective column length;

$i$  = minimum radius of gyration;

$\sigma_E$  = Euler buckling stress.

The axial stress for overall buckling  $\sigma_B$  is similar to that for normal temperature (Harada 2004):

$$\frac{\sigma_B}{F} = \frac{1 - 0.24\lambda^2}{1 + 0.267\lambda^2}$$

From  $\sigma_B$ ,  $T_B$  can be calculated:

for  $\lambda < 0.1$ ,  $T_B$  is governed by yielding;

for  $0.1 \leq \lambda < 1$ ,  $T_B = \max \{\text{tangent modulus value, inelastic buckling value}\}$ . More precisely,

$$\text{for } \lambda < 0.1, \quad T_B = 700 - 375 p$$

$$\text{for } 0.1 \leq \lambda < 1, T_B = \max \left\{ 700 - 375p - 55.8(p + 30p^2)(\lambda - 0.1), 500 \sqrt{1 - \frac{p(1 + 0.267\lambda^2)}{1 - 0.24\lambda^2}} \right\}$$

where

$p$  = ratio of axial force  $P$  to column capacity at normal temperature =  $\frac{P}{FA_c}$

$A_c$  = column cross section area.

### Local buckling of steel columns

$$T_{LB} = 700 - \frac{375}{\min(R_{LBO}, 0.75)}$$

where  $R_{LBO}$  is a reduction factor that depends on the width or diameter to thickness ratio and is tabulated for H-, hollow square and cylindrical sections.

### Deformations of steel columns

$$T_{DP} = 20 + 18000/\sqrt{S}$$

where  $S$  = floor area of room that column faces ( $m^2$ ) and  $T_{DP}$  is in  $^{\circ}C$ . For example, for a very large room  $S = 1000 m^2$ ,  $T_{DP} = 589 ^{\circ}C$ . See explanation below for deformations of steel beams.

### Steel beams

Consider a steel beam of span  $2l$  with fixed ends under uniformly distributed load  $w$ . At bending failure, plastic hinges that develop plastic bending moment  $M_{pB}$  form at the ends and midspan:

$$w (2l)^2/8 = 2 M_{pB} \Leftrightarrow wl^2 = 4 M_{pB}$$

The critical temperature for flexural failure of steel beams is therefore:

$$T_{Bcr} = 700 - 375 wl^2/(4 M_{pB})$$

Notification 1433 p. 109 covers a more general case for the critical beam temperature  $T_{cr}$ .

$$T_{cr} = \min (T_{Bcr}, T_{DP}, 550^{\circ}C)$$

$$T_{Bcr} = 700 - \frac{750l^2(w_1 + w_2)}{M_{pB}(\sqrt{R_{B1} + R_{B3}} + \sqrt{R_{B2} + R_{B3}})^2}$$

where

$T_{Bcr}$  = critical temperature for flexural failure of steel beam;

$2l$  = beam span;

$w_1$  = uniformly distributed load;

$w_2$  = uniformly distributed load equivalent to concentrated loads;

$M_{pB} = FZ_{pBx}/1000$  = normal temperature plastic moment N/m;

$F$  = specified design yield strength  $N/mm^2$  ;

$Z_{pBx}, Z_{pBy}$  = plastic section modulus about strong, weak axis  $mm^3$  ;

$R_{B1}, R_{B2} = 1$  for fixed ends, 0 otherwise;

$R_{B3} = 1$  when top of beam is rigidly connected to slab,  $R_{B3} = Z_{pBy}/Z_{pBx}$  otherwise.

### Deformations of steel beams

$$T_{DP} = 20 + 18000/\sqrt{S}$$

where  $S$  = floor area of room that beam faces ( $m^2$ ) and  $T_{DP}$  is in  $^{\circ}C$ .

The following explanation is adapted from Harada (2004):

Take a steel frame under fire where all the beams are heated to  $T_{DP}$ . The beam length can be taken as  $\sqrt{S}$ , so the beam thermal elongation is  $\Delta l = 1.2 \times 10^{-5}(T_{DP} - T_0)\sqrt{S}$ , where  $T_0$  is the normal temperature and  $1.2 \times 10^{-5}/^{\circ}C$  is the coefficient of thermal expansion of steel. If the story drift is limited to  $\Delta l/4.32 = 1/20$ , where a story height of 4.32 m is assumed, then

$$T_{DP} = T_0 + \frac{4.32}{20} \frac{1}{1.2 \times 10^{-5}\sqrt{S}} = 20 + \frac{18000}{\sqrt{S}}$$

### Connections

The critical temperature for steel connections is  $550^{\circ}C$ .

### Retained fire-resistance time of protected steel beams and columns

From  $T_{cr}$ , the retained fire-resistance time  $t_{fr}$  of protected steel columns against enclosure fire, in minutes, can be calculated from formulas that take into account (Notification 1433 p. 100, 102, 108, 110):

- the properties of the insulating material, such as cross sectional area  $A_i$ , heated perimeter  $H_i$ , thermal resistance and heat capacity;
- the properties of the steel member, such as cross sectional area  $A_s$  and heated perimeter  $H_s$ ;
- the fire exposure, such as the fire temperature rise coefficient  $\alpha$ , the temperature rise delay time coefficient  $a_w$  (due to insulation), and the member temperature rise coefficient  $h$  (which depends on the steel cross section geometry).

$$t_{fr} = \max \left[ \frac{9866}{\alpha^{3/2}} \left\{ \frac{2}{h} \left\{ \frac{1}{\ln\{h^{16} (T_{cr} - 20)/1250\}} \right\} + \frac{a_w}{(H_i/A_i)^2} \right\}, \left( \frac{T_{cr} - 20}{\alpha} \right)^6 \right]$$

The member temperature rise coefficient  $h$  is:

$$h = \frac{\phi K_0 (H_s/A_s)}{\left\{ 1 + \frac{\phi R}{H_i/A_i} \right\} \left\{ 1 + \frac{\phi C (H_s/A_s)}{2(H_i/A_i)} \right\}}$$

$\phi = H_i/H_s$  = ratio of heated perimeters of insulation to steel section;

$K_0$  = basic temperature rise rate (tabulated);

$R$  = thermal resistance coefficient (depends on insulation and steel shape);

$C$  = heat capacity ratio (depends on insulation).

$a_w$ ,  $K_0$  and  $R$  are determined from heating tests of insulated steel members. The term  $\frac{a_w}{(H_i/A_i)^2}$  is the delay in temperature rise due to evaporation of water in the insulation.

### 4.3 Critical assessment

Much progress has been achieved in the last decade or so in moving beyond prescriptive methods that ensure a certain fire resistance rating by specifying minimum protection thickness or section dimensions. New performance-based methods allow the designer greater flexibility by providing guidance for calculating the temperature of members exposed to more realistic fires based on physical parameters, and more accurate determination of member temperature, stiffness and strength. The work of Takagi and Deierlein (2007, 2009) has been instrumental in improving the standards for fire design of steel structures in the USA and Canada, and making the prediction of behavior as close to computer simulation and experimental results as Eurocode is, while maintaining consistency of formulation with design equations at ambient temperature.

AISC has a simple method, where boundary conditions are assumed unchanged from ambient temperature conditions, and an advanced method, that accounts for thermal expansion and changes in end conditions. In comparison, Eurocode offers the designer three methods of calculations, the intermediate one being an analysis of a part of the structure, wherein the boundaries of the part of the structure are unchanged from ambient, but within the part of the structure, thermal expansion and changes in boundary conditions and material properties are accounted for. Two additional things

Eurocode has, but AISC does not, are guidance on connections in fire, and the temperature method. The latter is an alternative to the capacity method, whereby verification is carried out in the temperature domain, assuming a uniform temperature distribution and an utilization factor. The Japanese Building Standard Law has a simple limit formula for the deformation of beams and columns under fire, which AISC does not have.

### **Connections**

Several codes contain prescriptive methods to ensure the strength of steel connections in fire, such as limiting the temperature in steel connections to 550°C (Japan), protecting connections with the maximum insulation thickness required for any of the connected members (New Zealand), or limiting the utilization of connections to not exceed that of the connected members (Eurocode, New Zealand). (At 550°C steel retains about 60 % of its yield strength  $F_y$  at ambient temperature and allowable stress design commonly uses  $0.60 F_y$  as a limit.) In the Eurocode, the temperature of a joint may be calculated from the ratio of exposed area to volume of the connected members in the vicinity of the joint, or from the temperature of the bottom flange at midspan. Eurocode 3-1.8:2005 states that the fire resistance of a bolted or welded connection may be assumed to be sufficient if the fire protection on the connection is as effective on the joint as it is on the members, and the utilization of the joint is less than or equal to the maximum utilization of any of the connected members. In contrast, AISC 2011 14<sup>th</sup> Ed. Construction Manual Appendix 4 *Structural Design for Fire Conditions* presents only general structural integrity requirements for connections.

It is recommended that US performance code provisions for steel connections in fire be developed beyond the present general structural integrity requirements. This development is particularly needed because elevated temperatures may cause new load paths to develop (e.g., development of tensile membrane action), and thermal expansion may cause gaps to close, thus potentially developing tension or compression in a connection, where none existed at ambient temperature. One promising approach is to extend to elevated temperatures the component method used in Eurocode 3-1.8:2005, whereby a joint is modeled as an assembly of rigid links and extensional springs, whose load-deformation curves represent different joint components that can be summed to represent the total joint response. The joint components may include tension, compression and shear zones. The tension zone may include bolts, column web, beam web in tension, column flange and end plate in bending; the compression zone may include beam flange, beam web, and column web; and the shear zone may include beam and column web panels and bolts.

Research on connection behavior at elevated temperatures includes work by Da Silva et al. (2001), who used the ratios of strength to stiffness of various joint components and modified them to account for temperature effects by considering the sequence of yield of the components; and by Kirby (1995), who observed thread stripping in bolts tested between 530°C and 740°C. Recent finite-element calculations by Franssen (2004) showed that temperatures in joints are higher than predicted by Eurocode 3-1.2:2005 (although still lower than in the connected members) because the dimensions of joint components are an order of magnitude smaller than those of the connected members, and the influence of the connected members can be felt in the joint. There is a need for a systematic study of the performance of connections in fire in order to move beyond prescriptive methods.

### **Stress-strain curves**

Takagi and Deierlein (2007, 2009) have shown the importance of using the complete stress-strain curve of steel at elevated temperatures, rather than just accounting for the influence of temperature on the yield strength and modulus of elasticity. It is recommended that better steel stress-strain relationships

at elevated temperature be incorporated in future US performance building codes. Recent work at NIST is a step in that direction (Luecke et al. 2011):

$$\text{for } \varepsilon < S_y/E \quad \sigma = E\varepsilon$$

$$\text{for } \varepsilon \geq S_y/E \quad \sigma = \left[ RS_y^0 + (k_3 - k_4 S_y^0) \exp\left(-\left(\frac{T}{k_2}\right)^{k_1}\right) \left(\varepsilon - \frac{RS_y^0}{E}\right)^n \right] \left(\frac{\dot{\varepsilon}}{\dot{\varepsilon}_0}\right)^m$$

where

$$E = E_0 + e_1 T + e_2 T^2 + e_3 T^3$$

$$R = \exp\left[-\frac{1}{2}\left(\frac{T^*}{r_3}\right)^{r_1} - \frac{1}{2}\left(\frac{T^*}{r_4}\right)^{r_2}\right]$$

$$m = m_0 + m_3 \left[1 - \exp\left(-\left(\frac{T}{m_2}\right)^{m_1}\right)\right]$$

$\varepsilon = \ln(l/l_0) =$  true strain

= natural log of current length over original length;

$\dot{\varepsilon}$  = true strain rate;

$\dot{\varepsilon}_0$  = reference true strain rate =  $8.333 \times 10^{-5} \text{s}^{-1}$  in ASTM E8;

$\sigma$  = true stress = force / current area;

$E$  = modulus of elasticity;

$E_0$  = modulus of elasticity at room temperature;

$R$  = retained strength, usually  $S_y/S_y^0$ ;

$S_y$  = measured yield strength;

$S_y^0$  = measured yield strength at room temperature;

$T$  = temperature °C;

$T^* = T - 20$ ;

$e_1, e_2, e_3$  = curve-fitting empirical constants;

$k_1, k_2, k_3, k_4$  = curve-fitting empirical constants;

$m$  = strain rate sensitivity parameter;

$m_0, m_1, m_2, m_3$  = curve-fitting empirical constants;

$n$  = strain-hardening exponent;

$r_1, r_2, r_3, r_4$  = curve-fitting empirical constants.

An updated version of this model has been submitted to the AISC Engineering Journal for publication (Luecke et al. 2013).

Parameter	Value
$r_1$	5.708
$r_2$	1.000
$r_3$	590°C
$r_4$	919°C
$k_1$	8.294
$k_2$	538°C
$k_3$	959 MPa
$k_4$	0.766
$n$	0.483
$m_0$	0.0108
$m_1$	7.308
$m_2$	613°C
$m_3$	0.126
$\dot{\varepsilon}_0$	$8.333 \times 10^{-5} \text{s}^{-1}$
$E_0$	206.0 GPa
$e_1$	$-4.326 \times 10^{-2} \text{GPa}/^\circ\text{C}$
$e_2$	$-3.502 \times 10^{-5} \text{GPa}/^\circ\text{C}^2$
$e_3$	$-6.592 \times 10^{-8} \text{GPa}/^\circ\text{C}^3$

Unlike the Eurocode 3 formulation, the NIST model explicitly describes the time-dependent nature of the strength of steel at high temperature. For untested steels, it predicts the stress-strain behavior using only the measured room-temperature yield strength,  $S_y$ . On a subset of eight steels, the model predicts the stress-strain behavior slightly better than the equally complicated Eurocode 3 model. For three structural steels from the literature and not used in the development of the model, the NIST constitutive relations and the Eurocode 3 model predict stress-strain behavior with similar quality.

### **Plate buckling**

Compared with ambient temperature, the stress-strain curve of steel at elevated temperatures deviates from linearity at lower strains (see Appendix at the end of this chapter). This leads to lower plate buckling strength than the ultimate buckling load determined by equating the plate edge stress with yield stress (defined at 2% strain). Selamet and Garlock (2013) have shown that the direct mapping from ambient to elevated temperatures of the current equations for plate buckling strength can lead to unconservative predictions. Earlier criticisms by Takagi and Deierlein (2007, 2009) of the unconservativeness of this direct mapping in wide-flange sections led to changes in US and Canadian steel design specifications for compression and flexural members. It is recommended that the equations for plate buckling strength at elevated temperatures be updated, and a critical assessment be made of the possible need to revise other design equations due to the change in shape of the stress-strain curve at elevated temperatures. The adoption of a new stress-strain formulation similar to NIST proposal would be an additional reason to update steel design equations for fire.

### **Effects of temperature gradient**

Many of the simple design equations in US building codes assume a uniform temperature over the entire cross section, or even over the entire length of a member. When the temperature is not uniform, stresses redistribute from the hot parts of the cross section to the cooler parts. As the temperature increases, the hotter parts of the section reach their limiting temperature, yield plastically, and transfer load to cooler regions, which still behave elastically. This load transfer continues until the cool regions become plastic and the member fails. It is recommended that building codes account for temperature gradients where necessary with the aid of design equations, without requiring designers to perform a detailed finite-element analysis.

Eurocode accounts for a temperature gradient along the beam depth for the purpose of evaluating the strength of joints. In a recent paper, Agarwal et al. (2014) proposed design equations for steel columns exposed to uneven heating by addressing additional limit states. They noted that thermal gradients in a column cross section can reduce the load carrying capacity for two reasons: column deformations due to uneven thermal expansion (bowing) and asymmetry in the column cross section due to uneven degradation of material properties (yield stress and elastic modulus).

## **References**

American Institute of Steel Construction Steel (2011) *"AISC Construction Manual, Appendix 4: Structural Design for Fire Conditions,"* 14<sup>th</sup> Ed., AISC, Chicago, IL, USA

American Society of Civil Engineers (2007) *"ASCE/SEI/SFPE 29-05 Standard Calculation Methods for Structural Fire Protection,"* Reston, VA, USA

Canadian Institute of Steel Construction (2010) *"Commentary on CSA S16-09 Annex K: Structural design for Fire conditions,"* CISC, Markham, Ontario, Canada

Building Center of Japan (2011) *"The Building Standard Law of Japan,"* Tokyo, Japan

Eurocode 3: Design of steel structures- Part 1-2: General rules - structural fire design, BS EN 1993-1-2:2005 also DIN EN 1993-1-2:2010-12, CEN, Brussels, Belgium

Eurocode 4: Design of composite steel and concrete structures- Part 1-2: General rules - structural fire design, DIN EN 1994-1-2:2010-12, EN 1994-1-2:2005 + AC:2008, CEN, Brussels, Belgium

European Convention for Constructional Steelwork (1985) *“Design Manual on the European Recommendations for Fire Safety of Steel Structures,”* Brussels, Belgium

International Code Council (2012) *“International Building Code”* Country Club Hills, IL, USA

Franssen, M. (2004) “Numerical determination of 3D temperature fields in steel joints,” *Fire and Materials*, **28**, 63-82

Frater, G. (2010) “CIST Commentary on CSA S19-09 Annex K Structural Design for Fire Conditions,” Canadian Institute of Steel Construction, Markham, Ont., Canada

Harada, K., Ohmiya, Y., Natori, A., Nakamichi, A. (2004) “Technical basis on structural fire resistance design in building standards law of Japan” *Fire and Materials*, 28:323-341 DOI:10.1002/fam.857

Lane, B. (2008) “Approaches to calculating structural fire resistance,” *NFPA Fire Protection Handbook*, 12<sup>th</sup> ed., Vol. II, Chap. 19.5, Cote, A.E. Ed. National Fire Protection Association, Quincy, MA, USA pp. 19.77-19.126

Luecke, W., Banovic, S.W., and McColskey, J.D. (2011) “High-temperature tensile constitutive data and models for structural steels in fire,” NIST Technical Note 1714, National Institute of Standards and Technology, Gaithersburg, MD 20899

Luecke, W. E., Gross, J. L., and McColskey, J. D. (2013) “High-temperature, tensile, constitutive models for structural steel in fire,” submitted to *AISC Engineering Journal*, AISC, Chicago, IL, USA

National Research Council Canada (2010) *“National Building Code of Canada 2010”* (NBCC), Institute of Research in Construction, Ottawa, ON, Canada, Vol. 2 Appendix D: Fire-performance Ratings

Selamet, S. and Garlock, M. (2013). "Plate Buckling Strength of Steel Wide-Flange Sections at Elevated Temperatures." *ASCE J. Struct. Eng.*, 139 (11), 1853-1865, online 3 Nov 2012  
[http://dx.doi.org/10.1061/\(ASCE\)ST.1943-541X.0000769](http://dx.doi.org/10.1061/(ASCE)ST.1943-541X.0000769)

Standards Australia (1998) “Steel structures,” AS 4100-1998, Section 12: Fire, Homebush, NSW, Australia

Standards New Zealand (1997) “Steel structures standard,” NZS 3404:Part 1:1997, Wellington, NZ (current in 2013) Chapter 11: Fire

Takagi, J. and Deierlein, G.G. (2007) “Strength design criteria for steel members at elevated temperatures,” *Journal of Constructional Steel Research*, Elsevier, 63, 1036–1050

Takagi, J. and Deierlein, G.G. (2009) “Proposed design equations for CAN/CSA S16 Appendix K Provisions for steel members at high temperatures,” Report prepared for the Canadian Institute of Steel Construction, Jan. 22

Wickstrom, U. (2008) "Methods for predicting temperatures in fire-exposed structures," SFPE Fire Protection Engineering, 4<sup>th</sup> ed. Chapter 4.9, Society of Fire Protection Engineers, Bethesda, MD. USA

### Appendix: 2% yield strain and 0.2% proof strain

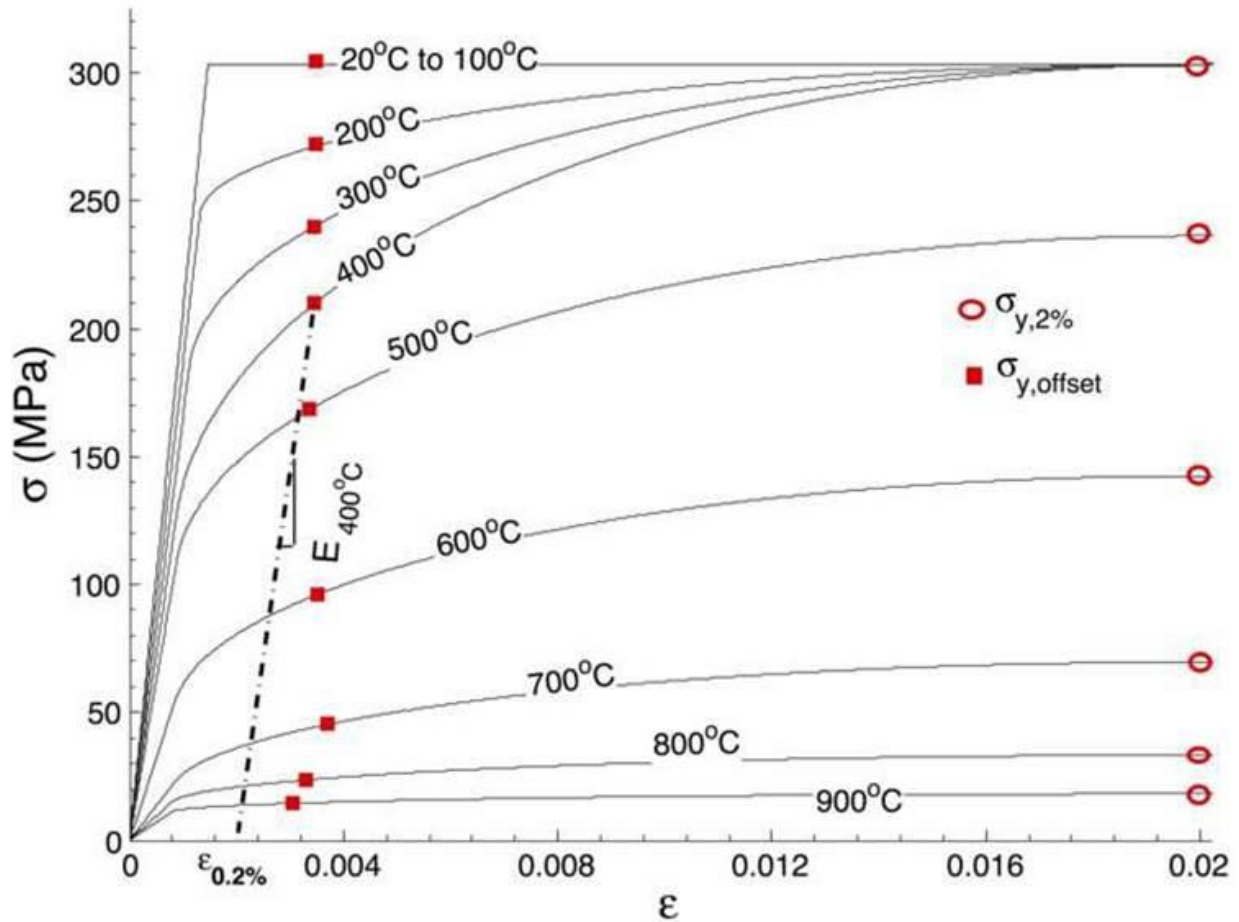

Figure 4.5: Eurocode (CEN 2001) stress-strain curves of steel at elevated temperatures from 100°C to 900°C with yield stresses:  $\sigma_{y,2\%}$  (red hollow circles, 2% strain) and  $\sigma_{y,offset}$  (red squares, 0.2% proof or plastic strain). From Selamet and Garlock (2013). Copyright 2013 American Society of Civil Engineers, reprinted with permission

# Chapter 5 Reinforced Concrete Structures

The simplest and most common method for the fire design of reinforced concrete (RC) members is to ensure that sections have the required thickness, and reinforcement the required cover. In addition, well detailed reinforcement with adequate tying enables moment redistribution, and axial restraint allows arch/membrane action to occur in fire events.

## 5.1 Calculation methods for concrete in USA

Building codes for concrete structures in the US differentiate between aggregate types, with carbonate concrete having better spalling resistance to fire than siliceous concrete. Member size and cover thickness are given for restrained or unrestrained beams and slabs, for prestressed or passively reinforced members. Continuous unrestrained members have longer fire endurance than simply supported members because they can redistribute moments, resulting eventually in failure of negative reinforcement over the supports. In concrete design for ambient conditions, the amount of negative reinforcement is limited to avoid compressive, brittle failure of the member.

### 5.1.1 ASCE/SEI/SPFE 29-05 Standard Calculation Methods for Structural Fire Protection

This standard provides methods to calculate the equivalent fire resistance, in terms of hours, of concrete, timber, masonry and steel members that would be achieved under the standard ASTM E119 (2012) fire test. It does not provide any guidance about the structural performance of members or structures under fire. The guidelines apply to concrete with specified compressive strength less than 10 000 psi or 69 MPa.

**Walls:** The minimum equivalent thickness to provide equivalent fire resistance of one to four hours is given for load bearing and non-bearing walls of different types of plain and reinforced concrete. Joints between precast concrete wall panels must be insulated and guidance is also given about the thickness required for different types of insulation.

**Floor and roof slabs:** The minimum equivalent thickness to provide equivalent fire resistance of one to four hours is given.

**Table 5.1 Fire resistance of concrete walls, floors and roofs**

Concrete Aggregate Type	Minimum Equivalent Thickness for Fire Resistance Rating (h)									
	1 h		1.5 h		2 h		3 h		4 h	
	in.	mm	in.	mm	in.	mm	in.	mm	in.	mm
Siliceous	3.5	89	4.3	109	5.0	127	6.2	157	7.0	178
Carbonate	3.2	81	4.0	102	4.6	117	5.7	145	6.6	168
Sand-lightweight	2.7	69	3.3	84	3.8	97	4.6	117	5.4	137
Lightweight	2.5	64	3.1	79	3.6	91	4.4	112	5.1	130

**Concrete cover over reinforcement:** The minimum concrete cover over prestressed or passive positive moment reinforcement for floor, roof slabs and beams to provide an equivalent fire resistance of one to four hours is given. For slabs and beams, different minimum concrete cover thicknesses apply for restrained or unrestrained (free to expand under temperature change) situations.

**Table 5.2 Minimum cover for non-prestressed reinforcement in concrete beams**

	Beam Width		Thickness of Cover for Fire Resistance Rating									
			1 h		1.5 h		2 h		3 h		4 h	
	in.	mm	in.	mm	in.	mm	in.	mm	in.	mm	in.	mm
Restrained	5	127	3/4	19	3/4	19	3/4	19	1	25	1 ¼	32
	7	178	3/4	19	3/4	19	3/4	19	3/4	19	3/4	19
	≥ 10	≥ 254	3/4	19	3/4	19	3/4	19	3/4	19	3/4	19
Unrestrained	5	127	3/4	19	1	25	1 ¼	32	—	—	—	—
	7	178	3/4	19	3/4	19	3/4	19	1 ¾	44	3	76
	≥ 10	≥ 254	3/4	19	3/4	19	3/4	19	3/4	19	1 ¾	44

**Columns:** The minimum dimension of RC columns of different types of concrete for fire resistance rating of 1 to 4 h is given.

**Table 5.3 Minimum concrete column dimension**

Concrete Aggregate Type	Minimum Column Dimension									
	1 h		1.5 h		2 h		3 h		4 h	
	in.	mm	in.	mm	in.	mm	in.	mm	in.	mm
Siliceous	8	203	9	229	10	254	12	305	14	356
Carbonate	8	203	9	229	10	254	11	279	12	305
Sand-lightweight	8	203	8½	216	9	229	10½	267	12	305

### 5.1.2 ACI 216.1-07/ TMS 0216-07

#### Code requirements for determining the fire resistance of concrete and masonry assemblies

Fire resistance rating is measured in terms of hours of exposure to the standard fire defined by ASTM E119 (2012), e.g., the fire rating for siliceous aggregate concrete with a minimum equivalent thickness of five inches (127 mm) is two hours. Formulas are provided to calculate the equivalent thickness of non-uniform sections, such as ribbed or undulating panels, and sections consisting of multiple layers. The code also gives minimum cover thickness to protect prestressed or passive steel reinforcement against fire. Distinction is made between restrained and non-restrained members. Most cast-in-place or precast construction is restrained, whereas single spans and simply-supported end spans of multiple bays are unrestrained. For example, the minimum cover for the non-prestressed reinforcement of a restrained beam rated for two hours is ¾ in (19 mm). The data is the same as presented above since the ASCE 29-05 standards are taken from ACI 216.

Normal design procedures for concrete structures apply, with the material properties as functions of temperature (Fig. 5.1).

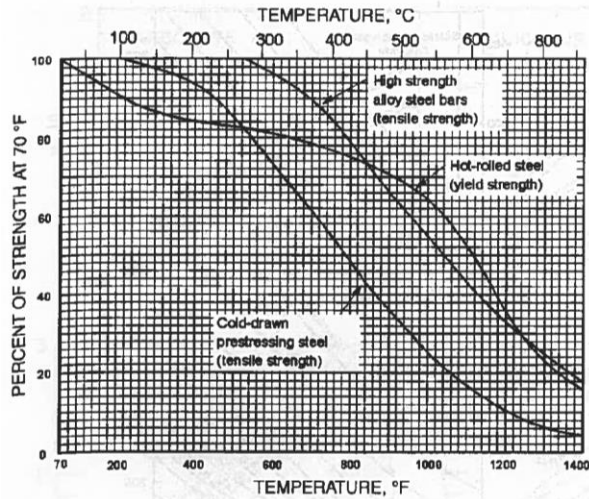

Strength of flexural reinforcement steel bar and strand at high temperatures

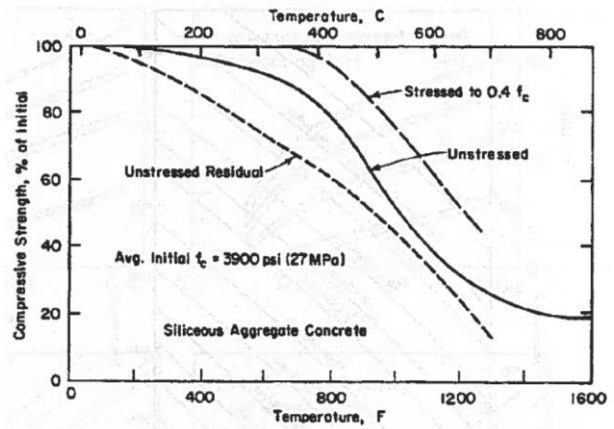

Compressive strength of siliceous aggregate concrete at high temperatures and after cooling

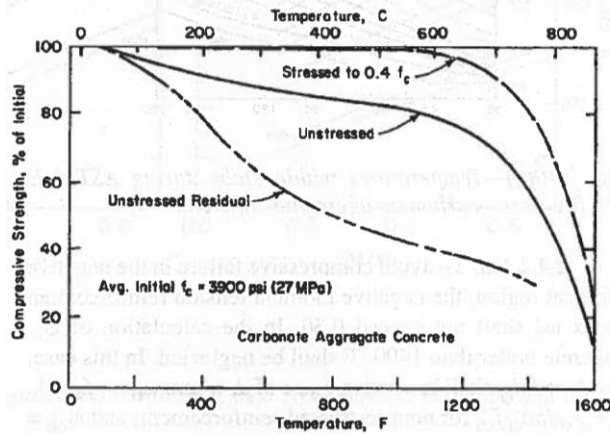

Compressive strength of carbonate aggregate concrete at high temperatures and after cooling

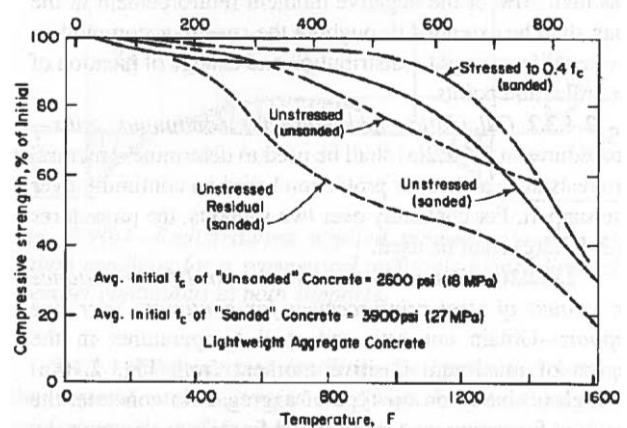

Compressive strength of semi-lightweight concrete at high temperatures and after cooling

Figure 5.1 Strength of various types of reinforcement and concrete at high temperatures (ACI 216.1-07)  
Copyright 2007 American Concrete Institute International, reprinted with permission

The *unfactored* full service load (i.e., load factor of 1.0 for both dead and live loads) is assumed constant for the entire fire resistance period. The compressive strength of various types of concrete and the tensile strength of steel bars and prestressed steel are given as functions of temperature in the form of graphs. The strength of concrete hotter than 1400°F (760°C) is neglected, thus resulting in a reduced effective depth.

For continuous beams and slabs, the fire resistance of flexural members is determined by the value of the *redistributed* maximum positive moment. As a continuous beam or slab is heated from below, its bottom expands more than its top, resulting in the ends tending to lift off, positive moments to decrease and negative moments at interior supports to increase. It is therefore advantageous to increase the

negative moment capacity. This will be explained in greater detail below (Figs. 5.3 and 5.5). To avoid compressive failure in the negative moment region, however, the tension reinforcement in these regions is limited to  $\omega = \rho f_y / f'_c \leq 0.30$ , where  $\rho = A_s / (bd)$ ,  $A_s$  is the area of steel reinforcement of yield strength  $f_y$ ,  $f'_c$  is the concrete compressive strength, and  $b$  and  $d$  are the width and depth of the beam or slab strip. The negative moment reinforcement should be long enough to accommodate the redistributed moment and the change in location of inflection points. More details are provided below in ACI 216R-89 *Guide for Determining the Fire Endurance of Concrete Elements*.

The code provides minimum dimensions for columns with concrete strength less than 12 000 psi (83 MPa) for fire ratings from one to four hours. The fire rating of steel columns protected by concrete depends on the thickness of the concrete, its degree of moisture, as well as the perimeter to weight ratio of the steel section.

ACI 216.1-07 includes charts that provide the temperature  $\theta$  for various exposure time  $t$ , concrete depth  $u$  from the fire exposed surface, and types of aggregate (Fig. 5.2). For concrete masonry, the code provides guidance on how to calculate an equivalent thickness, and how to apply that thickness to calculate the fire rating of steel columns protected by concrete masonry.

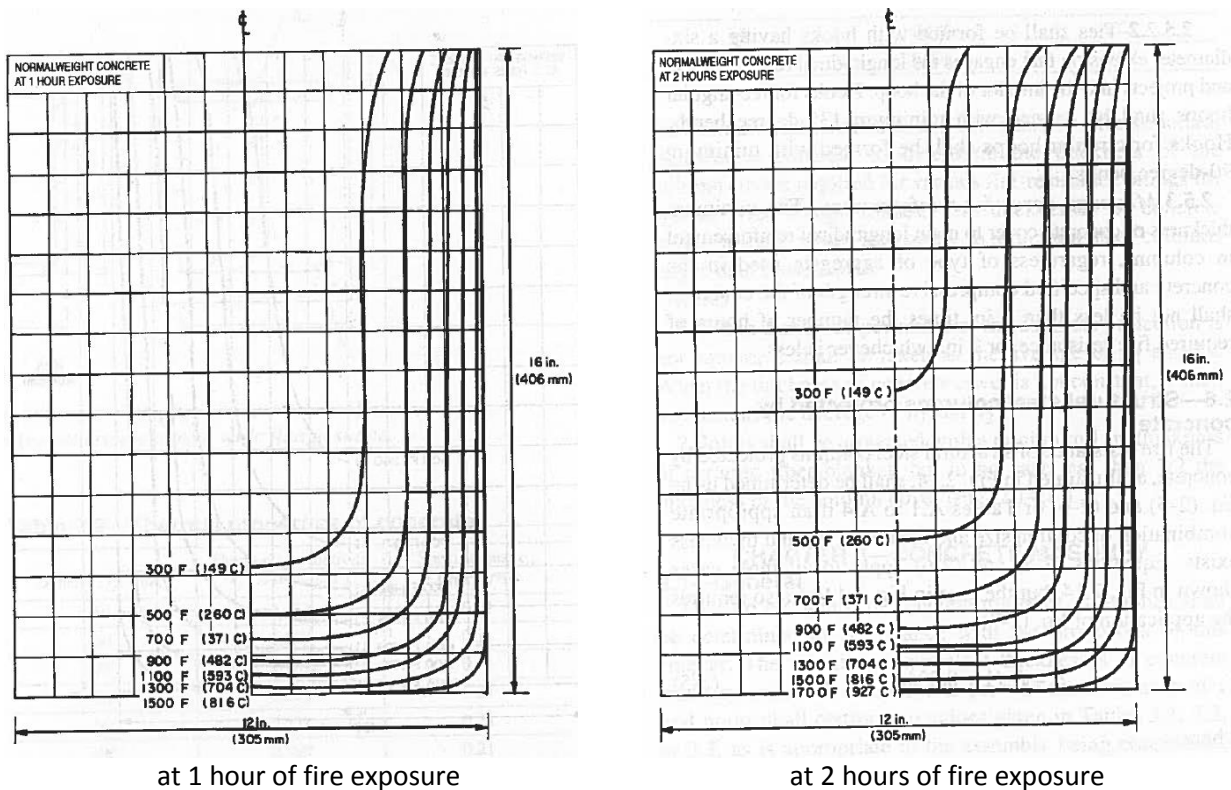

Figure 5.2 Temperature distribution in a normal weight concrete rectangular unit (ACI 216.1-07)  
Copyright 2007 American Concrete Institute International, reprinted with permission

### 5.1.3 ACI 216R-89 Guide for Determining the Fire Endurance of Concrete Elements

(Reapproved 2001, now discontinued by ACI. Although discontinued, it is covered here because of its usefulness for understanding the update in SFPE 29, discussed in Section 5.1.5 of this chapter.)

This guide provides the empirical data, the methods and examples for calculating the fire endurance of concrete beams, columns, walls, and one-way and two-way slabs. The Guide includes charts that provide the temperature  $\theta$  for various exposure time  $t$ , concrete depth  $u$  from the fire exposed surface, and types of aggregate. It also includes curves that give the strength at various temperatures of reinforcing steel and concrete of various aggregates. From these graphs, the temperature of the bottom steel ( $u$  is calculated at the center of the bar, i.e., at concrete cover plus bar radius) and of the top concrete can be determined. For corner bars,  $u$  is divided by two. The depth of the rectangular stress block and the nominal moment capacity are calculated from the familiar formulas:

$$a_{\theta} = \frac{A_s f_{y\theta}}{0.85 b f'_{c\theta}}$$
$$M_{n\theta} = A_s f_{y\theta} (d - a_{\theta}/2)$$

where

$a_{\theta}$  = depth of the rectangular stress block at temperature  $\theta$ ;

$A_s$  = area of bottom steel reinforcement;

$b$  = width of beam or slab strip;

$d$  = section depth;

$f'_{c\theta}$  = concrete strength at temperature  $\theta$ ;

$f_{y\theta}$  = yield strength of steel at temperature  $\theta$ ;

$M_{n\theta}$  = nominal bending capacity at temperature  $\theta$ .

Since  $f'_{c\theta}$  is evaluated at  $a_{\theta}/2$ , iterations are theoretically required to calculate  $a_{\theta}$ . In practice, the top concrete remains fairly cool and its properties are close to ambient. Thus, the computational method to calculate the nominal (positive) bending capacity  $M_{n\theta}$  of a beam or a one-way slab exposed for a time  $t$  to a fire from below follows the standard procedure, but with the material properties modified from ambient to temperature  $\theta$ .

A similar procedure is followed for the computation of the nominal negative moment capacity. Here, the top steel is relatively cool, and its properties are close to ambient. The bottom concrete is directly exposed to fire, and any concrete whose temperature exceeds 1400°F (760°C) is deemed to have lost its strength. The method therefore includes an additional step, which is the determination from charts of the depth of the concrete rendered ineffective.

#### Continuous beams and slabs

As continuous beams and slabs are heated from below, their bottom expands more than their top, thus causing the ends to lift and more moment to redistribute to the interior supports while positive moments decrease. The Guide provides a method to account for this effect (Figs. 5.3 and 5.5):

- From statics, express the moment equation for an *end span* of length  $l$  heated to a temperature  $\theta$ . For a beam uniformly loaded by  $w$ , with one end simply supported, the nominal positive moment  $M_{n\theta}^+$  at  $x_1$  is:

$$M_{x_1} = \frac{wlx_1}{2} - \frac{wx_1^2}{2} - \frac{M_{n\theta}^-x_1}{l} = M_{n\theta}^+$$

where  $M_{n\theta}^-$  is the negative nominal moment at the interior support at temperature  $\theta$ .

- Calculate the location  $x_1$  from the simple support of the maximum positive moment by differentiation:

$$x_1 = \frac{l}{2} - \frac{M_{n\theta}^-}{wl}$$

- Calculate the negative moment at the interior support from the previous two steps:

$$M_{n\theta}^- = m - 2m \left( \sqrt{M_{n\theta}^+ / m} \right) \text{ where } m = wl^2 / 2$$

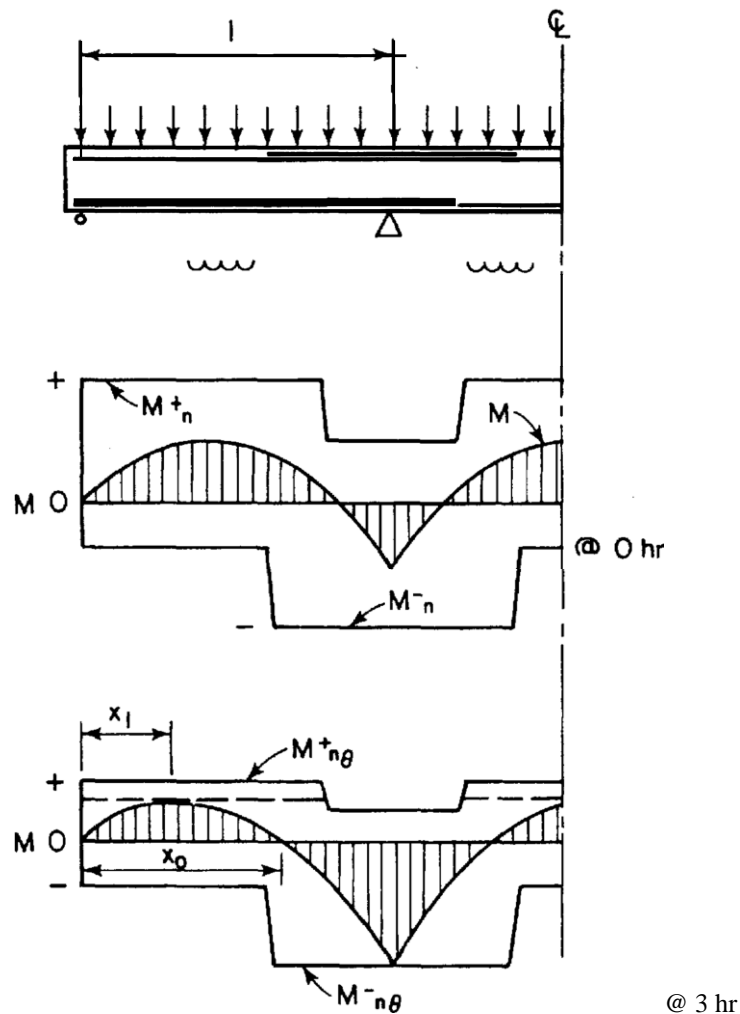

Figure 5.3 Moment diagram for one half of a continuous three-span beam before and during fire exposure (ACI 216R-89)  
Copyright 1989 American Concrete Institute International, reprinted with permission

### Restraint to thermal expansion

If restraint to thermal expansion is provided, a compressive thrust develops near the bottom of the slab. Its line of action rises as the fire progresses, but remains below the section centroid even after the maximum downward deflection is subtracted. Thus the thrust acts as a prestressing force which causes the slab to deflect upward. Restraint to thermal expansion increases the positive nominal moment and the fire resistance considerably. The procedure to account for it is complicated, even with the aid of nomographs (Fig. 5.4):

1. Determine the temperature distribution at the fire exposure duration;
2. Determine the retained nominal moment capacity  $M_{n\theta}$  at that temperature;
3. If the applied moment  $M < M_{n\theta}$ , there is no need to calculate the restraint to thermal expansion. If  $M \geq M_{n\theta}$ , calculate midspan deflection;
4. Estimate the line of action of the thrust;
5. Calculate the required thrust  $T$ ;
6. Calculate the thrust parameter  $T/(AE)$  where  $A$  is the gross section area resisting the thrust and  $E$  is the modulus of elasticity of concrete at ambient temperature;
7. Calculate  $Z' = A/s$ , where  $s$  is the heated perimeter of the section resisting the thrust;
8. From  $Z'$  and  $T/(AE)$ , find the strain parameter  $\Delta l/l$  using nomographs (Fig. 4);
9. Calculate  $\Delta l$  by multiplying the strain parameter with the length of the heated member;
10. Determine if the supports can provide  $T$  with a displacement no greater than  $\Delta l$ .

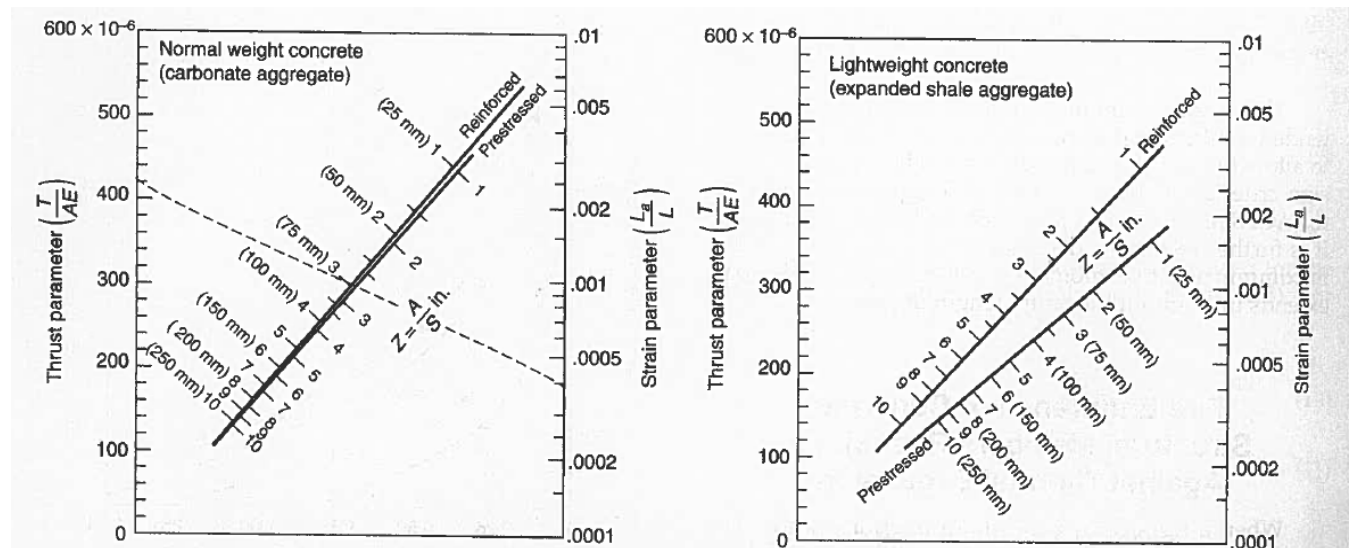

Figure 5.4 Nomographs relating thrust parameter, strain parameter, and ratio of cross-sectional area to heated perimeter (ACI 216R-89)  
Copyright 1989 American Concrete Institute International, reprinted with permission

### Fire resistance of reinforced concrete columns

Columns larger than twelve inches (305 mm) in diameter or side are assigned a fire resistance of three or four hours in most building codes in North America. The Guide provides test results that support this recommendation.

#### 5.1.4 USA: The International Building Code IBC 2012

##### Chapter 7 Fire and Smoke Protection Features.

These standards provide methods to calculate the equivalent fire resistance, in terms of hours, of concrete, timber, masonry and steel members, that would be achieved under the standard ASTM E119 fire test. It does not provide any guidance about the structural performance of members or structures under fire.

Table 721.1 of IBC 2012 prescribes the minimum thickness of various types of insulation for various fire resistance ratings (FRR) of structural members. For example, an FRR of 3 h requires a 2 in (50 mm) protective cover of concrete for a steel column. Table 722.2.3 prescribes the minimum cover thickness for reinforced (RC) or prestressed concrete (PC) slabs and beams. Table 5.4 presents an excerpt for a 3h FRR.

**Table 5.4 Excerpt from IBC Table 722.2.3 for an FRR of 3 h**

		restrained	unrestrained
slab	RC	¾ in (19 mm)	1¼ in (32 mm)
Slab, siliceous aggregate	PC	¾ in (19 mm)	2¾ in (60 mm)
beam 7 in (178 mm) wide	RC	¾ in (19 mm)	1¾ in (44 mm)
beam 8 in (203 mm) wide	PC	1¼ in (44 mm)	5 in (127 mm)

For concrete floors, walls and partitions, an FRR of 3 h requires a minimum thickness of 6.2 in (157 mm) for siliceous aggregate concrete and 5.7 in (145 mm) for carbonate aggregate concrete respectively (Table 721.1 of IBC 2012). For RC columns with concrete strength less than 12 000 psi (83 MPa), an FRR of 3 h requires minimum dimensions of 12 in (305 mm) for siliceous aggregate, 11 in (279 mm) for carbonate aggregate, and 10.5 in (267 mm) for sand-lightweight concrete. For concrete strength greater than 12 000 psi (83 MPa), the minimum column dimension is 24 in (610 mm) for FRR between 1 and 4 h. Chapter 7 of IBC also provides guidance on how to calculate fire resistance for situations not covered by tables. For example, for ribbed or undulating panels, an equivalent thickness is defined based on the ratio of the net cross sectional area to the width.

#### 5.1.5 The Society of Fire Protection Engineers

(Analytical methods for determining fire resistance of concrete members, C. Fleischmann, A. Buchanan, and J. Chang, SFPE Handbook of Fire Protection Engineering, 4<sup>th</sup> Ed. 2008) presents equations for calculating the fire resistance of simply supported beams and slabs, continuous unrestrained flexural members, and members restrained against thermal expansion. It also gives formulas for computing the axial thrust in members restrained against thermal expansion and heated from below. The effect is similar to that of a prestressing force, as presented (above) in the discontinued ACI 216 R-89 ACI Manual of Concrete Practice, of which the SFPE chapter can be considered to be an update.

The SFPE chapter generalizes the redistribution of moments for continuous unrestrained flexural members under fire to the case of unequal end moments  $M_{n\theta 1}^-$  and  $M_{n\theta 2}^-$ . The minimum positive moment  $M_{n\theta}^+$  at temperature  $\theta$  required for a beam of length  $L$  uniformly loaded by  $w$  is (Fig. 5.5):

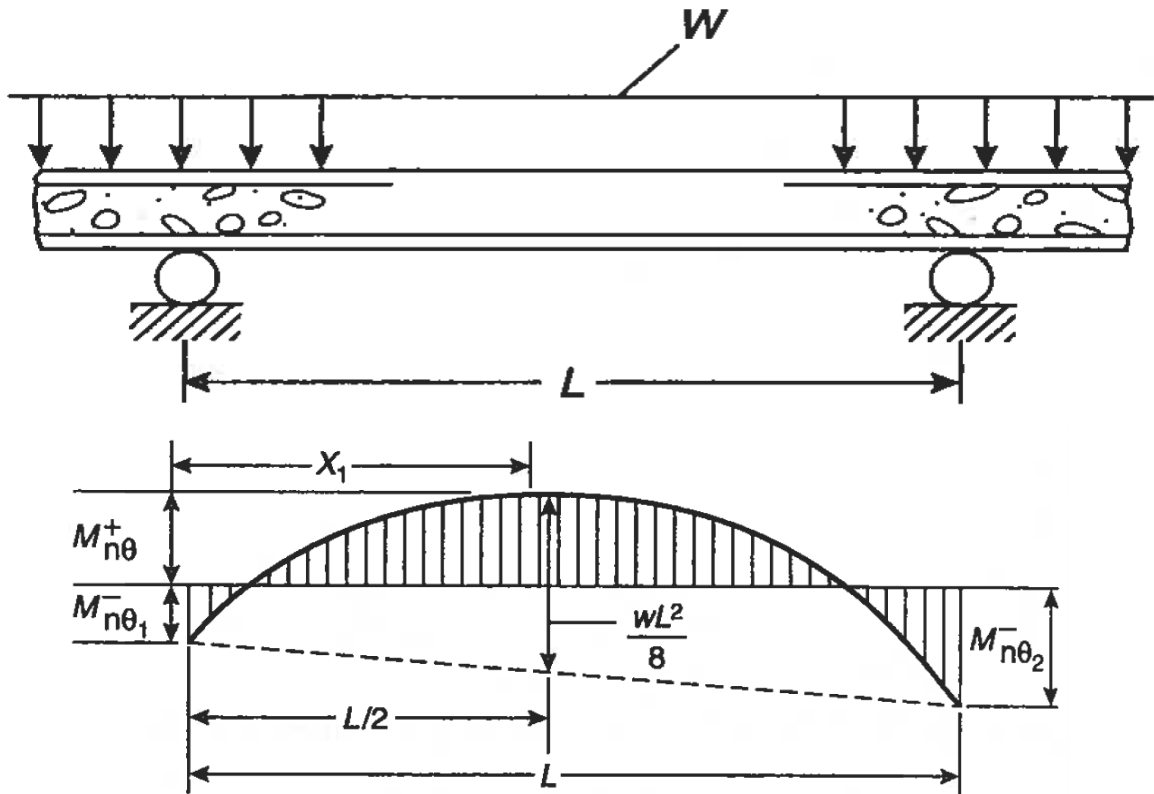

Figure 5.5 Redistributed applied bending moment diagram  
(Fleischmann et al., *SFPE Handbook of Fire Protection Engineering*, 4<sup>th</sup> Ed. 2008)  
Copyright 2008 Society of Fire Protection Engineers, reprinted with permission

$$M_{n\theta}^+ = \frac{(M_{n\theta 1}^- - M_{n\theta 2}^-)^2}{2wL^2} - \frac{M_{n\theta 1}^- + M_{n\theta 2}^-}{2} + \frac{wL^2}{8}$$

This moment occurs at a distance from end 1 of:

$$x_1 = \frac{L}{2} + \frac{M_{n\theta 1}^- - M_{n\theta 2}^-}{wL}$$

When  $M_{n\theta 1}^- = 0$ , one obtains the moment redistribution formulas of ACI 216R-89 for a simply supported end span. The thrust due to restraint of thermal expansion helps reduce the length of the top bars. The following procedure is used to account for this effect:

1. Because negative reinforcement generally yields early in fire due to moment redistribution, design reinforcement for the *maximum* (not the actual) negative moment  $M_{max}^-$  that the section can bear at an interior support.
2. Calculate the distance from the first interior support to the point of inflection (zero moment), assuming full dead load and half live load  $x_0 = 2M_{max}^-/(wL)$ .

- Use ACI specifications for the development length of the top bars beyond the inflection point (1/16 of clear span or 12 bar diameters, whichever is greater).
- If desired, use resistance to thermal expansion to reduce  $M_{max}^-$  and length of top bars. Start with the bar length required for gravity loading only and calculate the corresponding negative moment  $M_n^- = x_0 w L / 2$ . The thrust  $T$  caused by resistance to thermal expansion must produce  $M_T = M_{max}^- - M_n^-$  to reduce the bar length required under fire to the same length as under gravity only.
- Assume the location of the thrust  $T$ , say 12 mm from the bottom (Table 5.5 provides the estimation of location), and calculate  $T$  from  $M_T$ , the deflection  $\Delta$  (assumed to be 0), and an assumed depth of the compression stress block  $a_\theta^+$ . Check that the assumed stress block is correct by equilibrium  $T = M_T / (d_T - \Delta - a_\theta^+) = 0.85 f'_c b a_\theta^+$  ( $b$  is section width).

**Table 5.5 Location of thermal thrust line**

Type of construction	Fire exposure (hour)	Location of thrust line at supports*
Solid slab	2	25 mm (1 in)
	3	32 mm (1 ¼ in)
	4	38 mm (1 ½ in)
Slab-and-joint	≤ 2	0.1 $h$
	2 to 4	0.15 $h$

\*distance above bottom of member;  $h$  = overall depth of the joist and slab

- Calculate the axial strain caused by  $T$  acting on the entire section, and the ratio  $Z$  of section area to heated perimeter. Use nomographs (Fig. 5.4) to read the counteracting strain the rest of the structure must provide to resist thermal expansion.
- Verify that the structure has the strength and stiffness to resist the thrust and expand no more than calculated in step 6.
- Verify that the bar length is sufficient in the absence of resistance to thermal expansion under the *actual* negative moment.

### Reinforced concrete columns

Reinforced concrete columns generally perform well under fire because:

- columns are large enough to prevent the core from losing significant strength even during prolonged fire exposure;
- ties or spirals contain the concrete within the core; and
- the vertical reinforcing bars are protected by at least 48 mm (1 ⅞ in) of cover.

### Reinforced concrete frame

Individual members can be designed for fire by simplified methods, but moment-resisting frames require detailed computer analysis.

### Reinforced concrete walls

Usually heat transmission rather than load bearing governs the fire endurance of walls.

### 5.1.6 Spalling prevention measures in USA

There is no specific recommendation.

## 5.2 Calculation methods for concrete in Europe

**Eurocode 2: Design of concrete structures – Part 1-2: general rules – structural fire design (includes AC 2008) English translation of DIN EN 1992-1-2:2010-12**

EC 2-1-2 allows three levels of analysis: individual members, part of the structure, and global analysis. For individual member analysis, only the effects of thermal deformations resulting from thermal gradients across the cross section need to be considered, but thermal expansion and changes in boundary conditions from ambient conditions may be ignored. For analysis of part of the structure, the boundary conditions of the part are assumed unchanged from ambient conditions, but within the part of the structure to be analyzed, changes in material properties, thermal expansion and deformations are accounted for. Finally, for global analysis, all relevant modes of failure, changes in material properties and boundary conditions, thermal expansion and deformation are considered.

For standard fire exposure, members must satisfy three criteria:

- E for integrity or maintenance of fire and smoke separation function;
- I for insulation or limiting the temperature on the unexposed faces;
- and R for load bearing.

EC 2-1-2 provides tables for minimum dimensions, minimum cover thickness and design criteria for beams (R), columns (R), walls (R, E, I), and slabs (R, E, I). For example, for a rectangular column exposed to fire on more than one side, and loaded to a degree of utilization (defined as the ratio of design axial load in fire to design resistance at ambient temperature) of 0.5, a standard fire resistance of R90 (in minutes) requires a minimum column width of 300 mm and a minimum cover of 45 mm (defined as the distance from the center of the main bars to the nearest exposed surface and called axis distance).

The most commonly used design tool, recognized by EC 2-1-2, for concrete members in a compartment with a post-flashover fire is the 500°C (932°F) isotherm originally developed by Anderberg (1993). In this **simplified method**, concrete is assumed to have full ambient strength at temperatures less than 500°C, and zero strength above 500°C. The reinforcement, however, has reduced strength depending on the temperature. If the residual capacity, calculated according to these simple rules, is sufficient to carry the load factored for the fire limit state, then the section is deemed acceptable. EC2 provides 500°C isotherms for various sections (beams, columns and thick slabs) at 30, 60, 90, 120 min of a standard fire.

As an alternative, EC2 also allows the use of **advanced calculation methods**, which entail a heat transfer analysis and a structural analysis following fundamental physical behavior. The advanced analysis of concrete structures in fire must account for the degradation of material properties at elevated temperatures (Fig. 5.6). Nonlinear behavior of the structure must often be modeled as well. Due to the low thermal conductivity of concrete, an accurate representation of temperature gradients is necessary (Section 5.2.1). If moisture content is neglected, results would tend to be conservative as the thermal lag

due to water evaporation at 100°C is not observed. Cracking is usually deduced from high tensile strain regions, as in a smear crack model. Spalling is usually not modeled explicitly, but the thickness of the spalled layer can be assumed and removed at appropriate stages in the analysis (Lane, 2008).

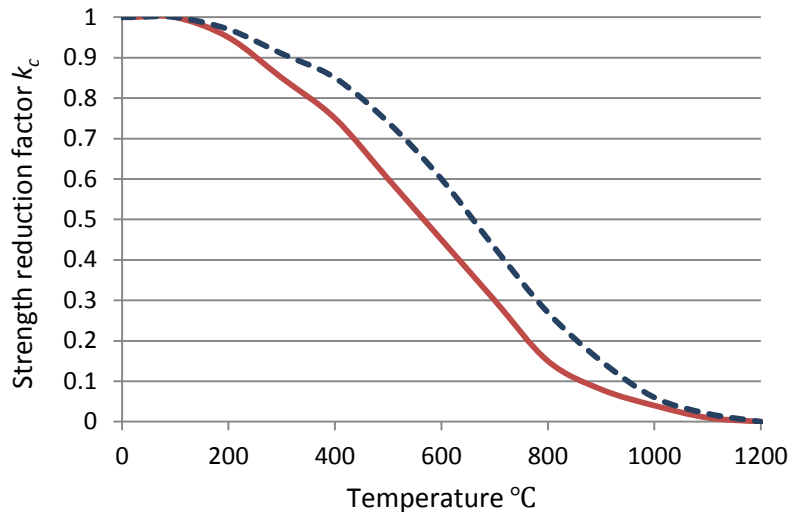

Figure 5.6 Coefficient  $k_c(\theta)$  for decrease of characteristic strength  $f_{ck}$  of normal weight concrete with siliceous (solid line) or calcareous aggregates (dashed line) (data from EN 1992-1-2:2010)

An intermediate method, detailed in Annex B of EC2-1-2, is the **zone method** for calculating fire resistance to bending moments and axial forces. The zone method applies to small sections and slender columns fully engulfed in a post-flashover fire modeled as a standard fire. The zone method divides the member into three or more zones of near equal temperature, calculates the capacity of these zones using material properties at elevated temperatures, and sums them up. Typically, a zone of damaged concrete at the surface does not contribute to the section capacity.

Annex D provides a simplified calculation method for shear, torsion and anchorage. Shear resistance in fire can be a problem for precast, pretensioned members with thin webs. Stirrups conduct heat efficiently and achieve a near uniform temperature over their length. As they pass through zones with different temperatures (the top of a beam is generally cooler than the bottom and the corners), the usual assumption of assigning to the reinforcing steel the same temperature as to the concrete is not strictly true.

Annex E provides simplified methods for the fire design of beams and slabs with uniform loading amenable to linear analysis at ambient temperature. As well, it provides simplified methods for simply supported beams and slabs and for moment redistribution (not to exceed 15 %) in continuous members. In particular, it provides a formula for the curtailment length of reinforcement over the supports, which should be checked because the point of contra-flexure may have moved due to elevated temperatures. What it does not provide is a simplified method for axially restrained beams and slabs, as can be found in the SFPE Handbook of Fire Protection Engineering. Axial restraint results in thrust, which is equivalent to additional reinforcement.

### 5.2.1 Simple one-dimensional thermal calculation for concrete (Wickstrom, 2008)

According to Eurocode 2, for standard fire exposure (defined in ISO 834) and normal weight concrete, the temperature at time  $t$  (in hours) and any depth  $x$  (in meters) inside a concrete slab uniformly heated on one surface is:

$$T_x = (1 - 0.062 t^{-0.88})[0.16 \ln(t/x^2) - 0.70] 345 \log(480 t + 1)$$

Wickstrom (1989) extended this approach to various parametric fires and material properties.

### 5.2.2 High strength concrete

EC 2-1-2 Section 6 addresses high strength concrete and provides strength reduction factors at high temperatures (Fig. 5.7).

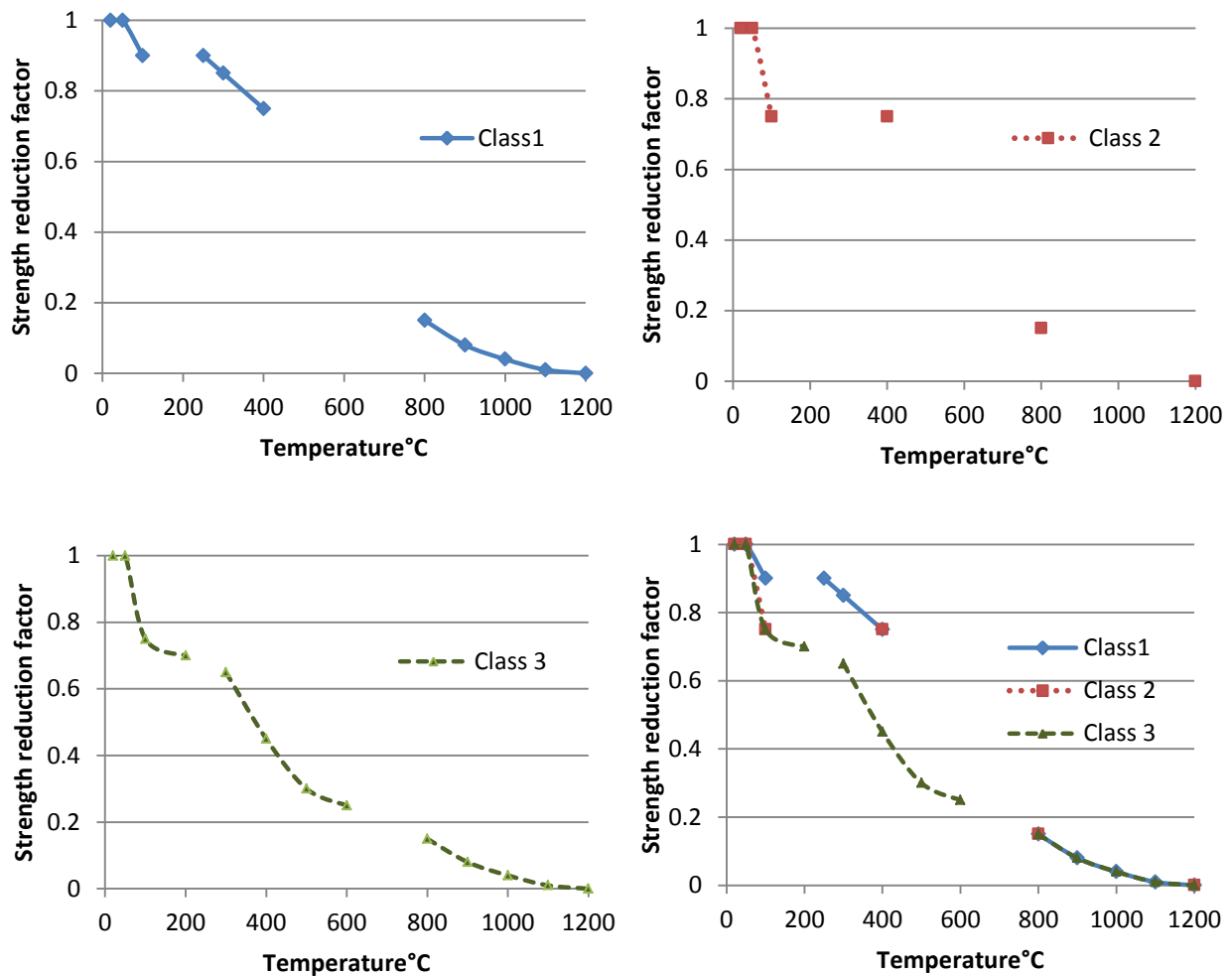

Figure 5.7 High strength concrete strength reduction factor ( $f_{c,\theta} / f_{ck}$ ) at high temperatures for Class 1 (C55/67 and C60/75), Class 2 (C70/85 and C80/95) and Class 3 (C90/105) concrete. Class ( $f_{ck,cylinder} / f_{ck,cube}$ ),  $f_{ck}$  = characteristic strength (data from EN 1992-1-2:2010).

In general, the same methodology applies as for normal strength concrete, but with a factor  $k$ . For columns and walls, the reduced concrete thickness is calculated from the depth of the 500°C isotherm increased by  $k$ , which in effect changes the isotherm to 460°C for Class 1 and 400°C for Class 2 (caption of Fig. 5.7 defines classes). For beams and slabs, the calculated moment capacity corresponding to the 500°C isotherm is reduced by a factor  $0.85 \leq k_m \leq 0.98$ .

### 5.2.3 Spalling

An important phenomenon to consider for concrete in fire is spalling, which is due to the build-up of pressure caused by the evaporation of water in the pores. The major factors affecting spalling are:

- concrete strength, with high strength concrete more susceptible to spalling than normal strength concrete.
- the type of aggregate; limestone aggregates are less susceptible to spalling than silica, quartzite and granite aggregates; and concrete that uses manufactured lightweight aggregates is found unlikely to spall.
- the heating rate; a faster rate increases the risk of spalling.
- the dimensions of the member and cover thickness.
- large compressive stresses, and the amount of restraint against thermal expansion.
- high moisture content (over 5 % by volume or 2 % to 3 % by mass of dense concrete).
- the most important parameter is the permeability, which can be controlled by the addition of polypropylene fibers.

For covers exceeding 40 mm to 50 mm, the use of the following measures to alleviate spalling is acceptable:

- a protective layer of plaster, vermiculite or similar material, sprayed or applied manually;
- a false ceiling as a fire barrier;
- lightweight aggregates;
- sacrificial steel, such as welded steel fabric placed within the concrete cover at 20 mm from the concrete face.

In addition, Eurocode EC 2-1-2 recommends limiting the moisture content of concrete to control explosive spalling. The recommended limiting moisture content by mass is  $m_c = 3\%$ . If the moisture content exceeds  $m_c$ , spalling effect on load bearing may be assessed by assuming local loss of cover to one reinforcing bar or bundle of bars in the cross section, then calculating the ensuing rise in temperature and the reduced load bearing function  $R$ . Eurocode provides specific provisions for prevention of spalling in high strength concrete. For concrete with cube strength between 55 MPa and 80 MPa, or cylinder strength between 67 MPa and 95 MPa ( $55/67 < C \text{ grade} < 80/95$ ), and with fly ash content less than 6 % of cement weight, the recommendations for normal strength concrete apply. If the fly ash content is higher than 6 %, further measures are necessary. Likewise, for  $80/95 < C \text{ grade} < 90/105$ , at least one of the following measures must be provided:

- A. A reinforcement mesh with nominal cover of 15 mm, wire diameter not less than 2 mm, pitch not more than 50 mm × 50 mm. The nominal cover to the main reinforcement should not be less than 40 mm.

- B. Show by testing or experience that the concrete used exhibits no spalling under fire exposure.
- C. Protective layers demonstrated to prevent spalling under fire.
- D. Include in the concrete mixture more than  $2 \text{ kg/m}^3$  of monofilament polypropylene.

If it can be shown (by member virtual removal) that a frame remains stable when an individual member has lost its strength due to a local fire, then spalling prevention is not required for that member. Normally, members impinged on by flames, or whose reinforcement cover temperature exceeds  $100^\circ\text{C}$ , must be designed to prevent spalling (Lane 2008).

### **5.3 Calculation methods for concrete used in New Zealand and Australia**

**New Zealand Standards Concrete Structure Standard - Part 1: The design of concrete structures**  
**NZS 3101: Part 1: 2006, with amendments Aug. 2008, Chapter 4: Design for fire resistance**

The standards start out by mentioning performance criteria: “A member shall be designed to have a fire resistance rating (FRR) for each of structural adequacy, integrity and insulation equal to or greater than the required fire resistance. The criteria for integrity shall be considered to be satisfied if the member meets the criteria for both insulation and structural adequacy for that period, if applicable.”

To achieve these performance criteria, prescriptive tables are provided for minimum dimensions corresponding to various FRR (from 30 to 240 minutes) for the structural adequacy of slabs and simply supported or continuous beams. Similar tables are provided for columns and walls, with an additional parameter, namely, the load level  $\eta_{fi}$ , taken as 0.7 or calculated as  $\eta_{fi} = N_{fi}^*/N_u$ , where  $N_{fi}^*$  is the factored design axial load in fire conditions, and  $N_u$  is the axial load capacity at normal temperature. The standard provides guidance on the thickness of insulation required to achieve a given FRR, and also allows the calculation of FRR by recognized methods, such as Eurocode 2.

#### **Australian Standards AS 3600 - 2009 Concrete structures**

AS 3600, like NZS 3101, specifies minimum dimensions and cover thickness for concrete sections to achieve a given fire rating or duration of resistance to a standard fire. Standard calculation methods are used, but with material properties at ambient replaced by those at elevated temperatures.

#### **Spalling prevention measures in Australia and New Zealand**

There are no specific recommendations, but reference is made to British Standards BS 8110 Part 2, Clauses 4.1.6 and 4.1.7. These are similar to Eurocode provisions described above.

### **5.4 2010 National Building Code of Canada,**

#### **Division B, Appendix D, Fire Performance Rating**

This Appendix prescribes minimum dimensions and cover thickness for various structural members. Table D-2.2.1.A lists the minimum thickness of reinforced and prestressed concrete floor and roof slabs,

e.g., for 1 h fire resistance rating, the minimum thickness for type S concrete is 90 mm, for type N, it is 87 mm, and for type L40S or Type L concrete, it is 72 mm. Table D-2.2.1.B gives the minimum concrete cover over reinforcement in concrete slabs, e.g., for 1 h fire resistance rating, the minimum cover for type S, N, L40S or L concrete is 20 mm for reinforced concrete (RC) slabs, and 25 mm for prestressed concrete (PC) slabs. Table D-2.6.1.A provides the minimum thickness of concrete or masonry protection to steel columns, e.g., for an FRR of 1h, monolithic concrete protection of 25 mm is required. Table D-2.9.1 shows the minimum cover to principal steel reinforcement in RC beams, e.g., for 1 h rating, 20 mm is required. Table D-2.10.1 specifies the minimum cover over steel tendons in PC beams, e.g., for beams made of type S or N concrete and with areas between 260 and 970 cm<sup>2</sup>, 1 h rating requires 50 mm minimum cover.

The minimum dimensions of a rectangular RC column is required to be  $t \text{ (mm)} = 75 f (R+1)$  for all types L and L40S concrete, where  $R$  is the required fire resistance rating in hours and  $f$  is a factor that depends on the effective length factor  $k$ , the unsupported length  $h$  of the column, the ratio  $\rho$  of vertical reinforcement area to column area, and the overdesign factor ODF, which is the ratio of the calculated load carrying capacity to the column strength required to carry the specified loads. For example,  $f = 1.2$  for  $ODF = 1.00$ ,  $3.7 \text{ m} < kh \leq 7.3 \text{ m}$ ,  $t \leq 300 \text{ mm}$ , and  $\rho \leq 3\%$ . For  $R = 3 \text{ h}$ ,  $t = 75 \times 1.2 (3+1) = 360 \text{ mm} > 300 \text{ mm}$ . Therefore choose  $f = 1.0$  (all other cases) and  $t = 75 \times 1.0 (3+1) = 300 \text{ mm}$  (Section D2.8.2). Supporting members are required to have an FRR not less than that of the supported members.

**CSA Standard A23.3-04 (2004) Design of concrete structures**

This standard has no specific provisions concerning fire.

**5.5 The Building Standard Law of Japan, August 2011**

The code gives minimum dimensions and cover thickness for RC members (Hasegawa, 2013).

**Table 5.6 Minimum dimensions and cover thickness for RC members**

Member	Fire resistance time, min	Minimum dimension, mm	Minimum cover thickness, mm
Load bearing walls	60	70	30
	120	100	30
	60		30
Columns	120	250	30
	180	400	30
	60, 120, 180		30
Beams	60, 120, 180		30
Floors	60	70	20
	120	100	20

In general, when the minimum cover depth is 20 mm larger than the cover depth required for normal environment, the verification for fire resistance can be omitted. For normal environment, cover thickness is specified to alleviate corrosion due to carbonation. When no fire resistance is required, the minimum concrete cover is the larger of the reinforcing bar diameter and the cover that meets durability requirement, plus a margin of construction error (Standard specifications for concrete structures - 2007).

**Notification 1433, Reinforced concrete (RC) members, p. 104**

This document provides detailed calculation methods for fire resistance. The retained fire resistance time of RC columns and beams depends on the thermal degradation depth and should not be less than the time it takes the fire to reach a temperature of 480°C. RC columns and beams with standard strength at normal temperature  $F_c \leq 60$  MPa, minimum width/length  $\leq 10$  and concrete cover  $\geq 3$  cm, have retained fire resistance time  $t_{fr}$  in minutes:

$$t_{fr} = \max \left\{ \frac{16772(cd)^2}{\alpha^{3/2} \left( \ln \frac{0.673}{(cd)^{1/3}} \right)^2}, \left( \frac{480}{\alpha} \right)^6 \right\}$$

where

$\alpha$  = fire temperature rise coefficient ( $^{\circ}\text{C}/\text{min}^{1/6}$ ). The fire temperature  $T_f$   $^{\circ}\text{C}$  is (Chapter 3):

$T_f = \alpha t^{1/6}$ , with  $t$  = time (min);

$c$  = thermal property coefficient = 0.21 for normal concrete, 0.23 for lightweight concrete;

$d$  = thermal degradation depth mm.

For RC columns, a thermal degradation depth (p. 104) less than twice the concrete cover is calculated for columns loaded beyond  $(2/3)F_c A_c$

$$d = \min \left\{ \frac{A_c - 3P/(2F_c)}{H_c}, 2d_s \right\}$$

$A_c$  = column cross section area;

$H_c$  = heated perimeter of column cross section;

$P$  = compressive force on column;

$d_s$  = minimum value of concrete cover in heated parts.

For RC beams a similar but more complicated equation is provided for the thermal degradation depth.

**RC walls**

RC load-bearing walls with standard strength at normal temperature  $F_c \leq 60$  MPa and concrete cover  $\geq 3$  cm, have retained fire resistance time  $t_{fr}$  in minutes:

$$t_{fr} = \min \left[ \max \left\{ \frac{16772(cd)^2}{\alpha^{3/2} \left( \ln \frac{0.673}{(cd)^{1/3}} \right)^2}, \left( \frac{480}{\alpha} \right)^6 \right\}, \frac{118.4 c_D D^2}{\alpha^{3/2}} \right]$$

where

$c_D$  = thermal insulating coefficient = 1.0 for normal concrete, 1.2 for lightweight concrete.

$D$  = wall thickness mm.

The thermal degradation depth is given by:

$$d = \min \left\{ D - \frac{3P}{2F_c}, 2d_s \right\}$$

where  $P$  = load on wall N/mm.

For non load-bearing walls,

$$t_{fr} = \frac{118.4 c_D D^2}{\alpha^{3/2}}$$

## 5.6 Critical assessment

All building codes studied have a prescriptive method, whereby minimum member dimensions and reinforcement cover are prescribed for a given rating of time of exposure to a standard fire. Performance-based methods allow more precise determination of fire resistance by calculating the temperature distribution throughout the member and accounting for the reduction in strength and stiffness of the materials. Isotherms are provided by most codes for common members exposed to a standard fire. Beyond a certain temperature, concrete is considered so degraded that its contribution to member strength can be neglected. Redistribution of moments in continuous members, development of axial thrust due to restraint against thermal expansion, special provisions for high strength concrete, and design to resist spalling are among the issues that some codes address in greater detail than others.

In the US, the SFPE handbook and ACI 216 have a more detailed method on how to account for the axial thrust generated by resistance to thermal expansion than any method found in Eurocode 2 utilization but in several other aspects, Eurocode is more complete than US standards. These include: methods for preventing spalling, thickness of spalled layer to remove in design calculations; account for the actual degree of utilization of the concrete member in fire design; strength reduction in high-strength concrete (up to 90 MPa or 13 ksi cylinder strength) at elevated temperatures. (ACI 216 does not provide guidance on high strength concrete, whereas IBC 2012 specifies minimum dimensions for columns made of concrete 83 MPa or 12 ksi or above in strength for a given fire resistance rating.) In addition, ACI neglects the strength of concrete above 760°C, whereas Eurocode neglects it above 500°C, a rather significant difference worth exploring further.

It is recommended that US code provisions for spalling of concrete, especially high strength concrete be developed.

## References

American Concrete Institute (2007) "ACI 216.1-07/TMS 0216-07 Code requirements for Determining fire Resistance of Concrete and Masonry Assemblies," Farmington Hills, MI

American Concrete Institute (2001) "ACI 216R-89 Guide for Determining the Fire Endurance of Concrete Elements," (reapproved 2001, now discontinued by ACI) Farmington Hills, MI

American Society of Civil Engineers (2007) "ASCE/SEI/SFPE 29-05 Standard Calculation Methods for Structural Fire Protection," Reston, VA, USA

Anderberg, Y. (1993) "Computer simulation and a design method for fire exposed concrete columns," Report 92-50 Fire Safety Design, Lund, Sweden

ASTM E119 (2012) "Standard Test Methods for Fire Tests of Building Construction and Materials," American Society for Testing and Materials, West Conshohocken, Pa

Building Center of Japan (2011) "The Building Standard Law of Japan," Tokyo, Japan

Canadian Standards Association (2004) "*CSA A23.3-04 Design of Concrete Structures*," Toronto, ON, Canada

Eurocode 2 (2010) "Design of concrete structures – Part 1-2: general rules – structural fire design (includes AC 2008)," English translation of DIN EN 1992-1-2:2010-12, CEN, Brussels, Belgium

Fleischmann, C., Buchanan, A. and Chang, J. (2008) "Analytical methods for determining fire resistance of concrete members," SFPE Handbook of Fire Protection Engineering, 4<sup>th</sup> Ed., NFPA, Quincy, MA

Hasegawa, T. (2013) [hasegawa-t2gg@mlit.go.jp](mailto:hasegawa-t2gg@mlit.go.jp) "Introduction to the Building Standard Law, version Feb 2013," Building Center of Japan, Tokyo, Japan

International Code Council (2012) "*International Building Code*," Chapter 7: Fire and Smoke Protection Features, Country Club Hills, IL, USA

Japan Society of Civil Engineers (2007) "Standard specifications for concrete structures-2007-Design," Section 10.7, Tokyo, Japan

Lane, B. (2008) "Approaches to calculating structural fire resistance," NFPA Fire Protection Handbook, 12<sup>th</sup> ed., Vol. II, Chap. 19.5, Cote, A.E. Ed. National Fire Protection Association, Quincy, MA. USA pp. 19.77-19.126

National Research Council Canada (2010) "*National Building Code of Canada 2010*" (NBCC), Division B, Appendix D, Fire performance rating, Institute of Research in Construction, Ottawa, ON, Canada

New Zealand Standards (2006) "*NZS 3101: Concrete Structures Standard - Part 1: The Design of Concrete Structures 2006, with amendments Aug. 2008*," Chapter 4: Design for Fire Resistance, Wellington, NZ

Standards Australia (2009) "*AS 3600-2009 Concrete structures*," Sydney, NSW, Australia

Wickstrom, U. (1989) "Natural fires for design of steel and concrete structures- a Swedish approach," Int. Symp. on Fire Engg. for Building Structures and Safety, Inst. of Engrs, Australia, Nat. Conf. Pub. 89/16, Melbourne.

Wickstrom, U. (2008) "Methods for predicting temperatures in fire-exposed structures," SFPE Fire Protection Engineering, 4<sup>th</sup> ed.

## Chapter 6 Composite Structures

The most common composite steel and concrete members are concrete floor slabs connected to steel sheeting or beams by shear studs, hollow steel sections filled with reinforced concrete, or hot rolled steel sections encased in concrete. The strength of composite slabs is severely influenced by fire because the steel sheeting under fire loses its strength as external reinforcing. Composite slabs, however, still provide good performance under fire because of axial restraint, moment redistribution and internal reinforcement.

### 6.1 AISC 2011 14<sup>th</sup> Ed. Appendix 4 Structural Design for Fire Conditions - Composite floor members

For the simplified analysis, the AISC Specifications allow the use of 1D heat transfer equations, whereby the temperature is assumed to be uniform from the bottom flange to midweb, and to decrease linearly by no more than 25 % from midweb to the top flange. The mechanical properties of the steel beam are taken as functions of temperature.

AISC Steel Design Guide 19 (2003) provides more detailed guidance. The concrete properties are unchanged from ambient as the temperature on the top of the slab does not rise dramatically. The neutral axis is assumed to be within the concrete slab for the purpose of calculating the positive moment capacity, which is the sum of the moment capacities of the top flange, the web and the bottom flange, calculated at elevated temperatures. The location of the neutral axis is verified using concrete properties at ambient temperature. For negative moment capacity, an iterative approach is used, with the assumptions that the steel reinforcement of the slab is fully yielded in tension and the neutral axis is located in the web in the first iteration. A change in the moment distribution in continuous beams as temperature increases (see Section 5.1.3, continuous beams and slabs) is also accounted for.

### 6.2 ASCE /SEI/SFPE 29-05 Standard Calculation Methods for Structural Fire Protection - Concrete-filled hollow steel tubes (Section 5.2.3)

In composite concrete filled hollow steel sections, the concrete acts as a heat sink and slows the temperature rise of the steel column; it also assumes an increasing part of the axial load as the steel weakens under fire; and it inhibits local buckling of the steel section. ASCE gives the fire resistance rating  $R \leq 2$  hrs of hollow steel columns filled with unreinforced normal weight concrete as:

$$R = 0.58 a \frac{f'_c + 2.90}{KL - 3.28} D^2 \sqrt{\frac{D}{C}} \text{ in US units}$$

$$R = a \frac{f'_c + 20}{60 (KL - 1000)} D^2 \sqrt{\frac{D}{C}} \text{ in SI units}$$

where

$a$  = constant given in Table 6.1;

$f'_c$  = 28-day compressive strength of concrete;  $5.80 \leq f'_c \leq 2.90$  ksi or  $40 \leq f'_c \leq 20$  MPa;

$KL$  = effective length of column;  $6.5 \leq KL \leq 13$  ft or  $2000 \leq KL \leq 4000$  mm;

$D$  = outside diameter of circular column;  $5.5 \leq D \leq 16$  in or  $140 \leq D \leq 410$  mm;

$D$  = outside dimension of square column;  $5.5 \leq D \leq 12$  in or  $140 \leq D \leq 305$  mm;

$D$  = least outside dimension of rectangular column;  $5.5 \leq D \leq 12$  in or  $140 \leq D \leq 305$  mm;

$C$  = compressive force due to unfactored dead load and live load (kips or kN)  $\leq$  design strength of concrete core.

**Table 6.1 Values of constant  $a$  (ASCE)**

Aggregate	Circular columns	Square or rectangular columns
siliceous	0.07	0.06
carbonate	0.08	0.07

These equations are based on an extensive series of test, performed by the National Research Council of Canada, of unprotected concrete filled steel columns, 3.810 m in length, with ends rotationally restrained and exposed to ASTM E119 fire. The tests comprise various types of concrete (siliceous or carbonate aggregate, normal or high strength); types or reinforcement (none, steel bars, steel fibers); square and circular hollow steel sections of various dimensions; and load ratios (Kodur, 1998; Lie and Chabot, 1992; Lie and Kodur, 1996). Typical test results show axial expansion at the beginning of the fire, followed by sharp contraction, then a more gradual contraction. A final drastic contraction occurs just before failure.

### 6.3 National Building Code of Canada 2010

The same SI formula as above is recast for the capacity  $C_{max}$  of the concrete-filled steel column with a given fire rating  $R$  in minutes, with  $a$  given in Table 6.2:

$$C_{max} = \left( \frac{a(f'_c + 20)D^{2.5}}{R(KL - 1000)} \right)^2$$

**Table 6.2 Values of constant  $\alpha$  (NBCC)**

Concrete type	Steel reinforcement	Reinforcement ratio %	Circular columns	Square columns
S*	Plain	0	0.070	0.060
S	Fiber	$\approx 2$	0.075	0.065
S	Bar	1.5 to 3	0.080	0.070
S	Bar	3 to 5	0.085	0.075
N <sup>+</sup>	Plain	0	0.080	0.070
N	Fiber	$\approx 2$	0.085	0.075
N	Bar	1.5 to 3	0.090	0.080
N	Bar	3 to 5	0.095	0.085

\* S: coarse aggregate is granite, quartzite, siliceous gravel or other dense materials containing at least 30% quartz, chert or flint;

+ N: coarse aggregate is cinders, brick, blast furnace slag, limestone, calcareous gravel, trap rock, sandstone or similar dense materials containing at least 30% quartz, chert or flint.

#### 6.4 The Building Standard Law of Japan Aug. 2011

No special provision is available for composite construction. For methods of fire-resistive construction other than those explicitly mentioned, the retained fire resistance time against enclosure fire  $t_{fr}$  is calculated by (Notification 1433 Aug. 2011 p. 105):

$$t_{fr} = t_A \left( \frac{460}{\alpha} \right)^{3/2}$$

where

$t_A$  = fire resistance rating (min);

$\alpha$  = fire temperature rise coefficient.

#### 6.5 Eurocode 4: EN 1994-1-2, Aug. 2005 - Design of composite steel and concrete structures – Part 1-2: General rules - structural fire design

Simple calculation models are given for slabs, beams and columns of steel-concrete composite construction under standard fire exposure. Columns are assumed to be heated all around, whereas beams supporting floors are heated from the three lower sides. For composite slabs and beams, the bending design resistance is governed by plastic theory (or ultimate strength), whereby the concrete contribution is modeled by the rectangular stress block and the tension reinforcement is at yield. Material properties are multiplied by a reduction factor that is a function of temperature. For composite beam-slab systems with full shear connection, Eurocode 4 Part 1.2 method consists in obtaining the temperature distribution in the cross section exposed to a standard fire, dividing the section into slices of approximately the same temperature, calculating the plastic bending moment of each cross sectional slice, and summing them up. A protected composite slab is assumed to have fulfilled its load bearing function  $R$  if the temperature of the steel sheet is less than or equal to 350°C when heated from below by a standard fire.

In case of design by partial shear connection in a fire situation, the variation of longitudinal shear forces in function of the heating needs to be considered. For composite beams with no concrete encasement around the beam, the temperature of the stud connectors and of the concrete may be taken as 80 %

and 40 % respectively of the temperature of the upper flange of the beam. If the beam is partially encased in concrete, it may be assumed that there is no reduction in the shear resistance of the connectors welded to the effective width of the upper flange. The limiting temperature approach can be used (see Section 4.2.2, Chapter 4). Reflecting the lower heating rate of the shear connectors, EC4-1-2 specifies a higher limiting temperature for partial shear connections than for full shear connections.

### **Slab membrane action in fire**

The load bearing calculation of a composite slab in fire typically assumes one-way spanning, in the direction of the concrete rib. This simplification is conservative compared to the tensile membrane behavior that occurs in reality.

EC4 also allows the use of yield line theory for the fire design of continuous slabs. Minimum reinforcement at supports and midspan is specified to ensure sufficient deformation capacity. For positive (sagging) bending, the concrete in compression is at the top and is required to be below 140°C (284° F) per insulation standard. Therefore, ambient material properties may be used. The contribution from the unprotected steel decking is usually ignored because it might debond under direct fire attack. Tension is resisted by the reinforcement in the ribs, whose temperature can be calculated with the aid of nomograms. For negative bending of a continuous slab, the compression face is exposed to fire and sees a steep temperature gradient. As mentioned above, it is then necessary to divide the slab, including the ribs, into layers of varying temperature and integrate the contributions of all layers with their reduced stiffness and strength properties.

According to Lane (2008), simple design guidance based on Bailey's analysis (Bailey et al., 2000) of the Cardington frame fire tests and similar tests in Australia and Europe were published by the Steel Construction Institute of the UK (Guide SCI-P288, Newman et al., 2000, 2006). By accounting for the tensile membrane action of composite slabs in fire, the guide allows secondary beams in composite steel-framed structures to be left unprotected. The recommendations are restricted to non-sway frames with composite steel decks similar to the Cardington tests. The slabs should be made of normal or light weight concrete with reinforcement mesh and steel decking of trapezoidal or reentrant geometry. The design method, based on a standard fire exposure and the yield line theory of slabs, is comprised of tables for various beam spans, reinforcement meshes, slab profiles and loads.

The maximum fire resistance achievable with the use of the Guide is 60 minutes. Slab reinforcement detailing is governed by limits on deflections ( $\text{span}/30$ ) to ensure that compartmentalization is not breached and steel stresses do not exceed  $f_y/2$ . The method requires that the floor be divided into rectangles of less than 9 m span, with the rectangles supported by unprotected beams surrounded by other rectangles with fully protected beams. Primary and edge beams must be protected. The Guide accounts for the additional loads induced on the beams by the membrane action of the floor slab. The 2006 edition of the Guide (SCI-P288) also accounts for the catenary behavior of the beams, and extends the method to orthotropic slab reinforcement. Usmani and Cameron (2004) extended the method further by modeling the deflected shape of the slab with a cubic polynomial before calculating the

membrane forces. Further refinement includes the pulling in of columns under high floor membrane action based on the work of Wang (1996, 2005) and published by HERA in New Zealand (Clifton, 1998).

### **Composite columns**

EN4-1-2 gives a detailed fire design method for composite columns. Three approaches are presented: 1) tabulated data, 2) simple calculations, and 3) advanced calculations.

Design tables are available for a limited range of load ratios and steel sections, and steel columns of buckling length less than 4.5 m. Simple calculation methods (Annex H) are also limited to buckling lengths less than 4.5 m, but can be used for any section and any load ratio. Tabulated data are available for columns heated all around by a standard fire, with the same temperature distribution over their whole length. The tables account for the column load level, which is the ratio between the relevant design effect of actions in fire and the design resistance for ambient temperature.

Under “simple calculations” for columns, the design value of the plastic resistance for axial compression in fire is the sum of the contributions of the steel profile, the reinforcing bars and the concrete, with material properties reduced at elevated temperature. A complicated step by step approach is necessary, whereby, at each value of column strain, the plastic resistance and the Euler buckling load are calculated. The Euler buckling load is evaluated using the tangent modulus at the appropriate column strain and temperature. When the plastic resistance equals the Euler buckling load, that load is the design compressive strength of the composite column.

Advanced calculation methods are based on fundamental physical behavior and provide a realistic analysis of structures exposed to fire. They account for mechanical actions, geometrical imperfections, thermal actions, temperature-dependent material properties, geometric non-linear effects and non-linear material properties, including the effects of unloading. The influence of moisture migration on the thermal response of the concrete and the fire insulation may be neglected.

## **6.6 Composite members in New Zealand (NZS 3404) and Australia (AS 4100)**

The limiting temperature method is also used. Composite columns are designed within the performance-based framework. In New Zealand, Clifton (2006) developed the Slab Panel Method (SPM) to take into account the inelastic reserve strength of composite slab construction. The SPM formulates Bailey et al.'s (2000) tensile membrane action of composite slabs, observed in the Cardington tests, for general application to steel framed buildings with composite floors on steel deck. SPM applies to concrete floor systems integral with supporting steel beams in buildings subjected to fully developed fires. Under these conditions, and especially if steel members are unprotected, the inelastic demand on the floor system can be considerable. SPM estimates this demand and compares it to the reserve strength made available by large deformations of the composite floor. SPM also calculates the minimum detailing requirements to ensure the expected deformations can be achieved without failure of reinforcement or connections. The highest inelastic demand on the connections occurs during the cooling phase, when large tension forces develop. Improvements of SPM over Bailey et al.'s approach include 1) the

incorporation of the supporting beams directly into the flexural/tensile capacity of the slab, 2) a check of the shear capacity of the slab, and 3) an update on the limits on maximum slab deflection (Oliver et al. 2008). AS/NZS 2327: Composite Structures is planning a 2014 release of a new standard for composite steel-concrete buildings, which will be informed by overseas standards such as AISC and Eurocode, but will also include SPM for fire design. The new standard acknowledges that, for indeterminate systems in fire, there is a significant degree of redundancy that provides additional structural capacity that cannot be addressed by considering single elements within a building (Uy, 2013).

## 6.7 Critical assessment

Eurocode has made extensive use of the results of the Cardington tests to provide guidance on the development of tensile membrane action, leading to savings in fireproofing and more efficient design of composite reinforced concrete (RC) floor slab-steel beam systems. In the US, the performance in fire of composite floor systems comprising a concrete deck poured over corrugated steel sections supported by open-web joists (NCSTAR 1 (2005)) or conventional beams (NCSTAR 1A (2008)) was studied by NIST as part of the World Trade Center investigation. NCSTAR 1 (2005) noted that deflections greater than span/20 were required for tensile membrane action to develop in the case of concrete slabs supported by open web joists, but this form of construction is less widely used than the conventional steel beam-concrete slab. As there are differences in construction methods between the US and Europe, the results of the Cardington tests may not be directly applicable to the US. Guidance is needed on when tensile membrane action can be relied upon in fire, e.g., the reinforcement, anchorage, boundary conditions required, as appropriate to US construction.

The challenge, as always, is to produce design methods that are safe, not overly conservative, and simple to use. This challenge is illustrated by the difference in approach between North America and Europe on the design of concrete-filled steel tubular columns. US standards are based on Canadian tests, and are therefore limited to the range of geometries and concrete types of these tests. (Eurocode standards are more complete, but more complex, although simplified methods are also offered.) There is also a need for more research and standards for composite columns within a structural assembly. For CFT columns, the steel tube may experience local buckling at the ends or along the length under fire exposure. If local buckling occurs at the ends, then the column should be considered pinned, but there is no clear guidance on when that happens, only indications that the location of the local buckling depends on the axial load, the thickness of the steel tube, and the bond between the steel tube and the concrete core (Wang, 2005).

It is therefore recommended that further research be undertaken to 1) develop guidance appropriate to US construction techniques for the development of tensile membrane action of steel beam-concrete slab composites under fire; and 2) expand the scope of US code provisions for concrete-filled tube (CFT) columns.

## References

American Institute of Steel Construction Steel (2011) *"AISC Construction Manual, Appendix 4: Structural Design for Fire Conditions,"* part of *"Specifications for Structural Steel Buildings,"* (adopted 2010), 14<sup>th</sup> Ed., AISC, Chicago, IL, USA

American Institute of Steel Construction Steel (2003) "Fire Resistance of Structural Steel Framing," Steel Design Guide 19, AISC, Chicago, IL, USA

American Society of Civil Engineers (2007) "ASCE/SEI/SFPE 29-05 Standard Calculation Methods for Structural Fire Protection," Reston, VA, USA

Bailey, C.G., White, D.S. and Moore, D.B. (2000) "The Tensile Membrane Action of Unrestrained Composite Slabs Simulated under Fire Conditions," Engineering Structures, Vol. 22, 1583-1595

Building Center of Japan (2011) "The Building Standard Law of Japan," Tokyo, Japan

Clifton, G.C. (2006) "Slab Panel Method – Design of composite steel floor systems for severe fires," 3rd Edition, HERA Report R4-131, Heavy Engineering Research Association, Manukau City, New Zealand.

Clifton, G.C. (1998) "Draft for Development: Design Procedures for the Inelastic Floor System Frame Response of Multi-Storey Steel Framed Buildings in Fully Developed Natural Fires," Technical Report R4-90-DD, Heavy Engineering Research Association, Manukau City, New Zealand

Eurocode 4: EN 1994-1-1, Dec. 2004, with corrigendum Apr. 2009 - Design of composite steel and concrete structures – Part 1-1: General rules and rules for buildings, CEN, Brussels, Belgium

Eurocode 4: EN 1994-1-2, Aug. 2005, with corrigendum Jul. 2008 - Design of composite steel and concrete structures – Part 1-2: General rules - structural fire design, CEN, Brussels, Belgium

Kodur, V.K.R. (1998) "Performance of High Strength Concrete-Filled Steel Columns Exposed to Fire," Can. J. of Civil Engg. Vol. 25, 975-981

Lane, B. (2008) "Approaches to calculating structural fire resistance," NFPA Fire Protection Handbook, 12<sup>th</sup> ed., Vol. II, Chap. 19.5, Cote, A.E. Ed. National Fire Protection Association, Quincy, MA. USA pp. 19.77-19.126

Lie, T.T. and Chabot, M. (1992) "Experimental Studies on the Fire Resistance of Hollow Steel Columns Filled with Plain Concrete," IR 611, NRCC, Ottawa, Ont.

Lie, T.T. and Kodur, V.J.R. (1996) "Fire Resistance of Steel Columns Filled with Bar-Reinforced Concrete," ASCE J. of Structural Engg. Vol. 122, No.1, 30-36

National Research Council Canada (2010) "National Building Code of Canada 2010" (NBCC), Institute of Research in Construction, Ottawa, ON, Canada

Newman, G., Robinson, J.T. and Bailey, C. (2000) "Fire Safe Design: A New Approach to Multi-Storey Steel Framed Buildings," SCI Pub. 288, Steel Construction Institute, Ascot, Berkshire, UK

Newman, G., Robinson, J.T. and Bailey, C. (2006) "Safe Design: A New Approach to Multi-Storey Steel Framed Buildings," SCI Pub. 288, 2<sup>nd</sup> ed., Steel Construction Institute, Ascot, Berkshire, UK

Oliver, S., Feeney, M., Jones, B. (2008) "Dependable Performance of Steel Structures in Fire with Case Studies," Proc. Structural Eng. Assoc. of California, 77<sup>th</sup> SEAOC Annual Convention, Big Island, Hawaii

Standards Australia (1998) "Steel structures," AS 4100-1998, Section 12: Fire, Homebush, NSW, Australia

Standards New Zealand (1997) "Steel structures standard," NZS 3404: Part 1:1997, Wellington, NZ  
(current in 2013) Chapter 11: Fire

Usmani, A.S. and Cameron, N.J.K. (2004) "Limit capacity of reinforced Concrete Floor Slabs in Fire,"  
Cement and Concrete Composites, Vol. 26, No. 2, 127-140

Uy, B. (2013) "AS/NZS 2327 Composite Structures: a new standard for composite-steel concrete  
buildings," *Steel Innovations*, Feb., Christchurch, NZ

Wang, Y.C. (1996) "Tensile Membrane Action in Slabs and its Application to the Cardington Fire Tests,"  
Proc. 2<sup>nd</sup> Cardington Conf., BRE, Cardington, UK, Mar.

Wang, Y.C. (2005) "Performance of steel-concrete composite structures in fire," *Prog. Struct. Engng.  
Mater.* **7**, 86-102, Wiley-Interscience

# Chapter 7 Prestressed Concrete Structures

## 7.1 PCI 3<sup>rd</sup> ed. 2011: Design for fire resistance of precast/prestressed concrete By the Fire Subcommittee of the Prestressed Concrete Institute Building Code Committee

The basis for the fire resistance rating of prestressed, precast members is the standard fire defined by ASTM E119. The guide provides isotherms for various cross sections at various time exposures to the standard fire, and methods for calculating the fire rating of slabs and beams under various conditions: simply supported, continuous, or with resistance to thermal expansion. The methods are similar to those used for reinforced concrete members, and are the same as for ambient temperature, but with material properties as functions of temperature (also provided by the guide). For example, the retained moment capacity  $M_{n\theta}$  at temperature  $\theta$  is:

$$M_{n\theta} = A_{ps}f_{ps\theta}(d - a_{\theta}/2)$$

where

$A_{ps}$  = area of prestressing steel;

$f_{ps\theta}$  = nominal strength of prestressing steel at temperature  $\theta$ ;

$d$  = section depth;

$a_{\theta}$  = depth of equivalent rectangular stress block at temperature  $\theta$ , determined by

$$A_{ps}f_{ps\theta} = 0.85f'_{c\theta}a_{\theta}b$$

$b$  = section width;

$f'_{c\theta}$  = compressive strength of concrete at temperature  $\theta$ . If the compressive zone is on top, as in simply supported beams and slabs, the concrete is generally cool enough that  $f'_{c\theta} \cong f'_c$ .

The PCI Manual also discusses restrained fire-resistive ratings at some length. It had been surmised that restraint boundary conditions introduced in fire tests could not be depended on in actual buildings. This assumption proved incorrect because actual buildings have shown tremendous structural redundancy in resisting thermal expansion due to fire. Thus the original ratings (obtained from tests prior to 1970) were kept intact due to the restrained test procedures. *Unrestrained* ratings can be based on the results of *restrained* fire tests, provided additional criteria are observed: when cold-drawn prestressing steel reaches a temperature of 430°C (800°F) or reinforcing steel reaches 600°C (1100°F), the member is assumed to be at the point of failure and is given an unrestrained rating for that time period. If, on the other hand, unrestrained rating is derived from unrestrained fire tests, then there is no limiting temperature on prestressing or passive reinforcement. Similarly, there is no limiting temperature for reinforcing or prestressing steel in the case of restrained rating of *slabs* based on restrained fire tests. There are, however, temperature limits for restrained rating of *beams* based on restrained tests: tension steel must not exceed on average 430°C (800°F) for cold-drawn prestressing steel or 600°C (1100°F) for reinforcing steel for beams longer than 1.22 m (4 ft) on center with a rating of 1 h or less, or

for the larger of 1 h or the first half of a rating period longer than 1 h (Table 7.1). Restraint is provided to a heated part of a floor that experiences a reduction in strength and stiffness, but is surrounded by cooler structural members that are able to anchor the development of membrane action in the heated slab.

**Table 7.1 Restrained and unrestrained fire rating based on tests**

Rating	Based on tests	Temperature limits
unrestrained	unrestrained	none
unrestrained	restrained	prestressing steel < 430°C (800°F) or reinforcing steel < 600°C (1100°F)
restrained	restrained	none for slabs; for beams longer than 1.22 m (4 ft) and for $t = t_r = \text{fire rating} \leq 1 \text{ h}$ or if $t_r > 1 \text{ h}$ , for $t = \max(1 \text{ h}, t_r/2)$ , prestressing steel < 430°C (800°F) or reinforcing steel < 600°C (1100°F)

The procedure for accounting for the thrust developed by resistance to thermal expansion for continuous beams and slabs is similar to that presented by the SFPE (Analytical methods for determining fire resistance of concrete members, by C. Fleischmann, A. Buchanan, and J. Chang, SFPE Handbook of Fire Protection Engineering, 4<sup>th</sup> Ed. 2008) referenced in Chapter 5.

## 7.2 International Building Code 2012

The IBC prescribes the minimum cover thickness for prestressed or post-tensioned tendons. Table 7.2 is an excerpt from IBC Table 721.1(1).

**Table 7.2 Minimum cover thickness - inches (mm)**

Insulation material	Structural part to be protected	Member type	Beam width	Fire resistance period				
				4 h	3h	2 h	1 h	
Carbonate, lightweight, sand lightweight and siliceous aggregate concrete	Bonded pretensioned reinforcement		Beams or girders	4 (102)	3 (76)	2.5 (64)	1.5 (38)	
			Solid slabs		2 (51)	1.5 (38)	1 (25)	
	Bonded or unbonded post-tensioned tendons	Unrestrained members	Solid slabs		2 (51)	1.5 (38)		
			Beams or girders	8 (203)	4.5 (114)	2.5 (64)	1.75 (44)	
		Restrained members	Solid slabs	>12 (305)	3 (76)	2.5 (64)	2 (51)	1.5 (38)
					1.25 (32)	1 (25)	0.75 (19)	
			Beams or girders	8 (203)	2.5 (64)	2 (51)	1.75 (44)	
				>12 (305)	2 (51)	1.75 (44)	1.5 (38)	

The minimum thickness of prestressed or precast slabs and walls for various fire rating periods is the same as for reinforced concrete members.

## 7.3 ASCE/SEI/SFPE 29-05

Besides containing some of the same tables as IBC (Table 7.2), ASCE 29-05 also specifies minimum covers for prestressed concrete beams 40 in<sup>2</sup> (26 000 mm<sup>2</sup>) or greater in area regardless of beam widths.

**Table 7.3 Minimum cover for prestressed reinforcement  
in beams 40 in<sup>2</sup> (26 000 mm<sup>2</sup>) or greater in area**

Concrete Aggregate Type	Cross Section Area in. <sup>2</sup> (10 <sup>3</sup> mm <sup>2</sup> )	Thickness in. (mm) of Cover for Fire Resistance Rating				
		1 h	1.5 h	2 h	3 h	4 h
<b>RESTRAINED</b>						
All	40–150 (26–97)	1.5 (38)	1.5 (38)	2 (51)	2.5 (64)	
Carbonate or siliceous	150–300 (97–194)	1.5 (38)	1.5 (38)	1.5 (38)	1.75 (44)	2.5 (64)
Carbonate or siliceous	>300 (194)	1.5 (38)	1.5 (38)	1.5 (38)	1.5 (38)	2 (51)
Lightweight or sand-lightweight	>150 (97)	1.5 (38)	1.5 (38)	1.5 (38)	1.5 (38)	2 (51)
<b>UNRESTRAINED</b>						
All	40–150 (26–97)	2 (51)	2.5 (64)			
Carbonate or siliceous	150–300 (97–194)	1.5 (38)	1.75 (44)	2.5 (64)		
Carbonate or siliceous	>300 (194)	1.5 (38)	1.5 (38)	2 (51)	3 (76)	4 (102)
Lightweight or sand-lightweight	>150 (97)	1.5 (38)	1.5 (38)	2 (51)	3 (76)	4 (102)

## 7.4 Eurocode 2-1-2 Design of concrete structures

Reinforced and prestressed concrete structures are treated in the same document. There is no separate methodology for prestressed concrete, however, the mechanical properties at elevated temperatures for cold-drawn tendons are listed separately from those of reinforcing bars. Based on a utilization factor of 0.7, the critical temperature is 400°C for prestressing bars and 350°C for strands and wires. (For comparison, the critical temperature is 500°C for reinforcing bars.) If no special check is made, the cover should be increased by 10 mm for prestressing bars, corresponding to a critical temperature of 400°C, and 15 mm for strands and wires, corresponding to a critical temperature of 350°C. The critical temperature determines the cover thickness required for a given duration under standard fire exposure.

## 7.5 New Zealand and Australia

**New Zealand Standards Concrete Structure Standard - Part 1: the design of concrete structures  
NZS 3101: Part 1: 2006, with amendments Aug. 2008, Chapter 4: Design for fire resistance  
Australian Standards AS 3600 - 2009 Concrete structures**

The cover should be increased by 10 mm for prestressing bars, and 15 mm for strands and wires, compared to its thickness for reinforcing bars.

## 7.6 2010 National Building Code of Canada, Division B, Appendix D, Fire Performance Rating

This Appendix prescribes minimum dimensions and cover thickness for various structural members. Table D-2.2.1.A lists the minimum thickness of reinforced and prestressed concrete floor and roof slabs, e.g., for 1 h fire resistance rating, the minimum thickness for type S concrete is 90 mm, for type N is 87 mm and for type L40S or Type L concrete is 72 mm. Slab thickness is the same, whether the reinforcement is prestressed or not. Table D-2.2.1.B gives the minimum concrete cover over reinforcement in concrete slabs, e.g., for 1 h fire resistance rating, the minimum cover for type S, N,

L40S or L concrete is 20 mm for reinforced concrete slabs, and 25 mm for prestressed concrete slabs. Table D-2.10.1 (shown here as Table 7.4) specifies the minimum cover over steel tendons in PC beams. The effect of end restraint on fire resistance is not accounted for.

**Table 7.4 Minimum thickness of concrete cover over steel tendons in prestressed concrete beams (mm)**

Type of concrete	Area of beam cm <sup>2</sup>	Fire-resistance rating						
		30 min	45 min	1 h	1.5 h	2 h	3 h	4 h
	260 to 970	25	39	50	64			
S or N	970 to 1940	25	26	39	45	64		
	Over 1940	25	26	39	39	50	77	102
L <sup>#</sup>	Over 970	25	25	25	39	50	77	102

<sup>#</sup> L is lightweight concrete in which all the aggregate is expanded slag, expanded clay, expanded shale or pumice. Concrete types S and L are defined in Table 6.2.

**CSA Standard A23.3-04 (2004) Design of concrete structures**

This standard has no specific provisions concerning fire.

**7.7 The Building Standard Law of Japan, August 2011**

This standard has no specific provisions concerning prestressed concrete structures in fire.

**7.8 Critical assessment**

All codes studied use the same methodology for prestressed concrete structures as for reinforced concrete structures. Certain parameters are changed to reflect the greater effect of elevated temperatures on prestressing steel than on reinforcing steel, such as an increase in concrete cover for the same fire resistance rating, or a lower critical temperature for strands and tendons than for reinforcing bars.

Some of the observations for reinforced concrete structures are repeated here: In the US, the PCI has a more detailed method on how to account for the axial thrust generated by resistance to thermal expansion than any method found in the Eurocode, but in several other aspects, Eurocode is more complete than US standards. These include: methods for preventing spalling, thickness of spalled layer to remove in design calculations; account for the actual degree of utilization of the concrete member in fire design; strength reduction in high-strength concrete (up to 90 MPa or 13 ksi cylinder strength) at elevated temperatures.

**References**

American Society of Civil Engineers (2007) *“ASCE/SEI/SFPE 29-05 Standard Calculation Methods for Structural Fire Protection,”* Reston, VA, USA

ASTM E119 (2012) "Standard Test Methods for Fire Tests of Building Construction and Materials," American Society for Testing and Materials, West Conshohocken, Pa  
Building Center of Japan (2011) "*The Building Standard Law of Japan*," Tokyo, Japan

Canadian Standards Association (2004) "*CSA A23.3-04 Design of Concrete Structures*," Toronto, ON, Canada

Eurocode 2 (2010) "Design of concrete structures – Part 1-2: general rules – structural fire design (includes AC 2008)," English translation of DIN EN 1992-1-2:2010-12, CEN, Brussels, Belgium

International Code Council (2012) "*International Building Code*," Chapter 7: Fire and Smoke Protection Features, Country Club Hills, IL, USA

National Research Council Canada (2010) "*National Building Code of Canada 2010*" (NBCC), Division B, Appendix D, Fire performance rating, Institute of Research in Construction, Ottawa, ON, Canada

New Zealand Standards (2006) "*NZS 3101: Concrete Structures Standard - Part 1: The Design of Concrete Structures 2006, with amendments Aug. 2008*," Chapter 4: Design for Fire Resistance, Wellington, NZ

Prestressed Concrete Institute PCI (2011) "*Design for fire resistance of precast/prestressed concrete*," 3<sup>rd</sup> ed. Chicago, IL, USA

Standards Australia (2009) "*AS 3600-2009 Concrete structures*," Sydney, NSW, Australia

# Chapter 8 Recommendations

This chapter offers recommendations about future work covering gaps in US building codes for structural design for fire.

## **8.1 Develop slab membrane tension provisions in US building codes for steel beam-concrete slab composites in fire**

Steel beam-concrete slab composites are a fairly common form of construction that has been shown (by the Cardington tests) to be more resilient under fire than first thought. Provided the slab has adequate steel reinforcement and the connections of the slab with perimeter beams can resist the required tension, tensile membrane action can develop in the slab under fire after significant deflection. In this case, secondary beams may be left unprotected, thus potentially leading to more economical fire protection. It is therefore recommended that US building codes develop slab membrane tension provisions *appropriate to US construction methods* for steel beam-concrete slab composites under fire.

## **8.2 Develop US code provisions for spalling of concrete, especially high strength concrete**

An important phenomenon to consider for concrete, especially high strength concrete, in fire is spalling, which is due to the build-up of pressure caused by the evaporation of pore water. Spalling removes the concrete cover and its insulating effect. The subsequent direct exposure of the steel reinforcement to fire is very detrimental to the fire resistance of reinforced concrete structures. Much research has been done in the US and elsewhere on this topic, and there is general agreement on causes and remedies, but these have yet to find their way into US building codes. There is a need for US building codes to include ways to design for spalling of concrete, especially high strength concrete.

## **8.3 Develop US performance code provisions for steel connections in fire**

The AISC Construction Manual (14<sup>th</sup> Ed. 2011, Appendix 4: Structural Design for Fire Conditions) contains the general structural integrity requirement that connections should be able to develop the strength of the connected members in fire or resist the forces, moments and deformations obtained by analysis of the structure under the applicable load combinations that include the design basis fire.

Further guidance is especially needed since elevated temperatures may cause new load paths to develop (e.g., development of tensile membrane action), and thermal expansion may cause gaps to close, thus potentially developing tension or compression in a connection, where none existed at ambient temperature. One promising approach is to extend to elevated temperatures the component method, whereby a joint is modeled as an assembly of rigid links and extensional springs, whose load-deformation curves represent different joint components that can be summed to represent the total joint response.

## **8.4 Improve steel stress-strain relationships at elevated temperatures in future US performance building codes**

Takagi and Deierlein (2007) have shown the importance of using the complete stress-strain curve of steel at elevated temperatures, rather than just accounting for the influence of temperature on the yield strength and modulus of elasticity. The current version of AISC (2011) 14<sup>th</sup> Ed. “*Construction Manual, Appendix 4: Structural Design for Fire Conditions*” adopts the EC3 (2005) stress-strain formulation, and recent work at NIST shows further progress. Unlike the EC3 formulation, the NIST model (Luecke et al. 2011) explicitly describes the time-dependent nature of the strength of steel at high temperature. For untested steels, it predicts the stress-strain behavior using only the measured room-temperature yield strength. On a subset of eight steels, the model predicts the stress-strain behavior slightly better than the equally complicated EC3 model. For three structural steels from the literature and not used in the development of the model, the NIST constitutive relations and the EC3 model predict stress-strain behavior with similar quality.

## **8.5 Update provisions for plate buckling strength at elevated temperatures, and asses need for revision of other design equations due to change in shape of steel stress-strain curve at elevated temperatures**

Compared with ambient temperature, the stress-strain curve of steel at elevated temperatures deviates from linearity at lower strains. This leads to lower plate buckling strength than the ultimate buckling load determined by equating the plate edge stress with yield stress (defined at 2% strain). Selamet and Garlock (2013) have shown that the direct mapping from ambient to elevated temperatures of the current equations for plate buckling strength can lead to unconservative predictions. Earlier criticisms by Takagi and Deierlein (2007, 2009) of the unconservativeness of this direct mapping in wide-flange sections led to changes in US and Canadian steel design specifications for compression and flexural members. It is recommended that the equations for plate buckling strength at elevated temperatures be updated, and a critical assessment be made of the possible need to revise other design equations due to the change in shape of the stress-strain curve at elevated temperatures. The adoption of a new stress-strain formulation similar to NIST proposal would be an additional reason for such an assessment.

## **8.6 Investigate effects of temperature gradient on simple design equations of steel and composite structures**

Many of the simple design equations in US building codes assume a uniform temperature over the entire cross section, or even over the entire length of a member. This assumption ignores the redistribution of stresses that takes place from the hotter parts of the cross section to the cooler parts, when temperatures are not uniform. As the temperature increases, the hotter parts of the section reach their limiting temperature, yield plastically, and transfer load to cooler regions, which still behave elastically. This load transfer continues until the cool regions become plastic and the member fails. Researchers have noted that thermal gradients in a column cross section can reduce the load carrying capacity for two reasons: column deformations due to uneven thermal expansion (bowing) and asymmetry in the column cross section due to uneven degradation of material properties (yield stress

and elastic modulus)( Agarwal et al. 2014). It should be noted that Eurocode 3.1-8 (2005) accounts for a temperature gradient along the beam depth for the purpose of evaluating the strength of joints.

It is recommended that US building codes include provisions to account for temperature gradients where necessary, preferably with the aid of design equations, which would obviate the need for a detailed finite-element analysis.

## **8.7 Expand scope of US code provisions for concrete-filled tube (CFT) columns**

For concrete-filled tube (CFT) columns, the US approach (ASCE /SEI/SFPE 29-05) is empirical (based on Canadian tests) and simple, but limited to the range of columns tested. US codes need to provide a method that covers column geometries beyond those tested. There is also a need for more research and standards for composite columns within a structural assembly. For CFT columns, the steel tube may experience local buckling at the ends or along the length under fire exposure. If local buckling occurs at the ends, then the column should be considered pinned, but there is no clear guidance on when that happens.

## **8.8 In US performance-based codes, develop methodology for analyzing parts of structure most affected by fire**

The building codes and standards studied all agree on the performance goals of structural design for fire. The framework of a performance-based code is also well in hand, e.g., the possibility of performing fire-structure analysis in the time, temperature, or strength domain. The need to continue to have simple prescriptive codes, and the need for consistency of newly developed performance-based codes with existing prescriptive provisions are also acknowledged in the building codes and standards studied.

The development of means, preferably simple and accurate, to achieve these performance goals continue to be the subject of active research. Most developed is the analysis of single members, both prescriptive and performance-based. Traditionally, furnace tests have provided the basis for the fire rating of single members and the prescriptive requirements to meet the rating. Single members are also simple enough that it is often possible to develop user-friendly rules that govern their behavior in fire through rational thermal and structural analyses, although nonlinear analysis can be used when needed.

The next level, analysis of part of the structure, needs further development in the US. In this analysis, a part that is most affected by the fire or of greatest interest is studied in detail, but its boundaries are assumed unaffected by the fire and the same as ambient. Finally, at the highest level, global analysis of the structure on fire takes into account all important nonlinearities in material and structural behavior, and changes in boundary conditions. The building codes studied agree on the general goals and methods, but the details depend on the individual situations to be investigated.

At present there is a shortage of simple design rules that can be used for analysis of part of the structure. The development of tensile membrane action can be considered to result from an analysis of a part of a structure, namely a slab with its surrounding frame of beams and columns.

## 8.9 Continue development of design fires and fire models

The selection of fire scenarios and design fires to be considered is a crucial step in a fire-structural analysis. Much progress has been achieved by many countries over the last several decades, based on statistics of fire loads and their dependence on building use and occupancy. Scenarios that must be considered include those that are most detrimental to the stability of the structure, and those that are most likely to occur. Probability theory and event tree analysis offer pathways to decision.

The standard fire temperature – time curves in many countries are quite similar. They are most useful for testing structural members in furnaces and comparing the effectiveness of various protection methods. Furthermore, specialized fire curves have been developed for particular situations, such as hydrocarbon fires and tunnel fires. In response to the criticism that the standard fire does not capture realistic fires, parameterized fire curves have been developed by Eurocode for compartments under flashover conditions, using physically based parameters that capture the effects of openings, fuel load, fuel geometry, compartment dimensions, etc. Research is continuing to develop formulas for situations that do not fit these parameters.

The problem with fire is that it is, in essence, a nonlinear phenomenon in its effects, with radiation a function of the 4<sup>th</sup> power of temperature. Therefore, superposition does not work, and it is necessary to investigate complete individual fire scenarios, rather than simple fire situations that can be combined, in a similar fashion to load cases that can be superposed and influence lines that can be developed for linear elastic analysis.

Great strides have been achieved in determining the fire scenarios that must be studied, whether for the evacuation of occupants, the safety of firefighters, the threat to neighboring buildings, or the stability of the structure in fire. Most of the efforts have focused on compartment fires, the conditions that lead to flashover, and the evolution of temperature for various compartment geometries, openings, and fuel loads. Building codes from various countries have adopted various empirical fire models, and it is unlikely that one fire model will emerge as a universal choice in the foreseeable future. More recently, local fires in expanses too large for flashover to occur have also been modeled. For compartment and local fires, there exist a number of software based on computational fluid dynamics, calibrated and verified by experiments, such as FDS (Fire Dynamics Simulator, McGrattan et al. 2013), that are in continuous development and can be used in a great many situations. As always in the case of powerful, general purpose tools, they require experience and judgment on the part of the users.

Much remains to be done, along the same line as previous development: expand statistics on fire loads for various building use and occupancy, in particular for fuel surface area and fuel arrangement, which are less well known than fire load density (see for example NFPA 557 (2012), described in Section 3.3 of this report); continue development of simplified fire models (e.g., the  $t^6$  model used in the Japanese Building Code 2011) for ordinary design, for post-flashover compartment fires and localized fires; develop new models that overcome some of the limitations of existing models, such as room aspect ratios; continue development of software for fire modeling; improve understanding of behavior of fire in large compartments and of localized fires near complex geometries; continue fire tests to calibrate and verify all these models; study various common structural arrangements to narrow down what the most detrimental fires are; provide guidance on how to apply the results of a design fire to structural

analysis, etc. In this last regard, several possibilities exist. For example, the New Zealand Standard (2012) recommends three modeling choices for the full burnout design fire, when all the fuel available is allowed to burn:

- a) Use a time-equivalent formula to calculate the equivalent fire severity and specify building elements with a fire resistance rating not less than the calculated fire severity;
- b) Use a parametric time versus gas temperature formula to calculate the thermal boundary conditions (time/temperature) for input to a structural response model, or
- c) Construct a heat release rate versus time curve. Then, taking into account the ventilation conditions, use a fire model or energy conservation equations to determine suitable thermal boundary conditions (time/temperature/flux) for input to a structural response model.

## References

Agarwal, A. Choe, L. and Varma, A.H. (2014) "Fire design of steel columns: effects of thermal gradients," *J. Constructional Steel Research*, Vol. 93, 107-118

American Institute of Steel Construction (2011) "*AISC Steel Construction Manual, Appendix 4: Structural Design for Fire Conditions*," 14<sup>th</sup> Ed., AISC, Chicago, IL, USA

ASCE /SEI/SFPE 29-05 (2007) "*Standard Calculation Methods for structural Fire Protection, Concrete-filled hollow steel tubes (Section 5.2.3)*," Reston, VA, USA

Building Center of Japan (2011) "*The Building Standard Law of Japan*," Tokyo, Japan

Eurocode 3 (2005) "Design of steel structures- Part 1-2: General rules - structural fire design," BS EN 1993-1-2:2005 also DIN EN 1993-1-2:2010-12, CEN, Brussels, Belgium

Eurocode 3 (2005) "Design of steel structures- Part 1-8 Design of joints," CEN, Brussels, Belgium

Luecke, W., Banovic, S.W., McColskey, J.D. (2011) "High-temperature tensile constitutive data and models for structural steels in fire," NIST Technical Note 1714, National Institute of Standards and Technology, Gaithersburg, MD 20899

McGrattan, K., Hostikka, S., McDermott, R., Floyd, J., Weinschenk, C., Overholt, K. (2013) "Fire Dynamics Simulator User's Guide, 6<sup>th</sup> ed." NIST SP 1019, National Institute of Standards and Technology, Gaithersburg, MD 20899

New Zealand Building Regulations (1992, reprinted 2012), Wellington, NZ

NFPA 557 (2012) "Standard Determination of Fire Loads for Use in Structural Fire Protection Design," National Fire Protection Association, Quincy, MA

Selamet, S. and Garlock, M. (2012). "Plate Buckling Strength of Steel Wide-Flange Sections at Elevated Temperatures." *J. Struct. Eng.*, 10.1061/(ASCE)ST.1943-541X.0000769 (Nov. 3, 2012)

Takagi, J. and Deierlein, G.G. (2007) "Strength design criteria for steel members at elevated temperatures," *Journal of Constructional Steel Research*, Elsevier, 63, 1036–1050

Takagi, J. and Deierlein, G.G. (2009) "Proposed design equations for CAN/CSA S16 Appendix K Provisions for steel members at high temperatures," Report prepared for the Canadian Institute of Steel Construction, Jan. 22