

NIST Technical Note 1757

**Summary and Conclusions of a
Workshop on “Quantifying the
Contribution of Flaming Residential
Upholstered Furniture to Fire Losses
in the United States”**

William M. Pitts

<http://dx.doi.org/10.6028/NIST.TN.1757>

NIST
National Institute of
Standards and Technology
U.S. Department of Commerce

NIST Technical Note 1757

**Summary and Conclusions of a
Workshop on “Quantifying the
Contribution of Flaming Residential
Upholstered Furniture to Fire Losses
in the United States”**

William M. Pitts
*Engineering Laboratory
Fire Research Division*

<http://dx.doi.org/10.6028/NIST.TN.1757>

September 2012



U.S. Department of Commerce
Rebecca Blank, Acting Secretary

National Institute of Standards and Technology
Patrick D. Gallagher, Under Secretary of Commerce for Standards and Technology and Director

Certain commercial entities, equipment, or materials may be identified in this document in order to describe an experimental procedure or concept adequately. Such identification is not intended to imply recommendation or endorsement by the National Institute of Standards and Technology, nor is it intended to imply that the entities, materials, or equipment are necessarily the best available for the purpose.

National Institute of Standards and Technology Technical Note 1757
Natl. Inst. Stand. Technol. Tech. Note 1757, 134 pages (September 2012)
<http://dx.doi.org/10.6028/NIST.TN.1757>
CODEN: NTNOEF

ABSTRACT

This report summarizes the presentations and discussions, lists major conclusions, and provides recommendations for specific next steps from a workshop entitled “Quantifying the Contribution of Flaming Residential Upholstered Furniture to Fire Losses in the United States” that was held at the National Institute of Standards of Technology on March 22-23, 2012. The workshop objective was “to identify approaches for quantifying the full contribution of flaming fires of modern residential upholstered furniture (RUF) to the Nation’s fire losses and, therefore, the potential for reducing these losses”. The workshop consisted of three sessions including 1) presentations by experts on RUF fire behavior and the collection and analysis of United States fire statistics (primarily the National Fire Incidence Reporting System (NFIRS)), 2) an open, wide-ranging participant discussion addressing several specific topics with the aid of facilitators, and 3) a closing session where conclusions were listed and recommendations developed for a series of actions designed to improve the quantification of fire losses due to flaming RUF with characterized levels of uncertainty. Major workshop findings included 1) fires involving flaming RUF have the potential to grow very rapidly to high release rate levels capable of threatening civilians, firefighters, and property, 2) fires involving RUF are a major factor in current fire losses in the United States, contributing at much greater levels than their numbers would indicate, and 3) existing statistical analyses likely underestimate the full contribution of flaming RUF to fire losses. An approach based on a matrix analysis is recommended to improve estimates for the contribution of flaming RUF to fire losses in the short term. In addition, a series of longer-term steps designed to improve the accuracy of these estimates and reduce uncertainties in the values are suggested. These include 1) surveys of NFIRS practitioners to better understand how specific items are coded in NFIRS, 2) organize and carry out an NFIRS special study designed to provide targeted information concerning the role of flaming RUF in residential fires, and 3) perform probabilistic fire modeling to better understand the role of flaming RUF in fire growth and spread. Appendices to the report include the workshop announcement, attendees, agenda, and PowerPoint presentations; a copy of the NFIRS coding form; and a summary and conclusions from the first day presentations and discussion.

Key Words: fire losses; fire statistics; flaming fires; NFIRS; residential fires, residential upholstered furniture; workshop

Table of Contents

ABSTRACT.....	i
Table of Contents.....	ii
1. Introduction.....	1
2. Background.....	1
3. Workshop Organization.....	2
4. Presentation Highlights.....	3
4.1. Anthony Hamins, NIST.....	3
4.2. William Pitts, NIST.....	3
4.3. Thomas Fabian, UL.....	4
4.4. Marc Janssens, SwRI.....	5
4.5. Bradley Pabody, USFA.....	7
4.6. John Hall, NFPA.....	8
4.7. David Butry, NIST.....	11
5. Open Forum Discussion.....	12
5.1. Would decreasing the rate of fire growth and heat release in an enclosure significantly reduce residential fire losses within the room of fire origin? (Facilitator: Jason Averill).....	12
5.2. Would decreasing the rate of fire growth and heat release in an enclosure significantly reduce residential fire losses at locations substantially removed from the room of fire origin? (Facilitator: Richard Gann).....	14
5.3. What are the relevant characteristics of residential fires involving flaming RUF contributing to fire losses? (Facilitator: Jason Averill).....	15
5.4. Is flaming RUF likely playing a significant role in residential fire losses? (Facilitator: Richard Gann).....	16
5.5. Is it appropriate to differentiate fire losses inside and exterior to the room of fire origin with regard to the role of RUF in Residential Fire Losses? (Facilitator: Jason Averill).....	16
5.6. Do existing fire statistics and related analyses effectively capture contribution of flaming RUF to residential fire losses?.....	17
5.7. Can existing fire statistics and extended analyses better capture contributions of flaming RUF to residential fire losses?.....	17
6. Summary of Presentations and Discussions and Identification of Approaches and Participants for Estimating Role of Flaming RUF in Fire Losses.....	18
6.1. Summary of Major Findings.....	18
6.2. Recommendations.....	19
7. Final Comments.....	22
8. Acknowledgements.....	22
9. References.....	22
APPENDIX A—Workshop Announcement.....	24
APPENDIX B—Workshop Attendees.....	27
APPENDIX C—Workshop Agenda.....	29
APPENDIX D—Presentations.....	32
APPENDIX D.1 Anthony Hamins, NIST.....	33
APPENDIX D.2 William M. Pitts, NIST.....	40
APPENDIX D.3 Thomas Fabian, UL.....	49
APPENDIX D.4 Marc Janssens, SwRI.....	57

APPENDIX D.5 Bradley Pabody, USFA.....	74
APPENDIX D.6 John Hall, NFPA	84
APPENDIX D.7 David Butry, NIST	102
APPENDIX E—NFIRS Coding Forms	110
APPENDIX F—Summary of First-Day Presentations and Discussion.....	127

1. Introduction

A workshop entitled “Quantifying the Contribution of Flaming Residential¹ Upholstered Furniture to Fire Losses in the United States” was held at the National Institute of Standards and Technology (NIST) in Gaithersburg, MD on March 22-23, 2012. This report summarizes the presentations, discussions, conclusions, and outcomes of the workshop.

2. Background

The rationale for the workshop was discussed in the announcement. This document is included in Appendix A.

Briefly, a large fraction of the residential upholstered furniture (RUF) found in existing homes is believed to be capable of supporting rapidly growing flaming fires that can achieve sufficiently high heat release rates to ignite other nearby items and in some cases can induce flashover as a single burning item. Furthermore, this potential and the large size and mass of a typical RUF item mean that these items can be the principal contributors to the size and loss impact of the entire fire, even when a different item is the first item ignited. These diverse phenomena involve every aspect of RUF fire performance, except its susceptibility to smoldering ignition. For this reason, the term “flaming RUF” will be used throughout this report to refer to the propensity for RUF fires to grow rapidly to high peak intensities and thereby result in large, damaging fires.

Indications of the potential for RUF to contribute to fire losses is available in recent studies reported by NIST [1] and Underwriters Laboratories (UL) [2]. In the NIST study, fire growth was studied in rooms furnished with articles, including RUF, typically found in today’s living rooms in order to characterize smoke detector response time and its implications for fire losses. One of the parameters characterized was the time to untenable conditions in the room. These times were compared with the results from a similar study carried out in the mid-1970s [3] and were found to have dropped from on the order of 17 min to around 3 min. Changes in the materials used in RUF construction over this period were identified as a major, though not the only, factor in this dramatic decrease. The UL study included a comparison of fires in fully furnished rooms in which the only difference was the presence of RUF articles constructed from either materials commonly found in furniture today, (flexible polyurethane (FPUF) foam covered with polyester fabric), or so-called “legacy” materials (cotton fabric over cotton batting). This investigation found that the time to flashover in the room was reduced from just over 30 min to around 4 min when the legacy RUF was replaced with RUF incorporating FPUF and the plastic fabric.

There are a number of modes in which RUF can participate in fires in residences. These include: (1) RUF is the first item ignited, and the fire begins and ends in smoldering mode. (2) RUF is the first item ignited, and the fire begins in flaming mode. (3) RUF is the first item ignited and the fire begins in smoldering mode, but transitions to flaming mode. (4) RUF is the first item ignited, but the RUF fire also serves as a flaming heat source to ignite other items. (5) RUF is the first item ignited, and the RUF fire is either the principal or only contributor to the room going to flashover. (6) RUF is not the first item ignited, but another item serves as a flaming heat source to ignite RUF.

¹ The National Fire Protection Association (NFPA) makes a distinction between “home” and “residential” fires. Homes include one- and two-family homes (including manufactured housing) and multi-family housing or apartments. Residential includes homes, but it also includes hotels and motels, dorms, residential board and care or assisted living, rooming houses, etc. Most of NFPA’s analyses, including analyses of upholstered furniture fires, refer to fires in homes and not all residential fires. Using these definitions, the workshop focus was home fires, even though the terms residential and home are used interchangeably in this report.

Statistics for the United States indicate that fires in which RUF is the item first ignited are responsible for a significant fraction of civilian fire losses (deaths, injuries, property). The most frequently cited ignition source for these fires is smoking materials, which typically ignite smoldering fires that can later transition to flaming. As a result, fire prevention efforts for RUF have focused on limiting smoldering ignition. The proposed Consumer Product Safety Commission's (CPSC) draft standard 16 CFR Part 1634 [4] is the prime example of this approach. Efforts to limit the fire growth and maximum heat release rates of flaming RUF have received far less attention. It should be noted that such standards aimed at flaming furniture have been developed for residential mattresses (16 CFR Part 1633 [5]) and commercial and institutional upholstered furniture (California Technical Bulletin 133 [6]).

The following three hypotheses listed in the workshop announcement, if true, suggest that significant reductions in fire losses would occur if the fire development rates and maximum heat release rates of RUF articles were substantially reduced. The hypotheses are:

- A decreased rate of fire development inside a residential room containing RUF increases the time available for response or escape and can result in decreased fire losses (both property and human) *inside* the room of fire origin.
- Flashover development in the room of fire origin increases production of toxic gases and smoke and the likelihood of fire spread to other areas of the residence. This increases the potential for fire losses at locations *substantially removed from* the room of fire origin.
- Reducing the fire growth rate on and limiting the maximum heat release rate of RUF to levels insufficient to generate flashover or ignite nearby furnishings would substantially reduce financial and human fire losses in the United States.

Even though the fire behavior of flaming RUF suggests that it likely makes a significant contribution to the nation's fire losses, no authoritative estimates of fire losses that include all and only the fires that we have here identified as "flaming RUF" are available. As a result, it is currently not possible to predict the potential for reducing fire losses by modifying RUF in such ways as to reduce its contribution to fire spread and growth in residences.

The workshop was organized specifically to evaluate the potential for estimating the contribution of flaming RUF to fire losses in the United States using currently available fire statistics and to identify future approaches for reducing uncertainties in such estimates.

The formal objective of the workshop was:

To identify approaches for quantifying the full contribution of flaming fires of modern RUF to the Nation's fire losses and, therefore, the potential for reducing these losses.

3. Workshop Organization

The approach adopted for the workshop was to bring together experts familiar with the collection and utilization of fire statistics, primarily the National Fire Incident Reporting System (NFIRS), and the fire behavior of flaming RUF with a goal of creating a synergy that would contribute to meeting the workshop objective. The final list of attendees is included in Appendix B of this report.

In order to prepare a foundation for later discussion, a series of presentations were solicited dealing with the fire behavior of flaming RUF and the description and use of NFIRS. The presenters and their talk titles are included as part of the workshop agenda provided in Appendix C. Note that due to a scheduling conflict, it was necessary for David Sheppard of the Bureau of Alcohol, Tobacco, Firearms and

Explosives (ATF) to withdraw from the workshop, and this presentation was not presented. The allocated time for this presentation was absorbed into the other talks and discussion.

The afternoon session on the first day of the workshop was intended to provide a wide ranging discussion of the workshop topic involving all of the participants. A series of questions designed to satisfy the Workshop objective and address various aspects of the topic are listed in Appendix C. Facilitators aided in focusing the discussions and capturing the major thoughts and ideas discussed by the workshop participants.

The final half day session of the workshop was devoted to identifying approaches for meeting the workshop objective and suggesting a path forward. Even though the agenda indicates a series of stages to accomplish this, the workshop participants concurred that sufficient consensus had been achieved during the first day that it was possible to work together and lay out an appropriate strategy without further deliberation. John Hall of the National Fire Protection Association (NFPA) led the discussion.

4. Presentation Highlights

The slides presented by the speakers are included in Appendix D. Major points from the presentations and related questions and discussion are summarized below.

4.1. Anthony Hamins, NIST

Anthony Hamins, Chief of the Fire Research Division of NIST, welcomed the workshop participants and provided an overview of NIST and the Engineering Laboratory. He emphasized the Fire Research Division's focus on measurement science and provided an indication of the breadth of the NIST research portfolio. The magnitude of the nation's fire problem and its impact on society was made clear by citing statistics on direct fire losses, both human and property, as well as indirect costs such as fire departments and insurance. The fire research efforts at NIST were discussed both in terms of a long-range vision and its current programs.

The magnitude of continuing fire losses in the United States was provided by considering statistics from 2008, which indicated that 2800 people died, 14,960 were injured, and direct property losses amounted to 16.6 billion dollars in structure fires. The importance of residential fires was emphasized, with 73 % of all reported structure fires, 92 % of civilian fire deaths, 86 % of civilian fire injuries, and 68 % of direct property losses due to such fires. The relative importance of residential upholstered furniture and mattresses to these losses was identified by noting that the numbers of deaths and injuries associated with fires when these items were reported as the item first ignited were substantially higher than when other items were identified as the first ignited.

4.2. William Pitts, NIST

William Pitts provided an overview of the workshop. As an example of the potential for RUF to be a serious fire problem, he showed heat release rate measurements and photographs from a NIST experiment in which a single sofa inside a small room (ISO 9705 [7]) was ignited with a small flame. For the initial 100 s following ignition, the fire grew slowly and remained relatively small. This was followed by a period of more rapid fire growth. Starting around 180 s, the fire grew very rapidly, reaching a peak heat release rate of 2.5 MW around 300 s. The room became filled with flames and heavy smoke. The NIST Dunes 1 [1] and Dunes 2 [3] experiments and the recent UL studies of RUF flammability [2] discussed in the Background Section above were then summarized. It was noted that the roughly three to four minutes required for the development of untenable conditions and/or flashover in these studies were consistent with the time required for the single sofa to become fully involved in the NIST experiment. A short summary of previous research on RUF flammability was provided.

Some statistics from the CPSC Proposed Rule 16 CFR Part 1634, *Standard for the Flammability of Residential Upholstered Furniture*, were summarized [4]. These indicated that during the period 2002-2004, 7800 reported residential fires, 540 civilian deaths, 870 civilian injuries, and \$250 million in property loss per year were attributed to fires in which RUF was identified as the item first ignited. Utilizing NFPA statistics for fires from 2003 [8], it was revealed that these values represented 1.9 %, 17 %, 6.2 %, and 4.1 %, respectively, of the totals for residential fires. The statistic which stands out is that the 1.9 % of total reported fires in which RUF was the item first ignited were responsible for 17 % of fire deaths in residences, but the values for injuries and property losses are also markedly higher than might be expected based simply on the percentage of fires involving RUF as the item first ignited. This provides an indication that fires involving RUF have the potential to be much more damaging than fires originating in other ways. In other words, the risks of civilian injury and death and property loss are much higher when the item first ignited is RUF.

Statistics taken from a summary compiled by the NFPA for 2010 indicated that 92 % of civilian structural fire deaths occurred in residences, the 4 % of fires starting in a living room, family room, or den were responsible for 24 % of the total civilian fire deaths, and similar enhancements in deaths, injuries, and property losses were associated with fires starting in a bedroom. [9] While not directly linked, these statistics suggest that the presence of RUF and bedding contribute to more serious fires. Smoking materials ignition of RUF or mattresses remained the leading cause of civilian fire deaths. Another interesting observation was obtained by normalizing fire losses by the number of reported fires per year and inspecting the trends over a period of time. This analysis revealed that even though the annual number of reported fires has dropped 55 % since 1980, the number of civilian fire deaths and injuries per reported fire has remained essentially constant. Over the same period the number of firefighter deaths and injuries per reported fire increased significantly, as did the average property loss per fire in normalized dollars.

The number of RUF articles in households was identified as an important parameter for understanding the role of RUF in fire losses. Statistics taken from the CPSC Proposed Rule 16 CFR Part 1634 indicate that an average residence contained four articles in the early 2000s [4]. This number is consistent with two, more recent, studies of flammable contents in residences carried out in Canada [10,11].

The purpose of the workshop, the hypotheses discussed earlier, and the workshop objective were then reviewed. The need to remain focused on the specific topic of the workshop was emphasized, since it was recognized that the general topic of RUF flammability is a wide-ranging topic of high current interest.

4.3. Thomas Fabian, UL

This presentation started with a review of fire statistics taken from a report by M. Ahrens of NFPA based on statistics from 2003-2008. [12] It was reported that 23 % of civilian fire deaths and 10 % of injuries were associated with the 4 % of reported fires that occurred in a living room, family room, or den. The percentage of reported fires and fire deaths agree well with those listed above. It was also noted that 21 % of fire deaths occurred in fires where RUF was the item first ignited. This value is somewhat higher than the value of 17 % cited above based on the CPSC work. The similarity of these statistics to those for bedroom fires was noted.

A series of experiments was performed at UL in which RUF materials, mock-ups, and actual RUF were tested. A range of materials were used with a focus on the effectiveness of fire barriers. A single fabric, two flexible polyurethane foams (FPUFs), a single polyester wrap, and eleven barriers were used. Data were presented for mock ups and actual RUF that showed that the use of a barrier significantly slowed fire growth and reduced peak heat release rates (HRRs). Comparison of mock-ups and RUF constructed with either non-fire-retarded foam or FPUF meeting the California TB 117 standard [13] showed

measurable reductions in peak HRRs for items containing foam meeting the standard, but the reductions provided only a marginal improvement in fire performance. Cone calorimeter measurements were characterized as having the capability to distinguish the fire performance of individual materials or groups of materials, but did not necessarily correlate with large scale experiments.

In a second phase of the effort, specially constructed RUF was positioned inside a room containing other identical furnishings. Three types of RUF were considered: contemporary (non-fire-retarded foam with polyester fabric and polyester wrap), contemporary with added fire barrier, and legacy (cotton batting and cotton fabric). As mentioned above, when the contemporary furniture was ignited, flashover was observed in around 4 min. These times were comparable to those observed in the NIST experiment with used furniture. When the legacy furniture was tested, the time to flashover increased to about 34 min. Replacing the polyester wrap in contemporary furniture with a cotton-based barrier increased the required time for flashover to roughly 21 min.

In recently completed experiments, the effects of replacing contemporary RUF with contemporary RUF with an added fire barrier were investigated inside structures representing a one story ranch house and a two story colonial home with an open floor plan. The tenability at locations well removed from the fire room was considered. Using a measured temperature 1.5 m above the floor, i.e., face height, of 150 °C as a criteria, the time to untenability for an upstairs room in the two story structure was increased from 303 s to 1959 s when the fire barrier was added.

A participant asked whether there would have been similar changes in smoke detector response time when the RUF was changed. The answer was that smoke detectors responded early in all fires, so that available escape times were significantly increased when the time to untenability increased.

The times quoted for the development of flashover and untenability led the audience to discuss the period required for a fire department to reach a location following an alarm. For an urban fire department, Sean DeCrane, a Battalion Chief with the Cleveland Fire Department, indicated that the average time between the receipt of an emergency call and when firemen are prepared to enter a residence is 7 min to 9 min. This period includes response (4 min to 6 min) and scene deployment (3 min to 4 min) times. Times for rural departments will generally be longer. These response times have obvious implications given the rapid fire growth observed with the contemporary upholstered furniture.

There was some discussion of the effectiveness of various barrier types as well as the effectiveness of using high loft barrier materials to replace polyester wrap. Both advantages and drawbacks of this approach were mentioned.

4.4. Marc Janssens, SwRI

This presentation described an investigation funded by the Department of Justice that is aiming to improve and characterize uncertainties associated with different approaches for predicting the burning behavior of RUF during fire reconstructions. An important point was made that the information available describing the RUF can vary considerably from cases where duplicate articles of RUF are available for testing, to cases where only small samples of materials used to construct the article are available, to cases where little or no information is available concerning the RUF article. The modeling approaches adopted for these various cases may vary considerably. For instance, if a duplicate article or sufficient materials are available, the RUF can be tested at full scale either as a duplicate article or a partial mockup in order to directly determine its burning behavior. If only small material samples are available, they can be tested in small scale apparatuses, such as the cone calorimeter or microscale combustion calorimeter, with the results used as inputs for appropriate RUF fire models. If no information is available, models for generic

RUF burning must be used. Uncertainties are expected to increase as the amount of information available concerning a RUF article decreases.

A number of existing models for flaming RUF were described. These included a model developed during the 1990s European project on Combustion Behavior of Upholstered Furniture (CBUF) [14], two simple models developed by Babrauskas during the 1980s [15], and the fire field model, known as the Fire Dynamics Simulator (FDS) [16], developed at NIST that has recently incorporated a fire spread and growth model.

A series of experiments were run to characterize the burning behavior of individual materials used in RUF as well as composites of these materials. Fire tests were run on small scale (cone calorimeter and microscale combustion calorimeter), intermediate scale (mock-ups), and full scale (RUF articles) in the open and inside a room. Material effects were investigated by considering two types of fabrics (non-fire-retarded and fire-retarded cotton) and five types of fillings (low and high density untreated FPUF, foams meeting the Cal 117 [13] and BS 5852 (Ignition Source 5) [17] standards, and polyester fiber fill). Other parameters varied included the size of the flaming ignition source (gaseous fuel flames of match size or equivalent to several sheets of burning newsprint or pool fires involving on 50 mL or 100 mL of gasoline), the ignition location (seat, lower front, and rear), and the size of the RUF article (one, two, or three seats). A fractional factorial model was used to reduce the number of experiments required.

In addition, to supplement the controlled tests described above, a number of articles of used RUF were collected in sets of two or more items. This allowed the burning behavior of individual articles inside a room to be investigated, while materials taken from the same type of item were tested with appropriate small-scale fire tests.

Intense burning was observed during experiments involving mock ups and actual RUF. The primary effect of ignition fire size was to change the period required for a fire to fully involve an item. Due to the intense burning and relative independence from ignition source, it was noted that evidence of intense burning on upholstered furniture might be interpreted by an investigator as involving the use of accelerants when none were used.

A subset of the full-scale mockup tests was part of a fractional factorial experiment. Analysis of the data from these tests resulted in the following observations:

- The HRR time profiles of 3-seat sofas are sensitive to the ignition location on the top of the seat cushions where the ignition source is applied (e.g., side versus middle).
- The type of ignition source significantly affects the ignition delay, with smaller sources resulting in longer delays.
- Peak HRR is strongly affected by the padding material. As an example, the peak HRR was significantly lower for mockups containing CAL TB 117 foam as opposed to those with non-fire-retarded foam.
- Ignition on the rear of upholstered furniture generally resulted in a shorter ignition delay, but a slower fire growth rate and lower peak HRR.

Note that the finding concerning non-fire-retarded and CAL TB 177 foams differs from the conclusion reached in the UL study, which indicated differences in fire development on items containing the two foam types were minor. The reason for the different conclusions remains unclear, even though it was suggested during discussion that the different volumes of the rooms used in the two studies could possibly provide an explanation.

Comparisons of model predictions for peak HRR with the experimental findings showed variable levels of agreement, depending on the model used. The overall best agreement was found with the simple model of Babrauskas [15]. The CBUF models also did a reasonable job, but predictions were somewhat poorer. Predictions using FDS tended to fall well below the measured values of peak HRR.

The study also evaluated the ability of two fire models (the zone model CFAST [18] and the field model FDS) to predict temperature distributions within a room given an experimental fire growth curve. Both models yielded results that agreed well with experiment.

During questioning, Janssens noted that single items of burning RUF were insufficient to induce flashover in the test room.² This conclusion seemed to be at variance with the NIST and UL experiments described above. The larger size of the SwRI room (3.7 m × 4.9 m × 2.7 m) was identified as the most likely reason for the difference.

4.5. Bradley Pabody, USFA

The presenter is the Chief of the National Fire Data Center (NFDC), which has the responsibility for developing and maintaining NFIRS. NFDC is part of the United States Fire Administration (USFA) in the Department of Homeland Security.

The presentation included an overview of the NFIRS system and the type of data collected. The system is voluntary, but over 23,000 fire departments in all 50 states participate. During 2010, over 1 million fires were logged into the system. Data is collected locally by the fire departments, forwarded to state fire offices for compilation, and then collected and collated by NFDC. The USFA collates the results and makes them available to the public through its website. The raw data are also provided to various organizations to allow additional analysis.

The system employs a standard form for inputting data. A copy of this form is included in Appendix E. NFIRS was started in 1975. Since then it has undergone five major revisions, and the current version is NFIRS 5.0 (there were 4.0 and 4.1 versions). NFIRS 5.0 has been in use since 1999. Preliminary planning is underway for the next version, NFIRS 6.0, but funding has not been approved, and no date for its introduction has been set. A number of initiatives are underway in the meantime to improve the handling and warehousing of data and improved web access and security.

NFIRS consist of 11 modules. The modules used vary with the type of incident. The modules are:

- The **Basic Module** (NFIRS–1) captures general information on every incident (or emergency call) to which the department responds.
- The **Fire Module** (NFIRS–2) is used to describe each fire incident to which the department responds.
- The **Structure Fire Module** (NFIRS–3) is used to describe each structure fire to which the department responds.
- The **Civilian Fire Casualty Module** (NFIRS–4) is used to report injuries or deaths to civilians or other emergency personnel (e.g., police officers, non-fire department/EMS personnel) that are related to a fire incident.
- The **Fire Service Casualty Module** (NFIRS–5) is used to report injuries and deaths of firefighters.

² Subsequent to the workshop, Marc Janssens reported that this conclusion was based on a criterion of flames extending from the doorway of the room. Later analysis utilizing different criteria for the onset of flashover indicated that flashover may actually have occurred in up to one third of their tests.

- The *EMS Module* (NFIRS–6) is completed by fire departments that provide emergency medical services.
- The *Hazardous Materials Module* (NFIRS–7) is completed to report spills or releases of 55 gallons or more of hazardous materials or when special HazMat actions were taken.
- The *Wildland Fire Module* (NFIRS–8) is completed to report incidents that involve wildland or vegetation fires. The module is used in lieu of the Fire Module for wildland fire incidents.
- The *Apparatus or Resources Module* (NFIRS–9), a department-use module, is completed to report data specific to each piece of apparatus that responds to an incident. It includes information that can be used to calculate response time and time out of service.
- The *Personnel Module* (NFIRS–10), a department-use module, is completed to report the same information as on the Apparatus or Resources Module, but it also provides for tracking the personnel associated with that apparatus.
- The *Arson Module* (NFIRS–11) is completed to report additional information on fires that have been coded by the department as “intentionally set.”

Additional information can also be included on the *Supplemental Form* (NFIRS–1S).

Questions and comments during the presentation revealed the following additional information. There is no obvious correlation between the quality of reports and how often a fire department prepares a report. Several comments were made concerning how variable responses by different people or fire departments filling out the forms can affect data collected by NFIRS. It is difficult to modify the forms once they have been completed. Since more serious fires often involve additional investigation, some information can be lost if the NFIRS report is not revised to include the updated findings. The question was raised concerning whether there have been studies on how well the forms are filled out. The general answer was “no,” but it was noted that studies have shown that fires with sources coded as of “unknown source” provide data similar to fires coded as “known.” It was also noted that some fire departments advocate classifying fires as “unknown” if there is any doubt at all.

The question was asked whether new items will be included in NFIRS 6.0. The answer was that this is likely. The USFA will work with fire service stakeholders, including local and state fire organizations, other federal agencies and non-governmental organizations on this task. It was pointed out that the task involves a large group of both researchers and data providers (fire departments) that must be convinced of the need for change, and this generally takes a great deal of effort and time. Contracts are used for system enhancements, and these costs must be included in the budget.

4.6. John Hall, NFPA

John Hall began his presentation by noting that data from NFIRS is crucial to the fire statistics community. Without it, there would be little knowledge of the fire situation in America. He did note that NFIRS is not designed for representativeness or randomness, like a true statistically designed survey, although NFIRS captures such a large percentage of all fires that it can be treated as statistically valid for purposes of estimating the share of fires or losses having certain defined characteristics. NFPA performs a statistical survey of fire departments, which is combined with NFIRS data to provide an improved statistical picture of fire in the country.

Numerous choices must be considered by analysts when using NFIRS data. There are questions concerning how information is coded. Examples include residential structure versus home structure and how confined fires³ are treated. As indicated earlier, very large fire incidents often involve separate

³Confined fires are those that do not spread beyond a non-combustible enclosure such as a cooking pot, chimney, or trash compactor.

investigations. Other types of data that might be used in conjunction with NFIRS include statistics related to insured fire losses and death certificates.

Certain data elements from NFIRS can be associated with particular fire characteristics. Elements which can be related to prevention of ignition and fire growth were considered during the presentation. A focus was information provided relative to RUF.

Six elements were identified that may be associated with an ignition. These include “cause of ignition” (**E₁**), “area of fire origin” (**D₁**), “heat source” (**D₂**), “equipment involved in ignition” (**F₁**), “item first ignited” (**D₃**), and “type of material first ignited” (**D₄**). Note: Bolded indices in parentheses refer to items in the “Fire” module of NFIRS (NFIRS-2). Utilizing the “item first ignited” element coded with upholstered furniture for the 2006-2010 timeframe to obtain annual estimates revealed that 6700 structure fires (2 %) were responsible for 480 civilian deaths (19 %), 840 civilian injuries (7 %), and 427 million dollars in property losses (6 %). These values were adjusted statistically using the NFPA survey of fire departments. Values in parentheses are percentages of total losses in residences. These percentages are similar to those cited earlier based on CPSC analysis, with the exception that the percentage of property losses attributed to this type of fire is 50 % higher.

When “type of material first ignited” (NFIRS-2 (**D₄**)) was considered, the code “fabric made of cotton, blend, rayon or wool” was cited in 72 % of fires and 76 % of fire deaths. An additional 14 % of fires and 15 % of deaths were attributed to “unknown fabric”. The code “Plastic-coated fabric. Includes plastic upholstery fabric and other vinyl fabrics” was only chosen in 2 % of fires and was associated with 2 % of deaths. These results were questioned by a member of the audience since many upholstery fabrics contain large fractions of polyolefin or polyester thermoplastics. The answer provided was that firefighters filling out the form would be unlikely to be able to distinguish between the various types of upholstery fabrics.

The question of how upholstered furniture is being ignited was considered by combining the elements on “item first ignited” (NFIRS-2 (**D₃**)) with “heat source” (NFIRS-2 (**D₂**)). Statistics indicate that 28 % of these fires and 58 % of the associated deaths are attributed to lighted tobacco products. A wide range of other heat sources make up the remainder, with any given type representing a fraction of 10 % or less.

Primary elements related to fire growth are “item first ignited” (NFIRS-2 (**D₃**)), which includes a check box for cases where spread “was confined to object of origin,” and “fire spread” (NFIRS-3 (**J₂**)), which provides an indication of the farthest extent of fire spread. Recorded fires that were “confined to object of origin” represented 24 % of reported fires and were responsible for 6 % of deaths. Fires that were “confined to the room of origin,” but not to the “object of origin,” contributed 34 % of fires and 25 % of fire deaths. For fires in which fire spread (NFIRS-3 (**J₂**)) extended beyond the room of origin (either coded as “confined to floor of origin,” “confined to building of origin,” or “beyond building of origin”), the corresponding values were 42 % and 69 %, respectively. Note that the latter type of fire is viewed as the best indicator that flashover took place during a fire. The important role of flashover is evident in that it occurred in less than one-half of the reported fires, but was responsible for over two-thirds of fire deaths.

The question of the contribution of RUF to fire growth was discussed in terms of the “item contributing most to flame spread” (NFIRS-3 (**K₁**)), even though no specific values were provided. It was noted that fire growth and flame spread do not necessarily refer to the same fire behavior. It was concluded that while the “fire spread” element may not represent an adequate surrogate for cases where RUF is the primary second item burning, it is the best element available in NFIRS that can provide some information with regard to this important topic.

Cross referencing the elements for cases where RUF was the “item first ignited” (NFIRS–2 (D₃)) with cases where fires extended beyond the room of origin (NFIRS–3 (J₂)) showed that 60 % of these fires started on RUF and were responsible for 72 % of the deaths outside of the room. A wide range of items, with none representing more than 6 % of the total, made up the remainder of the items first ignited.

There are a number of relevant properties concerning the burning behavior of RUF that cannot be estimated using only data collected by NFIRS. These include:

- Details of the type and composition of RUF present in residences.
- Location of ignition points on RUF.
- High-fidelity estimates of fires where RUF is the primary source of heat release, but is not the item first ignited.
- Detailed scenarios that show when upholstered furniture is ignited and how important it is to the course of the fire.

Given the limitations of NFIRS data in providing as detailed picture of how RUF burns as desired, a number of potential approaches for increasing the amount of information available were considered. The first was to modify NFIRS to improve the depth of information relevant to RUF burning behavior collected. This approach was viewed as unrealistic due to the increased data collection burden and the lack of resources available for collecting such data. The use of other potential sources of data, such as detailed investigations and court cases, is limited because they are almost certainly non-representative and non-statistical.

In the past, the NFIRS Special Study option has been used locally when additional information was required about particular aspects of fires. In such studies, one or more fire departments voluntarily collect focused information over a finite time period. NFIRS 5.0 has additional special study fields, although no National studies have been conducted using this feature due to limitations of some commercial software programs that may not contain this feature. CPSC has conducted studies in the past by asking fire departments to alert their investigators anytime a fire occurred with a particular heat source, equipment involved in ignition, or item first ignited. The workshop participants viewed a special study as a viable approach to obtain statistically valid data concerning RUF fire behavior.

Another potentially useful option is to construct probabilistic models incorporating knowledge about the prevalence and types of RUF in residences combined with models of fire behavior. Such models could provide insights concerning the contribution of RUF to fire losses.

The following provides a summary of the implications of this presentation for the workshop topic.

- For fires that spread beyond the room of origin, RUF serving as a secondary fuel package appeared to increase the number of fires in which RUF played a critical role by 69 %, as compared to only considering cases in which RUF was identified as the item first ignited.
- The number of fire deaths was apparently increased by 39 % compared to cases where RUF was only considered as the item first ignited.
- The above does not consider unclassified furniture. If the majority of such cases actually involved RUF, the increase in RUF contribution drops to 52 % for number of fires and 36 % for deaths.
- For fires with burning confined to the room but beyond the object of origin, secondary ignitions of RUF add 48 % to the number of fires and 31 % to deaths, not including unclassified furniture.

In more layman terms:

- Secondary ignitions of RUF add significantly to the number of fires and losses as compared to cases when RUF is recognized as the item first ignited.

- The quantitative increase in losses is currently subject to a fair degree of uncertainty.
- The uncertainty might be reduced through additional analysis and probabilistic modeling.

Several questions and comments were made in conjunction with this presentation. One participant wondered for cases in which RUF was a major factor in a fire loss, but was not the “item first ignited,” how likely was it to be identified as the “item contributing most to flame spread?” The speaker did not have an opinion. It was suggested that the cost of answering this question would likely be prohibitive.

The speaker was asked whether it was possible to determine the degree of human and property losses associated with fires that did not transition to flaming, e.g., ignition of a smoldering fire in RUF by a cigarette. The answer was that fire losses associated with this type of fire are very low percentages of the total losses. There was general agreement among the participants that this was the case. The implication of this conclusion is that fires that initiate as smoldering fires should be included in the totals of fires where flaming RUF plays an important role in fire losses.

The question concerning how well the fabrics identified as a “type of material first ignited” captured the actual type of fabrics involved was discussed further. The general consensus was that there is not likely to be useful information to identify the actual type of fabric (e.g., cellulosic, thermoplastic, leather, etc.) being coded.

A participant asked whether it is possible to identify whether a RUF item was only damaged or completely destroyed. The answer was that NFIRS does not provide this level of detail.

4.7. David Butry, NIST

This presentation discussed the use of NFIRS for performing economic analyses. A brief introduction to the economic theory of minimizing the sum of costs of protection and losses was provided. This analysis allows the most efficient amount of protection to be provided as long as the dependence of losses on the amount of protection is known. For any economic analysis dealing with fire, data on cost and losses are required.

The presenter provided a short introduction to the NFIRS system, before describing how such data can be used in economic analysis related to fire. NFIRS data can be used to measure the components of fire risk e.g., likelihood of fires, death, injuries and property losses, to understand factors related to ignition, e.g., item first ignited, and to understand factors related to losses, e.g., presence of smoke alarms. Information related to costs of fire protection and mitigation is more limited in NFIRS.

An example of a NIST economic analysis related to fire was provided. The goal was to describe the effectiveness of sprinklers in reducing fire deaths in single- and two-family homes and to convert the results to economic savings. A significant challenge was to isolate the effectiveness of sprinklers from confounders such as smoke alarm technology, distance to fire department, structure age, family income, family ages, etc. NFIRS fire incidence data was used to control for differences between sprinklered and non-sprinklered residences. It was demonstrated that sprinklers reduced fire deaths and associated property losses after confounding influences such as the presence or absence of smoke detectors and housing and family differences were accounted for.

The topic of RUF and NIFRS was considered next. The two items in the NFIRS fire module, “item first ignited” (NFIRS–2 (**D**₃)) and “item contributing most to flame spread” (NFIRS–3 (**K**₁)) refer directly to RUF. The second tracking item is considered only when the associated box indicating “check only if no flame spread OR if same material first ignited OR if unable to determine” is not checked. The “item first ignited” was reported 91 % of the time for reported non-confined residential fires during the 2002-2009

time frame. During this period, RUF was listed as the “item first ignited” 2 % of the time. “Item contributing most to flame spread” is not a required field and was completed for only 28 % of reported fires. Even with these limitations, RUF was identified on this item for 1 % of reported fires. This would seem to suggest that, at a minimum, RUF as a second or later item ignited made a significant contribution to fire growth in roughly half as many fires as when it was the “item first ignited.” Data for individual years indicated that this ratio remained roughly constant over the 2002-2009 time period.

Several questions were raised concerning how to interpret the data supplied by NFIRS. These include:

- Do “Item First Ignited” and “Item Contributing Most to Flame Spread” account for all (most) of the fires involving RUF?
 - Do other ways exist to identify fires involving RUF?
- Is it difficult to determine if RUF was involved?
 - Is under-reporting likely?
- Are fires that spread beyond the room of origin ‘special’ or ‘different’ than those that don’t?
 - Are there factors that affect both flame spread and the likelihood RUF is involved?
 - Are ‘bad’ fires more likely to contain an “Item Contributing Most to Flame Spread”?

The potential for performing economic analyses related to fires involving RUF was considered. One approach would be to simply report the number of fires and losses (deaths, injuries, property) where RUF was identified as having a major role. This approach has the advantage that it is straightforward to accomplish, but ignores the potential for the confounding effects of other factors. A second approach would be to develop statistical approaches which could account for confounding effects, thus establishing causal effects and providing a better understanding of RUF risks. Two downsides of this approach are that a researcher would need to develop a baseline for comparison, and the outcome would not directly provide national estimates.

During the follow-up questions a member of the audience pointed out that the initial economic model discussed can be very sensitive as to how it is mathematically described. There was also a question concerning whether or not society generally seeks to balance sum of costs of protection and losses, or if other factors may come into play. The speaker agreed that both of these questions would have to be addressed in any future economic modeling.

5. Open Forum Discussion

An open forum discussion involving all workshop attendees took place during the afternoon of the first day of the workshop. The series of questions included in the agenda (see Appendix C) were used to provide a framework for the discussion. Facilitators led the discussions. The following summarizes the major topics discussed and conclusions and suggestions that were made during the open forum.

5.1. *Would decreasing the rate of fire growth and heat release in an enclosure significantly reduce residential fire losses within the room of fire origin? (Facilitator: Jason Averill)*

Dan Gottuk of Hughes Associates asked the question, “What is significant?” The general consensus was that the answer depends on the amount of fire losses associated with this type of fire. Various statistics described above suggest a large fraction of losses occur in fires which are confined to a single room. It seems reasonable to expect that reducing the rates of fire growth and heat release would reduce these losses in a meaningful way.

John Hall of NFPA noted that NFIRS contains very little information about fire spread and growth within the room of origin. The data element “Item First Ignited” (NFIRS–2 (D₃)) indicates where initial fire development occurred, but there is little beyond this. The check box associated with “Type of material

contributing most to flame spread” can provide an indication that a fire was localized to the item first ignited, but it can also mean that the item contributing the most to flame spread was the initial item ignited or that it was not possible to identify the material contributing most to flame spread. The next indication of fire spread and growth does not occur until the fire leaves the room of origin as identified in “Fire Spread” (NFIRS–3 (J₂)). Reported property losses provide little additional detail about losses inside the room of origin. Additional information that might aid in assessing the answer to this question includes condition, activities, and proximity of people injured in such fires. Again, such information is unavailable. The lack of relevant information means that NFIRS provides little direct help in answering the posed question. It was suggested that engineering analysis combined with sensitivity analysis, of the type discussed during John Hall’s presentation, might provide some insight.

NFPA has released a report by Marty Ahrens entitled *Home Fires that Began with Upholstered Furniture* [19] which summarizes much of the NFIRS data related to fires involving RUF based on data from 2005 to 2009. Examples of information from this report include analyses indicating 18 % of the deaths involved people impaired by alcohol and/or drugs (Fig. 6 in report) and that around half of victims associated with fires started by smoking materials were found in the vicinity of the RUF (Fig. 14 in report). She noted that several types of information that could aid analyses of this type, such as at-risk populations, physical vulnerabilities of victims, and ignition behaviors of the RUF, are not available.

There was a wide ranging discussion of the effects of room characteristics on the recorded statistics. Recall that earlier experiments suggested that development of flashover with RUF burning seemed to depend on room size. Actual room sizes in residences can vary substantially. Think in terms of studio apartments compared with large living room and bedrooms in detached homes. No indication of such variations is available in NFIRS beyond type of residence. There are also uncertainties in how rooms may be coded. Many modern homes have large connected areas that can contain a kitchen, dining room, and living room, hallway, etc. These areas are essentially one single large room. Such areas are not distinguished from compartmented rooms.

The presence of medical oxygen was identified as another type of confounding variable. The role of oxygen in accelerating fires and contributing to losses is not generally captured in NFIRS. The consensus was that its contribution is likely underestimated and increasing over time.

It is clear that a great deal of information that could be useful in understanding fire spread and growth in a room containing RUF is not captured by NFIRS. One approach for obtaining this information would be through the special study option of NFIRS discussed earlier by John Hall. Marty Ahrens suggested that a one page check-box questionnaire that was carefully designed with five to ten simple questions would be appropriate. Sean DeCrane of the Cleveland Fire Department indicated that they frequently see fires involving RUF that are limited to a single room. Such fires had been responsible for several close calls during the past year. He believes that his department would be happy to participate in such a focused study. John Hall indicated that a study of this type could be performed over a period of roughly one year in cooperation with fire departments that were willing to participate. The selection of participating fire departments and the design of the research questions would need to be done carefully to ensure that the number of responses to a given question would be on the order of the hundreds required to provide meaningful statistics.

Several questions were raised above as to how specific NFIRS items are coded in the field. These questions included: What is coded as “Upholstered sofa, chair, vehicle seats” in “Item First Ignited” (NFIRS–2 (D₃)) and “Item Contributing Most to Flame Spread” (NFIRS–3 (K₁))? What is coded as “Furniture, utensils, other” in “Item First Ignited” (NFIRS–2 (D₃))? Are fires ignited on coverings or pillows coded as RUF or something else? How is “Area of fire origin” coded when there are multi-use areas connected together? What fabrics are really present when coded as “Fabric, fiber, cotton, blends,

rayon, wool, finished goods. Includes yarn and canvas. Excludes fur and silk” or “Plastic-coated fabric. Includes plastic upholstery fabric and other vinyl fabrics.” in the “Type of material first ignited” (NFIRS–2 (D₄))? These questions introduce the possibility of uncertainties in the statistical values derived from the NFIRS database.

An approach for reducing these uncertainties was discussed. It involved showing groups of fire investigators pictures of fire scenes and asking them to assign codes to specified questions based on what they observe. Such a survey might be done informally at assemblies of investigators by projecting the pictures and asking for a show of hands or more formally utilizing an internet survey. It was pointed out that such studies would not only provide important information for reducing uncertainties in fire statistics related to RUF, but would also prove valuable to developers of the next generation of NFIRS (Version 6.0).

5.2. *Would decreasing the rate of fire growth and heat release in an enclosure significantly reduce residential fire losses at locations substantially removed from the room of fire origin? (Facilitator: Richard Gann)*

It was pointed out that more than half of fire deaths and economic losses are associated with fires coded as extending beyond the room of origin in the “Fire spread” (NFIRS–3 (J₂)) item.

Marty Ahrens noted that the earlier discussion concerning open areas is relevant for this question as well.

The point was raised that, as written, the subject question does not provide an indication of whether the extended space was sealed or not. This was viewed as having an important influence on the development of untenable conditions.

Dick Gann raised the question of whether or not it was possible to develop untenable conditions outside the room of origin without involvement of RUF in the fire. There was no consensus concerning an answer.

The current version of NFIRS provides little information on the relationship of victim proximity to a fire and the likelihood of death or injury. Older data does provide some information.

The importance of fire growth rate was noted by Sean DeCrane. He noted that for a rapidly growing fire on the first floor of a multistory residence, very little time would be available for people on higher floors to escape. In this context, the findings of the most recent study at UL were reviewed. Tom Fabian reported that times to untenable conditions were increased from five minutes for fires involving contemporary furniture to 25 minutes when a fire barrier was added to the contemporary furniture. The importance of early detection in both scenarios was again noted.

John Hall noted that the discussion was pointing towards the value of scenario based modeling in understanding the role of RUF in fire losses. Marc Janssens added that appropriate modeling could greatly expand the database available for describing these types of fires.

Dick Gann suggested that a good data question for a special study would be aimed at determining how often firefighters find items of RUF still flaming when they arrive at residential fires.

Tom Fabian reiterated that the recent UL study completed in January considered tenability time at locations outside of the room and included soft furnishings in the fire loads.

Jason Averill briefly discussed a recent study on “Residential Fireground Field Experiments” which considered the effects of firefighter crew size on multiple measures of firefighter effectiveness. [20] This study found that 12 min to 13 min were required between the time of a 911 call and when water was applied to a fire. This time is comparable to the time for a slowly developing fire to reach flashover, but is much longer than the times reported above for RUF-fueled fires to develop untenable conditions. It should be mentioned that when rooms including upholstered furniture fires were burned as part of this study, measured times to untenable conditions inside the fire room varied from roughly 150 s. to 250 s.

Sean DeCrane emphasized the need to consider the burning behavior of multiple items. He again pointed out the short amount of time available for firefighters to reach a residence before conditions become untenable outside the room of fire origin.

Tom Fabian returned to the subject of rapid fire development inside the enclosure by noting that only a small fraction of upholstered items have natural fiber fabrics. This implies that ignition by small open flames is relatively simple. Fast fire growth will follow.

The question was raised of whether or not the degree of ventilation plays a role in fire growth. The group was unable to answer the question. John Hall thought that it was possible. Dick Gann pointed out that no information on ventilation in real fires is available. He noted that the discussion was related to the earlier discussion on what defines a room.

John Hall summarized the discussion by noting that it provided additional justification of the need for a focused special study on the characteristics of flaming RUF fires.

5.3. What are the relevant characteristics of residential fires involving flaming RUF contributing to fire losses? (Facilitator: Jason Averill)

Jason Averill began the discussion by asking this question: Do people in a room of fire origin die from burns and people outside the room of fire origin die from smoke inhalation? John Hall replied that the statistics cannot be broken down this way. Some additional analysis, perhaps a special study would be needed to address this question.

This led to a discussion of smoldering versus flaming. Again, it appears to be impossible to differentiate with current information available in NFIRS. Dan Gottuk reiterated that the majority of fire losses are associated with flaming fires.

At this point, John Hall suggested a change in terminology from “smoldering” versus “flaming” to “prevention” versus “mitigation.” The latter terms are based on current and possible future approaches for limiting fire losses. Current and proposed regulations for RUF are aimed primarily at preventing smoldering ignition. Future attempts to reduce the fire spread rate and maximum heat release rate of flaming RUF would be an example of mitigation once a fire was ignited.

Jason Averill pointed out that rapid fire development not only has implications for people in the residence, but also the firefighters who respond to the fire. Sean DeCrane seconded this by noting that the firefighters on the fire ground most often lose their lives as the result of cardiovascular problems or trauma associated with the fire. The probabilities of both types of event increase with fire size. He noted that a rapidly developing fire has ripple effects that increase the chances for firefighter losses.

5.4. *Is flaming RUF likely playing a significant role in residential fire losses? (Facilitator: Richard Gann)*

The discussion returned to the role of RUF in residential fire losses. Tom Fabian emphasized that RUF has always played a large role in fire losses and continues to do so. John Hall, based on his experience and discussions during the workshop, concluded that RUF as a second item ignited contributes to fire losses in meaningful way. Jason Averill questioned whether we are capturing its effect fully. The general answer was yes, but with caveats. Marty Ahrens noted that RUF is the most important “Item first ignited” in residential fire deaths. She feels that values currently derived from NFIRS may be underestimated.

5.5. *Is it appropriate to differentiate fire losses inside and exterior to the room of fire origin with regard to the role of RUF in Residential Fire Losses? (Facilitator: Jason Averill)*

Directly addressing the question posed, John Hall stated that it is possible to differentiate inside and outside the room of fire origin and that it is important to do so. He emphasized the point made earlier that it is more difficult to isolate the role of burning RUF inside a room due to the lack of data elements in NFIRS that capture fire behaviors between the ignition of “item first ignited” and fires which propagate beyond the room of origin. He once again noted that earlier versions of NFIRS included elements which could help address this limitation.

Marty Ahrens pointed out the need for the “Total square feet” (NFIRS–3 (I₄)) to be filled out. It frequently is not. This value would be useful in determining the relative roles of fires inside and outside the room of origin on fire losses.

Dick Gann recommended that fire losses inside and outside the room of fire origin continue to be differentiated. John Hall agreed, but emphasized the need for different approaches to better understand what takes place inside the room of fire origin. An NFIRS special study is one example of such an approach.

Sean DeCrane emphasized the need to understand what is meant when a fire is coded as having moved beyond the room of fire origin. He feels that there may be some ambiguity in NFIRS coding. The group recognized this as another question to be explored using the approach of polling NFIRS responders discussed earlier.

Dick Gann pointed out that there is an extensive database of fire measurements inside rooms including such parameters as temperatures, toxic gas concentrations, and radiant heat fluxes. It should be possible to get a good idea of tenability criteria using these measurements. John Hall noted that the presence of people is crucial to such analyses. Once appropriate models are developed, their outputs can be compared with the existing statistics in order to determine how accurately they are capturing real-world observations.

Marc Janssens noted that the recent experimental series at SwRI had generated data for 85 room fires spanning heat release rates from 100 kW to 3 MW. These should provide an ideal database to serve as the basis for a study of the type suggested above. Dick Gann added that he did not think many people would be left inside a room by the time a fire had reached the 100 kW level.

John Hall asked what would be the technical feasibility of carrying out such a study and would it help improve the understanding of the role of RUF in fire losses. He answered his own question in the affirmative by noting the importance of the type of fires under discussion. He felt that the modeling approach provided a viable way forward.

5.6. Do existing fire statistics and related analyses effectively capture contribution of flaming RUF to residential fire losses?

John Hall started the discussion by indicating the answer to the question is “no.” Tom Fabian asked if it was possible to provide a positive answer using existing NFIRS data. The answer was yes, with a caveat. With the existing data it is necessary to integrate over the less severe fires that do not emerge from the origin of fire room.

The discussion at this point returned to prevention versus mitigation. Mitigation refers to actions that address fires that were not prevented. Characterizing fires in this way is consistent with the way the Center for Disease Control characterizes hazards.

Dan Gottuk reiterated that flaming combustion is primarily responsible for the hazard of residential fires. Significant fire losses due to a smoldering fire alone require extraordinary circumstances. John Hall raised the counterpoint that an extended smoldering period can cause a build-up of toxic products in the vicinity of the fire so that when the fire transitions to flaming, the time required for untenable conditions to develop, near or far from the fire, will be reduced. Tom Fabian also noted that higher levels of carbon monoxide and cyanide per unit mass loss are generated during smoldering combustion. Note that mass loss rates for smoldering fires are generally orders of magnitude lower than those for flaming fires.

5.7. Can existing fire statistics and extended analyses better capture contributions of flaming RUF to residential fire losses?

John Hall indicated that the answer to this question is “yes,” but with reservations. Teasing out the role of flaming combustion will require extended approaches for analyzing the existing NFIRS data and an improved understanding of what is actually being captured in the existing data. The type of study suggested earlier in which the personnel actually generating NFIRS data are polled to better understand how various items are being coded is an example of the latter.

At this point, John Hall suggested a specific approach for analyzing NFIRS data designed to isolate the contribution of flaming RUF to fire losses. He proposed that a series of 2×2 matrices be used to assess the contribution of RUF to the various types of fire loss (deaths (NFIRS-4 (C,H)), injuries (NFIRS-4 (C,H)), and property (NFIRS-1, (G₂)) for fires “confined to room of origin” and fires which spread beyond the room of origin, (NFIRS-3 (J₂)). An example of such a matrix is shown below:

N_{yy} , N_{yn} , N_{ny} , and N_{nn} represent the amounts of losses due to fires matching (y subscript) and not

		Item First Ignited (D_3)	
		Yes	No
Item Contributing Most to Flame Spread (K_1)	Yes	N_{yy}	N_{yn}
	No	N_{ny}	N_{nn}

matching (n subscript) each cell's criteria. The matrices isolate losses where both conditions were true (N_{yy}), one condition was true (N_{yn} and N_{ny}) and neither condition was met (N_{nm}).

The total amount of losses where RUF was a primary contributor for a given type of fire loss will equal $N_{yy} + N_{yn} + N_{ny}$, while the amount of losses in fires where RUF contributed most to flame spread but was not identified as the first item ignited will equal N_{ny} . Summing together the results for fires isolated to and those spreading beyond the room of fire origin will provide the total losses associated with flaming RUF.

At this point, the discussion turned back to the potential for reducing fire losses once the actual contribution of flaming RUF to fire losses was quantified. The question was asked whether quantifying the contribution of RUF was sufficient along with the rhetorical question of whether it would not be better to just eliminate RUF as an issue. The answer was that in the absence of a realistic analysis of the actual contribution of RUF, it is not possible to estimate the effectiveness of various mitigation approaches for reducing fire losses.

Based on the presentations and discussions, the workshop participants agreed that limiting the development of flaming RUF fires provides the greatest opportunity for further reducing the nation's fire losses. In addition to the current losses associated with RUF as the "item first ignited," a significant fraction of current losses occur when RUF is the second (or higher) item ignited. For the particular case of residential fire deaths, participants estimated the annual numbers attributable to RUF as second item ignited would turn out to be in the 100s. Dan Gottuk asked how flaming RUF stacks up compared to mattresses, for which flaming behavior has now been regulated. John Hall answered that first- and second-item ignitions of RUF contribute to a comparable or larger fraction of fire losses as mattresses and bedding.

6. Summary of Presentations and Discussions and Identification of Approaches and Participants for Estimating Role of Flaming RUF in Fire Losses

The purpose of the final session of the workshop on the morning of the second day was to develop recommendations for estimating the total contribution of flaming RUF to fire losses and identifying potential organizations to perform the studies.

6.1. Summary of Major Findings

The session was opened by William Pitts, who presented a short summary of major points that were identified from the presentations and discussions on the first day. The slides used for this summary are included in Appendix F. The following conclusions are based on these slides with some additional points added:

- Recent studies confirm the potential for rapid flaming fire growth on RUF to cause significant fire losses in residences.
- Statistics show that fires involving RUF are many times more likely to result in property loss, injury, and particularly fatalities than expected based simply on their percentage of all fires.
- Times required for RUF-fueled fires to grow to dangerous levels are shorter than or on the same order as those required for fire departments to be notified and respond (implications for both human and property losses and fire fighter safety).
- Consensus that losses due to smoldering-only RUF fires are small and nearly negligible (losses occur following transition to flaming).
- Statistics suggest that flaming ignition of RUF occurs in a number of ways that in total represent a significant but not dominant source of fire losses involving RUF.
- Direct measures are not available describing RUF as a second (or higher) item ignited, but there may be approaches for estimating losses due to such burning.

- There is justification for breaking down statistics into losses inside the room of fire origin and outside the room of fire origin.
- Statistics describing the role of RUF inside the room of fire origin are somewhat limited due to a lack of information concerning fire growth within the room (events between ignition and fire leaving the room are not well captured by NFIRS).
- Statistics concerning the role of RUF on losses external to the room of fire origin appear to have a firm foundation.
- An analysis estimating the total contribution of RUF to fire losses utilizing the existing NFIRS database was suggested utilizing the matrix approach discussed on p. 16.
- Approaches for filling in some data gaps and uncertainties in NFIRS data were suggested.
 - Informal questioning of people filling out NFIRS form to clarify how coding is being performed in the field.
 - Targeted NFIRS special study using a one page data sheet.
- Probabilistic modeling of fire spread and growth in rooms based on fire experiments using existing fire models offers an approach for better understanding the role of RUF in fire losses.
- There is a continuing need for estimates of the numbers and characteristics (etc., fabric, polyurethane foam, fiber fill, barrier fabrics) of RUF items currently in residences.
- “Prevention” versus “mitigation” provides an alternate framework for discussing the contribution of RUF to fire losses.

6.2. Recommendations

As mentioned earlier, even though the workshop schedule (Appendix C) called for a systematic discussion building towards formulation of approaches for quantifying the full contribution of flaming fires of RUF to the nation’s fire losses, the participants felt that sufficient progress had been made during the first day such that only a shortened single discussion was necessary in order to formulate recommendations. John Hall of NFPA acted as the facilitator for this session.

The final recommendations of the workshop participants closely follow suggestions made during the presentations and open forum discussions.

1) Estimate fire losses (deaths, injuries, and property) utilizing the matrix approach discussed on p. 16.

The first recommendation is to use the NFIRS database to provide estimates for the annual fire deaths, injuries, and property losses in residential fires where flaming RUF played a crucial role as identified by its NFIRS coding as “Item first ignited” (NFIRS–2, (**D**₃)) and/or “Item contributing most to flame spread” (NFIRS–3, (**K**₁)). This analysis will be accomplished using the matrix approach described on p. 16. Careful attention will be paid to cases where the box in element **K** of NFIRS–3 is checked, since this element has the potential to introduce uncertainty into the analysis. The analysis will be repeated for various “Area of fire origin” (NFIRS–2, (**D**₁)) and cases where fires are “Confined to room of origin” (NFIRS–3 (**J**₂-2)) and where fires spread beyond the room of origin (NFIRS–3 (**J**₂-3, **4**, or **5**)).

Summation over all of the elements will provide overall estimates for fire losses where flaming RUF played a pivotal role. Considering individual classes will allow statistics to be broken out in terms of initial ignition condition (smoldering versus flaming), role of flashover (losses in room of origin versus losses outside of room) and location of the RUF.

Implementation of this recommendation was viewed by the practitioners as being relatively straightforward and as falling within their current duties. Researchers from NFPA and USFA committed

to performing these analyses shortly after this report becomes available. Researchers at CPSC and NIST have expertise in this area and could effectively contribute to a joint effort.

From the presentations and discussions, it became evident that while completion of Recommendation 1) will provide much improved estimates for the contribution of flaming RUF to fire losses, the values will still be subject to significant uncertainties due to questions as to how the relevant NFIRS items are being coded in the field and limitations based on the specific information that is collected by NFIRS.

Three approaches were recommended to reduce these uncertainties. The first is designed to address questions that arose as to how certain NFIRS items are coded by surveyors in the field.

2) Survey groups of people responsible for coding NFIRS forms to determine how items are coded when presented with pictures or descriptions of various conditions.

This information will be utilized to better understand what the NFIRS responses of field practitioners actually represent. The surveys could range from questioning of groups at appropriate meetings to more formal internet surveys based on email lists of people known to fill out NFIRS forms and participants in training classes at the National Fire Academy.

A number of items and responses were suggested for examination. These include:

- How are large open areas encompassing multiple uses coded? (NFIRS–2 (**D**₁), NFIRS–3 (**I**₄))?
- What types of areas are coded as “function area, other” (Item 20)? (NFIRS–2 (**D**₁), NFIRS–4 (**M**₅))?
- What range of items are identified as being “upholstered furniture” (Item 21)? (NFIRS–2 (**D**₃), NFIRS–3 (**K**₁))?
- What types of furniture are coded as “furniture, utensils, other” (Item 20)? (NFIRS–2 (**D**₃), NFIRS–3 (**K**₁))?
- How are upholstery fabrics being coded for a variety of types (Items 70 to 77)? (NFIRS–2 (**D**₄), NFIRS–3 (**K**₂))?
- What conditions result in the associated box for NFIRS–3 (**K**) being checked?
- Are fires where coverings/pillows are responsible for “Item first ignited” (NFIRS–2 (**D**₃)) or “Item contributing most of flame spread” (NFIRS–3 (**K**₁)) coded as “upholstered furniture (Item 21) or something else?
- What observations do coders use to determine that a fire has moved beyond the room of origin?
- Do respondents “observe” or “infer”?
- How often do respondents complete NFIRS forms?

Surveys of this type will not only serve to reduce uncertainties in estimates of fire losses due to RUF in residences, but will also provide valuable feedback to the NFIRS development team with regard to the current questionnaire (Version 5) as well as guidance for the development of Version 6.

Participants recognized that organizing a study of this type would represent a major undertaking requiring institutional support, significant time and financial resources, and cooperation among a variety of organizations. It was evident that such an undertaking requires additional planning and coordination between potential participating organizations. It is recommended that planning for a study of this type be started as soon as possible. Potential participants include NIST, NFPA, USFA, and CPSC, as well as organizations that can aid in identifying and obtaining cooperation of NFIRS coders to participate in the survey.

3) Organize an NFIRS Special Study Focused on RUF Fire Behavior in Room of Fire Origin

The second approach for reducing uncertainties in fire loss estimates is to utilize the NFIRS provision for special studies designed to address specific questions concerning fires recorded by the survey. The participants recommended that such a special study be designed and carried out to better understand the role of flaming RUF in the room of fire origin. As discussed earlier, the existing NFIRS database provides few insights concerning fire behavior between the time an item is ignited inside a room and the fire spreads beyond the room of origin.

It was suggested that a single page containing five to ten carefully formulated questions be developed for incorporation into the NFIRS questionnaire. This additional page would ask for observations aimed at developing a better understanding of flaming RUF behavior during residential fires. Potential points that could be addressed by the special study include:

- Specific details concerning RUF, e.g., pillow and coverings, type of upholstery fabric, size, general configuration.
- Did flaming RUF occur?
- Area of RUF burning when fire department arrived.
- Area of RUF burned when fire was extinguished.
- Where was RUF ignited?
- Were there signs of flashover in the room?
- What were the ventilation conditions in the room of origin?
- If fires were fatal, were deaths due to burns or smoke inhalation (broken out by inside and outside of room of fire origin)?

The participants felt that a one-year period would be sufficient for the study, assuming the active participation of a sufficient number of fire departments to ensure statistically meaningful samples.

The development and performance of an NFIRS Special Study is a major undertaking. As for the more informal survey discussed above, a great deal of planning and cooperation between multiple organizations would be required. The questionnaire must be developed carefully and tested prior to the study. Due to the extra burden and training associated with a Special Study, a premium is placed on identifying fire departments willing to participate in the study. The workshop participants recognized the large commitment of organizational resources would be required to make such an effort successful. Nonetheless, the participants strongly recommended that a Special Study be organized because of the unique opportunity it offers to advance the understanding of the role of flaming RUF in fire losses. Participants noted that CPSC has extensive experience in organizing NFIRS Special Studies. Additional organizations that could make invaluable contributions include USFA, NFPA, NIST, the International Association of Fire Fighters, and the International Association of Fire Chiefs.

4) Probabilistic Modeling of RUF Room Fires Incorporating Experimental Observations

The third approach identified for limiting uncertainties associated with estimates of fire losses due to flaming RUF is to combine existing model(s) of fire behavior with experimental results for the burning behaviors of RUF to investigate the role of RUF in fire spread and growth and the development of untenable conditions. This approach is designed to better understand the burning behavior of RUF inside a room of fire origin as well as the likelihood of fire spread beyond the room of origin.

Using this modeling approach, it would be possible to study the importance of key parameters over a wide range. These parameters include such intrinsic RUF properties as fire growth rate and maximum heat release rate. Properties related to the room of fire origin such as dimensions, volume, other contents, and ventilation conditions will also be varied parametrically. Some fire models include the capability to ignite

nearby items, thus it will be possible to investigate the role of RUF in igniting nearby items as well as fire spread to RUF from nearby burning items.

This type of modeling requires an extensive database of flaming RUF to serve as inputs. The recent studies from UL, SwRI, and NIST described in this report along with earlier published studies can serve as the basis for such a database. All three organizations are committed to making their experimental findings available to the research community.

The modeling effort necessary to understand the behavior of RUF in residential fires is likely to require an extended period and involve strong interactions between experimentalist and modelers. Prior to the workshop, NIST researchers had in place a plan for a scoping study designed to investigate the potential of the CFAST software [18] to provide a better understanding of the contribution of RUF to fire losses. This study will be carried out during the next few months. It should provide a good indication of what progress can be expected using this approach.

7. Final Comments

The objective of the workshop, to identify approaches for quantifying the full contribution of flaming fires of modern RUF to the nation's fire losses, was met. When the approach outlined above is fully implemented, it will provide a vastly improved quantification of the role of RUF in residential fire losses. The data generated by the study would also provide valuable input to the developers of NFIRS.

Research discussed during the workshop reinforced the widely held perception that the potential for rapid flaming fire spread and growth on RUF is likely playing a large role in current fire losses in residences and is likely the largest single factor for fire fatalities. Statistics showing the unusually high number of fire deaths associated with fires starting in rooms typically containing RUF and the high losses in fires where RUF is cited as the "Initial item ignited" and/or the "Item contributing most to flame spread," when combined with experiments showing the rapid fire spread and growth possible on contemporary RUF provide strong evidence for the important role of RUF. The implications for civilian and firefighters losses are evident.

8. Acknowledgements

The success of the workshop was the direct result of the active participation and contributions of all of the attendees. The organizers wish to thank everyone for their hard work and dedication. We recognize that every person and organization in attendance invested time and money to spend a day and a half at NIST. It is our hope that you found the workshop as useful and informative as it was for us. We look forward to working together with you and your organizations as we move forward to implement the recommendations generated formulated by the workshop participants.

9. References

- [1] R. W. Bukowski, R. D. Peacock, J. D. Averill, T. G. Cleary, N. P. Bryner, W. D. Walton, P. A. Reneke, E. D. Kuligowski, Performance of Home Smoke Alarms Analysis of the Response of Several Available Technologies in Residential Fire Settings, National Institute of Standards and Technology Technical Note 1455-1, Gaithersburg, MD, December 2007 Revision, 396 pp.
- [2] Upholstered Furniture Flammability, World Wide Web Summary of Project, <http://www.ul.com/global/eng/pages/offering/industries/buildingmaterials/fire/fireservice/upholstered/>, Underwriters Laboratories, Northbrook, IL.
- [3] R. W. Bukowski, T. E. Waterman, and W. J. Christian, Detector Sensitivity and Siting Requirement for Dwellings. Final Technical Report, National Bureau of Standards Government Contractors Report GCR 75-51, Gaithersburg, MD, 1975, 337 p.

- [4] Standard for the Flammability of Residential Upholstered Furniture; Proposed Rule, 16 CFR Part 1634, Consumer Product Safety Commission, Federal Register **71** (50), 13471-13523 (March 4, 2008).
- [5] Standard for the Flammability (Open Flame) of Mattress Sets; Final Rule, 16 CFR Part 1633, Consumer Product Safety Commission, Federal Register **73** (43), 11701-11752 (March 15, 2006).
- [6] Flammability Test Procedure for Seating Furniture for Use in Public Occupancies, State of California, Department of Consumer Affairs, Bureau of Home Furnishings and Thermal Insulation, Technical Bulletin 133, North Highlands, CA, January 1991, 29 pp.
- [7] Fire tests - Full-scale room test for surface products, International Organization for Standardization ISO 9705: 1993(E), Geneva, Switzerland, 1996.
- [8] M. J. Karter, Jr., United States fire loss for 2003, NFPA Journal, 66-71 (November/December 2004).
- [9] The U. S. Fire Problem, National Fire Protection Association, Quincy, MA, <http://www.nfpa.org/itemDetail.asp?categoryID=953&itemID=23071&URL=Research%20&%20Reports/Fire%20statistics/The%20U.S.%20fire%20problem>.
- [10] A. C. Bwalya, An extended survey of combustible contents in Canadian residential living rooms, National Research Council Canada Research Report No. 176, Ottawa, Ontario, November, 2004, 30 pp.
- [11] A. C. Bwalya, G. D. Lougheed, A. Kashef, and H. H. Saber, Survey results of combustible contents and floor areas in Canadian multi-family dwellings, National Research Council Canada Report NRCC-50593, Ottawa, Ontario, January 2010, 21 pp.
- [12] M. Ahrens, Home structure fires, National Fire Protection Association, Quincy, MA, March 2010.
- [13] Requirements, test procedure and apparatus for testing the flame retardance of resilient filling materials used in upholstered furniture, Bureau of Home Furnishings and Thermal Insulation, Technical Bulletin 117, North Highlands, CA, January 1991, 8 pp.
- [14] B. Sunström, ed., CBUF—Fire safety of upholstered furniture—the final report on the CBUF research programme, European Commission Measurements and Testing Report EUR 16477 EN, Interscience Communications Limited, London (1995).
- [15] V. Babrauskas, Upholstered furniture heat release rates—measurements and estimation, *Journal of Fire Sciences* **1**, 9–32 (1983).
- [16] K. B. McGrattan, S. Hostikka, J. E. Floyd, H. R. Baum, R. G. Rehm, Fire Dynamics Simulator (Version 5) Technical Reference Guide, National Institute of Standards and Technology Special Publication SP 1018, Gaithersburg, MD, October 2007, 100 pp.
- [17] Methods of Test for Assessment of the Ignitability of Upholstered Seating by Smouldering and Flaming Ignition Sources, British Standards Institution, BS 5852:2006, London, England, March 2006.
- [18] W. W. Jones, R. D. Peacock, G. P. Forney, P. A. Reneke, CFAST: Consolidated Model of Fire Growth and Smoke Transport (Version 6). Technical Reference Guide, SP-1026, National Institute of Standards and Technology, Gaithersburg, MD, April 2009 revision, 117 pp.
- [19] M. Ahrens, Home fires that began with upholstered furniture, National Fire Protection Association, Quincy, MA, August 2011, 94 pp.
- [20] J. D. Averill, L. Moore-Merrell, A. Barowy, R. Santos, R. Peacock, K. A. Notarianni, and D. Wissoker, Report on Residential Fireground Field Experiments, National Institute of Standards and Technology Technical Note 1661, Gaithersburg, MD, April 2010, 104 pp.

APPENDIX A—Workshop Announcement

Workshop on Quantifying the Contribution of Flaming Residential Upholstered Furniture to Fire Losses in the United States

Background. Modern residential upholstered furniture (RUF) and particularly the flexible polyurethane foam (FPUF) most often used as cushioning material are frequently cited as playing a dominant role in fire growth in residences. Fire tests have shown that modern RUF can be responsible for rapid fire growth to intense levels, especially due to the prevalence of FPUF in the cushioning. NIST showed that the burning of modern RUF led to untenable conditions in about 3 minutes. Underwriters Laboratories found similar flashover times of about 4 minutes.

Appropriately, the regulatory focus on RUF in the United States has been on scenarios that are prevalent in the compiled fire loss statistics as tracked by the National Fire Incident Reporting System (NFIRS). Since these statistics have indicated that the largest cause of fire deaths is from cigarette ignition of soft furnishings (RUF and beds), much effort has been focused on limiting *smoldering ignition*.

There has been less focus on and less success in limiting the *consequences* of flaming RUF. There are similar products whose contributions to fire hazard are regulated: 16 CFR Part 1633 caps the allowable heat release rate from residential mattresses. California TB 133 caps the allowable heat release rate from upholstered furniture for public occupancies.

A principal impediment to limiting the consequences of flaming RUF is the absence of authoritative estimates of the losses from these fires. This, despite RUF having been shown to be capable of being the principal contributor to rapid fire growth and spread in rooms, even if it is not the first item ignited. Such quantification is crucial in order to understand the potential benefits of developing and implementing approaches that effectively slow fire growth on and limit the maximum heat release rates from RUF.

This workshop is designed to identify approaches for and to stimulate efforts to develop this quantification. The results of this workshop will guide NIST research efforts and also serve to nurture cooperative efforts with members of the wider research community.

Hypotheses. The following hypotheses are provided as means for investigating and guiding efforts to quantify the contribution of RUF to residential fire losses:

- A decreased rate of fire development inside a residential room containing modern RUF increases the time available for response or escape and can result in decreased fire losses (both property and human) *inside* the room of fire origin.
- Flashover development in the room of fire origin increases production of toxic gases and smoke and the likelihood of fire spread to other areas of the residence. This increases the potential for fire losses at locations *substantially removed from* the room of fire origin.
- Reducing the fire growth rate on and limiting the maximum heat release rate of RUF to levels insufficient to generate flashover or ignite nearby furnishings would substantially reduce financial and human fire losses in the United States.

Workshop Objective. The purpose of the workshop is to identify approaches for quantifying the full contribution of flaming fires of modern RUF to the Nation's fire losses and, therefore, the potential for reducing these losses. The small group of invited participants will consist of experts in fire statistics and building fire dynamics. The program for this one-and-one-half day workshop will consist of:

- a.Short introductory presentations on fire statistics, RUF characteristics in modern American residences (including a brief overview of materials, sources, and industry practices), RUF fire

behavior, relevant structure fire dynamics, and current efforts to reduce the contribution of RUF (and mattresses) to flaming fire development.

- b. Identification of approaches for estimating the contribution of RUF flaming fire behavior to fire losses utilizing existing fire incidence data.
- c. Identification of modest additions to fire incident reports that would improve the quality of these estimates in future years.
- d. Development of an action plan for quantifying the contribution of modern RUF to the existing fire problem in the United States.

Workshop Details.

The workshop will take place over one and a half days on March 22-23, 2012 at the National Institute of Standards and Technology campus in Gaithersburg, MD. The first session will start at 8:30 a.m. on Thursday morning and we will wrap up by 4:30 p.m. A la carte lunches at your own expense will be available in the NIST cafeteria. An informal dinner will be arranged Thursday evening for those wishing to join the group. On Friday, we will once again begin at 8:30 a.m. and conclude the workshop by noon.

NIST is closed to the general public at this time. In order to attend the workshop it is necessary to pre-register. Preregistering is easy. Please email your full name and affiliation to the Fire Research Division Secretary, Wanda Duffin-Ricks (wanda.duffin-ricks@nist.gov, 301-975-6863) by **Friday, March 16th** and indicate you will be attending the Residential Upholstered Furniture workshop.

On the day of the workshop, badges can be picked up at the visitor center located at the NIST main gate at W. Diamond Ave. and Bureau Drive. Photo identification must be presented to receive your badge. Directions to NIST, site maps, and additional information are available on the WEB at www.nist.gov.

The workshop will be held in the Fire Research Division Conference Room, which is Room B245 in Building 224. To reach Building 224 from the visitor center, after passing through the guard's station you will come to a "T." Turn right onto North Drive. Take your first left onto West Drive. You will see the new NIST "Net-Zero Energy Home" on your left. Building 224 is the second general purpose laboratory building on your left after you pass the house. Ample parking is available in the lots in front of the building. Building 224 is secured and requires an employee badge for entry. You should be met at the door in the morning if you arrive on time. If you arrive and no one is present, there is a phone in the lobby which you can use to call x6863 or x6859. Someone will come to escort you in.

The closest major hotel to NIST is the Holiday Inn, Gaithersburg, located at 2 Montgomery Village Ave on the corner of North Frederick Ave and Montgomery Village Ave 1.5 miles from NIST. We have arranged a special rate of \$119/night with the Holiday Inn. Reservations may be made by calling the Hotel directly at 301/948-8900. In order to receive the special rate, you must identify your group affiliation, "NIST/Upholstered Furniture Fire Loss," at the time of the reservation. Reservations must be received by **Wednesday, March 7, 2012**. Any reservations received after the cut-off date will be accepted on a space and rate availability basis. The Holiday Inn Gaithersburg participates in the "Smoke Free" program. Smoking is not permitted in any guest rooms, restaurants, lounges, meeting rooms and public space. Should this program be violated, the Hotel reserves the right to charge a \$250.00 recovery fee. A shuttle is available to and from NIST with times to be determined.

APPENDIX B—Workshop Attendees

First Name	Last Name	Sponsor/Company	E-mail addresses	Telephone Number
Thomas	Fabian	UL	thomas.fabian@us.ul.com	847-417-5646
John	Hall	NFPA	jhall@nfpa.org	617-984-7460
Marc	Janssens	SwRI	mjanssens@swri.org	210-522-6655
Bradley	Pabody	USFA	brad.pabody@dhs.gov	301-447-1340
James	Heeschen	USFA	jim.heeschen@dhs.gov	301-447-1180
Marty	Ahrens	NFPA	mahrens@nfpa.org	617-984-7463
Bob	Luedeka	PFA	rluedeka@pfa.org	865-657-9840
David	Miller	CPSC	dmiller@cpsc.gov	301-504-7323
Douglas	Thomas	NIST	douglas.thomas@nist.gov	301-975-4918
Anthony	Hamins	NIST	anthony.hamins@nist.gov	301-875-6598
Rick	Davis	NIST	rick.davis@nist.gov	301-975-5901
Jason	Averill	NIST	averill@nist.gov	301-975-2585
Dick	Gann	NIST	rggann@nist.gov	301-975-6866
Bill	Pitts	NIST	william.pitts@nist.gov	301-975-6486
David	Butry	NIST	david.butry@nist.gov	301-975-6138
William	Grosshandler	NIST	william.grosshandler@nist.gov	301-975-6850
Chuck	Smith	CPSC	clsmith@cpsc.gov	301-504-7701
Rik	Khanna	CPSC	rkhanna@cpsc.gov	301-987-5208
Shivani	Mehta	CPSC	smehta@cpsc.gov	301-987-2025
Linda	Fansler	CPSC	lfansler@cpsc.gov	301-987-2059
Andrew	Lock	CPSC	alock@cpsc.gov	301-987-2099
Lisa	Scott	CPSC	lscott@cpsc.gov	301-987-2064
Dan	Gottuk	Hughes Associates, Inc.	dgottuk@haifire.com	410-737-8677
Sean	DeCrane	Cleveland Div. of Fire	rovloc93@aol.com	216-224-6150
Michael	Hawthorne	Chicago Tribune	mhawthorne@tribune.com	312-222-3315
Kathy	Butler	NIST	kathryn.butler@nist.gov	301-975-6673
Amanda	Robbins	NIST	amanda.robbins@nist.gov	301-975-6551
Tony	Putorti	NIST	anthony.putorti@nist.gov	301-975-8615
Nathan	Marsh	NIST	nathan.marsh@nist.gov	301-975-5441
Rick	Peacock	NIST	richard.peacock@nist.gov	301-975-6664
Bob	Chapman	NIST	robert.chapman@nist.gov	301-975-2723
Jonathan	Kent	CPSC	jkent@cpsc.gov	301-987-2485
George	Robbins	Fairfax Cty. Fire & Rescue	george.robbins@fairfaxcounty.gov	703-246-4741

APPENDIX C—Workshop Agenda

AGENDA

Workshop on Quantifying the Contribution of Flaming Residential Upholstered Furniture to Fire Losses in the United States

NIST
Building 224/Room B245
March 22-23, 2012

Thursday Morning, March 22, 2012

Background Presentations and Discussion

- 8:30 Anthony Hamins, Welcome
- 8:45 William M. Pitts, "Introduction and Background to Workshop Topic"
- 9:15 Tom Fabian, "Residential Upholstered Furniture Flammability"
- 9:45 Marc Janssens, "Reducing the Uncertainty of Quantifying the Burning Rate of Upholstered Furniture in Fire Investigations"
- 10:15 Break
- 10:30 David Sheppard, "An Investigator's View of the Role of Upholstered Furniture in Fire Scene Investigations"
- 11:00 Brad Pabody, "NFIRS Overview"
- 11:30 John Hall, "How NFPA Measures Fire Problems and Safety Strategies with Special Attention to Upholstered Furniture"
- 12:00 David Butry, "The Use of NFIRS in Economic Analysis"
- 12:30 Lunch

Thursday Afternoon, March 22, 2012

Open Forum Discussions

- 1:30 Would decreasing the rate of fire growth and heat release in an enclosure significantly reduce residential fire losses within the room of fire origin? (Leader: Jason Averill)
- 1:55 Would decreasing the rate of fire growth and heat release in an enclosure significantly reduce residential fire losses at locations substantially removed from the room of fire origin? (Leader: Richard Gann)
- 2:20 What are the relevant characteristics of residential fires involving flaming RUF contributing to fire losses? (Leader: Rick Davis)
- 2:45 Is flaming RUF likely playing a significant role in residential fire losses? (Leader: Richard Gann)
- 3:10 Break
- 3:30 Is it appropriate to differentiate fire losses inside and exterior to the room of fire origin with regard to the role of RUF in Residential Fire Losses? (Leader: Jason Averill)
- 3:55 Do existing fire statistics and related analyses effectively capture contribution of flaming RUF to residential fire losses? (Leader Rick Davis)
- 4:20 Can existing fire statistics and extended analyses better capture contributions of flaming RUF to residential fire losses? (Leader Richard Gann)
- 4:45 Summary of Presentations and Forum Discussions (William M. Pitts)

- 5:00 Adjourn
- 6:15 Dinner at Buca di Beppo Italian Restaurant, 122 Kentlands Boulevard, Gaithersburg MD 20878

Friday Morning, March 23, 2012

Identify Approaches and Participants for Estimating Role of Flaming RUF in Fire Losses

- 8:30 Brief Recap and Introduction to Session (William M. Pitts)
- 8:45 Identify Approaches for Estimating Contribution of Flaming RUF to Fire Losses within the Room of Fire Origin Using Available Fire Statistics (Leader: Jason Averill)
- 9:30 Identify Approaches for Estimating Contribution of Flaming RUF to Fire Losses at Locations Removed from the Room of Fire Origin Using Available Fire Statistics (Leader: Richard Gann)
- 10:15 Break
- 10:45 Identify Limitations in Existing Fire Statistics and Provide Suggestions for Improvement (Leader: Rick Davis)
- 11:30 Gauge Interest and Develop Working Group to Improve the Quantification of the Contribution of Flaming RUF to Residential Fire Losses (Discussion Leader: William M. Pitts)
- 12:15 Wrap-up and Final Comments (William M. Pitts)
- 12:30 Adjourn

APPENDIX D—Presentations

APPENDIX D.1 Anthony Hamins, NIST

Welcome



Workshop on Quantifying the Contribution of Flaming Residential Upholstered Furniture to Fire Losses in the United States

Anthony Hamins
March 22-23, 2012
Fire Research Division, NIST



NIST: Basic Stats and Facts

- Non-regulatory agency within the U.S. Department of Commerce
- 2800 federal employees, 2600 associates and facilities users/year
- Four labs & two centers
 - Physical Measurement Laboratory
 - Material Measurement Laboratory
 - **Engineering Laboratory**
 - Information Technology Laboratory
 - Center for Nanoscale Science and Technology
 - NIST Center for Neutron Research



Expanded National Fire Research Lab



3/20/12 site photo



Engineering Laboratory



Engineering Laboratory Mission

To promote U.S. *innovation* and *industrial competitiveness* in areas of critical national priority by **anticipating and meeting the:**

- measurement science and
- standards

needs for technology-intensive manufacturing, construction, and cyber-physical systems in ways that enhance *economic prosperity* and improve the *quality of life*.

Scope of Measurement Science

Measurement science research and services include:

- development of performance metrics, measurement and testing methods, predictive modeling and simulation tools, knowledge modeling, protocols, technical data, and reference materials and artifacts
- conduct of inter-comparison studies and calibrations
- evaluation of technologies, systems, and practices, including uncertainty analysis
- development of the technical basis for standards, codes, and practices—in many instances via testbeds, consortia, standards and codes development organizations, and/or other partnerships with industry and academia

engineering laboratory



What is the Problem?

3,320 fatalities & 16,705 injuries: Civilian
105 fatalities & 79,700 injuries: Firefighters in line of duty

Estimated 2008 U.S. Total Cost of Fire: \$362 B (2.5% GDP)#

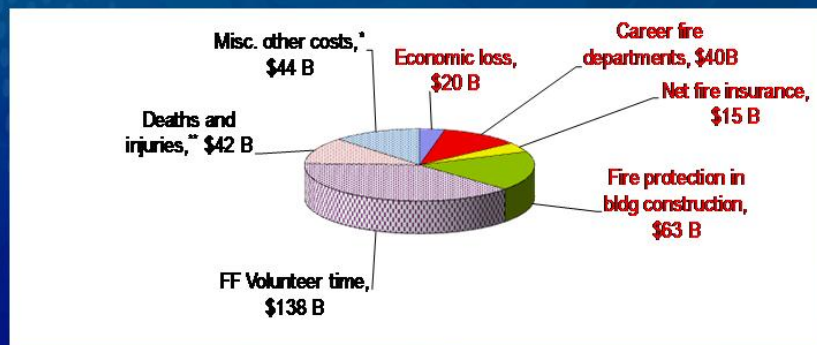

Hall, J.R., *The Total Cost of Fire in the United States*, NFPA, February 2011 (derived from USFA's NFIRS)

* industrial fire brigades, training programs, fire testing, fire retardants, maintaining/complying with product standards

** CPSC model: \$6 M/death, \$0.2 M/injury

engineering laboratory



Fire Research at NIST

Long-term vision:

Remove unwanted fire as a limitation to life safety & economic prosperity in the United States.

- Save people's lives from fires,
- Help firefighters do their jobs better and more safely,
- Reduce the economic impact of fire,
- Help save people's homes from structural fires and wildfires,
- Promote U.S. exports by furthering sound international fire safety standards,
- Advance U.S. commerce by developing & bringing fire safe products to market.

engineering laboratory



Fire Research at NIST

- Technology-centric research strategy supporting the technical basis for standards, codes, guidelines, models, software decision-tools, standard reference materials...
- Research prioritization based on:
 - Mission alignment
 - Analysis of greatest impact (problem size, potential reach)
 - Consideration of cost-effective and implementable solutions
 - Stakeholder input



materials

models

measurements

investigations

standards

engineering laboratory



Fire Research Programs

Reduced Fire Risk in Communities:

- Enable the development and implementation of advanced technologies and tactics to improve fire service safety and effectiveness
- Enable improved standards, codes, and technologies to increase the fire resistance of Wildland-Urban Interface (WUI) communities

Reduced Fire Risk in Buildings:

- Enable the manufacture of cost-effective fire-safe materials and products
- Enable effective fire protection technologies

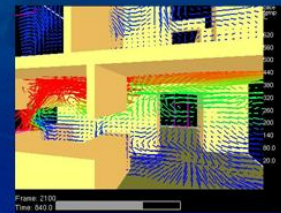
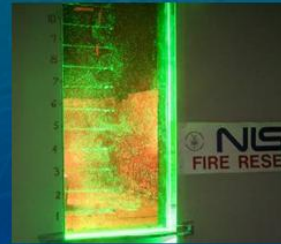

engineering laboratory



What is the Problem?

2008 Fire losses by Type (Butry/NFIRS)

Fire Type	Reported Fires	Deaths	Injuries	Property Loss (\$ B)
Structure Fires	515,000	2,900	14,960	16.6
Wildland Fires	364,000	18	257	2.8
Vehicles & Outside Fires	572,000	402	1,488	1.8
Total	1,451,000	3,320	16,705	21.2

Home fires (2005-2009) dominate structure fire losses (NFPA/NFIRS)

- 73% of all reported structure fires
- 92% of civilian structure fire deaths
- 86% of the civilian structure fire injuries
- 68% of direct structure fire property loss

engineering laboratory



What is the Problem?

First Item Ignited Fires in Residences (2003-06)*	Fires	Deaths	Injuries	Property Damage (\$ B)
Upholstered furniture	7,400	590	900	0.4
Mattress/bedding	11,200	380	1390	0.4
Thermoplastics	29,400	280	1160	0.7
Structural member, component or insulation	32,500	240	620	1.3
Other furniture or utensils	6,000	170	500	0.2
Confined cooking fire/materials	134,900	130	3670	0.3
Interior wall covering	8,200	120	340	0.3
Subtotal of Above Categories	229,600	1,910	8560	3.6
Totals	378,600	2850	13,090	6.1

* NFPA

Beyond the first item ignited, what is the total contribution of flaming residential upholstered furniture (RUF) to fire losses?



APPENDIX D.2 William M. Pitts, NIST

Introduction and Background to Workshop Topic

Workshop on

Quantifying the Contribution of Flaming Residential Upholstered Furniture to Fire Losses in the United States

NIST
March 22-23, 2012

Welcome and Thank You

Organizer: William M. Pitts

engineering laboratory



OUTLINE

1. Overview of RUF Burning Behavior
2. Overview of Selected Fire Statistics
3. Number of RUF Articles in Residences
4. Workshop
 - Background
 - Guiding Hypotheses
 - Objective
 - Organization and Schedule

engineering laboratory



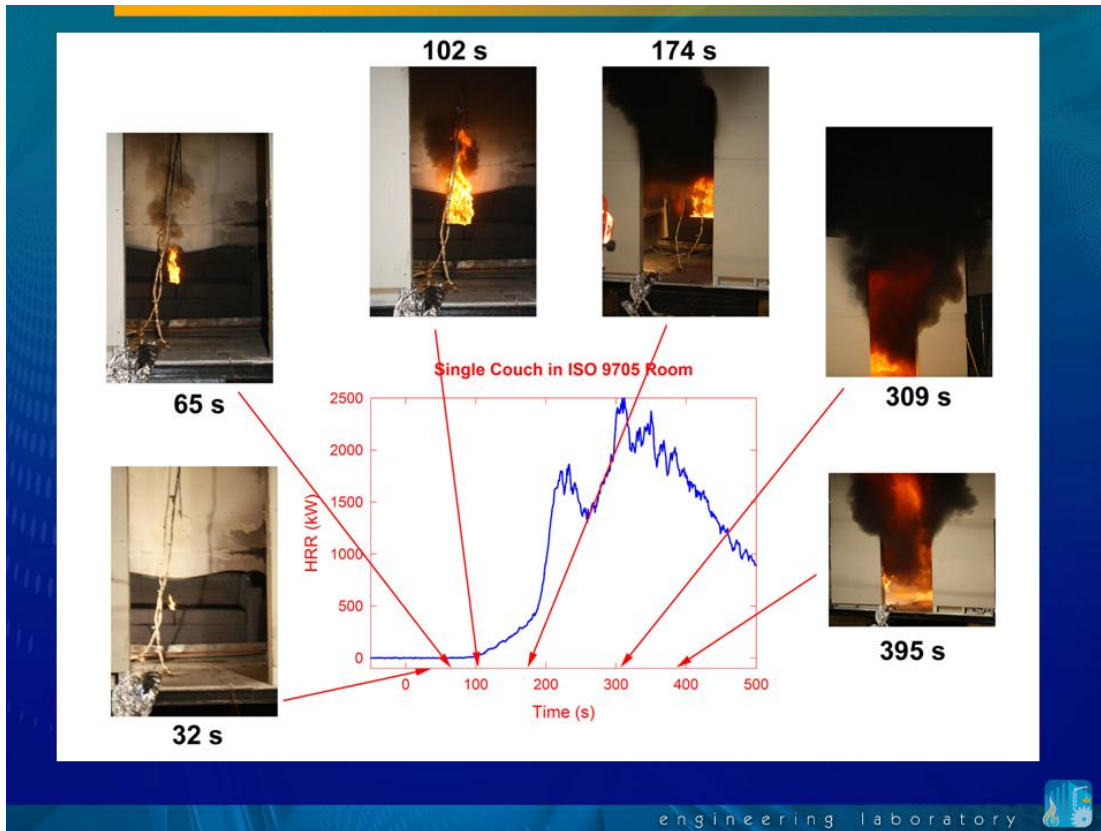

Common View of Importance of RUF to Fire Growth in Residences

“When PCFs [primary combustible furnishing] are the first-ignited item, they are known to give rise to rapidly developing fires due to the flammability of the polyurethane foam (PUF) that is the dominant combustible constituent most often used in their manufacture.”

Evidence for the Potential Impact of Rapid Fire Growth on Modern RUF on Residential Fire Losses

- The NIST Dunes II study (Bukowski et al., 2004) reported that average times required to develop untenable conditions inside a residential room were reduced from the **17 minutes** measured during Dunes I (Bukowski et al., 1975) using typical furniture from that period to the **3 minutes** identified during Dunes II (2004, 2007) utilizing modern furniture. Material changes in RUF construction over the 1975 to 2004 period was identified as a major contribution to this dramatic decrease.
- Underwriters Laboratory directly compared fire development in rooms containing RUF constructed with FPUF cushioning and microsuede fabric with rooms containing RUF produced with cotton batting cushioning and cotton fabric (chosen to represent legacy construction materials). They reported that flashover times with the legacy RUF were **34 minutes**, which were reduced to **4 minutes** when the modern materials were used.

engineering laboratory



PREVIOUS AND RECENT WORK ON FLAMING RUF

- CPSC, NIST, CBHF, BRANZ, University of Canterbury, many others
 - Years of work from 1980s onward
- CBUF – Combustion Behavior of Upholstered Furniture
 - EU Project, 1995
- Upholstered Furniture Flammability Research Study
 - UL, study of furniture flammability dependence on a range of furniture material characteristics
- Characterization of Fires in Multi-suite Residential Dwellings
 - NRC Canada, on-going, focus on development of design fires, survey of combustible contents, single-item burning in room
- Burning Rate of Upholstered Furniture
 - SwRI, focus on prediction of HRR for burning RUF for forensic analysis

engineering laboratory



Standard for the Flammability of Residential Upholstered Furniture; Proposed Rule

Consumer Product Safety Commission, 16 CFR Part 1634

Focus on Smoldering Ignition of Residential Upholstered Furniture as First Item Ignited

During period 2002–2004 upholstered furniture was the first item to ignite in an average 7,800 residential fires attended by the fire service annually compared with 402,000 fires reported in 2003 (NFPA). These fires resulted in an average of 540 deaths, 870 injuries and \$250 million in property loss each year compared with totals of 3,165 deaths, 14,075 injuries and \$6,074,000,000 in financial losses for 2003 (NFPA).

- 1.9 % of reported fires
- 17 % of fire deaths
- 6.2 % of injuries
- 4.1 % of property losses

engineering laboratory



2010 Fire Profile from NFPA

- Fire departments responded to 369,500 home structure fires which resulted in 13,350 civilian injuries, 2,640 civilian deaths, and \$6.9 billion in direct damage.
- 92% of all civilian structure fire deaths resulted from home structure fires.
- Kitchens are the leading area of origin for home structure fires (37%) and civilian home fire injuries (36%).
- Only 4% of home fires started in the living room, family room, or den; these fires caused 24% of home fire deaths.
- 8% of reported home fires started in the bedroom. These fires caused 25% of home fire deaths, 21% of home fire injuries, and 14% of the direct property damage.
- Smoking is a leading cause of civilian home fire deaths.
- Almost two-thirds (62%) of reported home fire deaths resulted from fires in homes with no smoke alarms or no working smoke alarms.

engineering laboratory



Fire losses (2008) *

Year	Reported Fires	Civilian Deaths	Civilian Injuries	Firefighter Deaths	Firefighter Injuries	Core Cost of Fire (\$ B In 2008 dollars)
1980	3,000,000	6,505	30,200	138	98,070	\$74
1990	2,250,000	5,195	28,600	108	100,300	\$86
2000	1,750,000	4,045	22,350	103	84,550	\$102
2008	1,349,000	3,320	16,705	105	79,700	\$138

Normalized Fire losses (2008) *

Year	Reported Fires/1000 people	Civilian Deaths/1000 fires	Civilian Injuries/1000 fires	Firefighter Deaths/1000 fires	Firefighter Injuries/1000 fires	Core Cost of Fire per capita (In 2008 dollars)
1980	13.2	2.2	10.1	0.46	32.7	\$326
1990	9.0	2.3	12.7	0.48	44.6	\$344
2000	6.2	2.3	12.8	0.59	48.3	\$382
2008	4.8	2.3	11.5	0.72	54.9	\$454

* Statistics derived from analysis of 2008 USFA fire statistics published by NFPA



TV Room #1



TV Room #2



Basement Bedroom

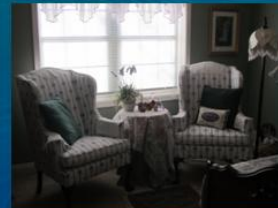

Recreation Room #1



Recreation Room #2



Master Bedroom

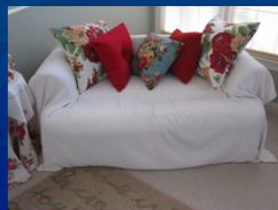

Family Room



Living Room



17 Articles in 6 Rooms



Upholstered Furniture (CPSC Proposed Rule 16 CFR Part 1634)

Furniture articles primarily intended for indoor use in residences; constructed with an upholstered seating area, comprised of a contiguous upholstered seat and back or arm(s)

Based on the assumption that the expected life of a piece of upholstered furniture is 16 years, the average number of upholstered items in household use during 2002–2004 was about 447 million pieces

Number of households in US in 2003 was 111 million (US census)

Four pieces of RUF per household



CANADIAN FUEL LOAD SURVEYS

Bwalya et al. (NRCC-50593)

Table 7. Fire load densities for various rooms

Room	Mean	Standard	95 th	Sample	Mean FL (MJ)
	FLD	Deviation	Percentile		
	(MJ/m ²)	(MJ/m ²)		Size	
Kitchen	807	123	940	515	7,908 (2)*
Secondary bedroom	594	146	846	129	6,237 (5)
Primary Bedroom	534	125	753	347	8,864 (1)
Living Room	412	127	610	397	7,251 (3)
Dining Room	393	132	576	292	3,812 (6)
Basement Living Room	288	96	450	130	6,682 (4)

* FL ranking FLD: Fire load density; FL: Total fire load

Table 9. Composition of the fire load

Room	Percent Weight		
	W	P	T
Kitchen	86.5	13.5	<<1%
Living Room	65.8	32.9	1.4
Dining Room	72.6	26.6	0.8
Primary Bedroom	42.3	26.4	31.4
Secondary bedroom	39.8	29.8	30.3
Basement Living Room	61.0	39.0	0.2

W: Wood and paper; P: Plastic materials (including PUF);
T: Textiles (including clothing); <<1%: much lower than 1%

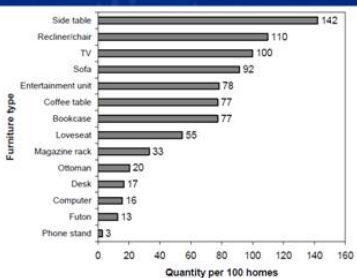

Figure 5. Number of typical types of furniture per 100 homes

Bwalya (An Extended Survey of Combustible Contents in Canadian Residential Living Rooms, NRCC Research Report No. 176)

Works out to 2.9 RUF articles per room



WORKSHOP BACKGROUND

- RUF is widely regarded as playing a central role in fire losses due to rapid fire growth and high heat content
- Existing approaches seek to limit ignition, primarily by smoldering sources, e.g., CPSC 16 CFR 1634, UFAC, NFPA 260
- Fire hazard on RUF, once ignited, is not controlled
 - Statistics focus on RUF as first item ignited
 - Contribution of flaming combustion to flashover development not quantified
 - Few efforts in US to limit RUF HRR (contrast with BS5852, CPSC 1633 for mattresses)

engineering laboratory



HYPOTHESES

- A decreased rate of fire development inside a residential room containing modern RUF increases the time available for response or escape and can result in decreased fire losses (both property and human) *inside* the room of fire origin.
- Flashover development in the room of fire origin increases production of toxic gases and smoke and the likelihood of fire spread to other areas of the residence. This increases the potential for fire losses at locations *substantially removed from* the room of fire origin.
- Reducing the fire growth rate on and limiting the maximum heat release rate of RUF to levels insufficient to generate flashover or ignite nearby furnishings would substantially reduce financial and human fire losses in the United States.

engineering laboratory



Workshop Objective

To identify approaches for quantifying the full contribution of flaming fires of modern RUF to the Nation's fire losses and, therefore, the potential for reducing these losses.

Keep in Mind!!

Furniture Flammability is a broad topic with many facets. We are all aware of the intense interest in the broad topic, but, please remember, this is **not** a workshop on furniture flammability. The burning behaviors of the existing furniture stock and residential fires are necessarily incorporated to aid in identifying means for estimating the contribution of flaming RUF to fire losses. The workshop topic is complex and all of the time available will be required to adequately address it. Try to limit your deliberations to this topic. If necessary, moderators will attempt to redirect discussions back on topic. Please be understanding.

engineering laboratory



WORKSHOP ORGANIZATION

This Morning

- Background Talks
 - RUF Burning Behavior: Fabian, Janssens, xxxx
 - Fire Statistics: Pabody, Hall, Butry

This Afternoon

- Open Forum Discussions
 - Leaders: Averill, Gann, Davis

Tomorrow Morning

- Identify Approaches and Participants for Estimating Role of Flaming RUF in Fire Losses
 - Leaders: Averill, Gann, Davis, Pitts

engineering laboratory



APPENDIX D.3 Thomas Fabian, UL

Residential Upholstered Furniture Flammability



Residential Upholstered Furniture Flammability

NIST Flaming Residential Upholstered Furniture Workshop
March 22, 2012
Gaithersburg, MD

Thomas Fabian, Ph.D.
Underwriters Laboratories

© 2012 UL LLC

Leading areas of origin in USA Home Structure Fires: 2003-2007



Fact: 21% of home fire deaths resulted from fires beginning with upholstered furniture.

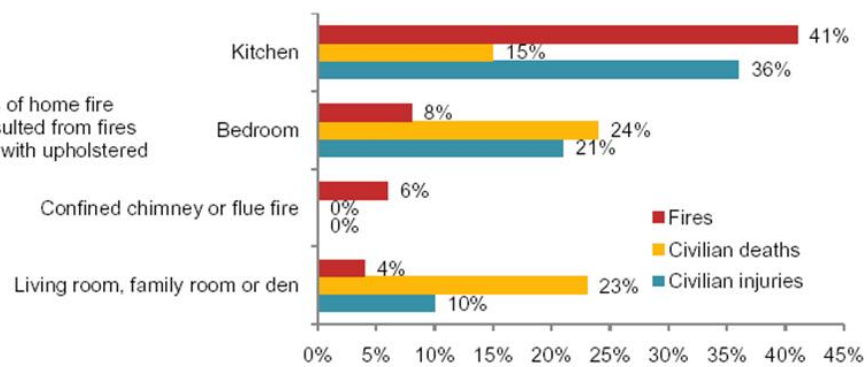

- M Ahrens, "Home Structure Fires", NFPA, March 2010



Copyright © 2012 UL LLC. All rights reserved. No portion of this material may be reprinted in any form without the express written permission of UL LLC or as otherwise provided in writing.

2

Upholstered Furniture Flammability

“Demonstration of Concept” to verify if commercially available fire resistance technologies can retard and/or reduce fire growth

3 Scales of Testing

- Material
- Mock-up
- Full chairs

www.ul.com/FireService



Copyright© 2012 UL LLC. All rights reserved. No portion of this material may be reprinted in any form without the express written permission of UL LLC or as otherwise provided in writing.

3

Upholstered Furniture Flammability Materials

Cover Fabric (1)

- Beige, polyester microsuede

Commercially available materials

Foam (2)

- Polyurethane foam ($29.6 \pm 0.6 \text{ kg/m}^3$)
- TB117 Fire retardant polyurethane foam ($27.6 \pm 0.6 \text{ kg/m}^3$)

Polyester Wrap (1)

- Polyester wrap (1 oz smooth bond)

Fire Barrier (11)

Chemistries: para-aramids, cotton, rayon, blends, and elastic

Physical form: flat/high-loft, woven/non-wovens, plain weave/knits, single/multi-layer



Copyright© 2012 UL LLC. All rights reserved. No portion of this material may be reprinted in any form without the express written permission of UL LLC or as otherwise provided in writing.

4

Upholstered Furniture Flammability Mock-up Level Tests: PU-W-C vs. PU-W-FB1-C

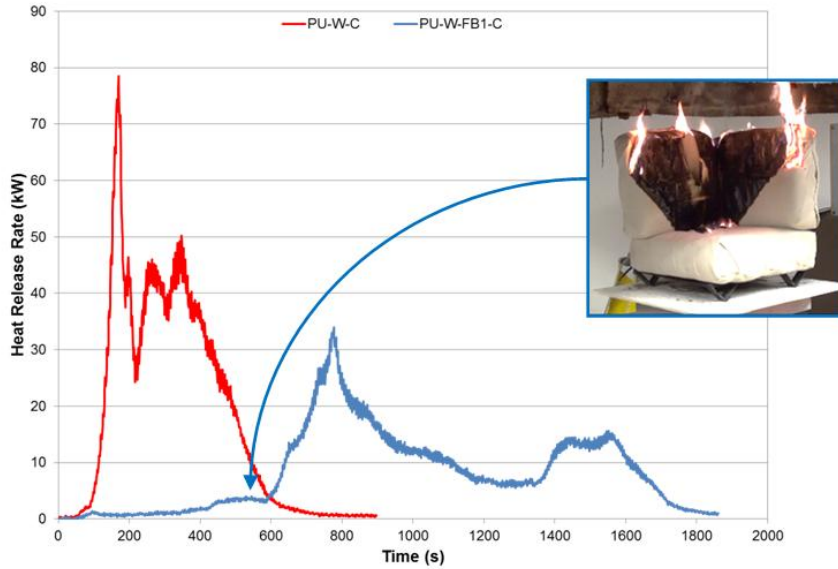

Copyright© 2012 UL LLC. All rights reserved. No portion of this material may be reprinted in any form without the express written permission of UL LLC or as otherwise provided in writing.

5

Upholstered Furniture Flammability Furniture Tests

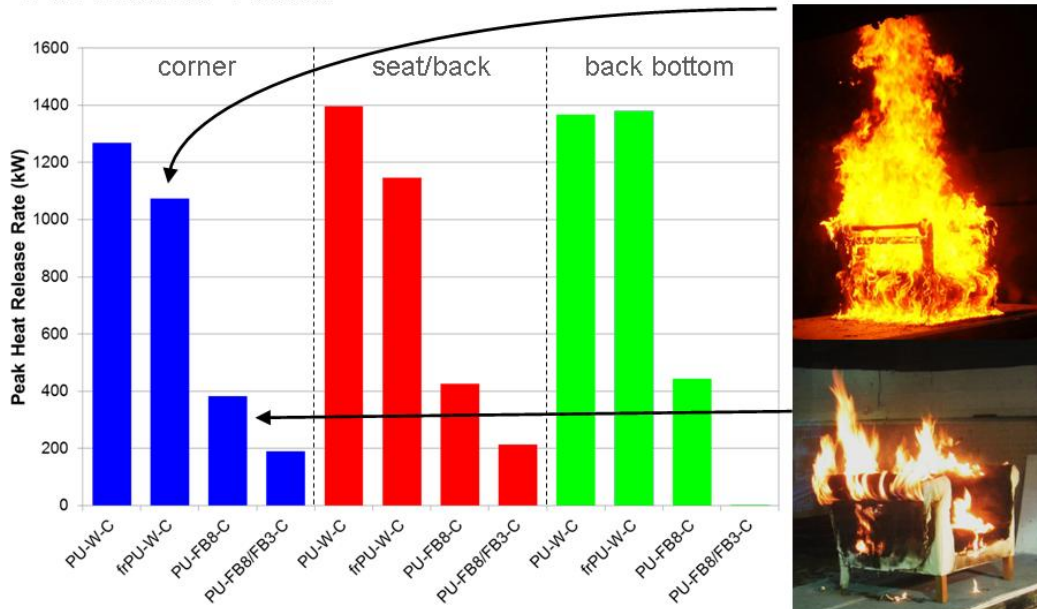

Copyright© 2012 UL LLC. All rights reserved. No portion of this material may be reprinted in any form without the express written permission of UL LLC or as otherwise provided in writing.

14

Upholstered Furniture Flammability Mitigation Summary

All approaches exhibited some level of reduced ignitability/flammability.

Approach 1: TB117 FR foam substitution for PU foam

- Reduced burn duration on cone calorimeter tests
- Reduced HRR on mock-up tests
- Reduced furniture PHRR when cushions were ignited (1.3 vs. 1.1 MW)

Approach 2: FR barrier inclusion or poly-wrap substitution

- Reduced HRR on cone calorimeter and mock-up tests
- FR barrier substitution for poly-wrap reduced furniture PHRR by ~3X

Approach 3: FR barrier substitution for poly-wrap + covered sides

- Reduced PHRR from 1+ MW to 200 kW
- Ignition of back did not propagate



Copyright© 2012 UL LLC. All rights reserved. No portion of this material may be reprinted in any form without the express written permission of UL LLC or as otherwise provided in writing.

7

Upholstered Furniture Flammability Project Test Summary

Cone calorimeter tests are “simple” tests that differentiated the combustibility of individual materials and combinations of materials.

⇒ Potential for material substitution tests

Mock-up level calorimeter tests increased sample complexity and subsequent combustion behavior by virtue of larger sample size, 3 dimensional geometry, and construction elements such as seams.

⇒ Potential for subordinate design tests

Full-scale furniture calorimeter tests further increase sample complexity and subsequent combustion behavior by virtue of larger sample size and furniture design.

⇒ End product evaluation tests



Copyright© 2012 UL LLC. All rights reserved. No portion of this material may be reprinted in any form without the express written permission of UL LLC or as otherwise provided in writing.

8

Upholstered Furniture Flammability

Phase 2: Living Room Fire Experiments

How does fire growth initiated on upholstered furniture using commercially available fire resistance technology compare to legacy and contemporary furniture?

3 Furniture Variations

- Contemporary
- Contemporary w/ barrier
- Legacy

www.ul.com/FireService



Copyright© 2012 UL LLC. All rights reserved. No portion of this material may be reprinted in any form without the express written permission of UL LLC or as otherwise provided in writing.

9

Living Room Fire Tests: Summary

- “Modern” upholstered furniture has reduced time to flashover by 30 minutes (34+ vs. 4+ minutes)
- Replacing the polyester wrap around foam (cushions, arms) with a cotton-based FR barrier (green?) lengthened time to flashover from 4+ minutes to 21+ minutes
 - ⇒ Minimal impact on furniture construction process
- Further improvement could be made by encasing the upholstered furniture frame with flat barrier
 - ⇒ Some impact on furniture construction process



Copyright© 2012 UL LLC. All rights reserved. No portion of this material may be reprinted in any form without the express written permission of UL LLC or as otherwise provided in writing.

10

Upholstered Furniture Flammability Phase 3: Tenability Experiments

What is the impact of upholstered furniture on tenability and safe egress time?

2 Furniture Variations

- Contemporary
- Contemporary w/ barrier

2 Residential Structures

- 1,200 ft² ranch
- 3,200 ft² open floor 2 story



Copyright© 2012 UL LLC. All rights reserved. No portion of this material may be reprinted in any form without the express written permission of UL LLC or as otherwise provided in writing.

11

Upholstered Furniture Flammability Phase 3: Tenability Experiments

303 seconds to 150 °C



no barrier

1959 seconds to 150 °C



with barrier



Copyright© 2012 UL LLC. All rights reserved. No portion of this material may be reprinted in any form without the express written permission of UL LLC or as otherwise provided in writing.

12

Questions and Discussion

Thomas.Fabian@us.ul.com

<http://www.ul.com/fireservice>

Upholstered Furniture Flammability Furniture Tests

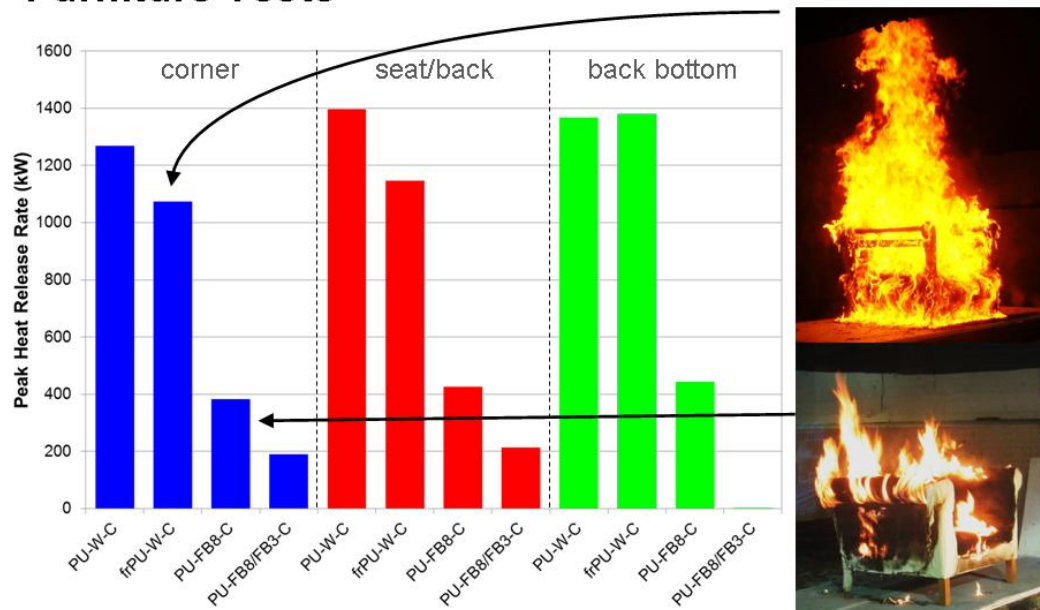

Copyright © 2012 UL LLC. All rights reserved. No portion of this material may be reprinted in any form without the express written permission of UL LLC or as otherwise provided in writing.

APPENDIX D.4 Marc Janssens, SwRI

Reducing the Uncertainty of Quantifying the Burning
Rate of Upholstered Furniture in Fire Investigations

Reducing the Uncertainty of Quantifying the Burning Rate of Upholstered Furniture in Fire Investigations



Marc L. Janssens, PhD, FSFPE
Senior Engineer
Southwest Research Institute
6220 Culebra Road, San Antonio, TX

DISCLAIMER

The following presentation summarizes partial results from SwRI Project No. 15998. This project is supported by Award No. 2010DN-UX-K221, awarded by the National Institute of Justice, Office of Justice Programs, U.S. Department of Justice. The opinions, findings, and conclusions or recommendations expressed in this presentation are those of the author and do not necessarily reflect those of the Department of Justice.



OUTLINE

- Introduction
- Methods for Estimating Furniture Heat Release Rate
 - Furniture Calorimeter Testing
 - Mathematical Models Based on Bench-Scale Test Data
- Research Plan
 - Parametric Study on Mockups ⇒ Evaluate and Refine Models
 - Validation Used Furniture
- Results
- Conclusions



Southwest Research Institute – Fire Technology Department



INTRODUCTION (1)

- Upholstered furniture is often involved in residential fires, either as the first item ignited or as part of the fuel load
- ⇒ Residential fire reconstruction very often requires reliable estimates of upholstered furniture burning rates
- This is true regardless of whether a CFD code, a zone model, or another type of analysis is used
- The goal of this project is to develop guidelines for arson investigators on how to best estimate the burning rate of upholstered furniture



Southwest Research Institute – Fire Technology Department



INTRODUCTION (2)

- Uncertainty of the burning rate estimates depends on the extent of testing that can be performed
- Under ideal circumstances identical items as those involved in the fire are available for laboratory testing
- This is usually not the case and it is more likely that enough specimens are available for small-scale testing
 - ASTM E 1354 Cone Calorimeter
 - ASTM D 7309 Microscale Combustion Calorimeter
- In the worst case no undamaged materials can be recovered from the fire scene ⇒ Database



Southwest Research Institute – Fire Technology Department



ESTIMATING HRR OF FURNITURE Furniture Calorimeter Testing (1)

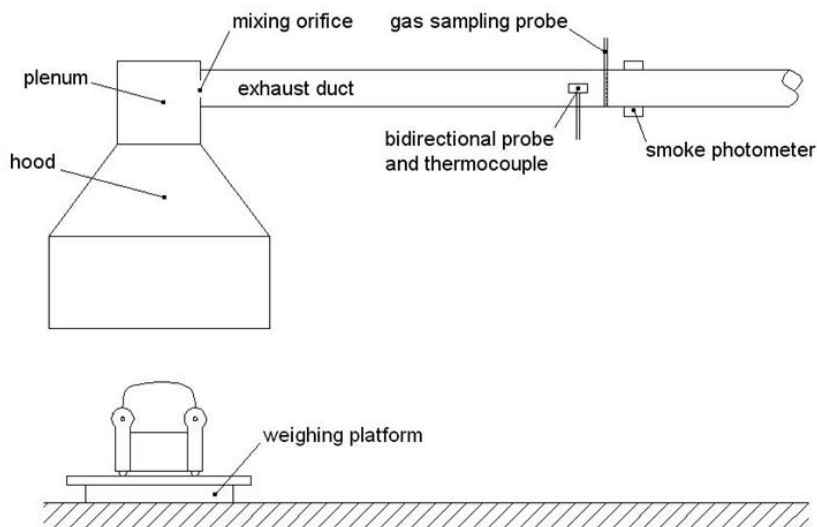

Southwest Research Institute – Fire Technology Department



ESTIMATING HRR OF FURNITURE Furniture Calorimeter Testing (2)



Southwest Research Institute – Fire Technology Department



ESTIMATING HRR OF FURNITURE Based on Cone Calorimeter Data (1)

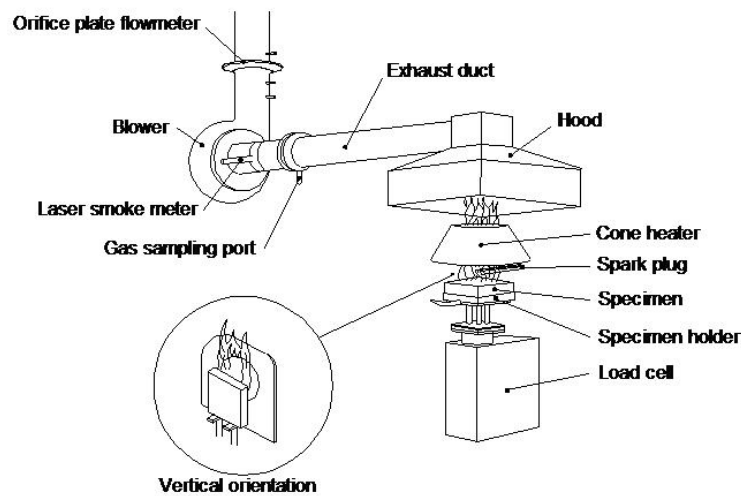

Southwest Research Institute – Fire Technology Department



ESTIMATING HRR OF FURNITURE Based on Cone Calorimeter Data (2)

- ASTM E 1354, NFPA 271 and ISO 5660 Parts 1 & 2
- 100 x 100 mm specimen size
- Maximum 50 mm thick ⇒ **Limitation**
- Irradiance can be set at 0 to 100 kW/m² ⇒ **Which Level(s)**
- Pyrolyzates ignited with electric spark
- Specimen placed on load cell (mass loss)
- Heat and smoke release measured in duct
- ASTM E 1474 for upholstered furniture components



Southwest Research Institute – Fire Technology Department



ESTIMATING HRR OF FURNITURE Based on Cone Calorimeter Data (3)

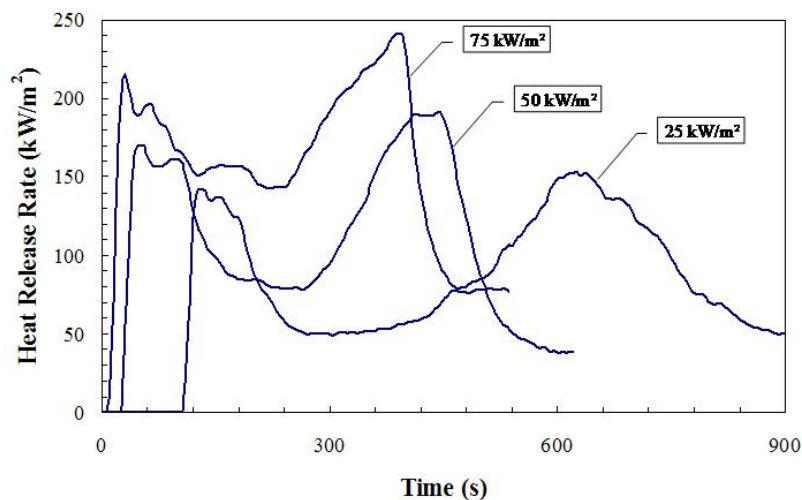

Southwest Research Institute – Fire Technology Department



ESTIMATING HRR OF FURNITURE ASTM E 1474 Specimen Preparation (1)

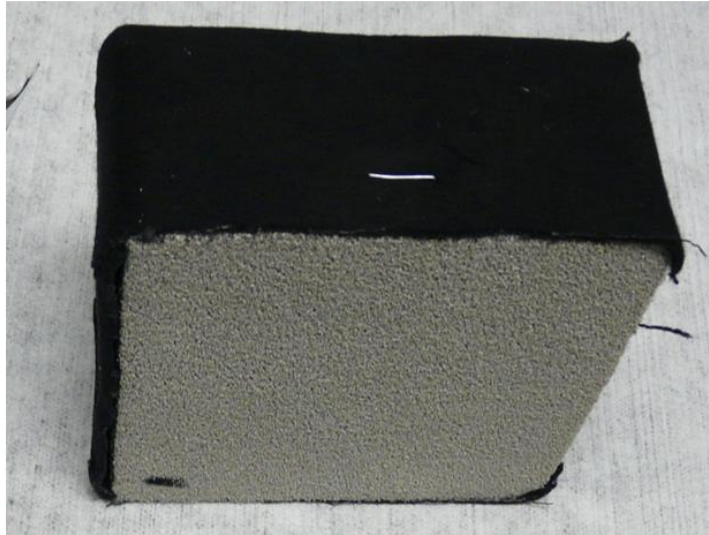

Southwest Research Institute – Fire Technology Department



ESTIMATING HRR OF FURNITURE ASTM E 1474 Specimen Preparation (2)



Southwest Research Institute – Fire Technology Department



ESTIMATING HRR OF FURNITURE CBUF I Model (1)

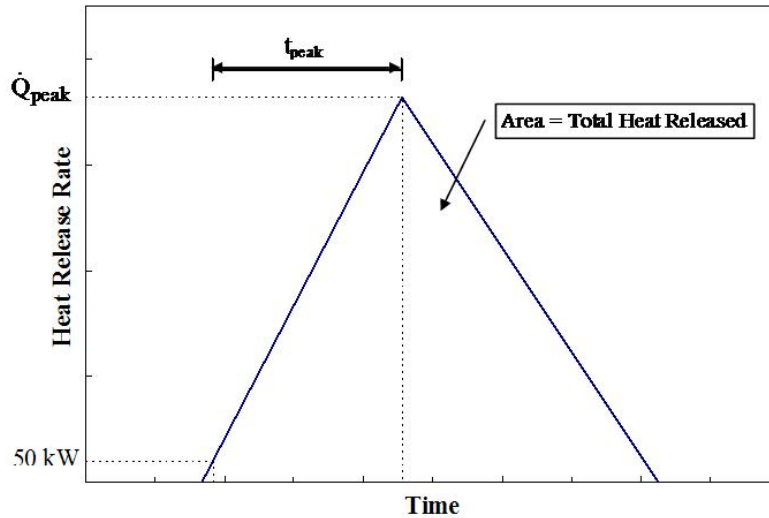

Southwest Research Institute – Fire Technology Department



ESTIMATING HRR OF FURNITURE CBUF I Model (2)

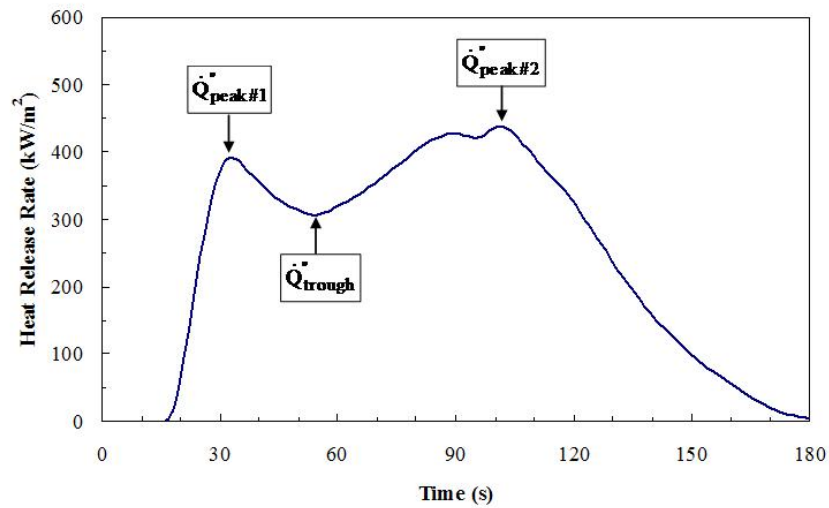

Southwest Research Institute – Fire Technology Department



ESTIMATING HRR OF FURNITURE Microscale Combustion Calorimeter (1)

- ASTM D7309 MCC was designed by the FAA
- Specimen size: 1-10 mg
- Correlates well with other flammability tests
- Useful in developing fire-resistant polymers
- Used at SwRI in support of product certification

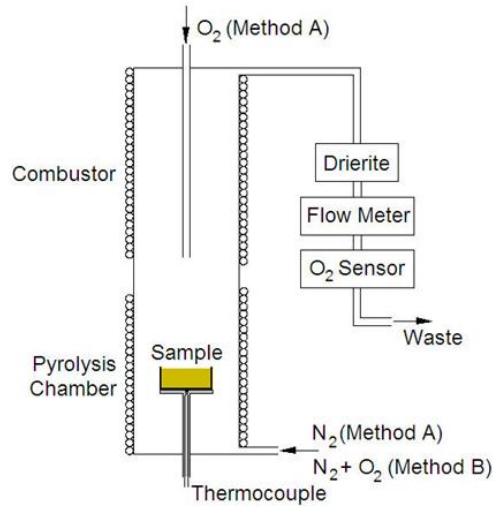

Southwest Research Institute – Fire Technology Department



ESTIMATING HRR OF FURNITURE Microscale Combustion Calorimeter (2)

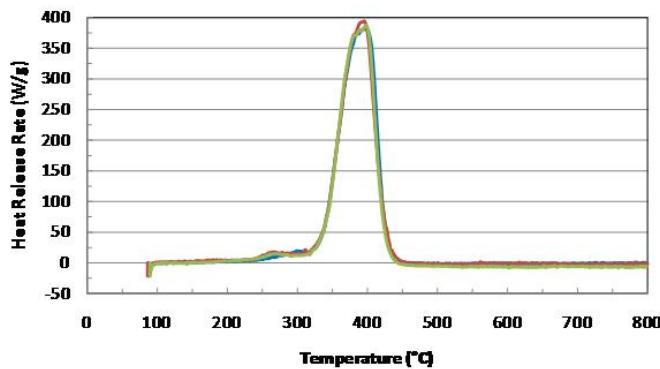

Southwest Research Institute – Fire Technology Department



ESTIMATING HRR OF FURNITURE Babrauskas' Model Predictions (1)

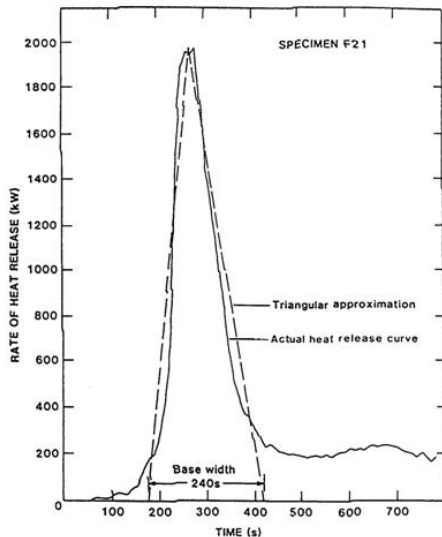

$$\dot{Q}_{\max} = 210[\text{FF}][\text{PF}][\text{CM}][\text{SF}][\text{FC}]$$

- [FF] = Fabric Factor
- [PF] = Padding Factor
- [CM] = Combustible Mass
- [SF] = Style Factor
- [FC] = Frame Combustibility

$$t_b = [\text{FM}][\text{CM}]\Delta h_c \dot{Q}_{\max}$$

- [FM] = Frame Material Factor
- Δh_c = Heat of Combustion (kJ/kg)



Southwest Research Institute – Fire Technology Department



RESEARCH PLAN Overview

- **Parametric Study of Upholstered Furniture Mockups**
 - Untreated vs. FR treated fabric (problems finding FR fabric)
 - 5 padding materials (low and high density polyurethane foam, CAL TB 117 foam, BS 5852 crib #5 foam, polyester fiber fill)
 - 3 ignition sources (CAL TB 133, BS 5852 source 1, pool fire)
 - 3 locations (seat, front bottom, back)
 - Chairs and 1-, 2- and 3-seat sofa mockups were tested
- Test mockup materials in Cone Calorimeter and MCC
- Fine-tune existing models based on mockup data
- Evaluate predictive capability of improved models for used furniture (obtained 24 sets from SwRI employees)



Southwest Research Institute – Fire Technology Department



RESEARCH PLAN

Example of Used Furniture Item



Southwest Research Institute – Fire Technology Department



RESULTS

Fractional Factorial Experiments (1)

- 3 padding materials (non-FR cotton fabric in all tests)
 - Low density polyurethane foam
 - High density polyurethane foam
 - CAL TB 117 polyurethane foam
- 3 ignition sources
 - Large propane burner (CAL TB 133 or ASTM sand box burner)
 - BS 5852 source 1 or 2
 - Pool fire (2 or 4 oz of gasoline)
- 3 locations: seat, front bottom, back
- Nine duplicate room tests on one-seat and three-seat sofas (thirty-six tests in total)



Southwest Research Institute – Fire Technology Department



RESULTS

Fractional Factorial Experiments (2)

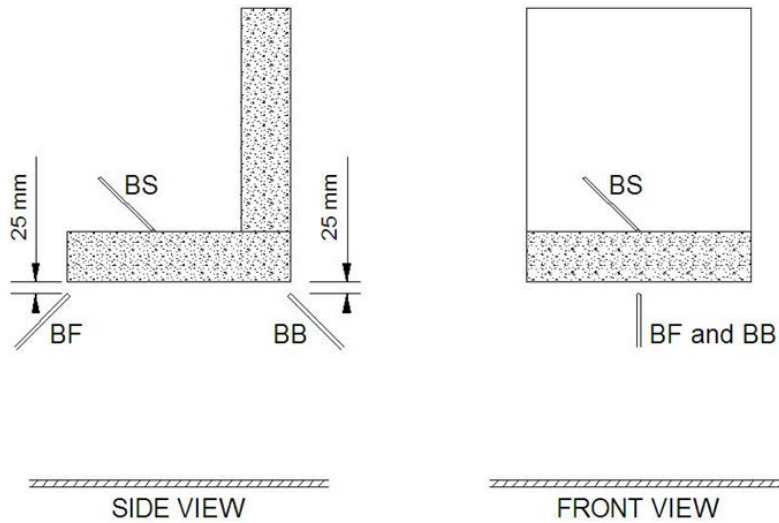

Southwest Research Institute – Fire Technology Department



RESULTS

Fractional Factorial Experiments (4)

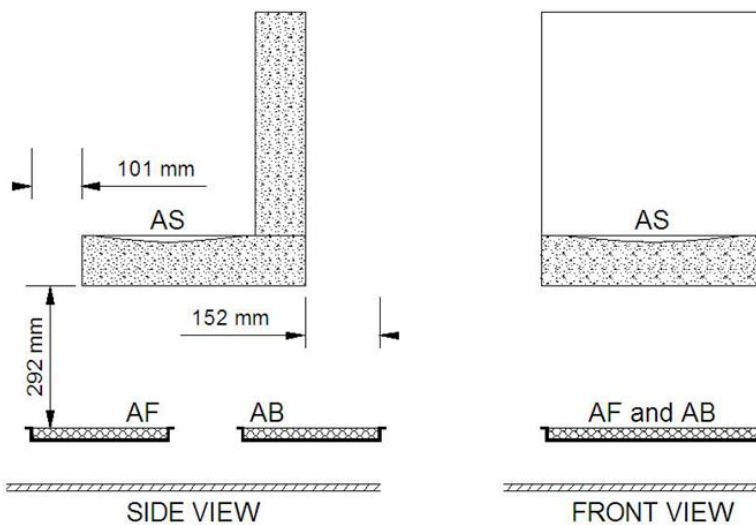

Southwest Research Institute – Fire Technology Department



RESULTS

Fractional Factorial Experiments (4)

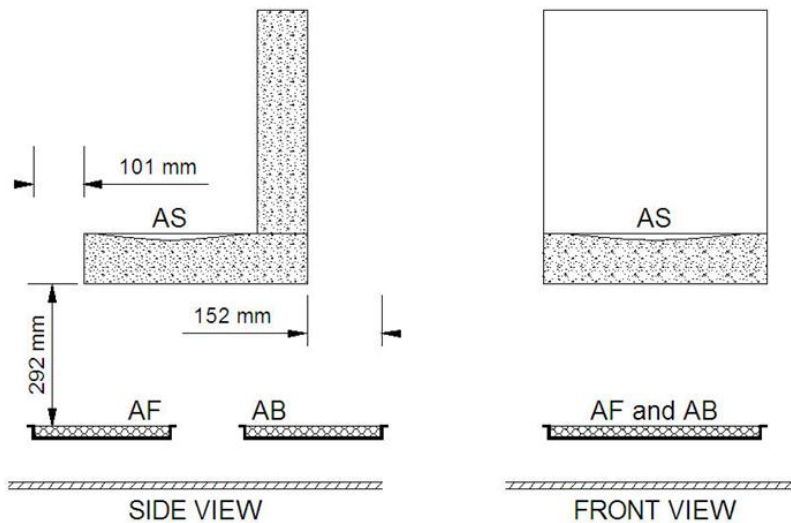

Southwest Research Institute – Fire Technology Department



RESULTS

Fractional Factorial Experiments (5)

- The HRR of a 3-seat sofa is very sensitive to the top surface location where the ignition source is applied
- The type of ignition source significantly affects the ignition delay t_0
 - No significant difference between large burner and pool fire
 - Small flame source results in a significant increase of t_0 .
- Peak HRR is strongly affected by the padding material (significantly lower for CAL TB 117 foam)
- Back ignition generally resulted in a shorter ignition delay, but a slower fire growth rate and lower peak HRR



Southwest Research Institute – Fire Technology Department



RESULTS

Babrauskas' Model for Mockups

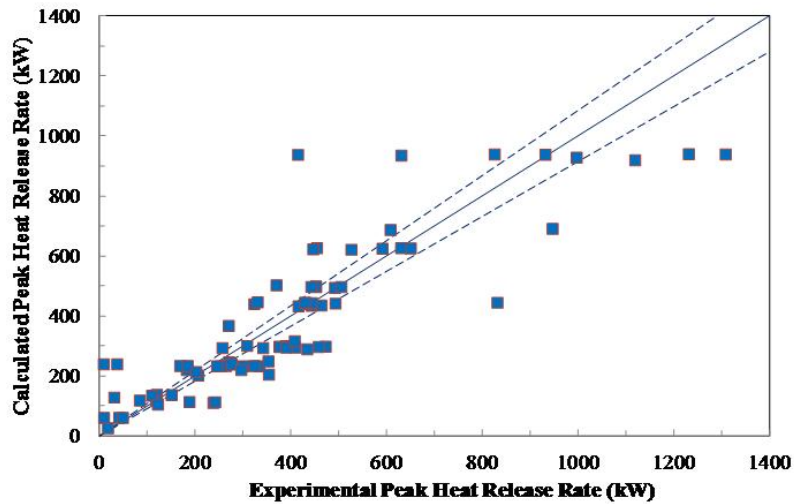

Southwest Research Institute – Fire Technology Department



RESULTS

Model Predictions for Test LRM123AF1

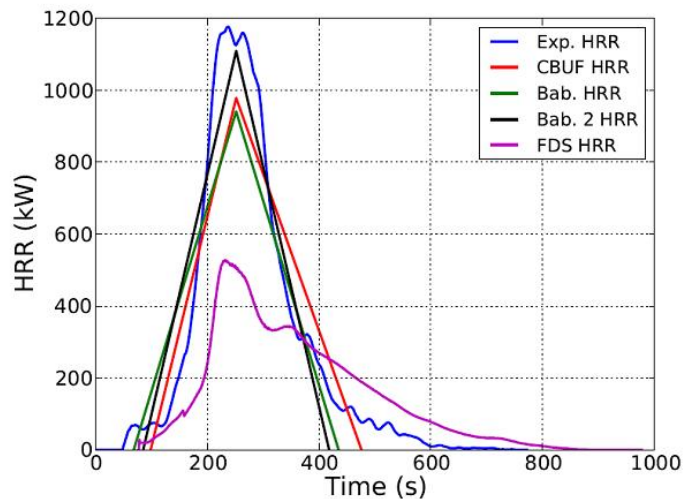

Southwest Research Institute – Fire Technology Department



RESULTS

CFAST Predictions for Test LRM123AF1

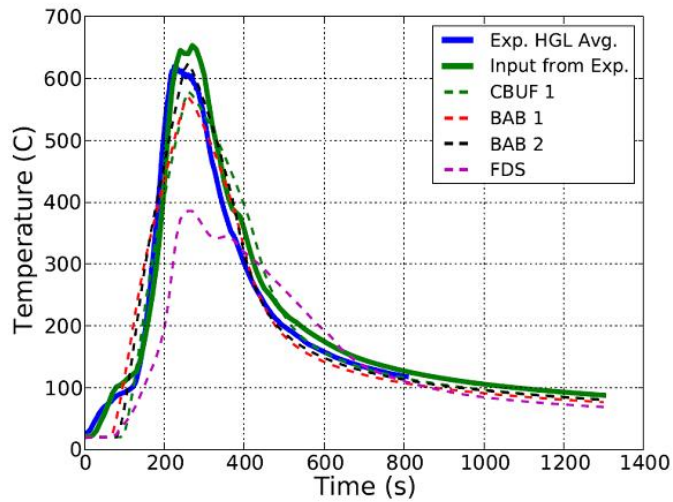

Southwest Research Institute – Fire Technology Department



RESULTS

Babrauskas' Model for Used Furniture

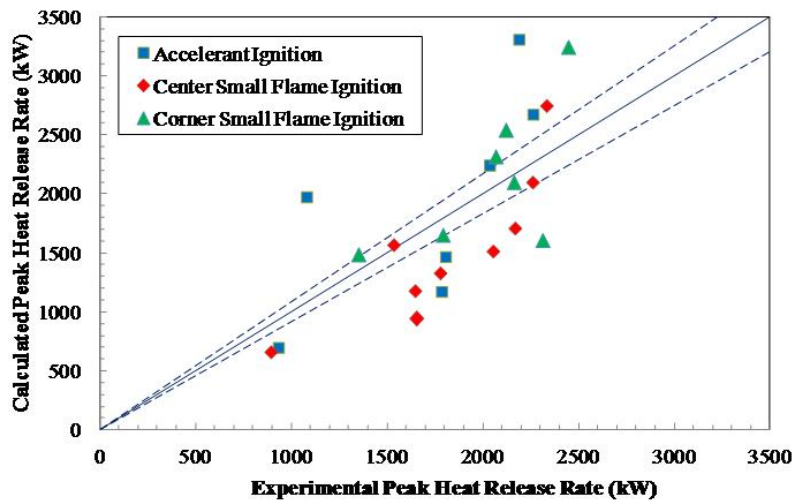

Southwest Research Institute – Fire Technology Department



SOME CONCLUSIONS (1)

- Even if identical item(s) are available for furniture calorimeter testing, the measured HRR is subject to aleatory and, more importantly, epistemic uncertainty
- The use of FR treated foam appears to significantly delay ignition and reduce HRR in accidental fires
- In fires where the furniture is exposed to a severe ignition source the effect on ignition delay is negligible
- The HRR from a single item was generally not sufficient to reach flashover in a 12x16x9' room with open door
- The used furniture generated large amounts of smoke



Southwest Research Institute – Fire Technology Department



SOME CONCLUSIONS (2)

	Mass (kg)	Peak HRR (kW)		Ignition Delay (s)
1-Seat	33.7 ± 11.3	1455 ± 401	Accelerant	71 ± 55
2-Seat	39.4 ± 6.1	1726 ± 113	Small Flame Center	435 ± 214
3-Seat	67.2 ± 17.5	2073 ± 356	Small Flame Corner	171 ± 52



Southwest Research Institute – Fire Technology Department



QUESTIONS?



<http://www.fire.swri.org>

APPENDIX D.5 Bradley Pabody, USFA

NFIRS Overview

The National Fire Incident Reporting System

An Overview

NFIRS

What is the National Fire Incident Reporting System?

- Voluntary - 23,000 Departments Participate from all 50 states
- Incident-based
- Locally driven – quality, completeness, content
- More than 1.2 million fires reported for 2010
- 22 million total incidents reported for 2010



Homeland
Security

NFIRS Participation

Fire Departments Reporting Per Year 1980-2010

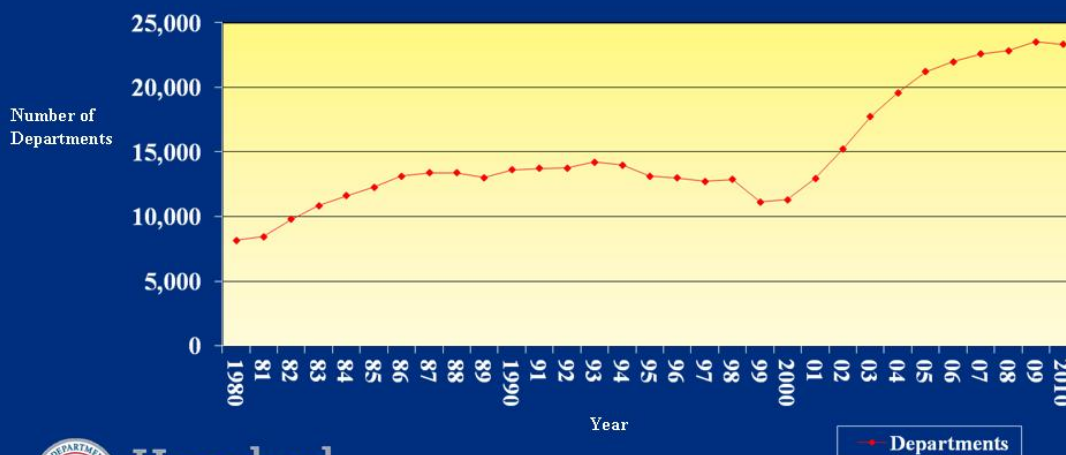

Homeland Security

Fire Incidents Reported Per Year 1980-2010

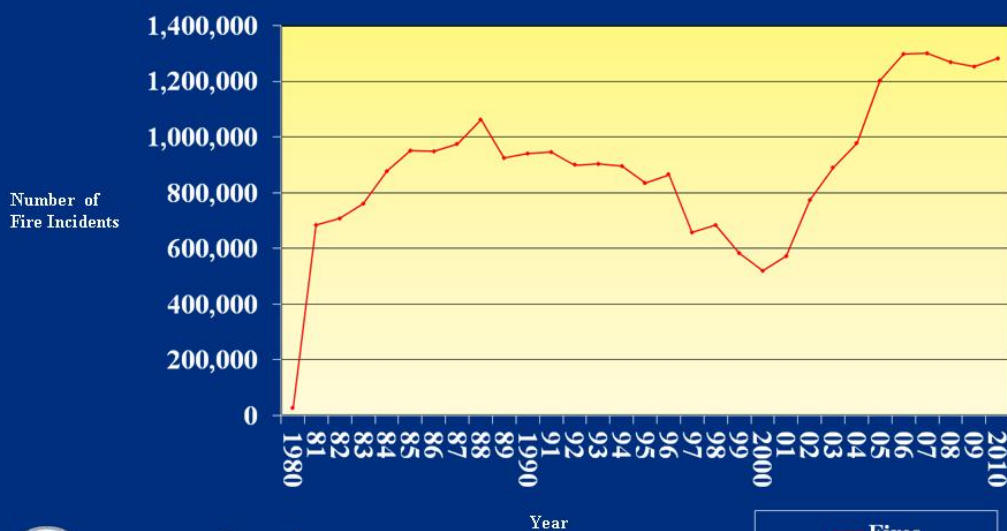

Homeland Security

NFIRS Background

- Initial National Fire Incident Reporting System was created in 1975
 - NFIRS Version 2.0, 1976
 - NFIRS Version 3.0, 1980
 - NFIRS Version 4.0, 1985
 - NFIRS Version 4.1, 1990
 - NFIRS Version 5.0, 1999



Homeland
Security

How do we collect fire data?

NFIRS data flow



Homeland
Security

6

The NFIRS Cycle: Fire Incident Data In / Information Out

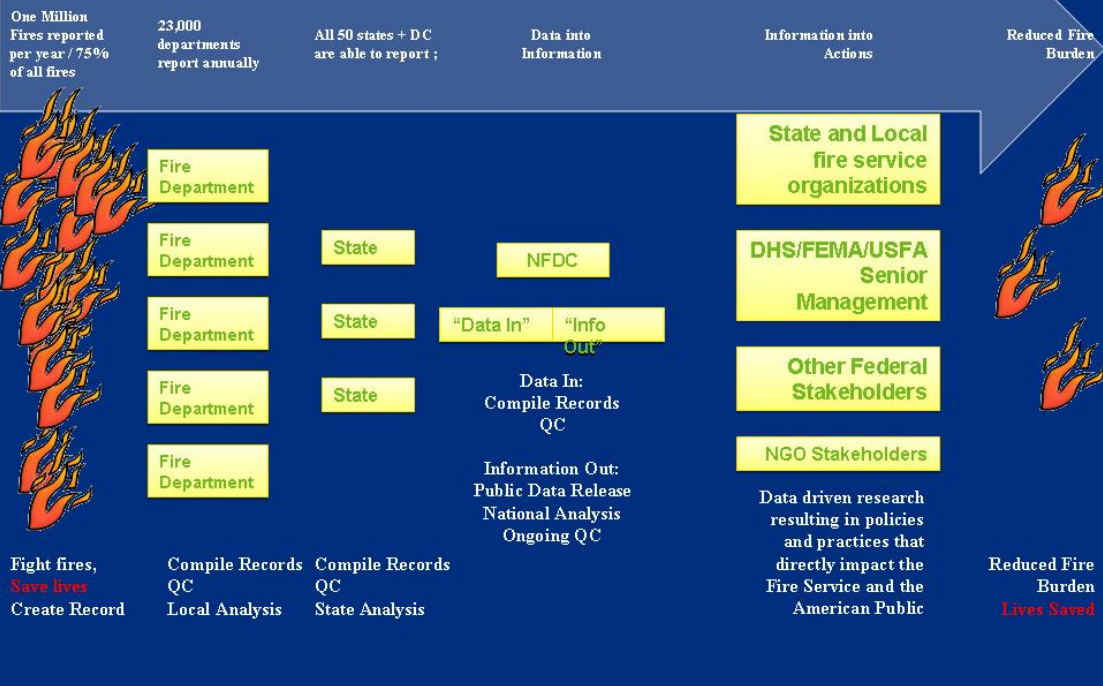

NFIRS Modules

- The **Basic Module** (NFIRS-1) captures general information on every incident (or emergency call) to which the department responds.
- The **Fire Module** (NFIRS-2) is used to describe each fire incident to which the department responds. For wildland fire incidents, the Wildland Module can be used instead of the Fire Module if that option is available by your state reporting authority.
- The **Structure Fire Module** (NFIRS-3) is used to describe each structure fire to which the department responds. This module is used in conjunction with the Fire Module.
- The **Civilian Fire Casualty Module** (NFIRS-4) is used to report injuries or deaths to civilians or other emergency personnel (e.g., police officers, non-fire department/EMS personnel) that are related to a fire incident. This module is used in conjunction with the Fire Module and, if applicable, the Structure Fire Module. Non-fire-related injuries or deaths to civilians can be reported on the EMS Module.



U.S. DEPARTMENT OF
Homeland
Security

NFIRS Modules

- The *Fire Service Casualty Module* (NFIRS-5) is used to report injuries and deaths of firefighters. The module can also be used to report the exposure of a firefighter to chemicals or biological agents at an incident where that exposure does not result in any symptoms at that time but that manifest themselves at a later date. This module may be used with any of the other modules
- The *EMS Module* (NFIRS-6) is completed by fire departments that provide emergency medical services. The module is used to report all medical incidents where the department provided the primary patient care. This includes incidents where there were civilian fire-related casualties and a Civilian Fire Casualty Module was completed and where there were firefighter fire-related casualties and a Fire Service Casualty Module was completed. (This module does not serve as a patient care record, but it can be used in conjunction with the local requirements for patient care.)



Homeland
Security

NFIRS Modules

- The *Hazardous Materials Module* (NFIRS-7) is completed to report spills or releases of 55 gallons or more of hazardous materials or when special HazMat actions were taken. As appropriate, the module is used in conjunction with the Fire Module or other modules to provide detailed information about incidents involving hazardous materials.
- The *Wildland Fire Module* (NFIRS-8) is completed to report incidents that involve wildland or vegetation fires. The module is used in lieu of the Fire Module for wildland fire incidents.
- The *Apparatus or Resources Module* (NFIRS-9), a department-use module, is completed to report data specific to each piece of apparatus that responds to an incident. It includes information that can be used to calculate response time and time out of service. This module is not used if the Personnel Module is used.



Homeland
Security

NFIRS Modules

- The *Personnel Module* (NFIRS-10), a department-use module, is completed to report the same information as on the Apparatus or Resources Module, but it also provides for tracking the personnel associated with that apparatus.
- The *Arson Module* (NFIRS-11) is completed to report additional information on fires that have been coded by the department as “intentionally set.”
- In addition to the 11 modules, a *Supplemental Form* (NFIRS-1S) can be used to report information on additional persons and entities involved in the incident and to collect additional special studies fields. This paper-only form extends the amount of information collected in the Basic Module.



Homeland
Security

NFIRS Data Analysis

- National fire data analyses are done by USFA to answer questions about the frequency, causes, spread, and extinguishment of fires and on the causes and nature of injuries.
- Information about the national fire problem is disseminated to the public via the USFA website and published reports and analyses.



Homeland
Security

Fire Statistics

The USFA website contains statistics on fires that occur in the United States and analytical and topical reports that describe the national fire problem. Also included are statistics related to firefighters and fire departments.

<http://www.usfa.dhs.gov/statistics>



Homeland
Security

NFIRS Enhancements

In order to facilitate a modular approach to the NFIRS enhancement process, the work has been separated into the following five discrete phases:

- **Data Entry Browser Interface.** This feature provides for a totally web based data entry tool eliminating the need to download and install client software on the user's computer. Use of approved 3rd party commercial software as an alternative will still be permitted. *(planned release date: Spring, 2010)*
- **Data Warehouse & Mining.** This feature will provide flexible and efficient ways of retrieving and exporting data. *(planned release date: Spring, 2011)*



Homeland
Security

- **New NFIRS Web Portal.** This objective continues the modernization of the USFA solution by adding a web based portal, and implements a role based security model to give users single point access for the NFIRS data entry, report dashboards and access to administrative applications. While the individual applications would maintain a similar look and feel they will be encapsulated into a single location within the portal.
- **Revision of the NFIRS Data Entry Applications.** This objective provides a true integration of the portal with the Incident Reporting application as the core with the addition of a new rules engine.
- **Enhanced User Interface.** The final objective adds the remaining functionality to complete the NFIRS application. GIS will be incorporated into the Incident Reporting application as well as administrative applications to support system users.



**Homeland
Security**

NFIRS Enhancements

Once complete, changes to the system will result in the following:

- Improved user experience through improvements to the user interface.
- Improved system performance.
- Overhaul of the USFA NFIRS 5.0 system software, applications and infrastructure.
- Addition of new or enhanced capabilities to USFA NFIRS 5.0 software.
- Brings NFIRS system software in line with Department of Homeland Security (DHS) and Federal Emergency Management Agency (FEMA) enterprise standards.



**Homeland
Security**

Contact Information

Brad Pabody
United States Fire Administration
National Fire Data Center
16825 South Seton Ave.
Emmitsburg, MD 21727

(301) 447-1340

brad.pabody@dhs.gov



Homeland
Security

APPENDIX D.6 John Hall, NFPA

How NFPA Measures Fire Problems and Safety Strategies with
Special Attention to Upholstered Furniture



How NFPA Measures Fire Problems and Safety Strategies

With Special Attention to Upholstered Furniture

John Hall
National Fire Protection Association

NIST Workshop on Contribution of Upholstered
Furniture to Fire Losses

March 2012



Overview

- Always start with NFIRS national estimates
- Data elements related to prevention
- Data elements related to fire growth
- Options when NFIRS isn't enough



NFIRS National Estimates

- NFIRS provides details
 - Voluntary at federal level
 - Not a statistical sample
- NFPA's fire department survey is a statistical sample of summary data
- NFIRS percentages are used with NFPA projections
- See 1989 *Fire Technology* article by Hall and Harwood for rules



How Fires Get Counted

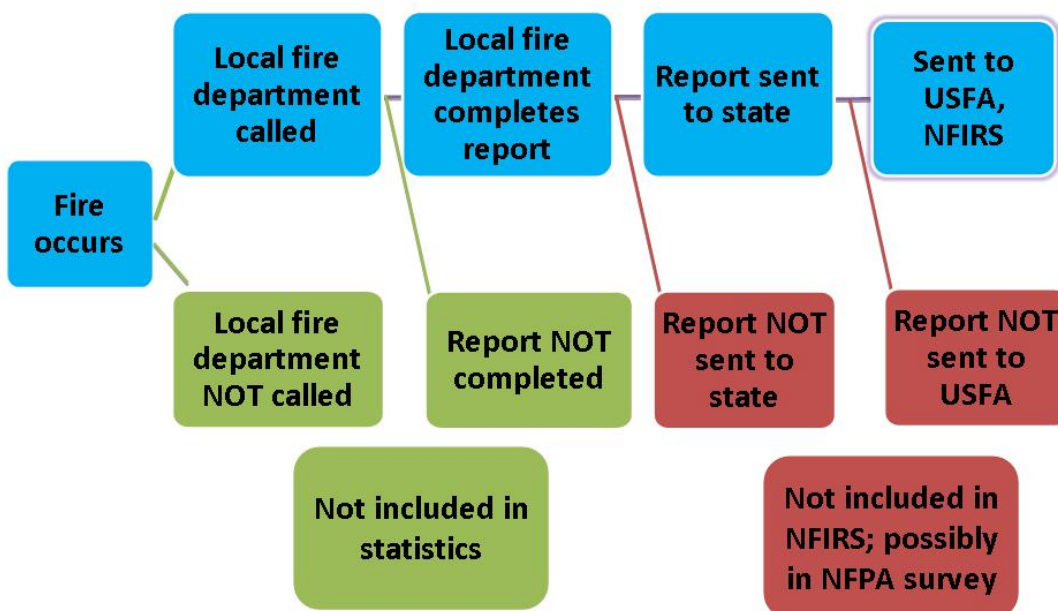



NFIRS National Estimates Analysis Choices

- What level of detail in incident type and property use to use in doing calculations
 - Residential structure vs. home structure
- How to treat confined structure fires
- Separate treatment of very large incidents
- Using death certificates or insured loss estimates rather than NFPA survey as a basis for scaling up NFIRS



Data Elements Related to Prevention

- Six data elements with details of ignition
- “Cause” – primarily to identify intentional
- Area of origin – which room or space
- Heat source and equipment involved in ignition
 - What provided the heat for ignition?
- Item first ignited and Type of material first ignited
 - What provided the first fuel?
- Upholstered furniture is item first ignited 21



Prevention Data Elements Analysis Choices

- How do you handle unknowns?
 - NFPA proportionally allocates unknowns for any data element but takes account of skip patterns
- Which fires do you consider to be unknowns?
 - For item first ignited, unknowns are UU or blank; 00 is considered unclassified
- Are certain fires considered outside scope (e.g., CPSC's non-addressable fires)?
 - NFPA does not exclude intentional fires and fires started by playing with heat source; those issues are addressed when you estimate the leverage of a particular strategy



Data Elements Related to Prevention

- Home fire problem starting with ignition of upholstered furniture, 2006-2010 average
- 6,700 reported structure fires per year
 - 2% of total
- 480 associated civilian deaths per year
 - 19% of total; largest share for any item first ignited
- 840 associated civilian injuries per year
 - 7% of total
- \$427 million per year in direct property loss
 - 6% of total



Data Elements Related to Prevention

- **What material is being ignited?**
- Fabric made of cotton, blend, rayon or wool
 - 72% of fires, 76% of deaths; 2005-2009 averages
- Unclassified fabric, textile or fur
 - 14% of fires, 15% of deaths
- Plastic
 - 2% of fires, 0% of deaths
- Unclassified type of material
 - 2% of fires, 2% of deaths
- Plastic-coated fabric
 - 1% of fires, 0% of deaths



Data Elements Related to Prevention

- **How is the upholstered furniture ignited?**
- Smoking material (lighted tobacco product)
 - 28% of fires, 58% of deaths
- Candle
 - 10% of fires, 6% of deaths
- Hot ember or ash
 - 10% of fires, 7% of deaths
- Unclassified hot or smoldering object
 - 9% of fires, 4% of deaths
- Arcing
 - 8% of fires, 7% of deaths



Data Elements Related to Prevention

- **How is the upholstered furniture ignited?** (continued)
- Heat from operating equipment
 - 8% of fires, 5% of deaths
- Lighter
 - 8% of fires, 5% of deaths
- Unclassified heat from powered equipment
 - 5% of fires, 2% of deaths
- Unclassified heat source
 - 4% of fires, 2% of deaths
- Match
 - 3% of fires, 1% of deaths



Data Elements Related to Prevention

- **How is the upholstered furniture ignited?** (continued)
- Intentional ignitions are 13% of fires, 6% of deaths
- Playing fires are 8% of fires, 5% of deaths
- When fires start with equipment as heat source, largest shares of total fires are:
 - Heating equipment (9% of fires, 7% of deaths)
 - Electrical distribution or lighting equipment (9% of fires, 11% of deaths)



Data Elements Related to Fire Growth

- **How large is the final extent of flame?**
- Confined to object of origin – 24% of fires, 6% of deaths
- Confined to room of origin but not confined to object of origin – 34% of fires, 25% of deaths
- Beyond room of origin (our best indicator of a fire that reached flashover) – 42% of fires, 69% of deaths



Data Elements Related to Fire Growth

- **How often is upholstered furniture the principal contributor to fire growth?**
- In NFIRS version 5.0 (1999 to present), the relevant data element is Item Contributing Most to **Flame Spread**
- Firefighters can skip this data element if
 - No significant flame spread
 - No flame spread beyond item first ignited
 - Cannot determine flame spread
- Check box is used if this item is the same as the Item First Ignited



Data Elements Related to Fire Growth

- **How often is upholstered furniture the principal contributor to fire growth?**
- In early NFIRS (1980 to 1983), the most relevant data element was Most Significant Factor Contributing to **Flame Travel**
- Some choices are burnable items.
- Other choices are failed or defeated barriers or avenues of fire spread without barriers
- Other data elements (not all used in NFIRS) were for item or type of material generating most significant flame or smoke



Data Elements Related to Fire Growth

- **Flame spread and flame travel are not the same as fire growth**
- The names of the data elements suggest an interest in flame spread along a surface or through a space
- As opposed to fire growth due to involvement of a larger fraction of the volume or mass of a major fuel item
- These data elements may not provide a strong estimate of fires where upholstered furniture contributes as the primary secondary item ignited, but we have nothing better.



Data Elements Related to Fire Growth

- **Items most often first ignited when flame is not confined to room of origin and upholstered furniture is the item contributing most to flame spread**
- **Upholstered furniture**
 - 60% of fires, 72% of deaths
- **Unclassified furniture or utensil**
 - 6% of fires, 1% of deaths
- **Mattress or bedding**
 - 4% of fires, 3% of deaths
- **Wire or cable insulation**
 - 4% of fires, 5% of deaths
- **Floor covering**
 - 3% of fires, 4% of deaths



Data Elements Related to Fire Growth

- **Items most often first ignited when flame is not confined to room of origin and upholstered furniture is the item contributing most to flame spread (continued)**
- **Unclassified item**
 - 2% of fires, 0% of deaths
- **Papers**
 - 2% of fires, 4% of deaths
- **Multiple items**
 - 2% of fires, 1% of deaths
- **Interior wall covering**
 - 2% of fires, 1% of deaths
- **Clothing**
 - 2% of fires, 2% of deaths



Data Elements Related to Fire Growth

- **Items most often first ignited when flame IS confined to room of origin and upholstered furniture is the item contributing most to flame spread**
- **Upholstered furniture**
 - 68% of fires, 77% of deaths OR
 - 58% of fires, 66% of deaths if unknowns are cases of no flame spread
- **Unclassified furniture or utensil**
 - 6% of fires, 1% of deaths OR 5% of fires, 1% of deaths
- **Wire or cable insulation**
 - 4% of fires, 0% of deaths OR 4% of fires, 0% of deaths
- **Mattress or bedding**
 - 3% of fires, 2% of deaths OR 3% of fires, 2% of deaths
- **Floor covering**
 - 2% of fires, 1% of deaths OR 2% of fires, 1% of deaths



Options When NFIRS Isn't Enough

- **What can't you get from NFIRS alone?**
- Details of the type and composition of upholstered furniture
- Location of point of ignition on the furniture
- High-credibility estimates of fires where upholstered furniture is the primary fuel package involved but not the first fuel package
- Detailed scenarios that show when upholstered furniture is ignited and how important it is to the course of the fire



Options When NFIRS Isn't Enough

- **What are your options?**
- Try to add detail to NFIRS. **STOP!** The data collectors will not accept such a large additional data burden – and they probably lack the resources to routinely provide such detail anyway.
- Use a completely different database that has the needed detail. **STOP!** Any such database – e.g., documented investigations or incidents involved in court cases – is almost guaranteed to be statistically unrepresentative.



Options When NFIRS Isn't Enough

- **What are your options?**
- Use the NFIRS special study option. **MAYBE**
- If you work through local fire departments, be sure you don't ask for details they cannot reasonably be expected to collect.
- Probably better to conduct a special study through CPSC. They have done this before.
- Consider collecting samples from the involved upholstered furniture, so you can get details without overburdening field data collectors.



Options When NFIRS Isn't Enough

- **What are your options?**
- Build a probabilistic model. **YES!**
- For example, estimate percentage (p_i) of upholstered furniture in the national inventory having certain specified characteristics
- Using lab data, estimate relative ease of ignition (q_i) for upholstered furniture with different characteristics
- Then $p_i q_i / \sum p_j q_j$
is a derived estimate of the percentage of upholstered furniture fires having characteristics designated i



Options When NFIRS Isn't Enough

- **What are your options?**
- Build a probabilistic model. **Example #2**
- Estimate the number of home structure fires and deaths per year that extend beyond the room of origin AND do not start with ignition of upholstered furniture. Do the same for fires confined to room of origin but beyond object.
- Maybe also limit to areas of origin where upholstered furniture is commonly found OR eliminate areas of origin where upholstered furniture is not found (e.g., concealed wall space).



Options When NFIRS Isn't Enough

- **Modeling option** **Example #2 (continued)**
- Estimate the percentage of fires with those specs where upholstered furniture was the Item Contributing Most to Flame Spread
- Break down the estimates to distinguish different items first ignited
- And maybe different igniting heat sources.



Options When NFIRS Isn't Enough

- **Modeling option** **Example #2 (continued)**
- Obtain a sample of relevant fires with narratives. Or use your special study of upholstered furniture fires with more details.
- For each first item ignited, use narratives to fill in estimated details on what the first item typically was and where it was located.
- Now you can construct and weight scenarios for size and characteristics of the fire problem involving upholstered furniture as main fuel package but not first fuel package.



Options When NFIRS Isn't Enough

- **Modeling option** **Example #2 (continued)**
- Think you're done now? What about...
- The alternative avenues of fire growth that may become primary if upholstered furniture fire performance has been improved.
- You will need some lab work, possibly some physical modeling, to describe consequences for your scenarios with modified furniture
- And that includes modeling whether deaths still occur, as they will if occupant locations and fire conditions are not changed enough.



Options When NFIRS Isn't Enough

- **Starter list for alternative avenues: Items contributing most to flame spread when flame is not confined to room of origin and upholstered furniture is item first ignited**
- **Upholstered furniture**
 - 70% of fires, 71% of deaths
- **Unclassified furniture or utensil**
 - 6% of fires, 6% of deaths
- **Structural member or framing**
 - 5% of fires, 3% of deaths
- **Interior wall covering**
 - 4% of fires, 6% of deaths
- **Unclassified structural component or finish**
 - 3% of fires, 3% of deaths



Implications for the Workshop Topics

- For fires with flame beyond room of origin, upholstered furniture as secondary fuel package appears to add 69% to number of such fires with upholstered furniture as item first ignited
- And to add 39% to number of fire deaths
- Unless you think unclassified furniture is mostly upholstered furniture, in which case the mark-up drops to 52% for fires and 36% for deaths
- For fires with flame confined to room but beyond object of origin, secondary ignitions add 48% to fires and 31% to deaths, if unknowns are no-spread fires, not including unclassified furniture



Implications for the Workshop Topics

- All this is relative to *total* item first ignited upholstered furniture fires.
- If you exclude smoldering ignitions, the add-on percentages are much greater
- If you also exclude what CPSC calls non-addressable fires, the add-on percentages are much, much greater
- But remember that these secondary ignitions are no longer small open flame ignitions. Mitigation rather than prevention would presumably be the strategy of choice.



Implications for the Workshop Topics

- In less statistical terms...
- Secondary ignitions add significantly to item first ignited upholstered furniture fires
- Just how significantly is subject to a fair degree of variation in estimates
- Which might be reduced through additional analysis and some probabilistic modeling



Implications for the Workshop Topics

- Estimating how much those fires and losses might be reduced by better upholstered furniture flaming fire performance would likely involve:
 - Probabilistic modeling
 - Physical modeling
 - New lab data
 - Stats from existing fire data
 - Stats from special studies
 - Basically, everything we have and can get



For More Information

- Contact info

John Hall

NFPA

1 Batterymarch Park

Quincy, MA 02169-7471

(617) 984-7460

jhall@nfpa.org

APPENDIX D.7 David Butry, NIST

The Use of NFIRS in Economic Analysis

The Use of NFIRS in Economic Analysis

Workshop on Quantifying the Contribution of
Flaming Residential Upholstered Furniture to
Fire Losses in the United States

March 23-23 2012

David T. Butry
Applied Economics Office
Engineering Laboratory
NIST

Fundamental Economic Challenge

- Minimize the sum of fire-related costs plus losses (or net value change)
 - Costs are inputs to prevent or mitigated fire losses
 - E.g., Investments spent on fire service, fire protection in constructed facilities, smoke alarms
 - Losses are incurred because of (unwanted) fires
 - E.g., Economic value of property damage, fatalities, business interruptions

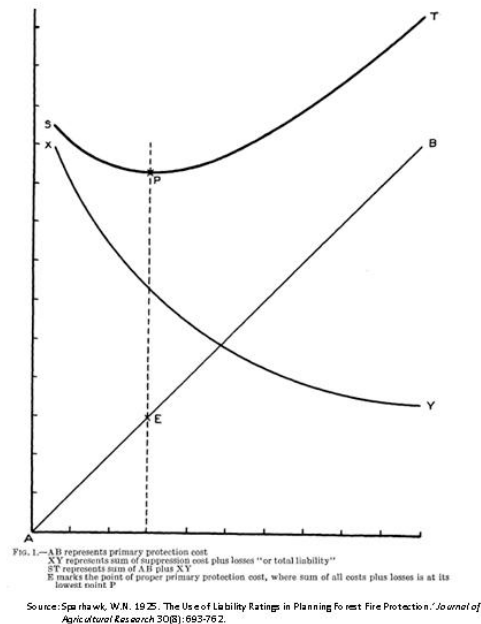

Min (C+L)

- In the economic problem, levels of investments into fire protection and mitigation are chosen ('solved') to obtain the minimum
 - Greater spending on costs results in lower losses
 - Of course, it requires an understanding of how costs affect losses
- A tradeoff occurs from substituting costs for losses
 - At the minimum (optimum), an additional \$1 invested into fire protection and mitigation results in an additional reduction of loss of $< \$1$
 - Beyond the minimum, 'the cure is worse than the disease' (economically)
- Under-investments can (does) occur
 - When the benefits of fire protection and mitigation are not fully realized
 - E.g., When all the benefits aren't (can't be) measured
 - When benefits are not internalized
 - When those who make the investment are not the (full) beneficiary

Common Economic Themes

- Risk Analysis
- Uncertainty & Risk Preferences
- Benefit-Cost Analysis
- Cost-Effectiveness
- Return on Investment
- Loss Estimation



⇒ All require some understanding of the fire problem (*needed are data on costs and losses*)

Where Does NFIRS Fit In?

- Made up of various modules describing the fire incident
 - Basic
 - Fire
 - Structure
 - Civilian fire casualty
 - Fire service casualty
 - EMS
 - Hazardous materials
 - Wildland fire
 - Apparatus or resources
 - Personnel
 - Arson

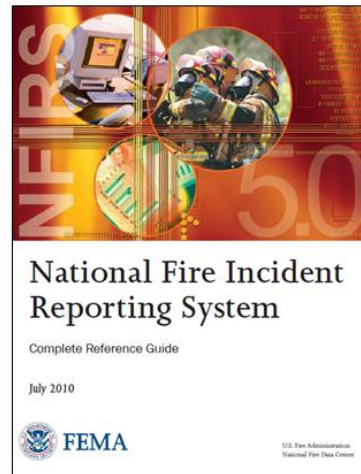

Ignition Specifics

Table 4.6: NFIRS Categories by Causal Detail for Fire Prevention Purposes

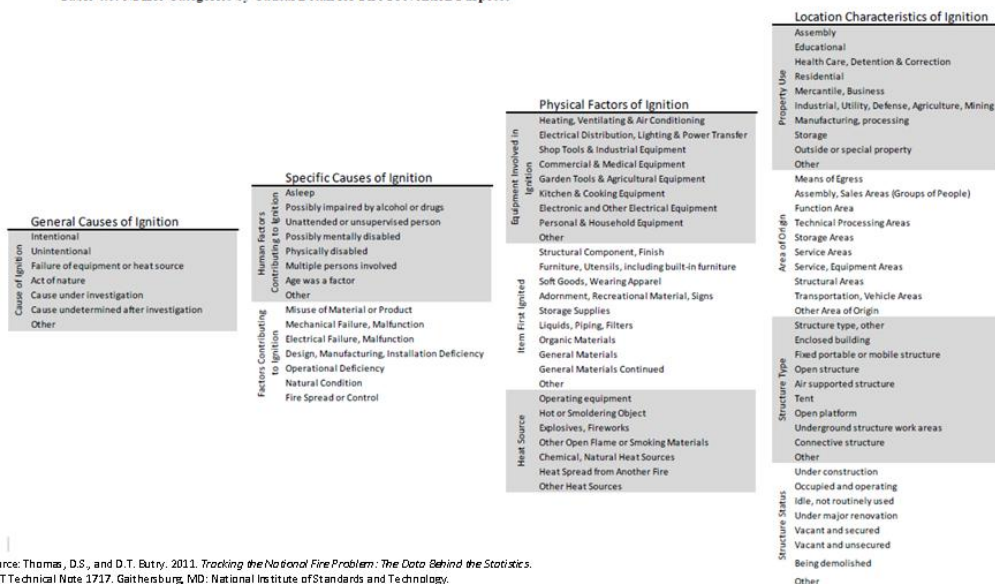

Source: Thomas, D.S., and D.T. Butry. 2011. *Tracking the National Fire Problem: The Data Behind the Statistics*. NIST Technical Note 1717. Gaithersburg, MD: National Institute of Standards and Technology.

Some Uses of NFIRS Data

- Measure components of fire risk (probability x consequence)
 - Likelihood of occurrence
 - Fatalities, injuries, and property damage
- Understand factors related to ignition
 - E.g., Item first ignited
- Understand factors related to losses
 - E.g., Presence of a smoke alarm
- *However, NFIRS doesn't provide (as) much related to fire protection and mitigation costs.*

Using NFIRS Data for Economic Analysis

(A Quick NIST Example)

- Objective: to measure the performance of residential fire sprinklers in one- and two-family homes
 - Focus on fatalities averted
 - Convert estimated physical performance into 'cost of life saved'
- Challenge: to measure performance *while* controlling for 'confounders'
 - Smoke alarm technology
 - Distance to fire department
 - Structure age
 - Family income
 - Family age
 - ...
- NFIRS fire incidence data was used to control for differences between sprinklered and non-sprinklered fire incidents
- Basic finding: sprinklers reduce fire-related fatalities even when controlling for the benefits provided by smoke alarm technologies and differences in housing and family characteristics

Source: Butry, D.T. (Forthcoming.) 'Comparing the Performance of Residential Fire Sprinklers with Other Life Safety Technologies.' *Accident Analysis and Prevention*.

RUF & NFIRS

- Where is upholstered furniture tracked in NFIRS?
 - Fire Module: *Item First Ignited* (code 21)
 - Structure Module: *Item Contributing Most to Flame Spread* (code 21)
 - Used when item first ignited was *not* the item contributing most to flame spread.
- How well is it tracked?
 - *Item First Ignited* is a required field
 - *IFI* is reported 91% of time for non-confined residential fire incidents (2002-2009)
 - RUF *IFI* fires accounted for 2% of all fires
 - *Item Contributing Most to Flame Spread* is not a required field
 - Accounted for 28% of all non-confined residential fire incidents (2002-2009)
 - RUF *ICMFS* fires accounted for 1% of all fires

NFIRS RUF Incidents by Year

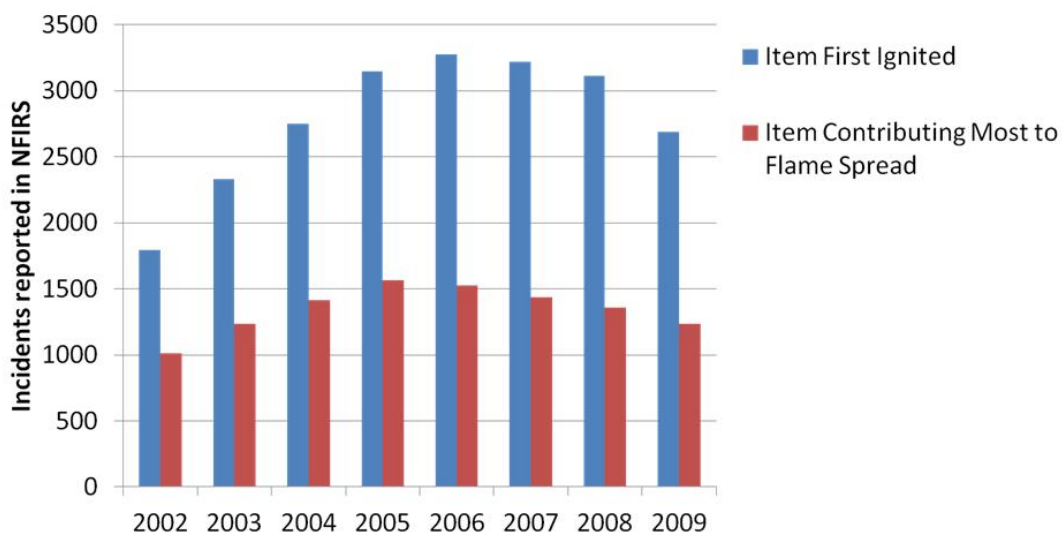

RUF Flame Spread Comparison

	None (Object)	Room	Beyond Room
RUF Fires			
Item First Ignited	27.2% (6,074)	32.6% (7,286)	40.2% (8,964)
Item Contributing Most to Flame Spread	4.0% (430)	42.6% (4,592)	53.4% (5,759)
All Residential Fires			
Item First Ignited	30.6% (296,078)	28.9% (279,509)	40.4% (390,849)
Item Contributing Most to Flame Spread	6.1% (18,175)	38.6% (115,613)	55.3% (165,616)

Notes: (1) Item Contributing Most to Flame Spread is NOT Item First Ignited
 (2) From 2002-2009 there were 1,064,600 NFIRS-reported non-confined residential structure fires

RUF National Estimates

(Quick and Dirty)

	2002	2003	2004	2005	2006	2007	2008	2009	Total
Fires	7,888	6,475	6,454	6,119	6,266	5,773	5,278	4,380	48,632
Fatalities	361	372	397	345	297	334	285	220	2,610
Injuries	985	957	879	985	854	755	850	776	7,041
Property Damage (\$ million)	246	245	237	283	477	237	274	230	2,228

Notes: (1) Combined upholstered furniture fires as reported by *Item First Ignited* (21) and *Item Contributing Most to Flame Spread* (21)
 (2) Fatalities and injuries are for civilian only
 (3) Property damage includes property and content loss

Data Questions

- Do *Item First Ignited* and *Item Contributing Most to Flame Spread* account for all (most) of the fires involving RUF?
 - Do other ways exist to identify fires involving RUF?
- Is it difficult to determine if RUF was involved?
 - Is under-reporting likely?
- Are fires that spread beyond the room of origin 'special' or 'different' than those that don't?
 - Are there factors that affect both flame spread and the likelihood RUF is involved?
 - Are 'bad' fires more likely to contain a *Item Contributing Most to Flame Spread*?

Potential Economic Analyses

- Report national RUF fire estimates (numbers, fatalities, injuries, and property damage)
 - Pros: straightforward
 - Cons: ignores potential confounding effects from other factors
- Estimate RUF 'treatment' effect using statistical methods
 - Pros: Can 'deal with' confounding effects,
Provides 'causal' effect,
Creates a better understanding of RUF risks
 - Cons: Requires a greater understanding of fire behavior and the role of RUF and correlated factors,
Need to identify a baseline (counterfactual—RUF fire compared to what?),
Won't (directly) provide 'national estimates'

APPENDIX E—NFIRS Coding Forms

A FDID Star State Star Incident Date Star MM DD YYYY Station Incident Number Star Exposure Star

Delete Change No Activity

NFIRS-1 Basic

B Location Type Star Check this box to indicate that the address for this incident is provided on the Wildland Fire Module in Section B, "Alternative Location Specification." Use only for wildland fires. Census Tract _____

Street address
 Intersection
 In front of
 Rear of
 Adjacent to
 Directions
 U.S. National Grid

Number/Milepost Prefix Street or Highway Street Type Suffix
 Apt./Suite/Room City State ZIP Code

Cross Street, Directions or National Grid, as applicable

C Incident Type Star
 Incident Type _____

E1 Dates and Times Midnight is 0000
 Check boxes if dates are the same as Alarm Date.

Month Day Year Hour Min
 Alarm Star Arrival Star Controlled Last Unit Cleared Star

ARRIVAL required, unless canceled or did not arrive
 CONTROLLED optional, except for wildland fires
 LAST UNIT CLEARED, required except for wildland fires

E2 Shifts and Alarms Local Option
 Shift or Platoon Alarms District

E3 Special Studies Local Option
 Special Study ID# Special Study Value

D Aid Given or Received Star None

1 Mutual aid received
 2 Auto. aid received
 3 Mutual aid given
 4 Auto. aid given
 5 Other aid given

Their FDID Their State
 Their Incident Number

F Actions Taken Star

Primary Action Taken (1)
 Additional Action Taken (2)
 Additional Action Taken (3)

G1 Resources Star
 Check this box and skip this block if an Apparatus or Personnel Module is used.

Apparatus Personnel
 Suppression
 EMS
 Other

Check box if resource counts include aid received resources.

G2 Estimated Dollar Losses and Values

LOSSES: Required for all fires if known. Optional for non-fires. None

Property \$ _____
 Contents \$ _____

PRE-INCIDENT VALUE: Optional
 Property \$ _____
 Contents \$ _____

Completed Modules

Fire-2
 Structure Fire-3
 Civilian Fire Cas.-4
 Fire Service Cas.-5
 EMS-6
 HazMat-7
 Wildland Fire-8
 Apparatus-9
 Personnel-10
 Arson-11

H1 Casualties None
 Deaths Injuries
 Fire Service _____
 Civilian _____

H2 Detector Required for confined fires.
 1 Detector alerted occupants
 2 Detector did not alert them
 U Unknown

H3 Hazardous Materials Release None

1 Natural gas: slow leak, no evacuation or HazMat actions
 2 Propane gas: <21-lb tank (as in home BBQ grill)
 3 Gasoline: vehicle fuel tank or portable container
 4 Kerosene: fuel burning equipment or portable storage
 5 Diesel fuel/fuel oil: vehicle fuel tank or portable storage
 6 Household solvents: home/office spill, cleanup only
 7 Motor oil: from engine or portable container
 8 Paint: from paint cans totaling <55 gallons
 0 Other: special HazMat actions required or spill > 55 gal (Please complete the HazMat form.)

Mixed Use Property Not mixed

10 Assembly use
 20 Education use
 30 Medical use
 33 Residential use
 51 Row of stores
 53 Enclosed mall
 58 Business & residential
 59 Office use
 60 Industrial use
 63 Military use
 65 Farm use
 00 Other mixed use

J Property Use Star None

Structures

131 Church, place of worship
 161 Restaurant or cafeteria
 162 Bar/Tavern or nightclub
 213 Elementary school, kindergarten
 215 High school, junior high
 241 College, adult education
 311 Nursing home
 331 Hospital

Outside

124 Playground or park
 655 Crops or orchard
 669 Forest (timberland)
 807 Outdoor storage area
 919 Dump or sanitary landfill
 931 Open land or field

341 Clinic, clinic-type infirmary
 342 Doctor/Dentist office
 361 Prison or jail, not juvenile
 419 1- or 2-family dwelling
 429 Multifamily dwelling
 439 Rooming/Boarding house
 449 Commercial hotel or motel
 459 Residential, board and care
 464 Dormitory/Barracks
 519 Food and beverage sales

936 Vacant lot
 938 Graded/Cared for plot of land
 946 Lake, river, stream
 951 Railroad right-of-way
 960 Other street
 961 Highway/Divided highway
 962 Residential street/driveway

539 Household goods, sales, repairs
 571 Gas or service station
 579 Motor vehicle/boat sales/repairs
 599 Business office
 615 Electric-generating plant
 629 Laboratory/Science laboratory
 700 Manufacturing plant
 819 Livestock/Poultry storage (barn)
 882 Non-residential parking garage
 891 Warehouse

981 Construction site
 984 Industrial plant yard

Look up and enter a Property Use code and description only if you have NOT checked a Property Use box.

Property Use Code

K1 Person/Entity Involved

Local Option

Business Name (if applicable) _____ Area Code _____ Phone Number _____

Check this box if same address as incident location (Section B). Then skip the three duplicate address lines.

Mr., Ms., Mrs. First Name _____ MI _____ Last Name _____ Suffix _____

Number _____ Prefix _____ Street or Highway _____ Street Type _____ Suffix _____



Post Office Box _____ Apt./Suite/Room _____ City _____

State _____ ZIP Code _____ - _____

More people involved? Check this box and attach Supplemental Forms (NFIRS-1S) as necessary.

K2 Owner

Local Option

Same as person involved? Then check this box and skip the rest of this block.

Business Name (if applicable) _____ Area Code _____ Phone Number _____

Check this box if same address as incident location (Section B). Then skip the three duplicate address lines.

Mr., Ms., Mrs. First Name _____ MI _____ Last Name _____ Suffix _____

Number _____ Prefix _____ Street or Highway _____ Street Type _____ Suffix _____



Post Office Box _____ Apt./Suite/Room _____ City _____

State _____ ZIP Code _____ - _____



Remarks:

Local Option

Fire Module Required?

Check the box that applies and then complete the Fire Module based on Incident Type, as follows:

- Buildings 111 Complete Fire & Structure Modules
- Special structure 112 Complete Fire Module & Section I, Structure Module
- Confined 113-118 Basic Module Only
- Mobile property 120-123 Complete Fire & Structure Modules
- Vehicle 130-138 Complete Fire Module
- Vegetation 140-143 Complete Fire or Wildland Module
- Outside rubbish fire 150-155 Basic Module Only
- Special outside fire 160 Complete Fire or Wildland Module
- Special outside fire 161-164 Complete Fire Module
- Crop fire 170-173 Complete Fire or Wildland Module



ITEMS WITH A ★ MUST ALWAYS BE COMPLETED!

More remarks? Check this box and attach Supplemental Forms (NFIRS-1S) as necessary.

M Authorization

Check box if same as Officer in charge

Officer in charge ID _____ Signature _____ Position or rank _____ Assignment _____ Month _____ Day _____ Year _____

Member making report ID _____ Signature _____ Position or rank _____ Assignment _____ Month _____ Day _____ Year _____

A FDID State Incident Date MM DD YYYY Station Incident Number Exposure Delete Change **NFIRS-2 Fire**

B Property Details

B1 Not Residential
Estimated number of residential living units in building of origin *whether or not all units became involved.*

B2 Buildings not involved
Number of buildings involved

B3 None Less than one acre
Acres burned (outside fires)

C On-Site Materials or Products None
Complete if there were any significant amounts of commercial, industrial, energy, or agricultural products or materials on the property, *whether or not they became involved.*

Enter up to three codes. Check one box for each code entered.

On-site material (1)

On-site material (2)

On-site material (3)

On-Site Materials Storage Use

1 Bulk storage or warehousing
2 Processing or manufacturing
3 Packaged goods for sale
4 Repair or service
U Undetermined

D Ignition

D1 Area of fire origin

D2 Heat source

D3 Item first ignited Check box if fire spread was confined to object of origin.

D4 Type of material first ignited Required only if item first ignited code is 00 or <70.

E1 Cause of Ignition Check box if this is an exposure report.

1 Intentional
2 Unintentional
3 Failure of equipment or heat source
4 Act of nature
5 Cause under investigation
U Cause undetermined after investigation

E2 Factors Contributing to Ignition None

Factor contributing to ignition (1)

Factor contributing to ignition (2)

E3 Human Factors Contributing to Ignition None

Check all applicable boxes

1 Asleep None
2 Possibly impaired by alcohol or drugs
3 Unattended person
4 Possibly mentally disabled
5 Physically disabled
6 Multiple persons involved
7 Age was a factor

Estimated age of person involved

1 Male 2 Female

F1 Equipment Involved in Ignition None If equipment was not involved, skip to Section G.

Equipment Involved

Brand

Model

Serial #

Year

F2 Equipment Power Source

Equipment Power Source

F3 Equipment Portability

1 Portable
2 Stationary

Portable equipment normally can be moved by one or two persons, is designed to be used in multiple locations, and requires no tools to install.

G Fire Suppression Factors None

Enter up to three codes.

Fire suppression factor (1)

Fire suppression factor (2)

Fire suppression factor (3)

H1 Mobile Property Involved None

1 Not involved in ignition, but burned
2 Involved in ignition, but did not burn
3 Involved in ignition and burned

Mobile property model

License Plate Number State VIN Year

Structure fire? Please be sure to complete the Structure Fire form (NFIRS-3).

H2 Mobile Property Type and Make

Mobile property type

Mobile property make

Local Use

Pre-Fire Plan Available
Some of the information presented in this report may be based upon reports from other agencies:

Arson report attached
 Police report attached
 Coroner report attached
 Other reports attached

NFIRS-2 Revision 01/01/05

<p>I1 Structure Type ☆</p> <p>If fire was in an enclosed building or a portable/mobile structure, complete the rest of this form.</p> <p>1 <input type="checkbox"/> Enclosed building</p> <p>2 <input type="checkbox"/> Portable/mobile structure</p> <p>3 <input type="checkbox"/> Open structure</p> <p>4 <input type="checkbox"/> Air-supported structure</p> <p>5 <input type="checkbox"/> Tent</p> <p>6 <input type="checkbox"/> Open platform (e.g., piers)</p> <p>7 <input type="checkbox"/> Underground structure (work areas)</p> <p>8 <input type="checkbox"/> Connective structure (e.g., fences)</p> <p>0 <input type="checkbox"/> Other type of structure</p>	<p>I2 Building Status ☆</p> <p>1 <input type="checkbox"/> Under construction</p> <p>2 <input type="checkbox"/> In normal use</p> <p>3 <input type="checkbox"/> Idle, not routinely used</p> <p>4 <input type="checkbox"/> Under major renovation</p> <p>5 <input type="checkbox"/> Vacant and secured</p> <p>6 <input type="checkbox"/> Vacant and unsecured</p> <p>7 <input type="checkbox"/> Being demolished</p> <p>0 <input type="checkbox"/> Other</p> <p>U <input type="checkbox"/> Undetermined</p>	<p>I3 Building Height ☆</p> <p>Count the roof as part of the highest story.</p> <p>_____</p> <p>Total number of stories at or above grade.</p> <p>_____</p> <p>Total number of stories below grade.</p>	<p>I4 Main Floor Size ☆</p> <p>NFIRS-3 Structure Fire</p> <p>_____, _____, _____</p> <p>Total square feet</p> <p>OR</p> <p>_____, _____ BY _____, _____</p> <p>Length in feet Width in feet</p>
---	---	--	--

<p>J1 Fire Origin ☆</p> <p>_____</p> <p>Story of fire origin</p> <p><input type="checkbox"/> Below grade</p>	<p>J3 Number of Stories Damaged by Flame</p> <p>Count the roof as part of the highest story.</p> <p>_____</p> <p>Number of stories w/minor damage (1 to 24% flame damage)</p> <p>_____</p> <p>Number of stories w/significant damage (25 to 49% flame damage)</p> <p>_____</p> <p>Number of stories w/heavy damage (50 to 74% flame damage)</p> <p>_____</p> <p>Number of stories w/extreme damage (75 to 100% flame damage)</p>	<p>K Type of Material Contributing Most to Flame Spread</p> <p><input type="checkbox"/> Check if no flame spread OR if same as Material First Ignited (Block D4, Fire Module) OR if unable to determine. → Skip to Section L</p> <p>K1 _____</p> <p>Item contributing most to flame spread</p> <p>K2 _____</p> <p>Type of material contributing most to flame spread Required only if item contributing code is 00 or <70.</p>
<p>J2 Fire Spread ☆</p> <p>If fire spread was confined to object of origin, do not check a box (Ref. Block D3, Fire Module).</p> <p>2 <input type="checkbox"/> Confined to room of origin</p> <p>3 <input type="checkbox"/> Confined to floor of origin</p> <p>4 <input type="checkbox"/> Confined to building of origin</p> <p>5 <input type="checkbox"/> Beyond building of origin</p>		

<p>L1 Presence of Detectors ☆</p> <p>(In area of the fire)</p> <p>N <input type="checkbox"/> None Present → Skip to Section M</p> <p>1 <input type="checkbox"/> Present</p> <p>U <input type="checkbox"/> Undetermined</p>	<p>L3 Detector Power Supply</p> <p>1 <input type="checkbox"/> Battery only</p> <p>2 <input type="checkbox"/> Hardwire only</p> <p>3 <input type="checkbox"/> Plug-in</p> <p>4 <input type="checkbox"/> Hardwire with battery</p> <p>5 <input type="checkbox"/> Plug-in with battery</p> <p>6 <input type="checkbox"/> Mechanical</p> <p>7 <input type="checkbox"/> Multiple detectors & power supplies</p> <p>0 <input type="checkbox"/> Other</p> <p>U <input type="checkbox"/> Undetermined</p>	<p>L5 Detector Effectiveness</p> <p>Required if detector operated.</p> <p>1 <input type="checkbox"/> Alerted occupants, occupants responded</p> <p>2 <input type="checkbox"/> Alerted occupants, occupants failed to respond</p> <p>3 <input type="checkbox"/> There were no occupants</p> <p>4 <input type="checkbox"/> Failed to alert occupants</p> <p>U <input type="checkbox"/> Undetermined</p>
<p>L2 Detector Type</p> <p>1 <input type="checkbox"/> Smoke</p> <p>2 <input type="checkbox"/> Heat</p> <p>3 <input type="checkbox"/> Combination smoke and heat</p> <p>4 <input type="checkbox"/> Sprinkler, water flow detection</p> <p>5 <input type="checkbox"/> More than one type present</p> <p>0 <input type="checkbox"/> Other</p> <p>U <input type="checkbox"/> Undetermined</p>	<p>L4 Detector Operation</p> <p>1 <input type="checkbox"/> Fire too small to activate</p> <p>2 <input type="checkbox"/> Operated → Complete Block L5</p> <p>3 <input type="checkbox"/> Failed to operate → Complete Block L6</p> <p>U <input type="checkbox"/> Undetermined</p>	<p>L6 Detector Failure Reason</p> <p>Required if detector failed to operate.</p> <p>1 <input type="checkbox"/> Power failure, shutoff, or disconnect</p> <p>2 <input type="checkbox"/> Improper installation or placement</p> <p>3 <input type="checkbox"/> Defective</p> <p>4 <input type="checkbox"/> Lack of maintenance, includes not cleaning</p> <p>5 <input type="checkbox"/> Battery missing or disconnected</p> <p>6 <input type="checkbox"/> Battery discharged or dead</p> <p>0 <input type="checkbox"/> Other</p> <p>U <input type="checkbox"/> Undetermined</p>

<p>M1 Presence of Automatic Extinguishing System ☆</p> <p>N <input type="checkbox"/> None Present → Complete rest of Section M</p> <p>1 <input type="checkbox"/> Present</p> <p>2 <input type="checkbox"/> Partial System Present</p> <p>U <input type="checkbox"/> Undetermined</p>	<p>M3 Operation of Automatic Extinguishing System</p> <p>Required if fire was within designed range.</p> <p>1 <input type="checkbox"/> Operated/effective (go to M4)</p> <p>2 <input type="checkbox"/> Operated/Not effective (go to M4)</p> <p>3 <input type="checkbox"/> Fire too small to activate</p> <p>4 <input type="checkbox"/> Failed to operate (go to M5)</p> <p>0 <input type="checkbox"/> Other</p> <p>U <input type="checkbox"/> Undetermined</p>	<p>M5 Reason for Automatic Extinguishing System Failure</p> <p>Required if system failed or not effective.</p> <p>1 <input type="checkbox"/> System shut off</p> <p>2 <input type="checkbox"/> Not enough agent discharged</p> <p>3 <input type="checkbox"/> Agent discharged but did not reach fire</p> <p>4 <input type="checkbox"/> Wrong type of system</p> <p>5 <input type="checkbox"/> Fire not in area protected</p> <p>6 <input type="checkbox"/> System components damaged</p> <p>7 <input type="checkbox"/> Lack of maintenance</p> <p>8 <input type="checkbox"/> Manual intervention</p> <p>0 <input type="checkbox"/> Other</p> <p>U <input type="checkbox"/> Undetermined</p>
<p>M2 Type of Automatic Extinguishing System</p> <p>Required if fire was within designed range of AES.</p> <p>1 <input type="checkbox"/> Wet-pipe sprinkler</p> <p>2 <input type="checkbox"/> Dry-pipe sprinkler</p> <p>3 <input type="checkbox"/> Other sprinkler system</p> <p>4 <input type="checkbox"/> Dry chemical system</p> <p>5 <input type="checkbox"/> Foam system</p> <p>6 <input type="checkbox"/> Halogen-type system</p> <p>7 <input type="checkbox"/> Carbon dioxide (CO₂) system</p> <p>0 <input type="checkbox"/> Other special hazard system</p> <p>U <input type="checkbox"/> Undetermined</p>	<p>M4 Number of Sprinkler Heads Operating</p> <p>Required if system operated.</p> <p>_____</p> <p>Number of sprinkler heads operating</p>	

A	FDID <input type="text"/> <input type="text"/> <input type="text"/> <input type="text"/> <input type="text"/> <input type="text"/>	State <input type="text"/> <input type="text"/>	Incident Date <input type="text"/> <input type="text"/> <input type="text"/> <input type="text"/> <input type="text"/> <input type="text"/>	Station <input type="text"/> <input type="text"/> <input type="text"/> <input type="text"/>	Incident Number <input type="text"/> <input type="text"/> <input type="text"/> <input type="text"/> <input type="text"/> <input type="text"/>	Exposure <input type="text"/> <input type="text"/> <input type="text"/> <input type="text"/>	<input type="checkbox"/> Delete <input type="checkbox"/> Change	NFIRS-4 Civilian Fire Casualty
----------	--	---	---	---	---	--	--	---

B Injured Person	C Casualty Number
Gender <input type="checkbox"/> Male <input type="checkbox"/> Female First Name <input type="text"/> <input type="text"/> <input type="text"/> <input type="text"/> <input type="text"/> <input type="text"/>	Casualty Number <input type="text"/> <input type="text"/> <input type="text"/> <input type="text"/>

D Age or Date of Birth	E1 Race	F Affiliation	H Severity
Age <input type="text"/> <input type="text"/> <input type="checkbox"/> Months (for infants) OR Date of Birth <input type="text"/> <input type="text"/> <input type="text"/> <input type="text"/> <input type="text"/> <input type="text"/>	1 <input type="checkbox"/> White 2 <input type="checkbox"/> Black, African American 3 <input type="checkbox"/> Am. Indian, Alaska Native 4 <input type="checkbox"/> Asian 5 <input type="checkbox"/> Native Hawaiian, Other Pacific Islander 0 <input type="checkbox"/> Other, multiracial U <input type="checkbox"/> Undetermined	1 <input type="checkbox"/> Civilian 2 <input type="checkbox"/> EMS, not fire department 3 <input type="checkbox"/> Police 0 <input type="checkbox"/> Other	1 <input type="checkbox"/> Minor 2 <input type="checkbox"/> Moderate 3 <input type="checkbox"/> Severe 4 <input type="checkbox"/> Life threatening 5 <input type="checkbox"/> Death U <input type="checkbox"/> Undetermined
	E2 Ethnicity	G Date and Time of Injury	
	1 <input type="checkbox"/> Hispanic or Latino 0 <input type="checkbox"/> Non Hispanic or Latino	Date of Injury <input type="text"/> <input type="text"/> <input type="text"/> <input type="text"/> <input type="text"/> <input type="text"/> Time of Injury <input type="text"/> <input type="text"/> <input type="text"/> <input type="text"/> <input type="text"/> <input type="text"/>	

I Cause of Injury	J Human Factors Contributing to Injury	K Factors Contributing to Injury
1 <input type="checkbox"/> Exposed to fire products including flame heat, smoke, and gas 2 <input type="checkbox"/> Exposed to toxic fumes other than smoke 3 <input type="checkbox"/> Jumped in escape attempt 4 <input type="checkbox"/> Fell, slipped, or tripped 5 <input type="checkbox"/> Caught or trapped 6 <input type="checkbox"/> Structural collapse 7 <input type="checkbox"/> Struck by or contact with object 8 <input type="checkbox"/> Overexertion or strain 9 <input type="checkbox"/> Multiple causes 0 <input type="checkbox"/> Other U <input type="checkbox"/> Undetermined	<input type="checkbox"/> None Check all applicable boxes 1 <input type="checkbox"/> Asleep 2 <input type="checkbox"/> Unconscious 3 <input type="checkbox"/> Possibly impaired by alcohol 4 <input type="checkbox"/> Possibly impaired by other drug 5 <input type="checkbox"/> Possibly mentally disabled 6 <input type="checkbox"/> Physically disabled 7 <input type="checkbox"/> Physically restrained 8 <input type="checkbox"/> Unattended person	<input type="checkbox"/> None Enter up to three contributing factors Contributing factor (1) <input type="text"/> <input type="text"/> <input type="text"/> <input type="text"/> Contributing factor (2) <input type="text"/> <input type="text"/> <input type="text"/> <input type="text"/> Contributing factor (3) <input type="text"/> <input type="text"/> <input type="text"/> <input type="text"/>

L Activity When Injured	M1 Location at Time of Incident	M3 Story at Start of Incident
1 <input type="checkbox"/> Escaping 2 <input type="checkbox"/> Rescue attempt 3 <input type="checkbox"/> Fire control 4 <input type="checkbox"/> Return to fire before control 5 <input type="checkbox"/> Return to fire after control 6 <input type="checkbox"/> Sleeping 7 <input type="checkbox"/> Unable to act 8 <input type="checkbox"/> Irrational act 0 <input type="checkbox"/> Other U <input type="checkbox"/> Undetermined	1 <input type="checkbox"/> In area of origin and not involved 2 <input type="checkbox"/> Not in area of origin and not involved 3 <input type="checkbox"/> Not in area of origin, but involved 4 <input type="checkbox"/> In area of origin and involved 0 <input type="checkbox"/> Other location U <input type="checkbox"/> Undetermined	Complete ONLY if injury occurred INSIDE Story at start of incident <input type="text"/> <input type="text"/> <input type="text"/> <input type="text"/> <input type="checkbox"/> Below grade
	M2 General Location at Time of Injury	M4 Story Where Injury Occurred
	1 <input type="checkbox"/> In area of fire origin → Skip to Section N 2 <input type="checkbox"/> In building, but not in area → Skip to Block M5 3 <input type="checkbox"/> Outside, but not in area U <input type="checkbox"/> Undetermined	Story where injury occurred, if different from M3 <input type="text"/> <input type="text"/> <input type="text"/> <input type="text"/> <input type="checkbox"/> Below grade
		M5 Specific Location at Time of Injury
		Complete ONLY if casualty NOT in area of origin Specific location at time of injury <input type="text"/> <input type="text"/> <input type="text"/> <input type="text"/>

N Primary Apparent Symptom	O Primary Area of Body Injured	P Disposition
01 <input type="checkbox"/> Smoke only, asphyxiation 11 <input type="checkbox"/> Burns and smoke inhalation 12 <input type="checkbox"/> Burns only 21 <input type="checkbox"/> Cut, laceration 33 <input type="checkbox"/> Strain or sprain 96 <input type="checkbox"/> Shock 98 <input type="checkbox"/> Pain only Look up a code only if the symptom is NOT found above Primary apparent symptom <input type="text"/> <input type="text"/>	1 <input type="checkbox"/> Head 2 <input type="checkbox"/> Neck and shoulder 3 <input type="checkbox"/> Thorax 4 <input type="checkbox"/> Abdomen 5 <input type="checkbox"/> Spine 6 <input type="checkbox"/> Upper extremities 7 <input type="checkbox"/> Lower extremities 8 <input type="checkbox"/> Internal 9 <input type="checkbox"/> Multiple body parts	<input type="checkbox"/> Transported to emergency care facility Remarks <input type="text"/> <input type="text"/> <input type="text"/> <input type="text"/> <input type="text"/> <input type="text"/> Local option <input type="text"/> <input type="text"/> <input type="text"/> <input type="text"/>

K1 Did protective equipment fail and contribute to the injury?

Please complete the remainder of this form ONLY if you answer YES.

Yes Y
No N

Equipment Sequence Number

NFIRS-5
Fire Service
Casualty

K2 Protective Equipment Item

Head or Face Protection

- 11 Helmet
- 12 Full face protector
- 13 Partial face protector
- 14 Goggles/eye protection
- 15 Hood
- 16 Ear protector
- 17 Neck protector
- 10 Other

Coat, Shirt, or Trousers

- 21 Protective coat
- 22 Protective trousers
- 23 Uniform shirt
- 24 Uniform T-shirt
- 25 Uniform trousers
- 26 Uniform coat or jacket
- 27 Coveralls
- 28 Apron or gown
- 20 Other

Boots or Shoes

- 31 Knee length boots with steel baseplate and steel toes
- 32 Knee length boots with steel toes only
- 33 3/4 length boots with steel baseplate and steel toes
- 34 3/4 length boots with steel toes only
- 35 Boots without steel baseplate and steel toes
- 36 Safety shoes with steel baseplate and steel toes
- 37 Safety shoes with steel toes only
- 38 Non-safety shoes
- 30 Other

Respiratory Protection

- 41 SCBA (demand) open circuit
- 42 SCBA (positive pressure) open circuit
- 43 SCBA closed circuit
- 44 Not self-contained
- 45 Cartridge respirator
- 46 Dust or particle mask
- 40 Other

Hand Protection

- 51 Firefighter gloves with wristlets
- 52 Firefighter gloves without wristlets
- 53 Work gloves
- 54 HazMat gloves
- 55 Medical gloves
- 50 Other

Special Equipment

- 61 Proximity suit for entry
- 62 Proximity suit for non-entry
- 63 Totally encapsulated, reusable chemical suit
- 64 Totally encapsulated, disposable chemical suit
- 65 Partially encapsulated, reusable chemical suit
- 66 Partially encapsulated, disposable chemical suit
- 67 Flash protection suit
- 68 Flight or jump suit
- 69 Brush suit
- 71 Exposure suit
- 72 Self-contained underwater breathing apparatus (SCUBA)
- 73 Life preserver
- 74 Life belt or ladder belt
- 75 Personal alert safety system (PASS)
- 76 Radio distress device
- 77 Personal lighting
- 78 Fire shelter or tent
- 79 Vehicle safety belt
- 70 Special equipment, other
- 00 Protective equipment, other

Was the failure of more than one item of protective equipment a factor in the injury? If so, complete an additional page of this form for each piece of failed equipment.

K3 Protective Equipment Problem

Check one box to indicate the main problem that occurred.

- 11 Burned
- 12 Melted
- 21 Fractured, cracked or broken
- 22 Punctured
- 23 Scratched
- 24 Knocked off
- 25 Cut or ripped
- 31 Trapped steam or hazardous gas
- 32 Insufficient insulation
- 33 Object fell in or onto equipment item
- 41 Failed under impact
- 42 Face piece or hose detached
- 43 Exhalation valve inoperative or damaged
- 44 Harness detached or separated
- 45 Regulator failed to operate
- 46 Regulator damaged by contact
- 47 Problem with admissions valve
- 48 Alarm failed to operate
- 49 Alarm damaged by contact
- 51 Supply cylinder or valve failed to operate
- 52 Supply cylinder/valve damaged by contact
- 53 Supply cylinder—insufficient air/oxygen
- 94 Did not fit properly
- 95 Not properly serviced or stored prior to use
- 96 Not used for designed purpose
- 97 Not used as recommended by manufacturer
- 00 Other equipment problem
- UU Undetermined

K4 Equipment Manufacturer, Model and Serial Number

Manufacturer

Model

Serial Number

A FDID Delete Change
 State Incident Date Station Incident Number Exposure

B Number of Patients Patient Number
 Use a separate form for each patient

C Date/Time Time Arrived at Patient Time of Patient Transfer
 Check if same date as Alarm date

D Provider Impression/Assessment Check one box only None/no patient or refused treatment

10 <input type="checkbox"/> Abdominal pain	18 <input type="checkbox"/> Chest pain	26 <input type="checkbox"/> Hypovolemia	34 <input type="checkbox"/> Sexual assault
11 <input type="checkbox"/> Airway obstruction	19 <input type="checkbox"/> Diabetic symptom	27 <input type="checkbox"/> Inhalation injury	35 <input type="checkbox"/> Sting/Bite
12 <input type="checkbox"/> Allergic reaction	20 <input type="checkbox"/> Do not resuscitate	28 <input type="checkbox"/> Obvious death	36 <input type="checkbox"/> Stroke/CVA
13 <input type="checkbox"/> Altered LOC	21 <input type="checkbox"/> Electrocutation	29 <input type="checkbox"/> OD/Poisoning	37 <input type="checkbox"/> Syncope
14 <input type="checkbox"/> Behavioral/Psych	22 <input type="checkbox"/> General illness	30 <input type="checkbox"/> Pregnancy/OB	38 <input type="checkbox"/> Trauma
15 <input type="checkbox"/> Burns	23 <input type="checkbox"/> Hemorrhaging/Bleeding	31 <input type="checkbox"/> Respiratory arrest	00 <input type="checkbox"/> Other
16 <input type="checkbox"/> Cardiac arrest	24 <input type="checkbox"/> Hyperthermia	32 <input type="checkbox"/> Respiratory distress	
17 <input type="checkbox"/> Cardiac dysrhythmia	25 <input type="checkbox"/> Hypothermia	33 <input type="checkbox"/> Seizure	

E1 Age or Date of Birth Months (for infants)
 Age OR Month Day Year

F1 Race
 1 White
 2 Black, African American
 3 Am. Indian, Alaska Native
 4 Asian
 5 Native Hawaiian, Other Pacific Islander
 0 Other, multiracial
 U Undetermined

G1 Human Factors Contributing to Injury None
 Check all applicable boxes
 1 Asleep
 2 Unconscious
 3 Possibly impaired by alcohol
 4 Possibly impaired by drug
 5 Possibly mentally disabled
 6 Physically disabled
 7 Physically restrained
 8 Unattended person

G2 Other Factors None
 If an illness, not an injury, skip G2 and go to H3
 1 Accidental
 2 Self-inflicted
 3 Inflicted, not self

E2 Gender
 1 Male 2 Female

F2 Ethnicity
 1 Hispanic or Latino
 2 Non Hispanic or Latino

H1 Body Site of Injury
 List up to five body sites

H2 Injury Type
 List one injury type for each body site listed under H1

H3 Cause of Illness/Injury
 Cause of illness/injury

I Procedures Used No treatment
 Check all applicable boxes

01 <input type="checkbox"/> Airway insertion	14 <input type="checkbox"/> Intubation (EGTA)
02 <input type="checkbox"/> Anti-shock trousers	15 <input type="checkbox"/> Intubation (ET)
03 <input type="checkbox"/> Assist ventilation	16 <input type="checkbox"/> IO/IV therapy
04 <input type="checkbox"/> Bleeding control	17 <input type="checkbox"/> Medications therapy
05 <input type="checkbox"/> Burn care	18 <input type="checkbox"/> Oxygen therapy
06 <input type="checkbox"/> Cardiac pacing	19 <input type="checkbox"/> OB care/delivery
07 <input type="checkbox"/> Cardioversion (defib) manual	20 <input type="checkbox"/> Prearrival instructions
08 <input type="checkbox"/> Chest/Abdominal thrust	21 <input type="checkbox"/> Restrain patient
09 <input type="checkbox"/> CPR	22 <input type="checkbox"/> Spinal immobilization
10 <input type="checkbox"/> Cricothyroidotomy	23 <input type="checkbox"/> Splinted extremities
11 <input type="checkbox"/> Defibrillation by AED	24 <input type="checkbox"/> Suction/Aspirate
12 <input type="checkbox"/> EKG monitoring	00 <input type="checkbox"/> Other
13 <input type="checkbox"/> Extrication	

J Safety Equipment None
 Used or deployed by patient. Check all applicable boxes.
 1 Safety/Seat belts
 2 Child safety seat
 3 Airbag
 4 Helmet
 5 Protective clothing
 6 Flotation device
 0 Other
 U Undetermined

K Cardiac Arrest None
 Check all applicable boxes
 1 Pre-arrival arrest?
 If pre-arrival arrest, was it:
 1 Witnessed?
 2 Bystander CPR?
 2 Post-arrival arrest?
 Initial Arrest Rhythm
 1 V-Fib/V-Tach
 0 Other
 U Undetermined

L1 Initial Level of Provider Star
 1 First Responder
 2 EMT-B (Basic)
 3 EMT-I (Intermediate)
 4 EMT-P (Paramedic)
 0 Other provider
 N No Training

L2 Highest Level of Care Provided On Scene None
 1 First Responder
 2 EMT-B (Basic)
 3 EMT-I (Intermediate)
 4 EMT-P (Paramedic)
 0 Other provider

M Patient Status
 1 Improved
 2 Remained same
 3 Worsened
 Check if:
 1 Pulse on transfer
 2 No pulse on transfer

N EMS Disposition Not transported
 1 FD transport to ECF
 2 Non-FD transport
 3 Non-FD trans/FD attend
 4 Non-emergency transfer
 0 Other

A FDID Star State Star Incident Date Star Station Incident Number Star Exposure Star Haz No. Star Delete Change **NFIRS-7 HazMat**

B HazMat ID UN Number DOT Hazard Classification CAS Registration Number Chemical Name Star

C1 Container Type <input type="checkbox"/> None <input type="checkbox"/> Container Type <div style="border: 1px solid black; padding: 5px; width: fit-content;"> More hazardous materials? Use additional sheets. </div>	C2 Estimated Container Capacity <input type="checkbox"/> , <input type="checkbox"/> , <input type="checkbox"/> <small>Capacity: by volume or weight</small>	D1 Estimated Amount Released <input type="checkbox"/> Star <input type="checkbox"/> , <input type="checkbox"/> , <input type="checkbox"/> <small>Amount released: by volume or weight</small>	E1 Physical State When Released 1 <input type="checkbox"/> Solid 2 <input type="checkbox"/> Liquid 3 <input type="checkbox"/> Gas U <input type="checkbox"/> Undetermined																											
	C3 Units: Capacity <small>Check one box</small> <table border="0"> <tr> <td>VOLUME</td> <td>WEIGHT</td> </tr> <tr> <td>11 <input type="checkbox"/> Ounces</td> <td>21 <input type="checkbox"/> Ounces</td> </tr> <tr> <td>12 <input type="checkbox"/> Gallons</td> <td>22 <input type="checkbox"/> Pounds</td> </tr> <tr> <td>13 <input type="checkbox"/> Barrels: 42 gal.</td> <td>23 <input type="checkbox"/> Grams</td> </tr> <tr> <td>14 <input type="checkbox"/> Liters</td> <td>24 <input type="checkbox"/> Kilograms</td> </tr> <tr> <td>15 <input type="checkbox"/> Cubic feet</td> <td>MICRO UNITS</td> </tr> <tr> <td>16 <input type="checkbox"/> Cubic meters</td> <td><input type="checkbox"/> Enter Code</td> </tr> </table>	VOLUME	WEIGHT	11 <input type="checkbox"/> Ounces	21 <input type="checkbox"/> Ounces	12 <input type="checkbox"/> Gallons	22 <input type="checkbox"/> Pounds	13 <input type="checkbox"/> Barrels: 42 gal.	23 <input type="checkbox"/> Grams	14 <input type="checkbox"/> Liters	24 <input type="checkbox"/> Kilograms	15 <input type="checkbox"/> Cubic feet	MICRO UNITS	16 <input type="checkbox"/> Cubic meters	<input type="checkbox"/> Enter Code	D2 Units: Released <small>Check one box</small> <table border="0"> <tr> <td>VOLUME</td> <td>WEIGHT</td> </tr> <tr> <td>11 <input type="checkbox"/> Ounces</td> <td>21 <input type="checkbox"/> Ounces</td> </tr> <tr> <td>12 <input type="checkbox"/> Gallons</td> <td>22 <input type="checkbox"/> Pounds</td> </tr> <tr> <td>13 <input type="checkbox"/> Barrels: 42 gal.</td> <td>23 <input type="checkbox"/> Grams</td> </tr> <tr> <td>14 <input type="checkbox"/> Liters</td> <td>24 <input type="checkbox"/> Kilograms</td> </tr> <tr> <td>15 <input type="checkbox"/> Cubic feet</td> <td>MICRO UNITS</td> </tr> <tr> <td>16 <input type="checkbox"/> Cubic meters</td> <td><input type="checkbox"/> Enter Code</td> </tr> </table>	VOLUME	WEIGHT	11 <input type="checkbox"/> Ounces	21 <input type="checkbox"/> Ounces	12 <input type="checkbox"/> Gallons	22 <input type="checkbox"/> Pounds	13 <input type="checkbox"/> Barrels: 42 gal.	23 <input type="checkbox"/> Grams	14 <input type="checkbox"/> Liters	24 <input type="checkbox"/> Kilograms	15 <input type="checkbox"/> Cubic feet	MICRO UNITS	16 <input type="checkbox"/> Cubic meters	<input type="checkbox"/> Enter Code
VOLUME	WEIGHT																													
11 <input type="checkbox"/> Ounces	21 <input type="checkbox"/> Ounces																													
12 <input type="checkbox"/> Gallons	22 <input type="checkbox"/> Pounds																													
13 <input type="checkbox"/> Barrels: 42 gal.	23 <input type="checkbox"/> Grams																													
14 <input type="checkbox"/> Liters	24 <input type="checkbox"/> Kilograms																													
15 <input type="checkbox"/> Cubic feet	MICRO UNITS																													
16 <input type="checkbox"/> Cubic meters	<input type="checkbox"/> Enter Code																													
VOLUME	WEIGHT																													
11 <input type="checkbox"/> Ounces	21 <input type="checkbox"/> Ounces																													
12 <input type="checkbox"/> Gallons	22 <input type="checkbox"/> Pounds																													
13 <input type="checkbox"/> Barrels: 42 gal.	23 <input type="checkbox"/> Grams																													
14 <input type="checkbox"/> Liters	24 <input type="checkbox"/> Kilograms																													
15 <input type="checkbox"/> Cubic feet	MICRO UNITS																													
16 <input type="checkbox"/> Cubic meters	<input type="checkbox"/> Enter Code																													

Complete the remainder of this form only for the first hazardous material involved in this incident.	F2 Population Density 1 <input type="checkbox"/> Urban 2 <input type="checkbox"/> Suburban 3 <input type="checkbox"/> Rural	G2 Area Evacuated <input type="checkbox"/> None 1 <input type="checkbox"/> Square feet <input type="checkbox"/> , <input type="checkbox"/> 2 <input type="checkbox"/> Blocks <small>Enter measurement</small> 3 <input type="checkbox"/> Square miles	H HazMat Actions Taken <small>Enter up to three actions taken</small> <input type="checkbox"/> Primary action taken (1) <input type="checkbox"/> Additional action taken (2) <input type="checkbox"/> Additional action taken (3)
	F1 Released From <small>Check all applicable boxes</small> <input type="checkbox"/> Below grade 1 <input type="checkbox"/> Inside/on structure <input type="checkbox"/> Story of release 2 <input type="checkbox"/> Outside of structure	G1 Area Affected 1 <input type="checkbox"/> Square feet 2 <input type="checkbox"/> Blocks 3 <input type="checkbox"/> Square miles <input type="checkbox"/> , <input type="checkbox"/> <small>Enter measurement.</small>	G3 Estimated Number of People Evacuated <input type="checkbox"/> , <input type="checkbox"/>

J Cause of Release <input type="checkbox"/> Star 1 <input type="checkbox"/> Intentional 2 <input type="checkbox"/> Unintentional release 3 <input type="checkbox"/> Container/Containment failure 4 <input type="checkbox"/> Act of nature 5 <input type="checkbox"/> Cause under investigation U <input type="checkbox"/> Cause undetermined after investigation	K Factors Contributing to Release <small>Enter up to three contributing factors</small> <input type="checkbox"/> Factor contributing to release (1) <input type="checkbox"/> Factor contributing to release (2) <input type="checkbox"/> Factor contributing to release (3)	L Factors Affecting Mitigation <input type="checkbox"/> None <small>Enter up to three factors or impediments that affected the mitigation of the incident.</small> <input type="checkbox"/> Factor or impediment (1) <input type="checkbox"/> Factor or impediment (2) <input type="checkbox"/> Factor or impediment (3)
--	--	---

M Equipment Involved in Release <input type="checkbox"/> None <input type="checkbox"/> Equipment involved in release Brand <input type="checkbox"/> Model <input type="checkbox"/> Serial # <input type="checkbox"/> Year <input type="checkbox"/>	N Mobile Property Involved in Release <input type="checkbox"/> None <input type="checkbox"/> Mobile property type <input type="checkbox"/> Mobile property make Model <input type="checkbox"/> Year <input type="checkbox"/> License plate number <input type="checkbox"/> State <input type="checkbox"/> DOT number/ ICC number <input type="checkbox"/>	O HazMat Disposition <input type="checkbox"/> Star 1 <input type="checkbox"/> Completed by fire service only 2 <input type="checkbox"/> Completed w/fire service present 3 <input type="checkbox"/> Released to local agency 4 <input type="checkbox"/> Released to county agency 5 <input type="checkbox"/> Released to State agency 6 <input type="checkbox"/> Released to Federal agency 7 <input type="checkbox"/> Released to private agency 8 <input type="checkbox"/> Released to property owner or manager
		P HazMat Civilian Casualties Deaths <input type="checkbox"/> Injuries <input type="checkbox"/> <small>NFIRS-7 Revision 01/01/06</small>

A

FDID State Incident Date MM DD YYYY Station Incident Number Exposure

Delete Change

NFIRS-8 Wildland Fire

B Alternate Location Specification

Enter Latitude/Longitude OR Township/Range/Section/Subsection Meridian if Section B on the Basic Module is not completed.

Latitude Longitude

OR

Township Range Section Subsection Meridian

North South East West

C Area Type

1 Rural, farms >50 acres
 2 Urban (heavily populated)
 3 Rural/Urban or suburban
 4 Urban-wildland interface area

D1 Wildland Fire Cause

1 Natural source
 2 Equipment
 3 Smoking
 4 Open/Outdoor fire
 5 Debris/Vegetation burn
 6 Structure (exposure)
 7 Incendiary

8 Misuse of fire
 0 Other
 U Undetermined

D2 Human Factors Contributing to Ignition

Check as many boxes as are applicable. None

1 Asleep
 2 Possibly impaired by alcohol or drugs
 3 Unattended person
 4 Possibly mentally disabled
 5 Physically disabled
 6 Multiple persons involved
 7 Age was a factor

D3 Factors Contributing to Ignition

#1 #2

D4 Fire Suppression Factors

Enter up to three factors

#1 #2 #3

E Heat Source

F Mobile Property Type

G Equipment Involved in Ignition

H Weather Information

NFDRS Weather Station ID

Weather Type Wind Direction

Wind Speed (mph) Air Temperature F° Check if negative

Relative Humidity Fuel Moisture Fire Danger Rating

I1 Number of Buildings Ignited

None

Number of buildings that were ignited in Wildland fire.

I2 Number of Buildings Threatened

None

Number of buildings that were threatened by Wildland fire but were not involved.

I3 Total Acres Burned

, , .

I4 Primary Crops Burned

Identify up to 3 crops if any crops were burned.

Crop 1

Crop 2

Crop 3

J Property Management

Indicate the percent of the total acres burned for each ownership type then check the ONE box to identify the property ownership at the origin of the fire. If the ownership at origin is Federal, enter the Federal Agency Code.

Ownership Undetermined % Total Acres Burned

Private

1 Tax paying %
 2 Non-tax paying %

Public

3 City, town, village, local %
 4 County or parish %
 5 State or province %
 6 Federal %
 Federal Agency Code

7 Foreign %
 8 Military %
 0 Other %

K NFDRS Fuel Model at Origin

Enter the code and the descriptor corresponding to the NFDRS Fuel Model at Origin.

L1 Person Responsible for Fire

1 Identified person caused fire
 2 Unidentified person caused fire
 3 Fire not caused by person

If person identified, complete the rest of Section L.

L2 Gender of Person Involved

1 Male
 2 Female

L3 Age or Date of Birth

Age in Years Date of Birth

OR / /

Month Day Year

L4 Activity of Person Involved

Activity of Person Involved

M Type of Right-of-Way

Required if less than 100 feet.

Feet Type of right-of-way

Horizontal distance from right-of-way

N Fire Behavior

These optional descriptors refer to observations made at the point of initial attack.

Feet
Elevation

Relative position on slope

Aspect

Feet
Flame length

Chains per Hour
Rate of spread

A FDID Star State Star Incident Date Star MM DD YYYY Station Incident Number Star Exposure Star Delete Change **NFIRS-11 Arson**

B Agency Referred To None Agency Name Their case number
 Number Prefix Street or Highway Street Type Suffix Their ORI
 Post Office Box Apt./Suite/Room City Their Federal Identifier (FID)
 State ZIP Code Agency phone number Their FDID

C Case Status
 1 Investigation open
 2 Investigation closed
 3 Investigation inactive
 4 Closed with arrest
 5 Closed with exceptional clearance

D Availability of Material First Ignited
 1 Transported to scene
 2 Available at scene
 U Unknown

E Suspected Motivation Factors Check up to three factors
 11 Extortion 12 Labor unrest 13 Insurance fraud 14 Intimidation 15 Void contract/lease 21 Personal
 22 Hate crime 23 Institutional 24 Societal 31 Protest 32 Civil unrest 41 Fireplay/Curiosity
 42 Vanity/Recognition 43 Thrills 44 Attention/Sympathy 45 Sexual excitement 51 Homicide 52 Suicide 53 Domestic violence
 54 Burglary 61 Homicide concealment 62 Burglary concealment 63 Auto theft concealment 64 Destroy records/evidence 00 Other suspected motivation UU Unknown motivation

F Apparent Group Involvement Check up to three factors None
 1 Terrorist group
 2 Gang
 3 Anti-government group
 4 Outlaw motorcycle organization
 5 Organized crime
 6 Racial/Ethnic hate group
 7 Religious hate group
 8 Sexual preference hate group
 0 Other group
 U Unknown

H Incendiary Devices CONTAINER No container
 Select one from each category
 11 Bottle (glass) 12 Bottle (plastic) 13 Jug
 14 Pressurized container 15 Can (not gas or fuel) 16 Gasoline or fuel can
 17 Box 00 Other Container UU Unknown

IGNITION/DELAY DEVICE No device
 11 Wick or fuse 12 Candle 13 Cigarette and matchbook 14 Electronic component 15 Mechanical device 16 Remote control
 17 Road flare/fuse 18 Chemical component 19 Trailer/Streamer 20 Open flame source 00 Other delay device UU Unknown

G1 Entry Method
 Entry Method

FUEL None
 11 Ordinary combustibles 12 Flammable gas 14 Ignitable liquid 15 Ignitable solid
 16 Pyrotechnic material 17 Explosive material 00 Other material UU Unknown

G2 Extent of Fire Involvement on Arrival
 Extent of Fire Involvement

I Other Investigative Information Check all that apply
 1 Code violations
 2 Structure for sale
 3 Structure vacant
 4 Other crimes involved
 5 Illicit drug activity
 6 Change in insurance
 7 Financial problem
 8 Criminal/Civil actions pending

J Property Ownership
 1 Private
 2 City, town, village, local
 3 County or parish
 4 State or province
 5 Federal
 6 Foreign
 7 Military
 0 Other

K Initial Observations Check all that apply
 1 Windows ajar 2 Doors ajar 3 Doors locked 4 Doors unlocked
 5 Fire department forced entry 6 Entry forced prior to FD arrival 7 Security system activated 8 Security system present (not activated)

L Laboratory Used Check all that apply None
 1 Local 2 State 3 ATF 4 FBI 5 Other Federal 6 Private

A Delete Change

FDID State Incident Date Station Incident Number Exposure

MM DD YYYY

K1 Person/Entity Involved

Local Option Business Name (if applicable) Area Code - Phone Number

Check this box if same address as incident location. Then skip these three duplicate address lines.

Mr., Ms., Mrs. First Name MI Last Name Suffix

Number Prefix Street or Highway Street Type Suffix

Post Office Box Apt./Suite/Room City

State ZIP Code

K1 Person/Entity Involved

Local Option Business Name (if applicable) Area Code - Phone Number

Check this box if same address as incident location. Then skip these three duplicate address lines.

Mr., Ms., Mrs. First Name MI Last Name Suffix

Number Prefix Street or Highway Street Type Suffix

Post Office Box Apt./Suite/Room City

State ZIP Code

K1 Person/Entity Involved

Local Option Business Name (if applicable) Area Code - Phone Number

Check this box if same address as incident location. Then skip these three duplicate address lines.

Mr., Ms., Mrs. First Name MI Last Name Suffix

Number Prefix Street or Highway Street Type Suffix

Post Office Box Apt./Suite/Room City

State ZIP Code

K1 Person/Entity Involved

Local Option Business Name (if applicable) Area Code - Phone Number

Check this box if same address as incident location. Then skip these three duplicate address lines.

Mr., Ms., Mrs. First Name MI Last Name Suffix

Number Prefix Street or Highway Street Type Suffix

Post Office Box Apt./Suite/Room City

State ZIP Code

K1 Person/Entity Involved

Local Option Business Name (if applicable) Area Code - Phone Number

Check this box if same address as incident location. Then skip these three duplicate address lines.

Mr., Ms., Mrs. First Name MI Last Name Suffix

Number Prefix Street or Highway Street Type Suffix

Post Office Box Apt./Suite/Room City

State ZIP Code

E3

Supplemental Special Studies

Local Option

**NFIRS-1S
Supplemental**

1
Special Study ID# Special Study Value

2
Special Study ID# Special Study Value

3
Special Study ID# Special Study Value

4
Special Study ID# Special Study Value

5
Special Study ID# Special Study Value

6
Special Study ID# Special Study Value

7
Special Study ID# Special Study Value

8
Special Study ID# Special Study Value

L

Remarks:

Local Option

APPENDIX F—Summary of First-Day Presentations and Discussion

Highlights from Yesterday's Discussion

- Recent studies confirm potential for rapid fire growth to cause significant fire losses in residences
- Time for RUF fueled fires to develop are on the same order as those required for fire departments to be notified and respond (implications for fire losses and fire fighter safety)
- Consensus that losses due to smoldering only RUF are small and nearly negligible (losses occur following transition to flaming)
- Statistics suggest that flaming ignition of RUF occurs in a number of ways and in total represent a significant but not dominant source of fire losses
- Direct measures are not available describing RUF as second (or higher) item ignited, but there may be approaches for estimating losses due to these ignitions
- There is justification for breaking down statistics into losses inside the room for fire origin and outside the room of fire origin



- Statistics describing the role of RUF inside the room of fire origin are somewhat limited due to a lack of information concerning fire growth within the room (events between ignition and fire leaving room are not well captured)
- Statistics concerning role of RUF on losses external to the room of fire origin appear to have a firmer foundation
- Approaches for filling in some data gaps and uncertainties were suggested.
 - Targeted special studies using one page data sheet
 - Informal questioning of people filling out INFIRS form to clarify how coding is being performed in the field
- There is a continuing need for characterizing number and characteristics of RUF in residence
- Prevention versus mitigation

