

Fire Suppression and Re-ignition Prevention in a Full-Scale Engine Nacelle Simulator

ANTHONY HAMINS, THOMAS CLEARY and JIANN YANG
Building and fire Research Laboratory
National Institute of Standards and Technology
Gaithersburg, MD 20899-8663

ABSTRACT

An analysis is presented on the full-scale fire suppression experiments conducted on the F-22 engine nacelle simulator at Wright Patterson Air Force Base. Experiments investigated the relative effectiveness of halogenated agents and solid propellant gas generators (SPGG) in suppressing a series of spray fires with and without a fuel re-ignition source. Several agents were tested including CF_3Br (halon 1301), C_2HF_5 (HFC-125), and two basic types of SPGG, including one that produced inert gases in conjunction with a fine solid particulate composed of K_2CO_3 and one that produced inert gases only.

The measured agent effectiveness was compared to the predicted effectiveness based on results from cup burner suppression experiments. Estimates of the suppression effectiveness of the SPGG were based on the effectiveness of the components of its effluent. The mass fraction of SPGG effluent required to extinguish heptane cup burner flames was estimated as 0.15 and 0.29 as compared to previously measured values of 0.14 and 0.28 for CF_3Br and C_2HF_5 , respectively. The predicted suppression requirements (relative to CF_3Br) agreed with the full-scale measurements within 35% for the halogenated compounds, whereas the SPGG performed as much as a factor of 3.3 better than predicted. This difference suggests that a large fraction of the SPGG performance may have been related to its fast deployment, which enhances flame straining and thereby reduces agent mass suppression requirements. The SPGG effluent that contained a significant percentage of K_2CO_3 particulate was particularly effective for re-ignition protection, a scenario that dominates agent mass requirements for the compressed halogenated liquids. In this case, the SPGG required 27 times less mass than CF_3Br .

INTRODUCTION

Halon 1301, or trifluorobromomethane (CF_3Br), has been used as a fire extinguishing agent in many applications because of its many positive attributes. Due to its high ozone depletion potential, however, its production has been terminated. In the search for a suitable replacement, novel types of agents are under development. One class of such devices is the solid propellant gas generator (SPGG), a device in which solid-phase combustion yields products which can be used for fire suppression* [1].

The key parameters that affect flame stability, control flame extinction and the prevention of re-ignition are agent effectiveness and flow field dynamics. Whereas there is a general understanding of the suppression mechanisms of gaseous agents, little has been published on SPGG effectiveness. Recently, the relative suppression effectiveness of a SPGG has been

measured in a well-controlled bench-scale experiments [2]. There are many types of SPGG, each with its own composition, packaging geometry, and ignition sequencing. It is expected that gas specie and particulate yields, particulate size distributions, exhaust temperatures, and the rate and duration of effluent generation will vary from one SPGG to another, and each of these parameters may impact SPGG effectiveness. Table 1 shows the species composition of the SPGG effluent for the formulations tested here. For interest, a hypothetical mixture of unfiltered effluent from SPGG 1 is also included. Several SPGG types from Manufacturer 1 were tested and all were assumed to have the same effluent composition [3]. The hot exhaust products were principally gaseous N_2 , CO_2 , and H_2O vapor and salt particulates. Table 1 shows that there was approximately one-third as much CO_2 , more than twice as much H_2O , and almost two-thirds as much N_2 produced in the SPGG 2 effluent than in the filtered SPGG 1 effluent. The SPGG 2 effluent is assumed to be unfiltered, so that it contains $K_2CO_3(s)$, whereas the filtered SPGG 1 effluent is assumed to contain trace amounts of particulate only. Particle size can influence suppression effectiveness [4]. The majority of the SPGG particulate is very small and it is assumed that the particulate is smaller than the critical diameter [4].

To investigate the suppression effectiveness of SPGG in a simulated F-22 engine nacelle, a series of full-scale fire experiments was undertaken utilizing the Wright Patterson Aircraft Engine Nacelle Test Facility. The experiments described here investigated the relative effectiveness of halogenated agents and SPGG in suppressing spray fires with and without a re-ignition source. Several SPGG types were tested, including one that produced inert gases and a fine solid particulate, and one with the particulate filtered, such that only inert gases were emitted.

Table 1 SPGG mole based fractional effluent composition.			
Species	filtered SPGG 1	Unfiltered SPGG 1	SPGG 2
CO_2	0.313	0.264	0.0917
H_2O	0.219	0.183	0.559
N_2	0.468	0.395	0.325
K_2CO_3	0*	0.158	0.0246
* assumed to be trace amounts only.			

* Certain commercial materials and equipment are identified in this report in order to specify adequately the procedure. In no case does such identification imply recommendation or endorsement by the National Institute of Standards and Technology, nor does it imply that the material or equipment is necessarily the best for the purpose.

Fire Safety in Engine Nacelles

In general, there are two categories of fire safety problems associated with engine nacelles, namely, fire suppression and prevention of re-ignition. The occurrence of ignition and flame extinction are both governed by the Damköhler number criteria, which represents the chemistry-flow interaction. For a critical value of the Damköhler number (Da), which is equal to the ratio of a characteristic flow time to a characteristic chemical reaction time, the flame will abruptly extinguish. For a different value of Da , the reactants will abruptly ignite [5]. Ignition is kinetically distinct from flame extinction. The temperature regimes are different as is the important chemistry. Re-ignition can only occur if the local fuel/air ratio is within the flammability limits. If an agent is present, or if the temperature or pressure change, then the flammability limits will shift. Experiments at NIST [6] investigating the suppression of baffle stabilized flames showed that agent suppression requirements were a function of two parameters; the free stream agent concentration and the characteristic agent entrainment time related to the free stream velocity and the baffle size. In an engine nacelle, agent suppression requirements are also affected by environmental conditions, such as the initial air and agent temperature, the nacelle pressure, fuel type, and so on.

Comparison of Agent Effectiveness: Suppression of Non-Premixed Flames

The cup burner has been commonly used by industry for comparing fire suppression efficiency of gaseous agents [7]. The burner is an over-ventilated co-flowing diffusion flame. The cup burner extinction experiment is conducted by quasi-statically adding agent to the oxidizer stream until the flame is extinguished. Agent concentration requirements in the cup burner have been shown to correspond to the extinction requirements in large fires under total flooding conditions [8]. However, there is no information regarding the suppression effectiveness of SPGG itself or the $K_2CO_3(s)$ particulate, a key component of the SPGG effluent, in a standard laminar diffusion flame. Fortunately, it is possible to estimate agent suppression requirements if the agent composition is known.

Table 2 shows literature values and estimates of agent suppression concentrations for heptane cup burner flames for the species N_2 , $H_2O(g)$, CO_2 , C_2HF_5 , CF_3Br , $K_2CO_3(s)$, and for the SPGG mixtures given in Table 1 which include the filtered SPGG 1 effluent with K_2CO_3 particulate removed (gas species only), the unfiltered effluent from SPGG 2 (consisting of gas species and K_2CO_3 particulates), and a hypothetical agent of unfiltered SPGG 1 effluent (with gas species and K_2CO_3 particulates). Agent concentrations in Table 2 are presented in terms of both mole (X_i) and mass (Y_i) percent of agent in the oxidizer stream. Agent concentration requirements for flame suppression were determined using the NASA CEC computer code and data base [9] using a critical temperature criteria for flame extinction [8]. The critical temperature ($1587^\circ C$) was determined from N_2 concentration requirements for suppression of heptane cup burner flames [6]. Heptane was selected because it is a pure fuel that is within 4% of JP8 (the fuel of interest) in terms of suppression effectiveness [10]. An estimate of the required concentration for H_2O was determined using the critical temperature criteria assuming that this agent acted thermally. The results for the other gaseous components of the filtered SPGG 1 effluent, namely CO_2 and N_2 , have been measured [6]. The concentration requirements for $K_2CO_3(s)$, which has unknown suppression effectiveness,

was estimated using the ratio of Ewing's [4] results for peak effectiveness of $K_2CO_3(s)$ and $NaHCO_3(s)$, in conjunction with cup burner results for $NaHCO_3(s)$ [6]. This calculation yields a mass fraction of 0.042, denoted in Table 2 as " $K_2CO_3(s)$ active". To determine an upper bound for the required agent concentration, $K_2CO_3(s)$ was also treated as an inert, resulting in a mass fraction required for extinction equal to 13% (by volume), more than a factor of three less effective than the active form of $K_2CO_3(s)$. The difference between the "chemically active" and the inert forms of $K_2CO_3(s)$ yielded an "effectiveness factor", which was used to estimate the required concentration of SPGG effluent for particulate containing mixtures with $K_2CO_3(s)$ considered chemically active. Assuming that $K_2CO_3(s)$ is chemically active as suggested by Ewing's experiments [4], the suppression effectiveness of K_2CO_3 is approximately 80% chemical and 20% physical, which is similar to the results for CF_3Br [8].

Estimates of the suppression effectiveness of the filtered SPGG 1 effluent were also determined using the method described by the weighting method of Saito et al. [11]. This method yielded a critical volume fraction of 0.28 for the filtered SPGG 1 effluent, in agreement with the CEC calculations (see Table 2). The fractional contribution (FC) of a constituent species to the suppression effectiveness of the SPGG mixture was calculated [11]. The largest contributor for SPGG 1 was N_2 (FC=0.40), followed by CO_2 (FC=0.38), whereas the largest contributor for SPGG 2 was K_2CO_3 particulate (FC=0.43), followed by H_2O (FC=0.34).

Table 2 shows that the concentration requirements for the filtered effluent from SPGG 1 are not unlike that of its inert constituents (see Table 1). $K_2CO_3(s)$ and the "active" $K_2CO_3(s)$ containing SPGG effluent, on the other hand, are predicted to be effective suppressants as compared to the inert agents. Chemically active $K_2CO_3(s)$ is predicted to be very effective, a factor of three times more effective on a mass basis than even CF_3Br . It is not surprising, therefore, that the filtered SPGG 1 effluent with K_2CO_3 particulate removed is calculated to be less effective than the unfiltered SPGG 2 with 2% (by moles) K_2CO_3 . The effectiveness of potassium containing agents has been demonstrated in methane/air diffusion flames [12]. Maximizing the K_2CO_3 concentration in the SPGG effluent should increase its effectiveness. Table 2 shows that the SPGG 2 ("active") propellant is predicted to be a factor of two less effective (on a mass basis) than the (hypothetical) unfiltered SPGG 1 effluent, which has a factor of three higher $K_2CO_3(s)$ concentration. Table 2 also lists the average molecular weight (M_i) of the agents including the SPGG effluent mixtures. The mass of agent in 1 kg of air required for suppression is equal to:

$$m_i = (Y_i / 1 - Y_i) [kg]$$

The number of moles of agent per kg of agent or propellant deployed (n_i) is defined as:

$$n_i = 1 \text{ kg} / M_i$$

Table 3 lists n_i and m_i and shows that the number of moles of the SPGG 1 was reduced by 16% when particulate (assumed to be K_2CO_3) was filtered from the effluent. The number of moles for SPGG 1 was approximately half that provided by the SPGG 2 effluent. The largest n_i was from SPGG 2, which was almost a factor of 6 larger than n_i from 1 kg of halon 1301, and a factor of 2 larger than the n_i from 1 kg of the SPGG 1. The value of n_i is an

Table 2 Agent requirements for suppression of heptane cup burner flames.				
Agent	M G/mole	X _i Mole %	Y _i Mass %	Reference
N ₂	28	32	31	1
H ₂ O(g)	18	27	19	estimate ²
CO ₂	44	23	32	1
C ₂ HF ₅	120	8.7	28	1
CF ₃ Br	149	3.1	14	1
NaHCO ₃ (s)	84	2.3	6.4	1
K ₂ CO ₃ (s)	138	3.1	13	estimate ²
K ₂ CO ₃ (s) ("active")	138	0.91	4.2	estimate ³
filtered SPGG 1	30.8	28	29	estimate ²
unfiltered SPGG 1	47.8	12	19	estimate ²
unfiltered SPGG 1 ("active")	47.8	5.0	8.0	estimate ⁴
SPGG 2	26.5	23	22	estimate ²
SPGG 2 ("active")	26.5	17	15	estimate ⁴
1. see Ref. [6]. 2. estimate based on a critical temperature criteria for extinction treating the agent as inert. 3. estimate based on Ref. 4. 4. estimate based on CEC calculation with an effectiveness factor to treat chemical effects.				

important consideration in the suppression effectiveness of an agent. The larger the value of n_i , the more air is displaced, and the more effective is an agent. The predicted effectiveness of an agent normalized relative to halon 1301 (E_p), is:

$$E_p = m_i/m_i(\text{halon})$$

where E_p is a prediction of the relative suppression effectiveness of an agent as compared to halon 1301 due to its composition in a cup burner flame, which is a low strain rate non-premixed flame [13]. From estimates of E_p it is possible to compare the predicted

suppression effectiveness of the SPGG formulations. The relative values of m_i or E_p in Table 3 suggest that the unfiltered (hypothetical) SPGG 1 would have been the most effective agent on a per kilogram basis, followed by halon 1301, SPGG 2, HFC-125, and the filtered SPGG 1. Filtering of SPGG 1 is expected to change its effectiveness from the most effective to the least effective of the agents.

Although E_p includes both chemical and physical suppression behavior, it does not include flow field effects, agent temperature effects, the rate of agent deployment, agent mixing and dispersion, the rate of phase changes, and so on. These transport and thermodynamic effects influence the suppression effectiveness of an agent and are very difficult to predict quantitatively.

Table 3 The mass of agent in 1 kg of air required for suppression (m_i), the moles of agent available per kilogram of agent (n_i) and the predicted mass-based agent effectiveness per kilogram of agent deployed (E_p).			
Agent	n_i (moles)	m_i (kg)	E_p
halon 1301	6.7	0.16±0.08	1.0±0.07
HFC-125	8.3	0.39±0.02	2.4±0.2
SPGG 2*	37.7	0.18±0.09	1.1±0.08
Filtered SPGG 1	17.6	0.41±0.02	2.6±0.2
unfiltered SPGG 1*	20.9	0.074±0.037	0.46±0.03
* K_2CO_3 assumed to be chemically active (see Table 2).			

EXPERIMENTAL CONDITIONS and PROCEDURES

Table 4 outlines the key experimental conditions used during the full-scale F-22 tests. Experimental conditions varied in terms of the fire zone location, air temperature, agent storage temperature, the hot bleed duct temperature, the inner-wall surface temperature of the nacelle, and the air flow. These conditions were selected as "worst-case", after approximately 20 series of suppression experiments were conducted investigating the impact of experimental conditions such as air temperature and air flow on suppressant mass requirements for HFC-125 [3].

Figure 1 is a schematic of the interior of the nacelle. A large amount of clutter was inside the nacelle, including fuel lines, electrical lines and components, hydraulic lines, structural ribs, and so on. The free stream cross sectional area varied from 0.5 m² to 0.1 m² due to blockage by the clutter. The agent delivery outlet was a single tube that was split into two branches

(each with a ≈ 2 cm diameter). One branch was directed downstream and the other was perpendicular to that direction. Ventilation air (1 to 10m/s) carried the agent from right to left in Figure 1. The fuel spray nozzles were directed downstream and the nozzles were located approximately ≈ 2 m downstream of the agent delivery tubing. In a real nacelle, a hot bleed air duct carries hot exhaust products from the combustor into the nacelle. In the simulator, a feedback thermocouple was held under a ring clamp on the downstream side of the simulated hot bleed air duct to insure that the duct surface temperature was maintained at a selected temperature (see Table 2). A portion of the fuel spray cloud emitted from the nozzle in Fire Zone 1 (Test 1) flowed 30 cm downstream, towards the hot bleed air duct (10 cm diameter) where re-ignition of the JP8 fuel spray occurred under certain conditions. Also, the spray flame in Test 1 heated the bleed air duct, causing it to supersede the baseline temperature (610°C in Test 1). Cleaning of the duct before measurements was standard practice, because the surface condition impacted the probability of re-ignition. The hot

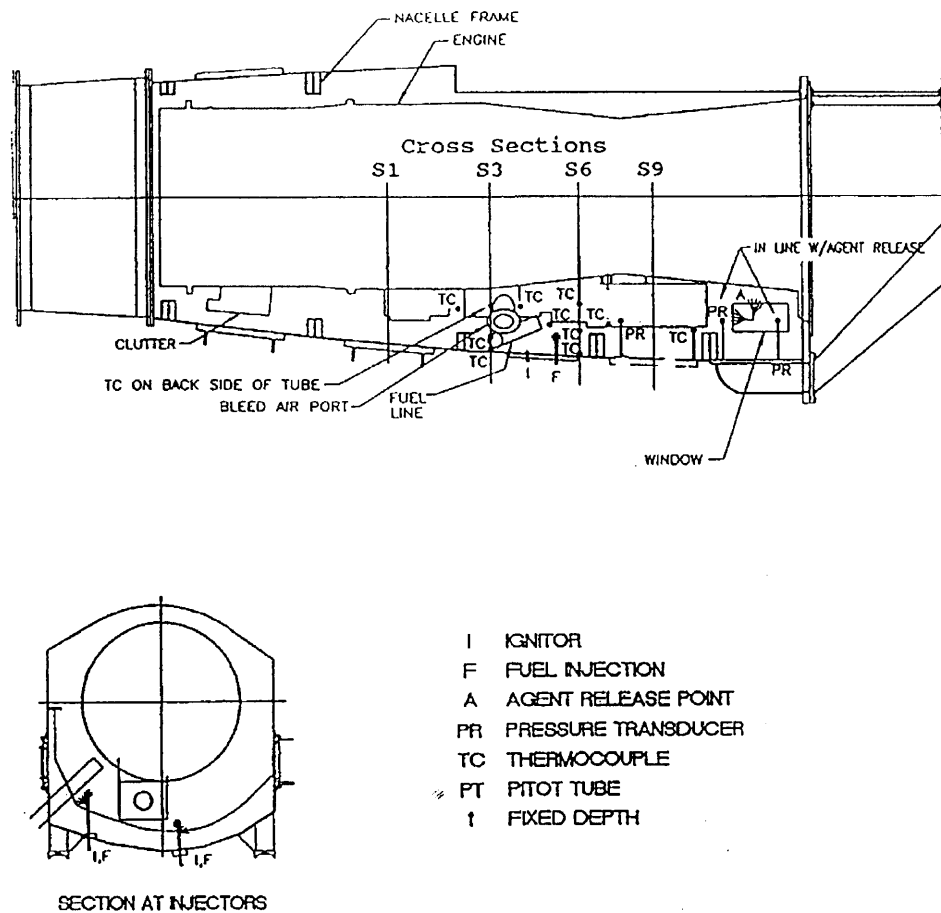

Figure 1. Side and cross-sectional views of the simulated F-22 engine nacelle.

bleed air duct was isolated from Fire Zone 2 during Tests 2 and 3, nor were there other components that might act as a re-ignition source for the fuel spray in Zone 2. The flow of the JP-8 spray was maintained at 600 ml/min, from a single nozzle, located in either Fire Zone 1 or Zone 2, as listed in Table 4. Pressure in the nacelle was nearly ambient.

A large number (≈ 400) full-scale suppression experiments were conducted to determine the critical agent mass required to achieve suppression and avoid re-ignition. The experimental protocol is described in detail elsewhere [3]. The spray flames were ignited for 20 s and agent was deployed. If suppression occurred, the fuel spray was maintained for 8 s. At that time, the occurrence of re-ignition was observed. If both fire suppression and prevention of re-ignition occurred, the test was considered successful. The experimental protocol stipulated that to be considered successful, suppression had to be achieved five times without failure for determination of the minimum required agent mass.

Concentration Measurements

To characterize agent dispersion, gas phase concentration measurements were made for non-combusting conditions corresponding to Test 1, just upstream of the hot bleed air duct. The rationale for using cold flow assumes that the upstream agent mixing behavior which controls suppression was largely unaffected by the fire or the momentum associated with the fuel spray. The concentration profiles for CF_3Br and HFC-125 were conducted using a Statham analyzer, which measures differential pressure across a critical flow orifice. Other experimental details are documented in Ref. 3.

Test	Fire Zone	T _{air} (°C)	T _{agent} (°C)	T _{duct} (°C)	T _{surf} (°C)	Airflow (kg/s)
1*	1	135	77	610	316	0.36
2	2	56	21	454	177	1.1
3	2	56	-40	232	27	1.1

* Tests 1-3 correspond to Tests 3, 13, and 16, respectively, in Ref. 3.

EXPERIMENTAL RESULTS

Table 5 shows the measured mass (and its uncertainty) required for fire suppression in Tests 1-3 for HFC-125, halon 1301, and SPGG. The uncertainty is due mainly to variability in the measurement of the mass, which is estimated as 5% for the compressed halogenated gases and 2 % for the SPGG. The values listed in Table 5 are initial propellant masses and do not include associated hardware. Complete propellant combustion is assumed. A comparison of the mass requirements for the halogenated agents suggests that the most challenging fire

scenario was Test 1, requiring the most agent mass. This is attributed to re-ignition of the fuel spray by the hot bleed air duct. In that experiment, the critical mass requirements for HFC-125 and halon 1301 were identical and greater than a factor of 5 and 28 over the SPGG mass requirements. Post-experiment examination of the hot bleed air duct after the SPGG2 tests showed that the duct was coated by particles, which may have prevented re-ignition of the JP8 fuel spray [14]. The particulate coating may have acted as an insulator, diminishing heat transfer and the temperature of gases near the bleed duct, or the particulate may have impacted heterogeneous reactions on the metal duct surface. Agent requirements in the other two experiments (Tests 2 and 3) were not driven by re-ignition. In those two experiments, the fuel spray was located in Zone 2, which was not directed towards the hot bleed air duct. The results in Table 5 suggest:

- halon 1301 was **not** more effective than HFC-125 in Test 1, a scenario driven by suppression of re-ignition. Halon was more effective in the other tests.
- the SPGG devices were more effective than halon except in Test 3, the cold flow condition (see Table 4) where halon 1301 was approximately as effective as SPGG2.
- SPGG 2 was generally more effective than SPGG 1, ostensibly due to the presence of particulate in the effluent (see Tables 1 and 3).
- the most challenging scenario for the SPGG 2 was for fires in Zone 2 (Tests 2 and 3). This was not true for SPGG 1.

Test	HFC-125 (kg)	halon 1301 (kg)	SPGG 1 (kg)	SPGG 2 (kg)
1	6.4±0.3	6.4±0.3	1.1±0.02	0.23±0.01
2	1.8±0.1	1.1±0.1	0.91±0.02	0.45±0.01
3	1.6±0.1	0.68±0.03	0.91±0.02	0.68±0.01

Mass Based Suppression Effectiveness

Table 6 lists the predicted and measured agent suppression effectiveness per mass (kg) of agent deployed normalized to halon 1301 for Tests 2 and 3. Results for Test 1 were not considered, because E_p pertains to flame suppression, not re-ignition prevention. The measured mass based agent effectiveness normalized to halon 1301 (E_m) was defined as: $E_m = (\text{Mass}_i / \text{Mass}_{\text{halon}})$, where Mass_i was the measured mass requirement for the i^{th} agent. The values of E_p are taken from Table 3. Values of E_m similar to E_p indicate that the agent performed as expected based on cup burner results, whereas a value of E_m less than E_p implies that the full-scale performance was superior to that expected from the cup burner. Table 6 shows that the value of E_p is similar to E_m for HFC-125 in Test 3, but beyond experimental uncertainty for Test 2. Table 6 shows that E_p was generally larger than E_m for the SPGG. This suggests that a large fraction of the SPGG performance may have been related to its fast deployment, which enhances flame straining. Agent mixing, dispersion, or thermodynamics could also have played a role. The value of E_p for the SPGG 1 assumes that

particulate was completely filtered from its effluent. For an unfiltered SPGG 1, $E_p = 0.46$. The measured agent requirement E_m for the SPGG1 fell between the filtered and unfiltered E_p values. From the values of E_p , SPGG2 was expected to be more effective than SPGG1, and this trend is evident in the data. The magnitude of this difference is smaller than expected. This may be due to some small amount of particulate escaping through the SPGG 1 filter system. Test 2, the moles of agent deployed were nearly equal for the two SPGG agents and the measured SPGG canister pressure traces showed that both agents were rapidly released in ≈ 0.5 s, implying that flame strain effects were similar.

Flame Stability and Fluid Temperature

Flame stability and agent mass requirements are impacted by the gas temperature just upstream of the flame anchoring location. Thermocouples were placed 10 cm upstream of the fuel nozzles in Fire Zones 1 and 2 during the SPGG testing. The temperature of the SPGG effluent at the nozzle exit was estimated as approximately 400°C near the nozzle exit [3]. But free stream thermocouple measurements just upstream of the fire zones showed that the increased temperature associated with SPGG was small (less than $\approx 30^\circ\text{C}$). This would have a very small effect on agent concentration requirements [3]. For regions very close to the nozzle exit, agent concentrations will be high and flame stabilization by elevated temperature effects will likely be unimportant.

	HFC-125	halon 1301	SPGG 1	SPGG 2
E_m : Exp. 2	1.6±0.1	1.0±0.07	0.83±0.04	0.41±0.02
E_m : Exp. 3	2.4±0.2	1.0±0.07	1.3±0.07	1.0±0.05
E_p : Predicted (see Table 3)	2.4±0.2	1.0±0.07	2.6±0.2 *	1.1±0.08
* assuming SPGG 1 is free of particulate; for unfiltered SPGG 1, $E_p = 0.46$ (Table 3)				

Re-ignition Prevention

Conditions that lead to re-ignition are controlled by the residence time and temperature of the reactive mixture and to a lesser extent by the type of metal surface and chemical composition of the fuel. Under certain conditions, when a hydrocarbon fuel spray was near the preheated hot bleed air duct, fire suppression and prevention of re-ignition required more than a factor of four more agent than if the hot surface were not present (see Tests 1, 2 and 3 in Table 5). Re-ignition was prevented only when large amounts of halogenated agent were applied, presumably due to inerting of the hot bleed duct for 8 s after agent release (the criteria used in the experimental protocol). Agent cooling of the hot metal surface (610°C) in Test 1 may also have played a role, but was not likely a significant mechanism in preventing re-ignition because the difference in temperature between the heated agent (77°C) and the hot air flow

itself (135°C) was small.

The surface temperature required to cause ignition of a reactant mixture is influenced by the concentration of a fire suppression agent. Inert agents, which are major constituents of SPGG, have a negligible effect on the ignition temperature of a hot metal surface, until the agent concentration is beyond the flammability limits and ignition simply does not occur [6].

Other strategies may exist to prevent re-ignition by a hot surface. For example, local application of a small amount of a condensed phase agent such as a liquid, foam, or powder directly on the hot surface could insulate the surface or diminish catalytic reactions on the metal surface. This phenomena was observed to occur in the case of the SPGG experiments, where $K_2CO_3(s)$ was observed to stick to the surface of the hot bleed air duct.

Table 5 shows that the HFC-125 and halon 1301 mass requirements were identical for Test 1, which highlights the mechanism for prevention of re-ignition. For the temperatures considered, the inerting concentration of halon 1301 is approximately a factor of two smaller than HFC-125 [3]. At ambient temperature, the inerting concentrations are 6% and 12% (by mole) for halon 1301 and HFC-125, respectively. Eight seconds after agent delivery, the agent concentrations in Fire Zone 1 for halon 1301 and for HFC-125 were measured as an average of 24% and 25% (by volume), well above the required inerting concentrations. (The agent concentration at 8 s is of interest because the test protocol defined suppression successful if the fire did not re-light for 8 s after suppression.) The results for SPGG were very different. In Test 1, the concentration 8 s after agent delivery for SPGG 1 and 2 were 14% and 1% on average (by volume) respectively, significantly below the inerting concentration, listed as 28% and 23% by volume for SPGG 1 and 2 in Table 2. Strain or enhanced velocity effects were unlikely to play a role in the ignition scenario, which is most likely to occur in the stagnation region on the downstream side of the hot bleed air duct. The effectiveness of SPGG 1 must be due to some small amount of particulate that escaped filtering and like the SPGG 2, acted on the surface of the hot bleed air duct. Visual observation indicated that a tiny amount of particulate was present in the SPGG1 effluent.

SUMMARY and CONCLUSIONS

A large number of fire suppression experiments were conducted in a simulated engine nacelle using SPGG and halogenated agents. The measured agent effectiveness was compared to the predicted effectiveness based on cup burner suppression experiments. Estimates of the suppression effectiveness of the SPGG devices were based on the effectiveness of its components. The mass fraction of SPGG effluent required to extinguish heptane cup burner flames was estimated as 0.15 and 0.29 as compared to previously measured values of 0.14 and 0.28 for CF_3Br and C_2HF_5 , respectively. The predicted suppression requirements (relative to CF_3Br) agreed with the full-scale measurements to within 35% for the halogenated compounds. The SPGGs performed as much as a factor of 3.3 better than predicted. This difference suggests that a large fraction of the SPGG performance may have been related to its fast deployment, which enhances flame straining and reduces agent mass

suppression requirements. The SPGG effluent that contained a significant percentage of K_2CO_3 particulate was particularly effective for re-ignition protection, a scenario that dominates agent mass requirements for the compressed halogenated liquids, requiring 27 times less agent by mass than CF_3Br .

Just as every halogenated agent has different properties, which affects its suppression effectiveness, every propellant formulation should be thought of as a distinct agent. Given its constituents and their effectiveness, it is possible to estimate the suppression effectiveness of the SPGG effluent mixture. It should be possible for a propellant manufacturer to maximize the effectiveness of the SPGG effluent composition. Agents that contain K_2CO_3 offer a mass efficient approach to re-ignition protection and fire suppression in an engine nacelle. Designing propellants doped with effective fire suppressant materials (e.g. Br, Na, Fe, etc.) could enhance the effectiveness of the current generation of SPGG.

REFERENCES

1. Yang, J.C. and Grosshandler, W.L. (Eds.), *Solid Propellant Gas Generators: Proceedings of the 1995 Workshop*, NISTIR 5766, 1995.
2. Grosshandler, W., Hamins, A., McGrattan, K., and Presser, C., "Transient Application, Recirculating Pool Fire, Agent Effectiveness Screen: Final Report, NGP Project 3A/2/890," NISTIR 6733, April 2001.
3. Hamins, A., Cleary, T., and Yang, J., "An Analysis of the Wright Patterson Full-Scale Engine Nacelle Fire Suppression Experiments", NISTIR 6193, November 1997.
4. Ewing, C.T., Faith, F.R., Romans, J.B., Hughes, J.T., and Carhart, H.W., J Fire Prot. Eng. **4**, 35-52 (1992).
5. Linan, A., *Acta Astronautica*, **1**, 1007 (1974).
6. Hamins, A., Cleary, T., Borthwick, P., Gorchkov, N., McGrattan, K., Forney, G., Grosshandler, W.L., Presser, C., and Melton, L., "Suppression of Engine Nacelle Fires," Section 9 in *Fire Suppression System Performance of Alternate Agents in Aircraft Engine and Dry Bay Laboratory Simulations* (Ed.:R.G. Gann) NIST Special Publication Number SP-890, 1995.
7. NFPA 2001 "Standard on Clean Agent Fire Extinguishing Systems," 2001 National Fire Codes, Vol. 10, NFPA, Quincy, MA.
8. Sheinson, R.S., Penner-Hahn, J.E., and Indritz, D., "The Physical and Chemical Action of Fire Suppressants," *Fire Safety Journal*, **15**, 43 (1989).
9. Gordon, S. and McBride, B.J., *Computer Program for Calculation of Complex Chemical Equilibrium Compositions, Rocket Performance, Incident and Reflected Shocks, and Chapman-Jouget Detonations*, NASA SP-273, 1976.
10. Hamins, A., Trees, D., Seshadri, K., and Chelliah, H.K., *Combust. Flame*, **99**, 221-230 (1994).
11. Saito, N., Ogawa, Y., Saso, Y., Liao, C., and Sakei, R., *Fire Safety J.*, **27**, 185-200, (1996).
12. Milne, T.A., Green, C. L., Benson, D.K., *Combust. Flame*, **15**, 255-264, (1970).
13. Hamins, A., Gmurczyk, G., Grosshandler, W., Rehwoldt, R.G., Vasquez, I., Cleary, T., Presser, C., and Seshadri, K., "Flame Suppression Effectiveness", Chap. 4 in (Grosshandler, W., Gann, R.G., Pitts, W.M., Eds.), NIST Special Publication Number SP-861, 1994.
14. Gillespie, M., Personal Communication, Wright Patterson Air Force Base, 1997.