

NBSIR 82-2507

Elevators As A Means of Fire Escape

**U.S. DEPARTMENT OF COMMERCE
National Bureau of Standards
National Engineering Laboratory
Center for Fire Research
Washington, DC 20234**

May 1982

**Sponsored by:
Office of Construction Research
Veterans Administration
Washington, DC 20420**

NBSIR 82-2507

ELEVATORS AS A MEANS OF FIRE ESCAPE

John H. Klote

U.S. DEPARTMENT OF COMMERCE
National Bureau of Standards
National Engineering Laboratory
Center for Fire Research
Washington, DC 20234

May 1982

Sponsored by:
Office of Construction Research
Veterans Administration
Washington, DC 20420



U.S. DEPARTMENT OF COMMERCE, Malcolm Baldrige, *Secretary*
NATIONAL BUREAU OF STANDARDS, Ernest Ambler, *Director*

TABLE OF CONTENTS

	Page
LISTOFFIGURES.	iv
LISTOFTABLES	iv
Abstract	1
1. INTRODUCTION	1
2. PROBLEMS WITH ELEVATORS	2
3. CONCEPTUAL SOLUTION	4
3.1 Elevator Controls	4
3.2 Electric Power	4
3.3 Fire and Smoke Protection	5
4. FIELD TESTS	5
4.1 Building 1	6
4.2 Building 2	7
4.2.1 Wing C	8
4.2.1.1 All Smoke Control systems Operating	8
4.2.1.2 Stairwell Pressurization and Elevator Shaft Pressurization Operating	9
4.2.1.3 Elevator Shaft Pressurization Operating	10
4.2.2 Wings B and D	10
4.2.2.1 Pressurized Stairwells	12
4.3 Building 3	12
4.4 Building 4	14
5. DISCUSSION AND CONCLUSIONS	16
6. FUTURE DIRECTION	17
7. ACKNOWLEDGEMENTS	17
8. REFERENCES	18

LIST OF FIGURES

	Page
Figure 1. Floor Plans for Building 1	20
Figure 2. Floor Plan for First Floor for Building 2	21
Figure 3. Typical Floor Plan above the First Floor for Building 2	22
Figure 4. First Floor Plan for Building 3	23
Figure 5. Typical Floor Plan above the First Floor for Building 3	24
Figure 6. Typical Floor Plan for Building 4	25

LIST OF TABLES

	Page
Table 1. Pressure Across Elevator Doors of Building 1	26
Table 2. Pressures in Wing C of Building 2 with all Smoke Control Systems Operating	27
Table 3. Pressures in Wing C of Building 2 with the Corridor Pressurization System Not Operating	28
Table 4. Pressures in Wing C of Building 2 with only the Elevator Shaft Pressurization	29
Table 5. Pressures in Wings B and D of Building 2	30
Table 6. Pressures in Building 3	31
Table 7. Pressures in Building 4	32

ELEVATORS AS A MEANS OF FIRE ESCAPE

John H. Klote

Abstract

This paper is the initial report of an ongoing project at NBS to investigate the use of elevators as a means of fire escape for the handicapped. The use of stairwells for fire evacuation poses a problem for people who cannot use stairs because of physical disabilities. This paper discusses some of the major problems associated with the use of elevators as a means of fire exit and proposes a conceptual solution to those problems. A report is made on field tests of four buildings with elevator protection systems. These protection systems and their interactions with other systems are examined.

Key Words: Building fires; elevators (lifts); egress; evacuation; handicapped; pressurization; smoke control; stairwells.

1. INTRODUCTION

In most elevator lobbies in the United States there are signs which have statements similar to the following:

- WARNING -

ELEVATOR SHALL NOT BE
USED IN THE EVENT OF FIRE

-

USE MARKED EXIT STAIRWAYS

Unfortunately some people cannot use stairs because of physical disabilities. Because of this problem, the Veterans Administration (VA) is sponsoring a project at National Bureau of Standards (NBS), Center for Fire Research (CFR) to investigate the feasibility of using elevators as a means of fire exit for the physically handicapped. This project consists of a field investigation stage and an analysis stage. The field tests are intended to provide information concerning the performance of systems intended for elevator protection. During the analysis stage the most promising protection systems will be analyzed in detail. The ultimate goal of this project is to provide information which can be used by building designers.

This paper contains a brief discussion of the problem, presentation of a conceptual solution, and a report of field tests on four buildings which have smoke control systems intended to protect elevators during fire situations. Some of the buildings tested had other types of smoke control systems in addition to systems for elevator protection. These systems are also discussed in terms of their interaction with the elevator protection system.

2. PROBLEMS WITH ELEVATORS

The National Fire Protection Association (NFPA) 101, Life Safety Code 1976 [1]¹ lists the following problems involved with the use of elevators as fire exits.

1. "Persons seeking to escape from a fire by means of an elevator may have to wait at the elevator door for some time, during which they **may** be exposed to fire or smoke, or panic may develop.

¹Numbers in brackets refer to the literature references listed at the end of this paper.

2. Automatic elevators respond to the pressing of buttons in such a way that it would be quite possible for an elevator in use for descent from floors above a fire to stop automatically at the floor involved in the fire and the doors to open automatically exposing occupants to fire and smoke.
3. Modern elevators cannot start until doors are fully closed. A large number of people seeking to crowd into an elevator in case of emergency might make it impossible to start.
4. Any power failure, such as the burning out of electric supply cables during a fire, may render the elevators inoperative or might result in trapping persons in elevators stopped between floors. Under fire conditions there might not be time to permit rescue of trapped occupants through emergency escape hatches or doors."

It is common practice for elevators serving more than three floors to automatically descend to the ground floor in the event of a fire². Fire fighters have keys with which they can manually control elevators and use them during building evacuation and fire fighting. However, smoke infiltration into elevator shafts frequently threatens life and hinders elevator use by fire fighters.

It is also current practice to top vent elevator shafts serving more than three floors³. The intent of such venting is to allow the elevator shaft to act as a smoke shaft carrying smoke from the fire floor out of the building. However, because of leakage around elevator doors this feature may significantly contribute to smoke movement into floors beyond the fire floor by way of the elevator shaft itself.

²The operation of elevators under fire conditions is mandated by section 211.3 of ANSI A17.1 [2].

³The requirement for vents in elevator shafts is listed in section 100.4 of ANSI A17.1 [2].

In Section 3 a conceptual method is presented to overcome the above problems and allow fire evacuation by means of elevators.

3. CONCEPTUAL SOLUTION

In order to overcome the problems discussed in the proceeding section, an elevator system used as a fire exit needs to have the following attributes:

1. Elevator control must assure safe and efficient evacuation.
2. Reliable electric power must be supplied.
3. Elevator lobbies and the elevator shaft must be protected against fire and smoke.

3.1 Elevator Controls

The elevator can be controlled so that it will descend to the ground in the event of a fire alarm. Fire department personnel or other authorized personnel can then use the elevators for evacuation. With the elevators controlled by authority figures, the likelihood that a large number of people would crowd into the elevator and make it impossible to close the doors will probably be reduced.

3.2 Electric Power

Considerable experience exists in assuring the supply of electrical power for critical functions in hospitals, communication facilities, computer facilities, and the like. The most common methods employed are emergency batteries, emergency generators, and multiple power feeds. While it is beyond the scope of this paper to examine methods of assuring power reliability, it appears that state-of-the-art solutions are available for elevator systems.

3.3 Fire and Smoke Protection

Considerable information is available concerning the fire resistance of walls, partitions, floors, doors, etc. The ability to design and build elevator lobbies and elevator shafts that can withstand severe building fires has existed for years. However, smoke protection is a more difficult problem.

Smoke movement can be controlled by the use of air flow and pressure differences. However, smoke control is a new field and no consensus has been reached as to what constitute reasonable air flows and pressure differences for elevator protection and further no accepted methods exist of achieving these air flows and pressure differences in the case of elevator protection. The development of this information is critical to the main goal of this project, i.e., to determine the feasibility of using elevators as a means of fire exit for the handicapped.

In implementing elevator shaft pressurization, the jamming of elevator doors in the open position can be a potential problem. The forces used to close the doors of automatic elevators are limited so as to prevent injury to any person who might be in the way of the doors. A differential pressure across the doors would add to the friction forces that the door closer must overcome. A sufficiently large differential pressure could cause an elevator to jam in the open position. During this initial series of field tests, the successful operation of elevator doors was observed for a range of differential pressures to provide some information regarding this concern.

4. FIELD TESTS

Field tests were performed in four buildings with pressurized elevator shafts. These tests form an initial screening of some existing systems, and the systems tested should not be considered model designs for smoke control. However, some useful insight into elevator shaft

pressurization can be gained from these tests. None of these elevators were intended for general evacuation but were intended for use by the fire department for rescue and fire fighting. Accordingly, none of these elevators were provided with a pressurized lobby.

In all of these tests the difference between the indoor and outdoor temperatures was very small. Also, during these tests the wind velocities were relatively calm and accordingly no wind data was taken. In general the pressure fluctuations due to the wind did not exceed 1.2 Pa (0.005 in H₂O) and so only average values of pressure difference are listed in the tables. There was one exception among the field tests where the fluctuation exceeded this level; this is specifically addressed in the discussion.

In all but one of the elevator shaft pressurization systems tested, the pressurization was by a propeller fan. This type of fan is usually intended to move a large quantity of air against a very low pressure head⁴. However, when a propeller fan operates at higher pressure heads the flow rate drops dramatically. For this reason, the actual flow rates of the fans in these tests were probably much lower than the rated capacities of the fans.

4.1 Building 1

The building 1 is a four story office building located in Ohio. The building shown in figure 1, has a four story elevator with two cabs which open onto an atrium. The elevator shaft **was** pressurized by a roof mounted propeller fan rated at 2000 l/s (4300 cfm) at 31 Pa (1/8 in H₂O) static pressure.

⁴General information concerning propeller fans and other fan types is provided by ASHRAE [3].

With all the elevator doors closed the pressurization **system** maintained differential pressures across the elevator shaft in the range of **3.0** to 5.0 Pa (0.012 to 0.02 in H_2O) as listed in table 1. In this paper, the phrase differential pressure across the elevator shaft means the pressure difference between the elevator shaft and the elevator lobby where a higher elevator shaft pressure is considered positive. While the pressurization system was operating, the elevator doors opened and closed normally. In addition, because the elevators are programmed to go to the ground floor during a fire alarm, the pressurization system was also tested with the elevator cabs at ground level and an elevator door open at ground level. Under this arrangement, no pressure differential could be measured across the elevator door (however, movement of cigarette smoke indicated that there was some air flow out of the shaft) ■

4.2 Building 2

The building 2 also located in Ohio is a motel consisting of four wings as shown in figures 2 and 3. The main lobby and front desk are located in wing A which is one story high. Wings B, C, and D contain the guest rooms. Wing C is four stories, and wings B and D are both seven stories.

Wings B, C, and D have pressurized stairwells, pressurized corridors, and pressurized elevator shafts. The concept behind pressurized stairwells is that pressurization can prevent smoke infiltration into the stairwell and thus the stairwell will be a smoke free means of fire exit (considerable information regarding pressurized stairwells is available in the literature; for example [4-9]). The concept of corridor pressurization is to prevent smoke infiltration to the corridor, again providing a **smoke** free means of fire exit. To date no research has been done on pressurized corridors.

These smoke control systems are intended to be activated only in the wing in which smoke is detected or in which sprinkler flow is detected. Automatic closing doors separate wing C from the other wings when the smoke control systems in wing C are activated. For this reason wing C was studied separately.

4.2.1 Wing C

All of the smoke control fans for wing C were roof mounted propeller fans. The corridor fan supplied air into a duct which supplied the corridors on each floor. This fan was rated at 1900 ℓ/s (4000 cfm). The stairwell fans were both located on top of the stair shaft and dumped air directly into the shaft. These fans were rated at 1900 ℓ/s (4000 cfm) each. The elevator fan, rated at 2300 ℓ/s (4800 cfm), supplies air to the top of the elevator shaft. The elevator shaft in wing C contained one cab but the shaft was sized so that another cab could be added.

4.2.1.1 All Smoke Control Systems Operating

With all three of the smoke control systems operating in wing C the pressure differential across the elevator and stairwell 1 are listed in table 2. The elevator pressurization system maintained differential pressures in the range of 16 to 12 Pa (0.065 to 0.050 in H_2O) across the elevator shaft when all elevator doors were closed. Throughout the tests the elevator doors opened and closed properly. The pressures across stairwell 2 were checked and determined to be in the same range as those across stairwell 1.

The elevator pressures were much higher for the test in this building than for the test in the building 1 (see table 1). Both systems are four stories and the pressurization fans were rated in the same range at 2000 ℓ/s (4300 cfm) for building 1 and 2300 ℓ/s (4800 cfm) for wing C. The major difference was that the building 1 shaft

had eight elevator doors and the **wing C** shaft only had **four** doors. This would suggest that the higher pressures across the elevator shaft in wing C were due to the lower leakage area of this shaft.

As in the case of the building **1**, tests were run with the elevator cab at the ground level (floor **1**) and with the elevator door open. In this situation there was a pressure difference of 1.7 Pa (0.007 in H₂O) across the elevator shaft at the second level. This is considerably better than the similar situation in the building **1** where no pressure difference could be measured.

The effect on the pressurized elevator shaft of opening a door to the pressurized stairwell was evaluated. As might be expected, opening a stairwell door on a particular floor reduced the level of elevator shaft pressurization on that floor. When the fourth floor stairwell door was opened the pressure difference across the fourth floor elevator shaft dropped from 16 to 7.5 Pa (0.065 to 0.030 in H₂O). When the same thing was done on the first floor the pressure difference across the elevator shaft dropped from 16 to 12 Pa (0.065 to 0.050 in H₂O). Therefore, the elevator shaft pressurization system successfully maintained positive pressurization with a stairwell door open and the elevator door closed. Other tests were made which determined that an open elevator door had no measurable effect on the stairwell pressurization system.

4.2.1.2 Stairwell Pressurization and Elevator Shaft Pressurization Operating

A test was performed with only the stairwell pressurization systems and the elevator shaft pressurization system operating, in order to determine the effect of shutting off the corridor pressurization system. The pressures for this test with all elevator doors closed are listed in table 3. It is apparent by comparing this data with that for the corridor system operating (table 2), that in general the corridor pressurization system had little effect on the performance of the

elevator shaft pressurization system. The exception to this was at the first floor where without corridor pressurization the elevator shaft pressure decreased from 16 Pa to 10 Pa (0.065 to 0.040 in H_2O). Due to the unknown nature of the flow paths throughout the building, it is difficult to determine the cause for this pressure drop on the first floor. It may have been due to an increase in the wind velocity or to a change in the building flow network. **One** possible change in the flow network could occur when the maid service opened the door to a guest room which had an open window. The decrease could **also** simply reflect a new steady state flow condition for the building.

4.2.1.3 Elevator Shaft Pressurization Operating

A test was made with only the elevator shaft pressurization operating to further evaluate the interaction between the different smoke control systems. The pressures for this test with all elevator doors closed are listed in table 4. By comparing these data with the tests when all the smoke control systems were on (table 2) and when the stairwell system was on (table 3), it is apparent that in general the operation of the other smoke control systems had minor effect on the performance of the elevator shaft pressurization system. An exception to this is at the fourth floor where the pressure dropped by 2 or 3 Pa (0.007 or 0.012 in H_2O) depending on with which test It is compared. It can also be noted that the pressure across the elevator shaft at the first floor was approximately the same with all three systems on or with only the elevator shaft system on. Again, these exceptions may be due to changes in the wind, changes in the building flow network, or simply reflect a new steady state flow condition.

4.2.2 Wings B and D

Wings B and D are both seven stories and are connected to each other at each floor by corridors without barriers to air or smoke movement. Automatic closing doors separated wing B from wings A and C. For these reasons wings B and D were tested together as one unit. The

elevator shaft pressurization system **was** tested with the **stairwells** and corridor systems on. The pressures, listed in table 5, were measured with the stairwell doors and elevator doors closed. It can be observed that the differential pressures across the elevator shafts varied considerably from floor to floor. For the elevator shaft in wing B the pressures ranged from **2.0** to 10. Pa (0.008 to 0.040 in H_2O). The range over which the elevator shaft in wing D varied was somewhat less, from 5.0 to **11. Pa** (**0.020** to 0.045 in H_2O).

In order to determine if these pressure differences changed with time, a number of the measurements were repeated. The new measurements agreed well with the data in table 5 except for floor 6 of the elevator in wing B. This had been the point of lowest pressure across the elevator at 2.0 Pa (0.008 in H_2O) in the initial measurements. It was remeasured in the range from 2.5 to **-2.5 Pa** (0.01 to -0.01 in H_2O). The negative pressure indicated the elevator shaft was at a lower pressure than the corridor. Such fluctuations between positive and negative pressure have been observed in previous field tests of pressurized stairwells [3] and were attributed to wind effects. However, the wind effects would not cause the elevator shaft pressures to vary from floor to floor to the extent discussed above.

It was thought that these variations in elevator shaft pressures might be due to a large air connection from the building to the outside at one or more floors. Wings B and D were checked for such connections. It was observed that a number of the guest room windows were open, but the doors from rooms to the corridor were closed. Therefore, no direct flow path from the corridors to the outside could be found. It can also be observed from figures 2 and 3 that these wings B and D are connected to wing A at the first floor and connected to wing C at floors 1 through 4. **These** connections and the open guest room windows resulted in a complicated flow network which obviously differed considerably from floor to floor. These differences could result in variations in the pressures across the elevator shafts from floor to floor.

4.2.2.1 Pressurized Stairwells

It can be observed from table 5 that the differential pressure across the stairwell doors was uniform over the height of the stairwells. It can also be observed that the level of pressurization was considerably higher for stairwell 5 than for the other three. This happened even though each of the stairwells was supplied by propeller fans rated at 3800 ℓ/s (8000 cfm). The cracks around the doors of stairwell 5 were small and the doors were not undercut. The doors to stairwells 3 and 4 were undercut approximately 16 mm (5/8 in). Based on previous studies, this increased leakage area can account for the lower pressures in stairwells 3 and 4. While the doors to stairwell 6 were as tight-fitting as those to stairwell 5, the exterior door to stairwell 6 had no latch and was held open by air pressure. When this exterior door was closed the leakage was similar to that in stairwell 5, and the pressure across stairwell 6 was measured to be 85 Pa (0.34 in H_2O) at the first floor door from the stairwell to the corridor.

4.3 Building 3

The building 3 is a 20 story apartment building used for student housing in Detroit, Michigan. Floor plans for the building are shown in figures 4 and 5. There is one elevator shaft with two cabs. The elevator is pressurized from the top by a propeller fan rated to supply 8000 ℓ/s (17000 cfm) at 62 Pa (1/4 in H_2O) static pressure. Continuous corridor pressurization is obtained by a system which supplies conditioned air into the corridor on each floor. This conditioned air is supplied by a roof mounted air handling unit with a supply fan rated at 14000 ℓ/s (30000 cfm) at 560 Pa (2-1/4 in H_2O) static pressure. The building plans indicated that the stairwells were also pressurized by propeller fans; however, these fans were installed backwards, which would result in exhausting rather than pressurizing the stairwells⁵.

⁵Maintenance personnel at building 3 stated that arrangements were underway to correct this problem.

For this reason, these fans were not operated during these tests; however, the corridor pressurization system was operating throughout the tests.

Table 6 lists the pressures across the elevator with the elevator shaft unpressurized and pressurized. With the elevator shaft unpressurized, the upper floors of the shaft had positive pressures and the lower floors had negative pressures. This indicates that air was flowing into the shaft at the bottom and out of the shaft at the top. This flow is referred to as stack effect and frequently occurs when the building temperature is greater than the outside temperature. However, during this test the building temperature was 2°C (3.6°F) below the outside temperature. Obviously, other driving forces must have existed.

As might be expected, when the elevator pressurization system was on, the level of pressurization increased with building height (table 6). The elevator shaft pressurization system failed to maintain positive pressurization at the basement and first floor. Therefore, in the event of a fire on one of these levels the smoke would infiltrate the shaft, and the smoke would then be distributed by the elevator shaft throughout the building.

At a number of times during these tests a direct air connection existed from the building to the outside for a short period of time. On the first floor this resulted from opening the ground floor door. On the other floors it occurred as a result of having an open door to an apartment which also had an open balcony door to the outside. Specific data for such occurrences are listed as notes to table 6. As expected, in all cases the pressure across the elevator shaft increased at the floor with the direct air connection to the outside.

4.4 Building 4

The building 4 is a 12 story apartment building for the aged in Detroit, Michigan. Figure 6 is a typical floor plan for this building. The building has one elevator shaft with two cabs. Unlike any of the other test buildings discussed in this paper, building 4 has automatic closing doors which separate the elevator lobby from other building spaces. The building was equipped with pressurization systems for the stairwells and elevator shaft and with unique smoke control capabilities for the corridors.

Both stairwells and elevator shafts have their own specially dedicated pressurization fans located at ground level. These three fans were centrifugal type rated at 440 ℓ/s (930 cfm) at a static pressure of 370 Pa (1.5 in H_2O). From experience, it was apparent that these fan capacities were too low, and therefore they would have almost no pressurizing effect for the stairwells or the elevator shaft.

The corridor smoke control consisted of a corridor supply system and two corridor exhaust systems. Conditioned air was continuously supplied to the corridors from a roof mounted air handling unit. The supply fan was a centrifugal type rated at 12,300 ℓ/s (26,100 cfm) at 311 Pa (1.25 in H_2O) of static pressure. The supply air was distributed through a vertical duct which dumped air into a plenum over the elevator lobby. Air from the plenum was supplied directly to the corridors on either side of the elevator lobby. Upon inspection of the building it was found that air from the plenum on each floor was leaking through cracks around door frames, lights and electric switches into the elevator lobby.

The two corridor exhaust systems were designed so that they could exhaust air on the fire floor from either side of the elevator lobby. Each corridor exhaust system had a roof mounted exhaust fan rated at 2000 ℓ/s (4300 cfm) at 93 Pa (3/8 in H_2O) of static pressure. Each exhaust fan was connected to a vertical exhaust duct (see figure 6)

connected to the corridor at each floor. Behind the exhaust grilles on each floor was a normally closed damper. In the event of a fire alarm the procedure for activation of the smoke control systems entail the following events:

1. The stairwell pressurization systems are activated.
2. The elevator pressurization system is activated.
3. The roof mount corridor exhaust fans are activated.
4. The normally closed dampers of the corridor exhaust system are opened only on the floor from which the fire alarm originated.

Events 3 and 4 above result in practically all of the capacity of exhaust fans being concentrated on the floor where the fire alarm originated. The concept behind use of these exhaust systems was to exhaust smoke from the fire floor and to create a level of pressurization on non-fire floors to prevent vertical smoke movement within the building. A problem with exhausting air from the fire floor corridor is that the exhaust might pull smoke from an apartment into the corridor and thereby cause evacuation problems on the fire floor. An analysis of the benefits and shortcomings of corridor exhaust systems is beyond the scope of this paper.

As stated earlier, the elevator lobbies in this building were separated from the rest of the building by automatic closing doors (see figure 6). The elevators were not intended for building evacuation, but were intended for rescue and fire fighting by the fire department. The smoke control systems were tested to determine the extent to which they provided a pressurized elevator lobby on the fire floor. A pull box on the fifth floor was pulled to activate the smoke control systems⁶.

⁶There is a problem with activating such a smoke control system from a pull box in that the box could be pulled on other than the fire floor.

Differential pressures were measured at a number of locations on the 4th, 5th, and 6th floors. These pressure measurements are listed in table 7. The elevator lobby was positively pressurized with respect to the corridor at a level of 6.2 Pa (0.025 in H₂O) on the fifth floor where the corridor system was exhausting air. On the fourth where there was no corridor exhaust, only slight elevator lobby pressurization of 0.75 Pa (0.003 in H₂O) existed. It can be observed from the data in table 7 that the elevator pressurization system could not maintain positive pressure across any of the elevator doors measured. The pressurization system for stairwell 1 performed slightly better with a positive pressure of 6.2 Pa (0.025 in H₂O) across the stairwell at the fifth floor. This pressure was higher than for the other floors and was due to the corridor exhaust on the fifth floor.

5. DISCUSSION AND CONCLUSIONS

1. The potential problem of elevator door jamming open **was** not observed in any of these tests. However, none of these pressurization levels exceeded 16 Pa (0.065 in H₂O) .
2. Elevator shaft pressurization decreased when an elevator door was opened. In the building 1 elevator, when a ground floor door was open the pressure dropped so low that it could not be measured. In wing C of the building 2 when a ground floor elevator door was open, the elevator pressure dropped from 12 Pa (0.050 in H₂O) to 1.7 Pa (0.007 in H₂O). This decreased pressure reduces the level of smoke protection of the pressurized elevator shaft.
3. The pressure differences produced across elevator shafts B and D of **the** building 2 varied considerably from floor to floor. Apparently these variations were due to variations in the building flow network. Because these pressure variations could result in the failure of a pressurized elevator system, further study of this problem is needed.

4. The pressurized elevator shaft of building **3** was 21 stories tall and the system failed to maintain positive pressurization at the basement and first floor. Pressurization air to this system was supplied by a roof mounted propeller fan which dumped air into the top of the elevator shaft. The failure of the system at the lower floors indicates that there is a limit to how tall an elevator shaft can be successfully pressurized with only a single injection point of supply air. Possibly the concept of multiple injection which is used for pressurized stairwells might be appropriate for elevator shafts. Further study of this problem is needed.
5. The tests on building 4 demonstrated that exhausting the corridor of the fire floor can help maintain a positive pressurization of the elevator lobby and of the stairwell. However, since corridor exhaust can also pull smoke from adjacent spaces into the corridor, the benefits of corridor exhaust need further study.

6. FUTURE DIRECTION

Additional field tests are planned for buildings which have pressurized elevator lobbies. A computer analysis will be performed to investigate the effects of various parameters on the performance of elevator smoke control systems. The computer analysis will utilize a computer program [10] specifically written at NBS for analysis of pressurized stairwells and of pressurized elevator shafts. Ultimately the information gained will be published in a form suitable for use by building system designers .

7. ACKNOWLEDGEMENTS

Thanks are due to the Beachwood Ohio Fire Department and the Detroit Michigan Building and Safety Department for their cooperation. In particular, appreciation is extended to Chief Leonard Billings of

Beachwood, Samuel Schugar of Detroit, and Robert Taylor of Republic Steel Corp. for their aid in locating suitable test buildings and their help during testing. Special appreciation is expressed to William Schmidt of the Veterans Administration and to his son, William Schmidt, Jr., for their considerable help during testing.

8. REFERENCES

- [1] Code for Safety to Life from Fire in Buildings and Structures, NFPA 101-1976, National Fire Protection Association, Inc., Quincy, MA, 1976, pp. 222.

- [2] American National Standard for Elevators, Dumbwaiters, Escalators and Moving Walks, ANSI A17.1, American Society of Mechanical Engineers, New York, 1978.

- [3] ASHRAE Handbook and Product Directory - 1979 Equipment, American Society of Heating, Refrigerating, and Air Conditioning Engineers, New York, NY, 1979.

- [4] Klote, J. H., Stairwell Pressurization, ASHRAE Transactions 1980, Vol. 86, Part 1, American Society of Heating, Refrigerating and Air Conditioning Engineers, New York, NY, 1980.

- [5] DeCicco, P. R., Cresci, R. J., Correale, W. H., Report of Fire Tests, Analysis, and Evaluation of Stair Pressurization and Exhaust in High-Rise Office Buildings, performed for the City of New York by the Polytechnic Institute of Brooklyn, Baywood Publishing Co., New York, NY, Sept. 1972.

- [6] Fung, F. C. W., Evaluation of a Pressurized Stairwell Smoke Control System for a 12 Story Apartment Building, Nat. Bur. Stand. (U.S.), NBSIR 73-277, June 1973.

- [7] Hedsten, G. C., Building and Stair Pressurization System, **ASHRAE Journal**, Vol. 20, No. 7, July 1978, p. 32-35.
- [8] denOuden, L., The Effect of Opening and Closing of Doors on the Pressure Levels in a Building in which the Stairwell is Pressurized, CIB Symposium on the Control of Smoke Movement in Building Fires, Vol. 11, Watford United Kingdom, Nov. 1975, p. 42-49.
- [9] Dias, C., Stairwell Pressurization in a High Rise Building, **ASHRAE Journal**, Vol. 20, No. 7, July 1978, p. 24-26.
- [10] Klote, J. H., A Computer Program for Analysis of Pressurized Stairwells and Pressurized Elevator Shafts, Nat. Bur. Stand. (U.S.), NBSIR 80-2157, January 1981.

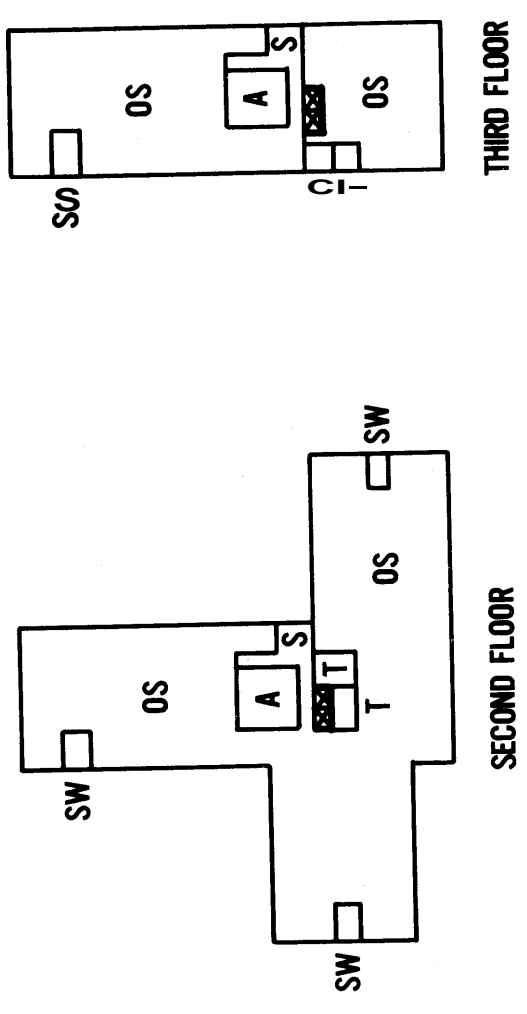
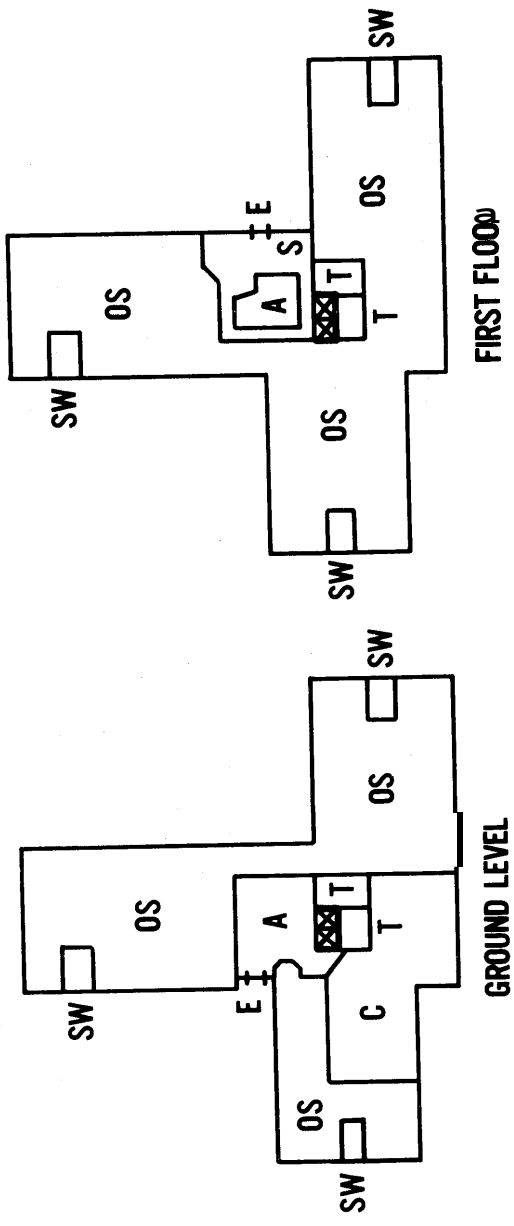

Note: For symbols see Figure 3

Figure 1. Floor Plans for Building 1

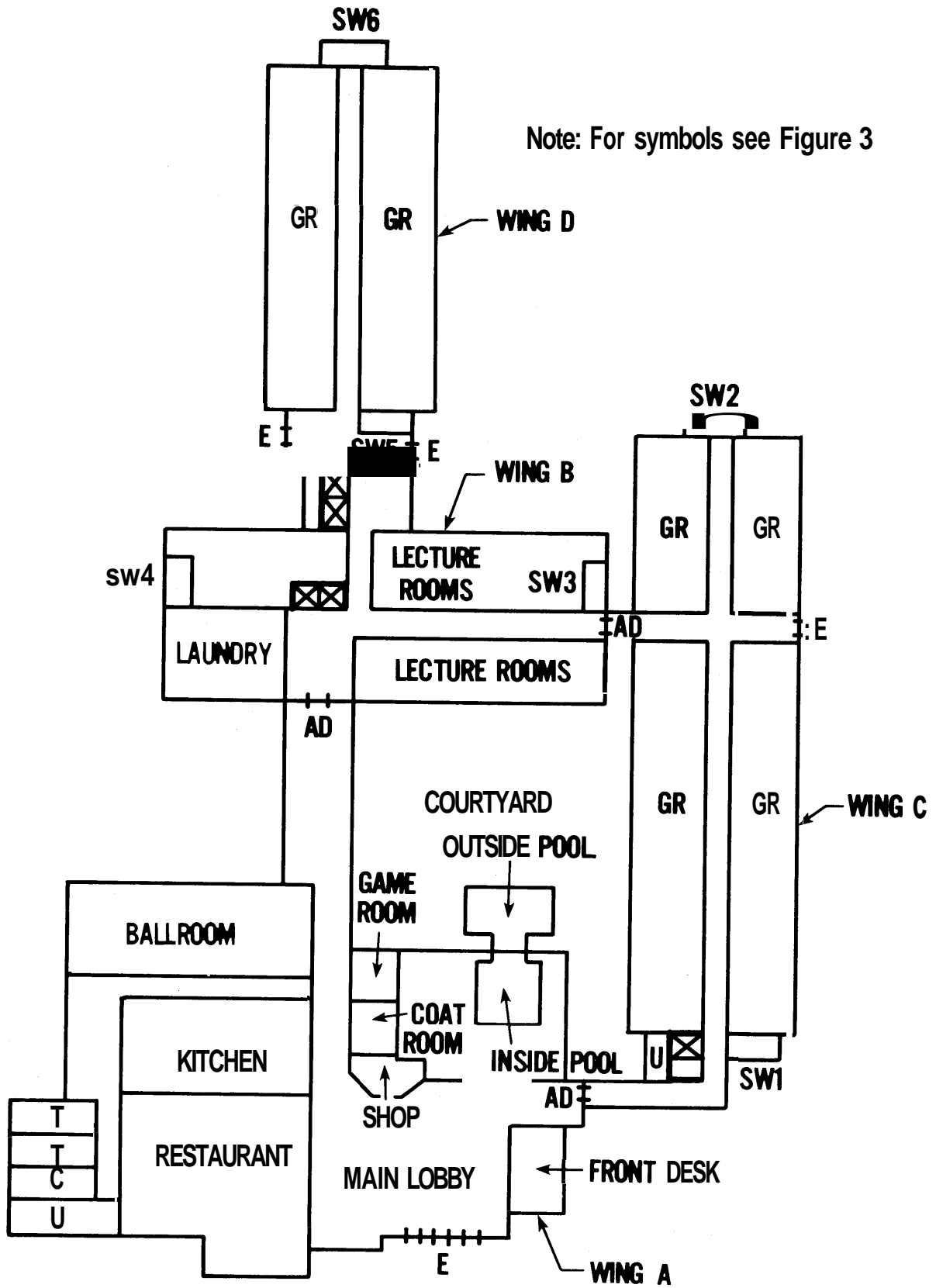

Figure 2. Floor Plan for First Floor for Building 2

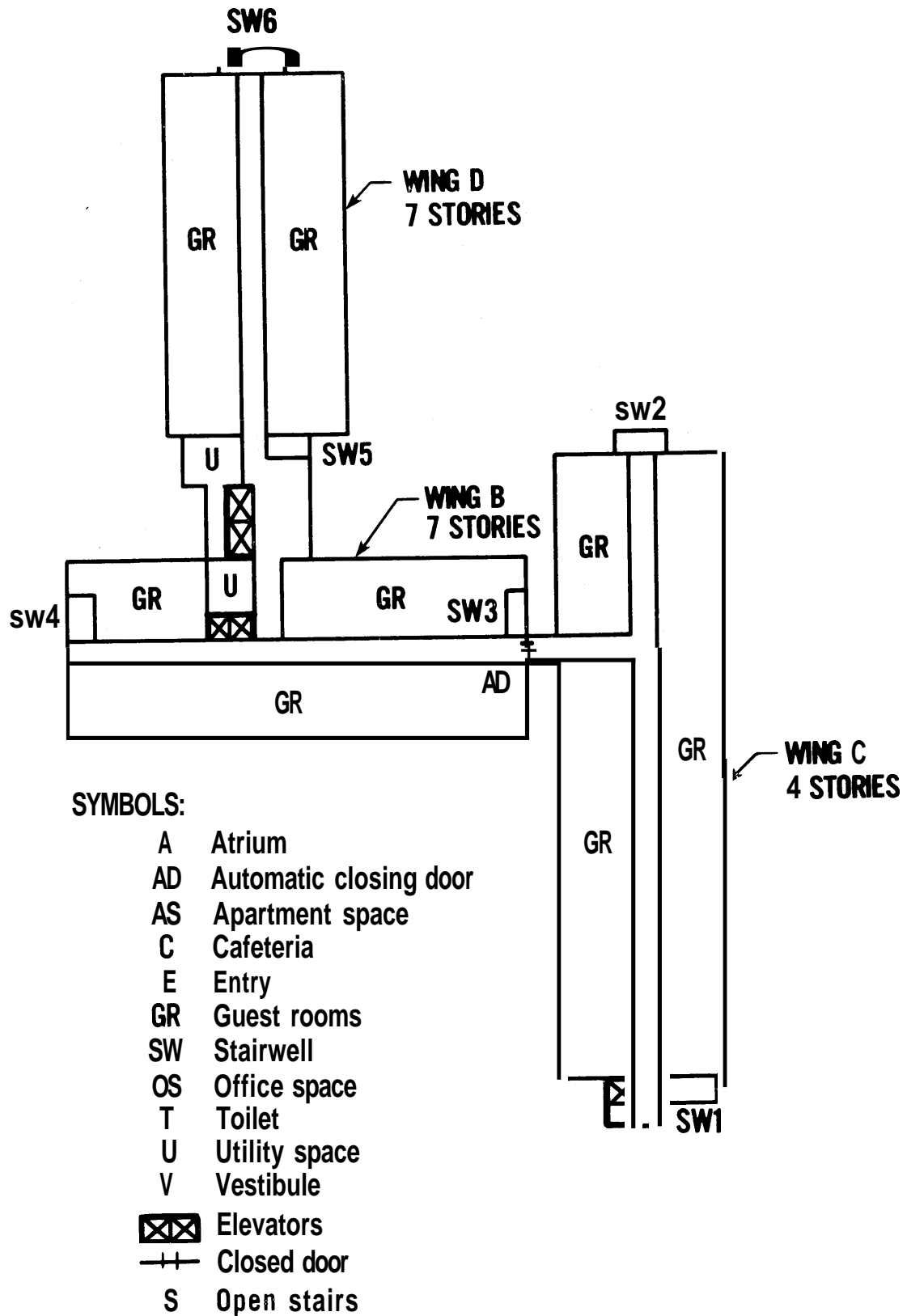
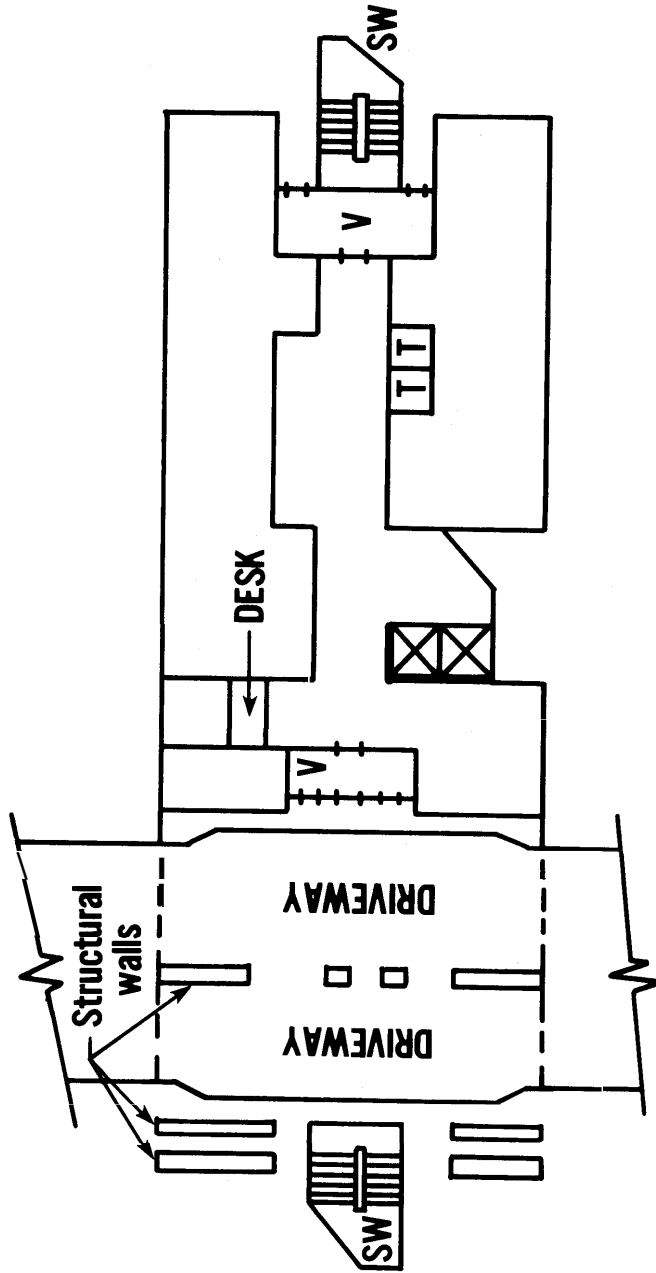
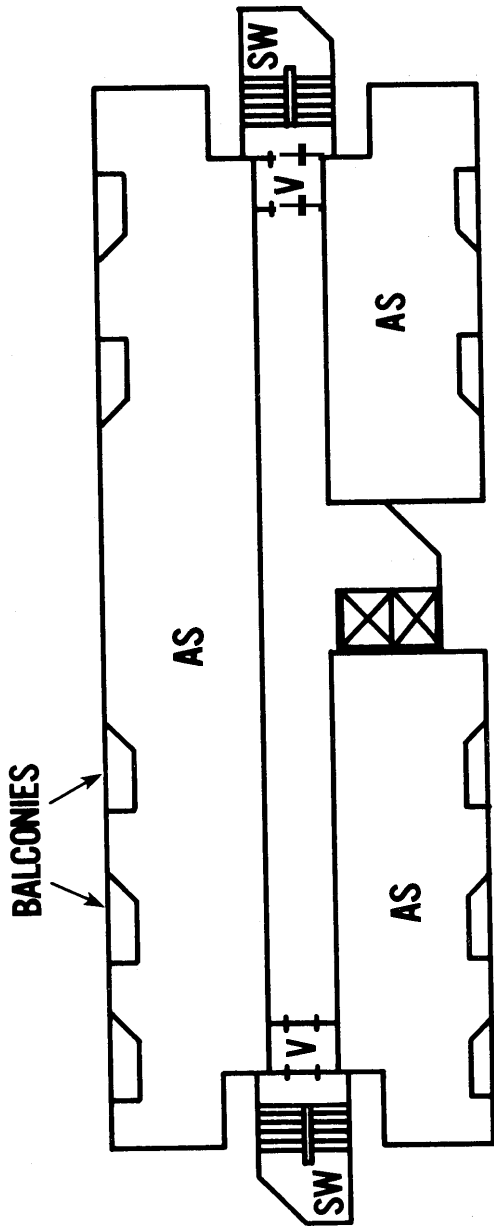

Figure 3. Typical Floor Plan above the First Floor for Building 2



Note: For symbols see Figure 3

Figure 4. First Floor Plan for Building 3



Note: For symbols see Figure 3

Figure 5. Typical Floor Plan above the First Floor for Building 3

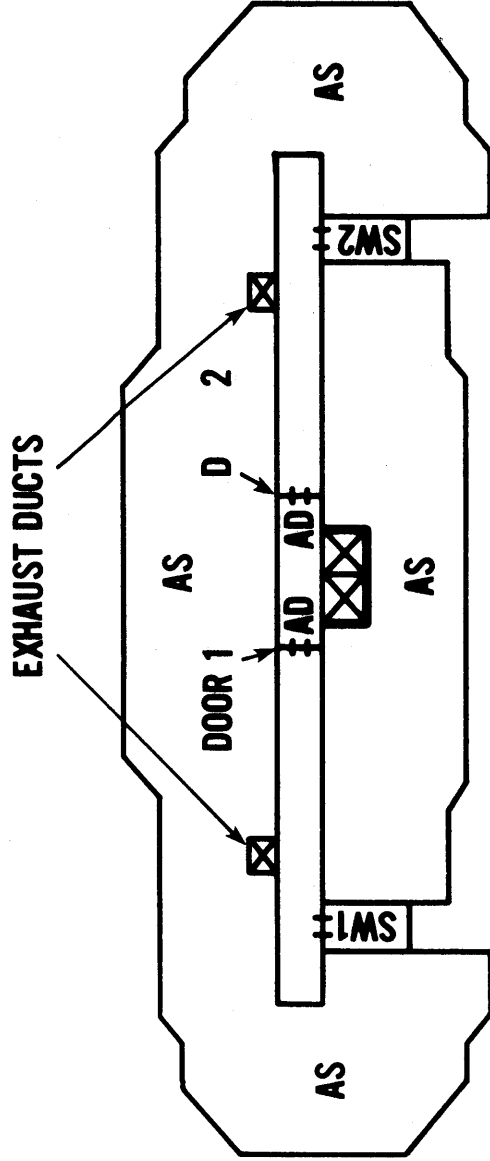

Note: For symbols see Figure 3

Figure 6. Typical Floor Plan for Building 4

Table 1. Pressure Across Elevator Doors of Building 1

Floor	Differential Pressure	
	(Pa)	(in H ₂ O)
3	3.0	0.012
2	3.8	0.015
1	3.8	0.015
Ground	5.0	0.020

Indoor temperature - 24°C (75°F)

Outdoor temperature - 26°C (78°F)

Table 2. Pressures in Wing C of Building 2 with all
Smoke Control Systems Operating

Floor	Elevator		Stairwell 1	
	(Pa)	(in H ₂ O)	(Pa)	(in H ₂ O)
4	16 ^a	0.065 ^a	67	0.27
3	16	0.065	72	0.29
2	12	0.050	62	0.25
1	16 ^b	0.065 ^b	67	0.27

Indoor temperature - 25°C (77°F)
Outdoor temperature - 23°C (74°F)

^aWhen the fourth floor stairwell door was opened the pressure difference across the elevator shaft dropped to 7.5 Pa (0.030 in H₂O).

^bWhen the first floor stairwell door was opened the pressure difference across the elevator shaft dropped to 12 Pa (0.050 in H₂O).

Table 3. Pressures in Wing C of Building 2 with the Corridor Pressurization System Not Operating

Floor	Elevator		Stairwell 1	
	(Pa)	(in H ₂ O)	(Pa)	(in H ₂ O)
4	15	0.060	67	0.27
3	16	0.065	65	0.26
2	14	0.055	72	0.29
1	10	0.040	67	0.27

Indoor temperature - 25°C (77°F)

Outdoor temperature - 23°C (74°F)

Table 4. Pressures in Wing C of Building 2 with
only the Elevator Shaft Pressurization

Floor	Elevator		Stairwell 1	
	(Pa)	(in H ₂ O)	(Pa)	(in H ₂ O)
4	13	0.053	-1.2	-0.005
3	15	0.060	0	0
2	15	0.060	0.25	0.001
1	16	0.065	0	0

Indoor temperature - 25°C (77°F)

Outdoor temperature - 23°C (74°F)

Negative pressures represent air flow from building into the shaft.

Table 5. Pressures in Wings B and D of Building 2

Floor	Elevator		Stairwell 3		Stairwell 4		Stairwell 5		Stairwell 6 ^a			
	B Wing (Pa) (in H ₂ O)	D Wing (Pa) (in H ₂ O)	(Pa) (in H ₂ O)	(Pa) (in H ₂ O)	(Pa) (in H ₂ O)	(Pa) (in H ₂ O)	(Pa) (in H ₂ O)	(Pa) (in H ₂ O)	(Pa) (in H ₂ O)	(Pa) (in H ₂ O)		
7	5.0	0.020	10.0	0.040	37	0.15	37	0.15	75	0.30	25	0.10
6	2.0	0.008	5.0	0.020	30	0.12	37	0.15	72	0.29	25	0.10
5	7.0	0.028	4.5	0.018	-	-	-	-	-	-	-	-
4	6.2	0.025	8.2	0.033	32	0.13	42	0.17	67	0.27	16	0.065
3	8.2	0.033	9.5	0.038	-	-	-	-	-	-	-	-
2	8.7	0.035	11	0.045	35	0.14	42	0.17	75	0.30	14	0.055
1	10	0.040	11	0.043	35	0.14	-	-	7	0.31	-	-
Indoor temperature - 24°C (76°F)												
Outdoor temperature - 24°C (75°F)												

^a Ground floor exterior door of stairwell 6 had no latch and was held open by air pressure

Table 6. Pressures in Building 3

Floor	Elevator Unpressurized		Elevator Pressurized	
	(Pa)	(in H ₂ O)	(Pa)	(in H ₂ O)
21	2.5	0.010	8.7	0.035
20	2.5 ^a	0.010 ^a	7.5	0.030
19	0.75	0.003	6.2 ^b	0.025 ^b
18	1.2 ^a	0.005 ^a	5.5	0.022
17	0.75	0.003	4.0	0.016
16	0.75	0.003	3.2	0.013
15	0.75	0.003	3.0	0.012
14	+0	+0	2.7	0.011
12	+0	+0	2.5	0.010
11	0	0	2.0	0.008
10	1.2	0.005	5.0	0.020
9	0	0	3.0	0.012
8	1.2	0.005	5.0	0.020
7	0	0	1.5	0.006
6	0	0	2.2	0.009
5	-0	-0	1.2	0.005
4	+0	+0	1.2	0.005
3	-0.75	-0.003	3.7	0.015
2	-0	-0	1.2	0.005
1	-8.7 ^c	-0.035 ^c	-4.0 ^d	-0.016 ^d
B	-6.2	-0.025	-2.0	-0.008

Indoor temperature - 25°C (77°F)

Outdoor temperature - 27°C (81°F)

Negative pressures indicate air flow from the building into the shaft.

^aPressure was 8.7 to 10 Pa (0.035 to 0.040 in H₂O) when a direct air connection to the outside existed.

^bPressure was 22 Pa (0.09 in H₂O) when a direct air connection to the outside existed.

^cPressure was 2.5 Pa (0.010 in H₂O) when a ground floor door was open.

^dPressure was 15 Pa (0.060 in H₂O) when a ground floor door was open.

Table 7. Pressures in Building 4

Location	4th Floor		5th Floor ^a		6th Floor	
	(Pa)	(in H ₂ O)	(Pa)	(in H ₂ O)	(Pa)	(in H ₂ O)
Elevator lobby door 1 (lobby pressurized)	0.75	0.003	6.2	0,025	-	-
Elevator door with both lobby doors closed	-2.5	-0.010	-0.75	-0.003	0	0
Stairwell 1 door	0	0	6.2	0.025	1.2	0.005

Indoor temperature - 23°C (73°F)

Outdoor temperature - 24°C (75°F)

^aFire alarm sent from fifth floor so that corridors are exhausted on this floor only.

U.S. DEPT. OF COMM. BIBLIOGRAPHIC DATA SHEET <i>(See instructions)</i>	1. PUBLICATION OR REPORT NO. NBSIR 82-2507	2. Performing Organ, Report No.	3. Publication Date May 1982
4. TITLE AND SUBTITLE ELEVATORS AS A MEANS OF FIRE ESCAPE			
6. PERFORMING ORGANIZATION <i>(If joint or other than NBS, see instructions)</i> NATIONAL BUREAU OF STANDARDS DEPARTMENT OF COMMERCE WASHINGTON, D.C. 20234		7. Contract/Grant No.	8. Type of Report & Period Covered
9. SPONSORING ORGANIZATION NAME AND COMPLETE ADDRESS <i>(Street, City, State, ZIP)</i> Office of Construction Research Veterans Administration Washington, D.C. 20420			
10. SUPPLEMENTARY NOTES <input type="checkbox"/> Document describes a computer program; SF-185, FIPS Software Summary, is attached.			
11. ABSTRACT <i>(A 200-word or less factual summary of most significant information. If document includes a significant bibliography or literature survey, mention it here)</i> <p>This paper is the initial report of an ongoing project at NBS to investigate the use of elevators as a means of fire escape for the handicapped. The use of stairwells for fire evacuation poses a problem for people who cannot use stairs because of physical disabilities. This paper discusses some of the major problems associated with the use of elevators as a means of fire exit and proposes a conceptual solution to those problems. A report is made on field tests of four buildings with elevator protection systems. These protection systems and their interactions with other systems are examined.</p>			
12. KEY WORDS <i>(Six to twelve entries; alphabetical order; capitalize only proper names; and separate key words by semicolons)</i> Building fires; elevators (lifts); egress; evacuation; handicapped; pressurization; smoke control; stairwells.			
13. AVAILABILITY <input checked="" type="checkbox"/> Unlimited <input type="checkbox"/> For Official Distribution. Do Not Release to NTIS <input type="checkbox"/> Order From Superintendent of Documents, U.S. Government Printing Office, Washington, D.C. 20402. <input checked="" type="checkbox"/> Order From National Technical Information Service (NTIS), Springfield, VA. 22161		14. NO. OF PRINTED PAGES 37	15. Price \$7 .50

