

Progress Towards an Absolute Reference for 100 kW Laser Power Measurements

Marla Dowell, Christopher Cromer, Xiaoyu Li, and John Lehman

NIST Quantum Electronics and Photonics Division
M/S 815.01 325 Broadway
Boulder, CO 80305
marla.dowell@nist.gov

With Air Force support, NIST has developed a next generation high power laser radiometer for laser power measurements up to the 100 kW level with lower uncertainties than existing standards. The new radiometer, known as the BB Prime, is capable of measuring 100 kW with very low uncertainty, minimal backscatter and absolute calibration traceable to electrical standards. We will describe the properties and advantages of a relatively new type of electrically calibrated flowing water optical power meter (BB PRIME) which has properties similar to both calorimeter and thermopiles. [1,2] We will detail the construction techniques and estimate the uncertainties for measuring optical power with this radiometer.

The BB Prime is based on the idea of heat balance calorimetry, which relies on measuring the temperature change of cooling water flowing in a closed system that surrounds an optical cavity. Laser light entering the cavity is absorbed and converted to heat, which is transferred to the cooling water. Similarly, for calibration, the optical cavity is replaced with an electrical heater and water flows in a closed system that surrounds the heater. The BBPrime consists of several modular subsystems: a receiver to absorb the incident laser power, two pump modules to supply cooling water to the receiver, a water tank, and an electronic system for data acquisition and control. Each section is separately shippable to the laser site. (See Figure 1.)

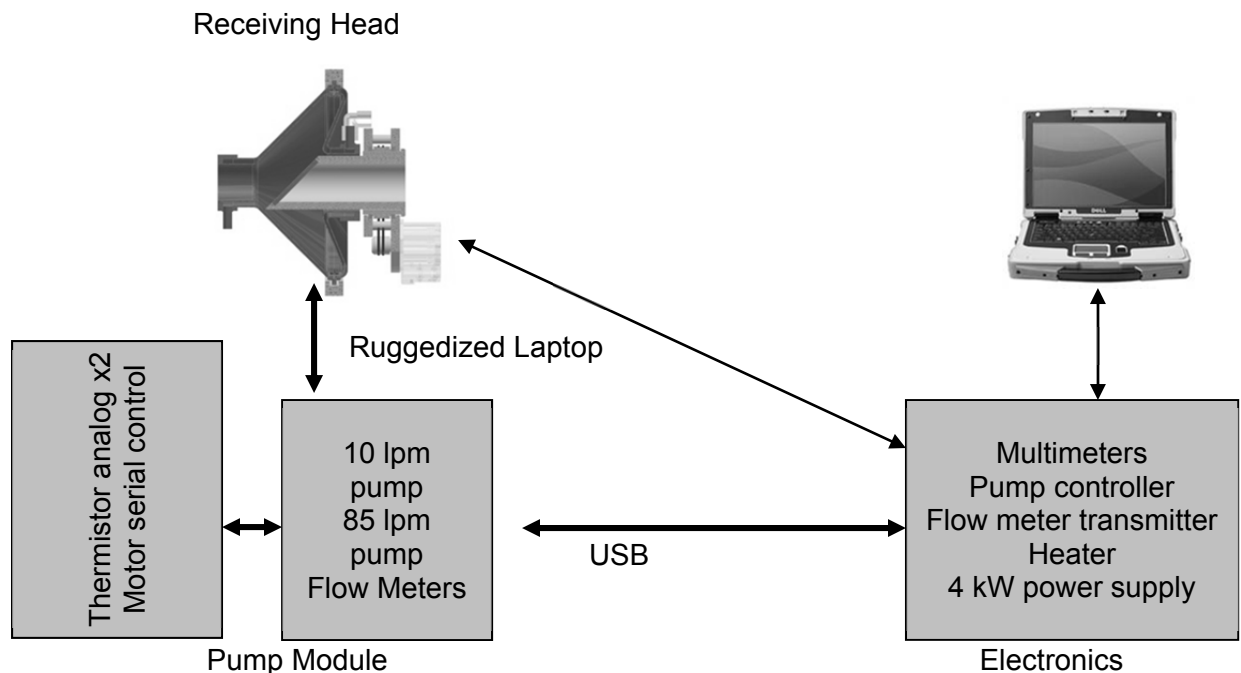

Figure 1. Schematic of the flowing water optical power meter (BB PRIME) system consisting of an optical receiving head, water cooling system (Pump Module), and data acquisition electronics.

HEAT BALANCE CALORIMETRY THEORY

The BB Prime uses an optical absorber to convert optical power into thermal energy which is then cooled by flowing water that is in thermal contact with the absorber. The measured temperature rise of the water is dependent on the heat capacity C_p of water (units of J/g/K). However, since the water is flowing the temperature change ΔT is also dependent on the mass flow rate (g/s) \dot{m} of the water and so represents a measure of thermal power $P_{thermal}$ (W) as illustrated in Equation (1).

$$P_{thermal} = \dot{m} \cdot \Delta T \cdot C_p \quad (1)$$

Water has the second highest specific heat capacity of any known chemical compound (ammonia has the highest). An increase of 1 °C of water temperature at 1 lpm of flow corresponds to ~ 70 W of absorbed power. This property makes it ideal for use in the BB Prime, since the lower the temperature rise of the water for a given power input and flow rate, the lower the uncertainty of the measurement. Another advantage of this technique is that the dynamic range of the radiometer is adjustable by varying the mass flow rate to keep the temperature rise of the water in an optimum range. One might then expect that this type of power meter would be useful for very high power measurements simply by increasing the cooling water flow rate. The BB Prime in this paper is designed to handle up to 100 kW of optical power; this would result in a temperature rise of ~ 15 °C with a water flow rate of 25 gpm.

A basic assumption (common to all optical radiometers) is that in equilibrium and in the absence of parasitic heat paths the measured thermal power gained by the water stream is equal to the optical power absorbed. The equation for measuring the optical power is then:

$$P_{Optical} = B \cdot \dot{m} \cdot (\Delta T_{on} - \Delta T_{off}) \cdot C_p \quad (W), \quad (2)$$

where ΔT_{on} is the temperature difference between the input and the output water with the incident optical power, ΔT_{off} is the baseline temperature difference with no input power, and B is a correction factor that includes optical and thermal losses from the receiver to the environment. The baseline temperature difference is not zero because of heating of the water inside the receiver due to pressure drops and turbulence.

DESIGN

The BB Prime consists of an optical cavity (see Figure 2) and portable, modular components with a framework based on custom shipping containers, which can be set up in less than a day. The BB Prime design has several innovative features – scalable to very high laser powers (from 50 W to 100 kW), novel NIST-developed black coatings with damage thresholds of approximately 15 kW/cm², [3] and a novel water-cooled absorber reducing measurement period by a factor of 100. The details of the black coating are described elsewhere. [2] The optical cavity consists of a rotating mirror to reduce the laser dwell time on the absorbing coating. The mirror is removable and has a high reflectance coating specific to one wavelength (1 or 10 μm) to reduce mirror absorption. The cavity's absorbing surfaces are at an oblique angle to further reduce power density at the coating. Diffuse scatter is minimized by the deep optical cavity. Water flows through a jacket surrounding the optical cavity to measure the absorbed power.

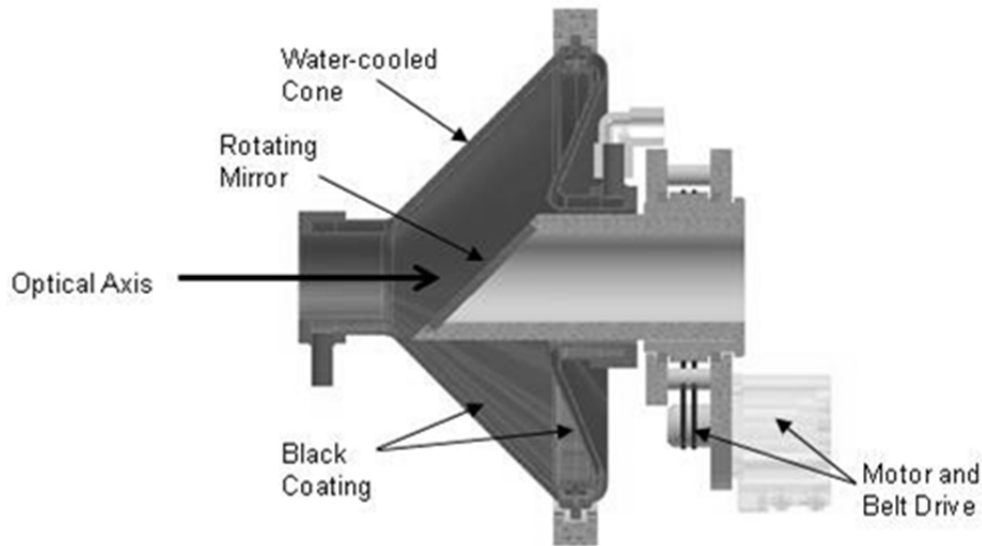

Figure 2. Inside of the optical cavity showing the black coating (left), front view of the BB Prime (center), and portable, modular control equipment (right).

Power Range	50 W to 100 kW
Uncertainty	< 2 %
Maximum Beam Diameter	15 cm
Wavelength Range	1 to 10 μm
Damage Threshold	< 10 kW/cm ²
Maximum On-axis Backscatter (5 mrad)	< 10 ppm
Maximum Thermal Backscatter	< 0.5 %
Maximum Size and Weight (each component)	< 40" x 48"; 300 lbs

Table 1. Expected BB PRIME design goals.

CONCLUSION

We have described a novel electrically calibrated radiometer based on measuring the power in a laser beam with a flowing water optical power meter BB PRIME. By measuring the flow and temperature change of water cooling an absorbing receiver cavity we can accurately measure the optical power from a highly diverging high power diode laser array. The BB PRIME has a dynamic range that is adjustable through changing the water flow rate and the capability to accommodate very large power ranges. We describe the sources of uncertainty with the BB PRIME and show a total expanded uncertainty traceable to SI units of $\pm 0.2\%$ (K=2). The expected design goals are shown in Table 1.

REFERENCES

- [1] "Optical Radiometry," ed. A.C. Parr, R.U. Datta, J.L. Gardner, Elsevier, Amsterdam (2005).
- [2] E.D. West, K.L. Churney, "Theory of isoperibol calorimetry for laser power and energy measurements," *J. Appl. Phys.* 41, 2705-2712 (1970).
- [3] J.H. Lehman, K.E. Hurst, G. Singh, E. Mansfield, J.D. Perkins, and C. Cromer "Core-shell composite of SiCN and multiwalled carbon nanotubes from toluene dispersion," *J Mater Sci* (2010) 45:4251-4254.
- [4] R.L. Smith, T.W. Russell, W.E. Case, and A.L. Rasmussen "A Calorimeter for High-Power CW Lasers," *IEEE Trans Instrum Meas* **IM-21** (1972).

Publication of NIST, an agency of U.S. government, not subject to copyright.