

An iterative algorithm for calculating stylus radius unambiguously

This article has been downloaded from IOPscience. Please scroll down to see the full text article.

2011 J. Phys.: Conf. Ser. 311 012029

(<http://iopscience.iop.org/1742-6596/311/1/012029>)

View [the table of contents for this issue](#), or go to the [journal homepage](#) for more

Download details:

IP Address: 129.6.97.34

The article was downloaded on 24/09/2011 at 15:06

Please note that [terms and conditions apply](#).

An iterative algorithm for calculating stylus radius unambiguously

T V Vorburger, A Zheng, T B Renegar, J-F Song, and L Ma

National Institute of Standards and Technology, 100 Bureau Drive, Gaithersburg, MD 20899, USA

Email: tvtv@nist.gov

Abstract. The stylus radius is an important specification for stylus instruments and is commonly provided by instrument manufacturers. However, it is difficult to measure the stylus radius unambiguously. Accurate profiles of the stylus tip may be obtained by profiling over an object sharper than itself, such as a razor blade. However, the stylus profile thus obtained is a partial arc, and unless the shape of the stylus tip is a perfect sphere or circle, the effective value of the radius depends on the length of the tip profile over which the radius is determined. We have developed an iterative, least squares algorithm aimed to determine the effective least squares stylus radius unambiguously. So far, the algorithm converges to reasonable results for the least squares stylus radius. We suggest that the algorithm be considered for adoption in documentary standards describing the properties of stylus instruments.

1. Introduction

In stylus measurements of surface roughness, the finest topographic details that can be measured on the surface depend on the shape and size of the stylus tip. Hence, the stylus radius is an important specification for stylus instruments. Recommended values of stylus radius are given in national and international documentary standards and values are commonly provided by instrument manufacturers. However, it is difficult for users or manufacturers to measure the stylus radius unambiguously. Accurate profiles of the stylus tip may be obtained by profiling over an object sharper than itself, such as a razor blade [1-5] (see figure 1), or by scanning electron microscopy (SEM) or by optical microscopy for large tips. However, the stylus profile thus obtained is a partial arc, spanning in most cases $\pm 45^\circ$, and unless the shape of the tip is a perfect sphere or circle, the effective value of the radius depends on the length of the tip profile over which the radius is determined.

We have developed an iterative, least squares algorithm aimed to determine the effective stylus radius unambiguously. The procedure starts with an initial estimate of the radius, such as with a specification provided by the manufacturer, and performs a least squares fit over a profile length consistent with the manufacturer's specification. If a different least squares radius is obtained, then a new profile-length parameter is calculated and the least squares procedure is applied again until convergence is reached. We have tested the algorithm so far with vertical least squares circle fits of measured stylus profiles, which tend to be flatter on top than near the flanks. So far, the algorithm converges to reasonable results for the least squares stylus radius. We suggest that the algorithm be considered for adoption in documentary standards describing the properties of stylus instruments.

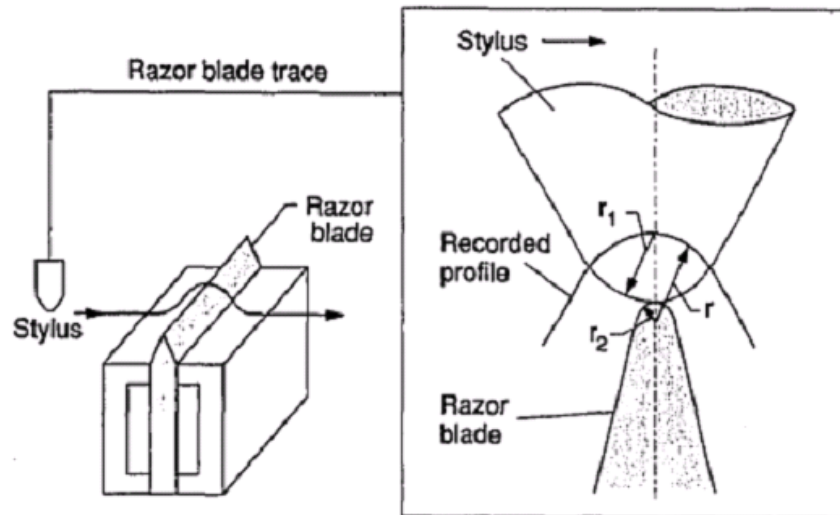

Figure 1. Schematic diagram of the razor blade trace method for profiling a stylus tip [2,4,5].

1.1. Background

Determining the effective least squares radius of a stylus tip involves two steps: measuring the stylus tip profile accurately and extracting an effective radius from the measured tip profile. There are several ways to measure stylus tip profiles with sufficient accuracy [1]: SEM, optical microscopy or optical projection, and scanning the stylus tip over a sharp object such as a razor blade [1-5]. SEM has high resolution and is certainly useful for stylus tips with radii as small as several nanometers. Optical microscopy and optical projection have lower resolution but are useful for determination of stylus radii of about $10\ \mu\text{m}$ and perhaps somewhat smaller. The razor blade approach has been written into documentary standards [4,5] and has been shown to be useful for profiling stylus tips with radii as small as about $0.1\ \mu\text{m}$ [2] or as large as about $12\ \mu\text{m}$ [1].

Once the profile has been measured, the second step of determining the effective radius from a measured stylus tip profile is prone to ambiguity. Due to imperfections in the shape of the stylus tip profile, the computed value of the radius depends on the length of arc or area of tip surface over which the radius is calculated. Further, for any measurement application on real engineering surfaces the effect of the stylus radius depends on the area of contact between the tip of the stylus and the surface and hence on the local topography of the surface. The functional stylus radius, which is related to the outside envelope of the stylus with the contacted surface, is therefore, dependent on the particular application. For the present paper, we ignore the latter problem and confine ourselves to determining the radius of the stylus unambiguously in a standard way.

1.2. Focus

We also limit our focus in other ways. The aim is to enable vendors and users of stylus instruments for surface profiling to agree on a quantitative measure of the quality of a stylus tip, independent of any particular application. First, for simplicity, we limit ourselves to 2D profiling and the determination of an effective circular radius because the results are simpler to describe and visualize. However, the method can be extended to 3D topography measurements and to determining effective spherical radius from 3D data. Second, we limit the discussion to standard least squares fitting of the stylus tip profile to the parameters of a circle. Whereas from a functional point of view, it would be preferable to construct an effective stylus profile based on its points of contact rather than its mean profile, this brings us back to issues regarding the shape of the measured surface and to specific applications. Third, for simplicity, we limit the least squares fitting process here to minimizing the residuals in the vertical direction rather than the radial direction.



Figure 2. Razor blade profile of a stylus that was in use for many years in our laboratory. The stylus was chisel shaped with a flat about $4 \mu\text{m}$ across at the tip [1].

Even with this narrow focus, the least squares fitting of the partial arc of a stylus tip profile is ambiguous because the fitted radius depends on the length of profile used for the fitting process, unless the measured tip profile is perfectly round. We illustrate the issue with the profile of a fine stylus used for a number of years in our laboratory. This stylus (figure 2) has a flat across the tip about $4 \mu\text{m}$ long. It is certainly useful for probing peak or valley surface features more than $4 \mu\text{m}$ across but is virtually useless for discerning features less than about $4 \mu\text{m}$ across. How does one determine the effective radius of the stylus from a profile of its projected shape? The issue may be highlighted more starkly by considering the extreme case of a simulated, perfectly flat tip shown later on the left hand side of figure 4. The effective radius is infinite for closely spaced features but is approximately $4 \mu\text{m}$ for features that are spaced more widely than, say, $5 \mu\text{m}$. Accordingly, a least squares fit of the central $4 \mu\text{m}$ of the tip profile or smaller should yield an effective radius of infinity, but a fit of length $5 \mu\text{m}$ yields a finite radius.

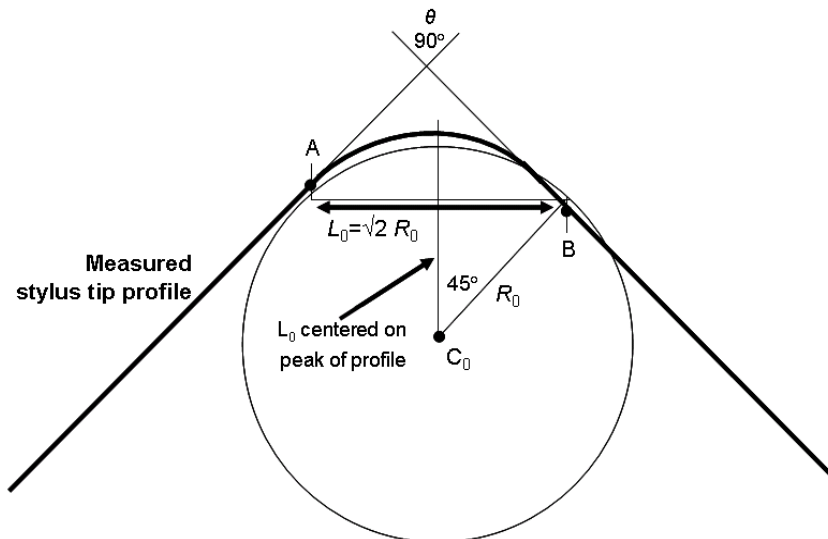

Figure 3. Construction of the parameters of a circle for the first iteration of the least squares fitting routine to determine the radius of the stylus tip from its measured profile. The initial guess for the radius is R_0 ; the chord length L_0 is $(\sqrt{2}) R_0$ for a tip with 90° apex angle. This chord length defines the profile to be fitted and is centered about the highest point on the profile. The center of this initial circle is C_0 , and A and B represent the extremes of the measured profile to be fitted initially.

2. Stylus Tip Fitting Algorithm

The algorithm is an iterative least squares fitting process that works as follows:

- The profile of the stylus tip is measured by one of the methods described above.
- An estimate (R_0) is made of the stylus tip radius, based on the manufacturer's specification or on a known value from a previous measurement.
- The cone apex angle θ is calculated from the straight shanks of the measured stylus profile or is known beforehand.
- Using the values of R_0 and θ , the horizontal chord length (L_0) of the ideal circular stylus tip profile is calculated, that is, the horizontal distance between the transition points where the circular profile would meet a straight shank with apex angle θ . For a stylus tip with a 90° apex angle, L_0 is equal to $(\sqrt{2})R_0$. This is illustrated in figure 3. For arbitrary θ and R_0 , the formula is

$$L_0 = 2 R_0 \sin(90^\circ - \theta/2) \quad (1)$$

- The length L_0 serves as the horizontal length of the stylus tip profile to be fitted. This chord length is then centered on the highest point in the measured stylus tip profile and a least squares fit of the associated segment of profile is performed to the parameters of a circle. The fitted segment of profile may include portions of the shank as shown here by the profile portion near B in figure 3.
- The parameters of the fitted circle then determine new values for the radius R_1 and center of the circular profile (x_1, y_1). The fitted radius R_1 is used to calculate a new segment L_1 , now given by $2 R_1 \sin(90^\circ - \theta/2)$, which is centered on the x-coordinate (x_1) of the fitted circle and a new least squares fit is performed.
- The values of R, L , and x are iterated until the calculation converges to a point where the successive values for R are sufficiently close together. Our current criterion is a difference of $0.01 \mu\text{m}$.
- A damping fraction for the changes in R, L , and/or x can be chosen so that the calculation does not become unstable. That is, the full correction resulting from each least squares fit is not applied with each iteration but only a fraction of it.

3. Results

Results are given for two cases: the simulated flat tip stylus and the measured tip profile of a stylus currently used in our laboratory for calibrations. The left hand side of figure 4 shows the results for the flat tip having a width $4 \mu\text{m}$ across. The apex angle is 90° . A slight tilt was applied to this profile so that the highest point of the profile was at the right hand corner of the chisel shape. Thus the fitted circles were made to start well off center. Nevertheless, the routine converged in approximately five iterations to a result for R of $4.7149 \mu\text{m}$ from a starting estimated value of $5 \mu\text{m}$. From a different starting value of $2 \mu\text{m}$, the routine converged in about eight iterations to the same final value of $4.7149 \mu\text{m}$ for R .

The right hand side of Fig. 4 depicts a razor blade profile for a stylus tip currently used in our laboratory. The stylus has a nominal apex angle of 90° and a nominal radius of $2 \mu\text{m}$. The least squares fitting routine converges in about seven iterations to a radius of $1.4455 \mu\text{m}$. This type of result, where the fitted radius is smaller than the nominal radius assigned by the manufacturer, is consistent with other results we have obtained for similar types of tips. The combined standard uncertainty that we estimate for the above result is $0.11 \mu\text{m}$. It depends on the Type A repeatability, the uncertainty of the x - and z - magnification, the size of the razor blade tip, which is about 30 nm , and on a model we use to estimate the effective radius for different types of surfaces, where we calculate the least squares radius for a length of tip profile extending over $\pm 15^\circ$.

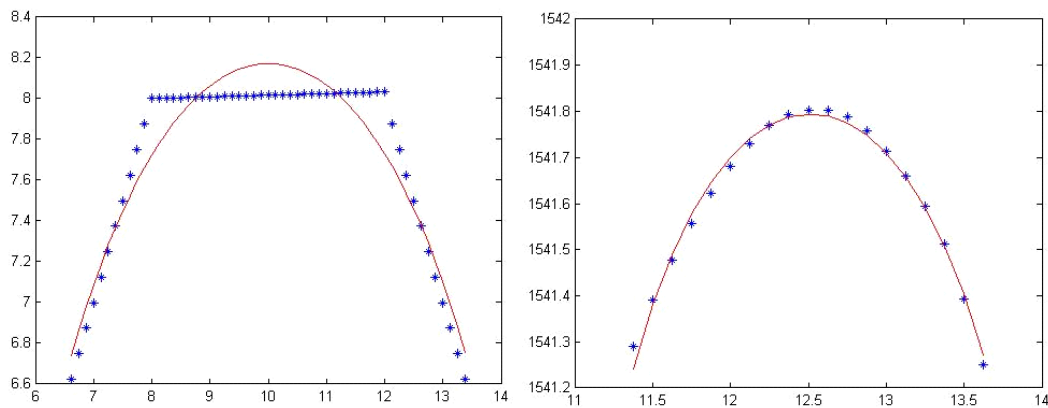

Figure 4. All units are in μm . (Left) data points simulating a stylus tip profile with a flat $4\ \mu\text{m}$ across and curve showing the least squares fitted profile resulting from the fitting algorithm discussed here; the fitted radius is $4.7149\ \mu\text{m}$. (Right) measured razor blade profile (data points) of a stylus tip with a nominal radius of $2\ \mu\text{m}$ and the resulting fitted profile; the fitted radius is $1.4455\ \mu\text{m}$. Note that the aspect ratios of the graphs are not one-to-one. The standard uncertainties of individual data points in the right hand profile are approximately $1\ \text{nm}$ in the vertical direction and $0.02\ \mu\text{m}$ in the horizontal direction.

4. Discussion

The goal of this procedure is not to determine the effective radius of a stylus tip for profiling surfaces with any surface application in mind; the number of applications of surface finish measurement is too large for us to be able to provide a procedure that is optimally suitable for all users. Rather, the goal is to provide a common, unambiguous approach to calculate stylus radius from a partial arc of say, 90° or 120° , that vendors and users can agree to. The procedure could then be designated in documentary standards. If required, standards could further designate acceptable deviations of the stylus tip profile from the fitted radius. Currently, the International Organization for Standardization (ISO) standards for surface texture measurement do not provide a procedure to calculate stylus radius, and the related U.S. standard, American Society of Mechanical Engineers (ASME) B46.1–2009, contains a definition based on geometrical construction that is difficult to use to obtain an unambiguous result. A number of simplifications in the procedure implemented here were described in Sec. 1, but the procedure can be adapted to more realistic cases.

References

- [1] Vorburger TV, Teague EC, Scire FE and Rosberry FW 1979 Measurements of stylus radii, *Wear* **57** 39-49.
- [2] Song JF and Vorburger TV 1991 Stylus profiling at high resolution and low force *Appl. Opt.* **30** 42-50.
- [3] Song JF and Vorburger TV 1997 Measurement comparison of stylus radii, in *Proc. 1997 Intl. Conf. Prec. Engr.* (ICPE 97, Taipei) **2** 823-828.
- [4] ASME B46.1–2009 2010 *Surface Texture (Surface Roughness, Waviness, and Lay)*, American Society of Mechanical Engineers, New York).
- [5] ISO 5436-2: 2000 *Geometrical Product Specifications (GPS) — Surface texture: Profile method; Measurement standards — Part 1: Material measures* (International Organization for Standardization, Geneva).