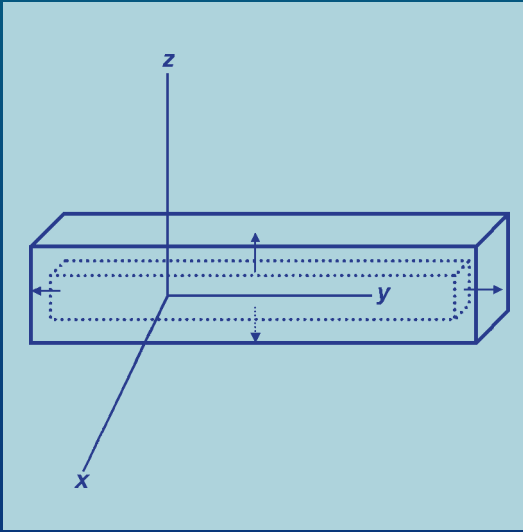


# Capacitance Cell Measurement of the Out-of-Plane Expansion of Thin Films

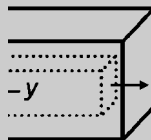


Chad R. Snyder  
Frederick I. Mopsik

**NIST**  
National Institute of  
Standards and Technology  
Technology Administration  
U.S. Department of Commerce

Special  
Publication  
960-7





Special Publication 960-7

# Capacitance Cell Measurement of the Out-of-Plane Expansion of Thin Films

Chad R. Snyder  
Frederick I. Mopsik

Materials Science and  
Engineering Laboratory

November 2001



**U.S. Department of Commerce**

Donald L. Evans, Secretary

**Technology Administration**

Phillip J. Bond, Under Secretary for Technology

**National Institute of Standards and Technology**

Arden L. Bement, Jr., Director

Certain commercial entities, equipment, or materials may be identified in this document in order to describe an experimental procedure or concept adequately. Such identification is not intended to imply recommendation or endorsement by the National Institute of Standards and Technology, nor is it intended to imply that the entities, materials, or equipment are necessarily the best available for the purpose.

---

National Institute of Standards and Technology  
Special Publication 960-7  
Natl. Inst. Stand. Technol.  
Spec. Publ. 960-7  
44 pages (November 2001)  
CODEN: NSPUE2

U.S. GOVERNMENT PRINTING OFFICE  
WASHINGTON: 2003

For sale by the Superintendent of Documents  
U.S. Government Printing Office  
Internet: [bookstore.gpo.gov](http://bookstore.gpo.gov) Phone: (202) 512-1800 Fax: (202) 512-2250  
Mail: Stop SSOP, Washington, DC 20402-0001

## FOREWORD

The coefficient of thermal expansion (CTE) continues to be a critical parameter in modeling for the microelectronics industry. Over the past several years, NIST has worked to develop a robust and highly-accurate means for determining the CTE of films with thicknesses ranging from 2  $\mu\text{m}$  up to 1 cm. To make this metrology accessible to a wider community and to help users to adhere to “good practice” procedures when using this metrology, this Guide was created. At the end of this Guide, the data reduction technique necessary for using this metrology for the determination of hygrothermal expansion is discussed, and a detailed look at the uncertainties associated with this metrology is provided.

More information on the SP 960 series can be found on the Internet at <http://www.nist.gov/practiceguides>. This website includes a complete list of NIST Practice Guides and ordering information.



## **ACKNOWLEDGMENTS**

The authors would like to thank the NIST Office of Microelectronics Programs for financial support in the development of this metrology.





**TABLE OF CONTENTS**

<i>List of Figures</i> .....	<i>ix</i>
<b>1. Introduction</b> .....	<b>1</b>
<b>2. Scope</b> .....	<b>3</b>
<b>3. Test Specimens</b> .....	<b>4</b>
3.1 Size .....	4
3.2 Condition .....	4
3.3 Preparation .....	4
<b>4. Apparatus</b> .....	<b>5</b>
4.1 Instrumentation .....	5
4.2 Capacitance Cell .....	6
4.2.1 Electrode Construction .....	6
4.2.2 Holder Construction .....	9
4.2.3 Cell Assembly .....	9
4.3 Accessories .....	14
4.3.1 Coaxial Cable .....	14
<b>5. Procedure</b> .....	<b>17</b>
5.0a Thermal Expansion .....	17
5.0b Hygrothermal Expansion .....	18
5.1 Calibration .....	18
5.2 Test Measurements .....	20
5.3 Evaluation .....	20
5.4 Calculation of Coefficient of Thermal Expansion .....	22
5.5 Report of CTE Data .....	22
5.6 Plot of CTE Data .....	23

## ◆ Capacitance Cell Measurement

<b>6. Notes .....</b>	<b>24</b>
6.4    “Debugging” a Reproducibility Problem .....	24
<b>APPENDIX A — Dielectric Constant of Air .....</b>	<b>25</b>
<b>APPENDIX B — Discussion of Uncertainties .....</b>	<b>27</b>
B.1. <i>Electrode Tilt</i> .....	27
B.2. <i>Temperature and Pressure Uncertainties</i> .....	27
B.3. <i>Thickness Dependence of the Effective Area</i> .....	28
B.4. <i>Other Sources of Uncertainty with Respect to             Thickness Reproducibility</i> .....	29
B.5. <i>Capacitance Bridge Calibration</i> .....	30
<b>References .....</b>	<b>31</b>

**List of Figures**

Figure 1. Fused quartz blank electrode construction. Note that the drawing is not to scale; the supplied measurements should be used. (The diameter of the blank is 10 cm as specified in the text.) .....	7
Figure 2. Electrode construction showing the nichrome coating, placement of the copper wires, conducting paint, and one of the three screw clamp holes. Note that the drawing is not to scale; the supplied measurements should be used .....	8
Figure 3. Cross-sectional view of the dimensions for construction of the electrode holder. The materials for the cell holder are brass or copper. Note that the drawing is not to scale; the supplied measurements should be used .....	10
Figure 4. Top and bottom views of the electrode holder. The materials for the cell holder are brass or copper. Note that the drawing is not to scale; the supplied measurements should be used .....	11
Figure 5. Side and bottom views of the dimensions for construction of the electrode holder's bottom cover plate. Note that the drawing is not to scale; the supplied measurements should be used .....	12
Figure 6. Side and bottom views of the dimensions for construction of the aluminum shield plate. Note that the drawing is not to scale; the supplied measurements should be used .....	13
Figure 7. Schematic of electrical connections to bottom electrode .....	15
Figure 8. Diagram of assembled capacitance cell .....	16
Figure 9. Typical thickness versus time plot for a material that undergoes dimensional contraction (creep) under load after a temperature step. (This plot is given to aid the reader only; it should not be interpreted as actual data.) .....	21

## ◆ Capacitance Cell Measurement

Figure 10. Typical thickness versus time plot for a material that does not undergo dimensional contraction (creep) under load after a temperature step. (The plot is given to aid the reader only; it should not be interpreted as actual data.) ..... 21

Figure 11. Typical relative expansion curve. (The plot is given to aid the reader only; it should not be interpreted as actual data.) ..... 23

## 1. INTRODUCTION

The coefficient of thermal expansion (CTE) is one of the key design parameters in the microelectronics industry. CTE mismatch between different materials is a prime concern to this industry since thermal stresses can build up as a result and lead to device failure. To minimize the chance of such failure, it is vitally important that reliable values for the CTE of the materials be known so that modeling can be performed to assist design of the structure. CTE values for these materials are often obtained from measurements performed on large (thick) samples because of the limitations in sensitivity of most commercial devices. As a result, most standard test methods require samples thicker than 1 mm.<sup>[1,2]</sup> Unfortunately, many of these materials can be formed only as thin layers, and there is some question in the literature regarding the thickness dependence of the CTE.<sup>[3–5]</sup>

To improve upon this situation, a metrology to obtain CTE values was developed that was based on capacitance measurements — with a resulting wide range of measurable thickness and a high sensitivity. (Throughout this guide, this metrology will be referred to as a “capacitance cell.”) The capacitance-based technique was chosen since commercial capacitance bridges exist that can measure capacitance to a relative standard uncertainty of better than  $10^{-6}$  pF/pF. With proper design of the measurement cell, the relative uncertainty in thickness can approach the relative uncertainty in capacitance. Many researchers have recognized this fact and a large number of different designs have been proposed.<sup>[6–9]</sup> The uniqueness of the metrology in this guide relative to the previous capacitance-based metrologies lies in the fact that the measurement of expansion is completely independent of the dielectric properties of the material of interest, i.e., the sample lies outside of the measurement path.

Three papers have been published on our capacitance cell which attempted to make the metrology as broadly applicable as possible. The first paper described the use of the cell for CTE measurements of insulating materials.<sup>[10]</sup> The second paper expanded the use of the capacitance cell to hygrothermal expansion of insulating materials.<sup>[11]</sup> The third, and final, paper extended the capability of the cell to measure insulating, semiconducting, and conducting samples.<sup>[12]</sup> This recommended practice guide expands upon the results presented in those three papers and gives specific construction and assembly guidelines and discusses the format in which the resulting data should be presented.

While in the broadest sense this recommended practice guide describes measurement of “hygrothermal expansion,” the main focus of this guide is the determination of the coefficient of *thermal expansion* of thin film materials.

## ◆ Capacitance Cell Measurement

Since hygrothermal expansion is a multivariate function, the reference state and the resultant relative expansion are not easily (or uniformly) defined.

Data can be examined that have been measured at:

- constant temperature and variable humidity;
- variable temperature and constant relative humidity;
- variable temperature and constant partial pressure of water vapor; or
- variable temperature and humidity.

No coefficient of hygrothermal expansion is easily defined. This difficulty is compounded by the fact that relative humidity history is typically more important than thermal history, as demonstrated in Ref. [11]. For these reasons, while the necessary computation scheme will be presented for determining the thickness under hygrothermal expansion, no discussion of how the data should be presented will appear in this guide.

## 2. Scope

This metrology is designed primarily for obtaining the z-axis expansion of materials, with thicknesses between 2  $\mu\text{m}$  and 1 cm, such as those typically used in High Density Interconnect Structures (HDIS) and microvias by the use of a capacitance-based measurement technique. The expansion of these materials can be due to changes in temperature (i.e., thermal expansion), moisture (i.e., swelling), or any combination of these two (i.e., hygrothermal expansion).

### **3. Test Specimens**

#### **3.1 Size**

Specimens shall have thicknesses between 2  $\mu\text{m}$  and 1 cm and have in-plane dimensions of approximately 1 cm x 1 cm and be as close to a perfect square as possible. Three such specimens are needed for each test.

#### **3.2 Condition**

All specimens should be free from dust and as uniform as possible.

#### **3.3 Preparation**

All specimens should be fully cured according to manufacturer's recommendations.



## 4. Apparatus

### 4.1 Instrumentation

**4.1.1** A precision automated three-terminal capacitance bridge which uses an oven-stabilized quartz capacitor and has a cited guaranteed relative resolution of better than  $5 \times 10^{-7}$  pF/pF for a range of capacitances of 0.625 pF to 1250 pF (equivalent to Andeen–Hagerleen 2500A 1 kHz Ultra-Precision Capacitance Bridge<sup>1</sup>).

#### 4.1.2a Thermal Expansion Measurements

An oven capable of maintaining the temperature(s) of interest to  $\pm 0.1^\circ\text{C}$  with a feed-through hole for the coaxial cable and equipped with a dry air (not nitrogen gas) purge (dew point of less than  $-70^\circ\text{C}$ ).<sup>2</sup>

#### 4.1.2b Hygrothermal Expansion Measurements

An environmental chamber capable of maintaining the temperature(s) of interest to  $\pm 0.5^\circ\text{C}$  and the relative humidities of interest to  $\pm 0.5\%$ .

**4.1.3** Pressure sensor (or barometer) capable of measuring atmospheric pressure to within 13 Pa (0.1 mm of Hg).

**4.1.4** Vacuum pump and vacuum oven with an interior large enough for the assembled capacitance cell.

**4.1.5** Laminar flow hood equipped with a high efficiency particle arresting (HEPA) filter, or ISO Class 6 cleanroom.

**4.1.6** Analytical balance capable of determining the mass of the top electrode to  $\pm 1$  g.

---

<sup>1</sup> Certain commercial materials and equipment are identified in this guide in order to specify adequately the experimental procedure. In no case does such identification imply recommendation or endorsement by the National Institute of Standards and Technology, nor does it imply that the items identified are necessarily the best available for the purpose.

<sup>2</sup> All cited uncertainties in this document are the best estimate of two standard deviations in the experimental uncertainty.

## ◆ Capacitance Cell Measurement

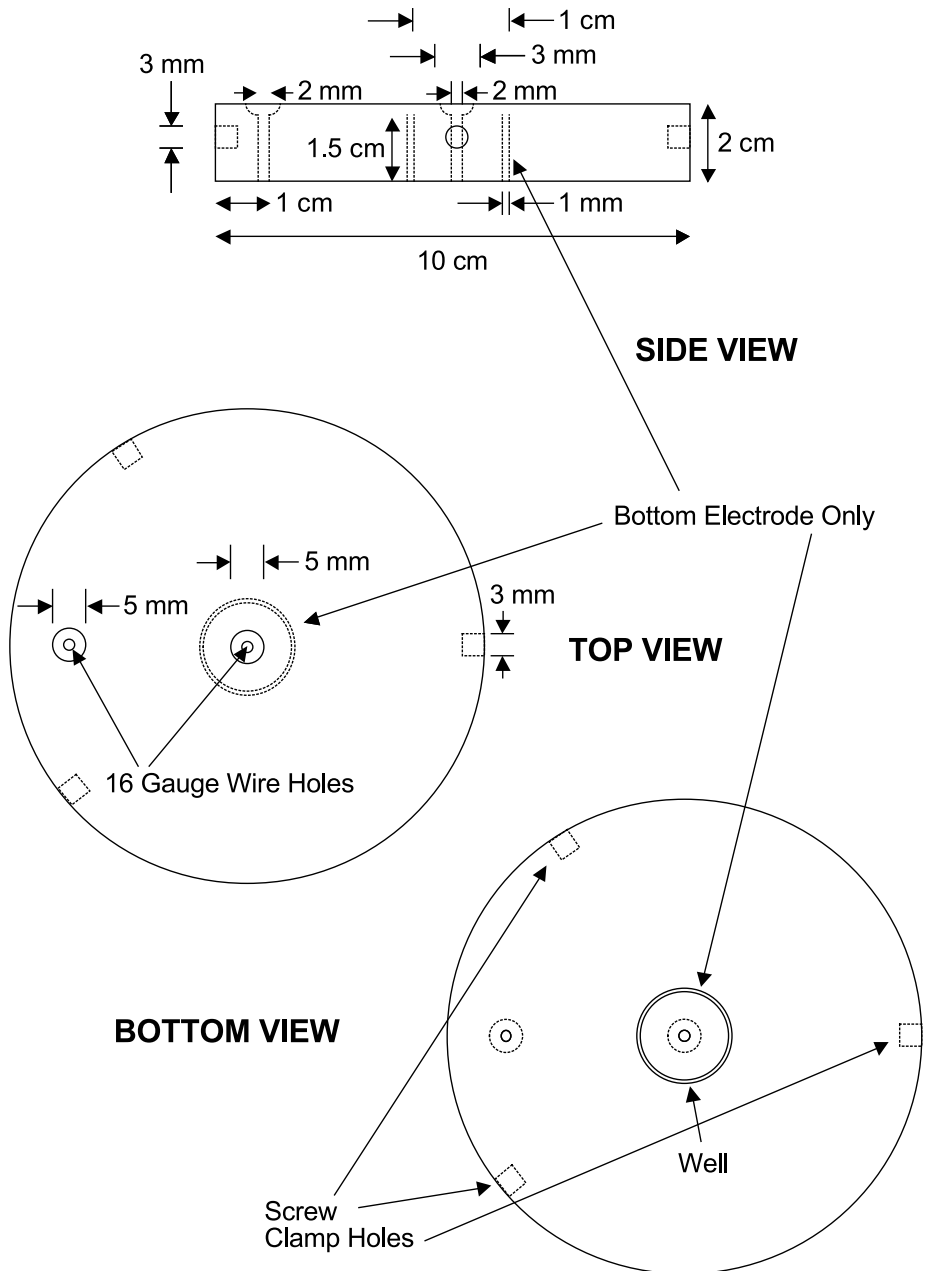
- 4.1.7** A caliper capable of measuring an approximately 2 mm-thick bar to  $\pm 0.1$  mm.
- 4.1.8** (Optional) A computer capable of interfacing with the oven, the pressure sensor, and the capacitance bridge to automate the measurements.

## 4.2 Capacitance Cell

### 4.2.1 Electrode Construction

The electrodes are constructed in the following manner: two 10 cm-diameter fused-quartz blanks are ground and polished to optical flatness. On one side (the back) of one blank, which will be the bottom electrode, a thin (0.1 mm) groove 1 cm in diameter and extending to within 5 mm of the front surface is cut in the center of the blank. The circumference of the bottom electrode has three small indentations drilled so that set screws in the holder can be inserted into them without any applied force (see Figure 1). In the center of both blanks, 2 mm diameter holes are drilled through from the back surface to the front surface. On the front side of both blanks, 3 mm diameter hemispherical indentations are made into the surface of the blanks centered on the drilled holes. (The dimensions for all of the above aspects of the electrode construction are shown in Figure 1.)

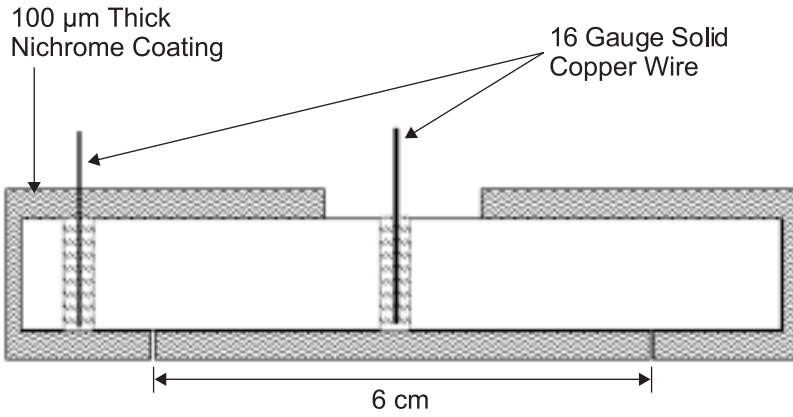
Ball bearings (3 mm in diameter) are placed into the hemispherical indentations on the front surface of the blanks and the blanks are inverted. Into each of the holes that were capped with the bearing, a piece of 4 cm long 16 gauge solid copper wire that touches the ball bearing is inserted. By resting the wire on the ball bearing, the end of the wire will be just short of the front surface of the electrode. The wires are held centered in the hole and the holes are filled with a high temperature (use temperature  $>200^{\circ}\text{C}$ ) conducting epoxy (volume resistivity of less than  $2 \times 10^{-3} \Omega \text{ cm}$ ). Emerson & Cuming Specialty Polymers ECCOBOND SOLDER 58C has been found to be sufficient for these purposes. After the epoxy has been B-staged (80% complete cure), the bearing is removed and curing is completed.



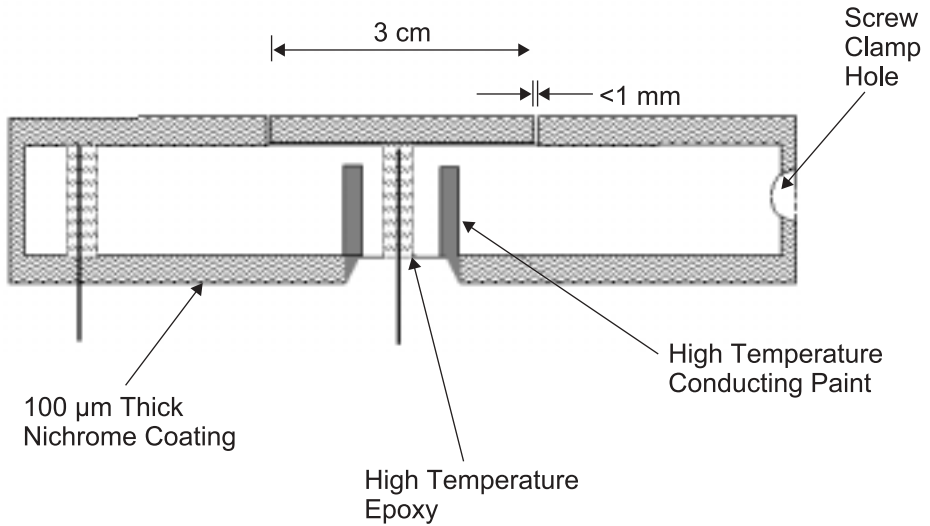
**Figure 1.** Fused quartz blank electrode construction. Note that the drawing is not to scale; the supplied measurements should be used. (The diameter of the blank is 10 cm as specified in the text.)

## ◆ Capacitance Cell Measurement

### Top Electrode



### Bottom Electrode



**Figure 2.** Electrode construction showing the nichrome coating, placement of the copper wires, conducting paint, and one of the three screw clamp holes. Note that the drawing is not to scale; the supplied measurements should be used.

A nichrome coating (see Figure 2) is applied such that it covers all surfaces except for a small area around the central wire on the back side. The coating is removed on the front sides of both electrodes by scribing on a 3 cm radius (width  $< 0.1$  mm) on the top electrode, and on a 1.5 cm radius on the bottom electrode, to form a guard gap of minimal cross-sectional area. The scribing of these gaps should be performed in such a manner so as to minimize the raising of material. In construction of the electrodes, the main precautions are maintenance of flatness and minimization of the guard gaps. To complete construction, the groove (well) cut in the back of the bottom electrode is then filled with a high-temperature conducting silver paint that touches the nichrome on the outside edge but not the inner electrode, and the paint is cured according to manufacturer's specifications.

### 4.2.2 Holder Construction

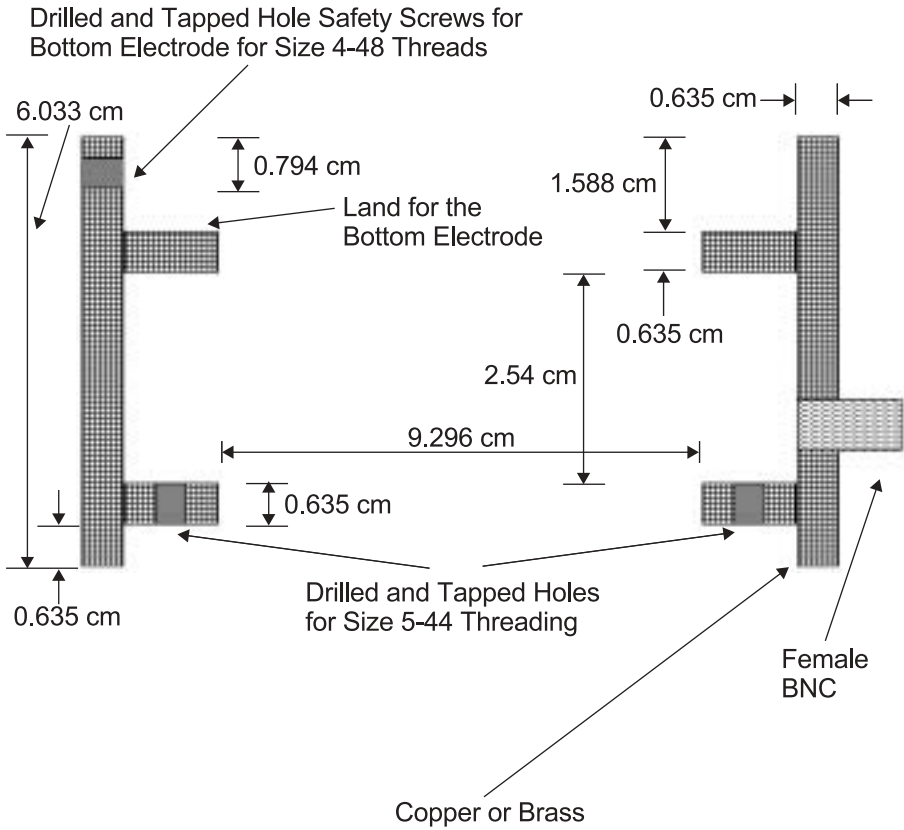
The holder, shown in cross-section in Figures 3, 4 and 5, has a land machined in it, so the bottom electrode can rest on it without any applied force. The drawings show all appropriate dimensions for construction of the holder.

### 4.2.3 Cell Assembly

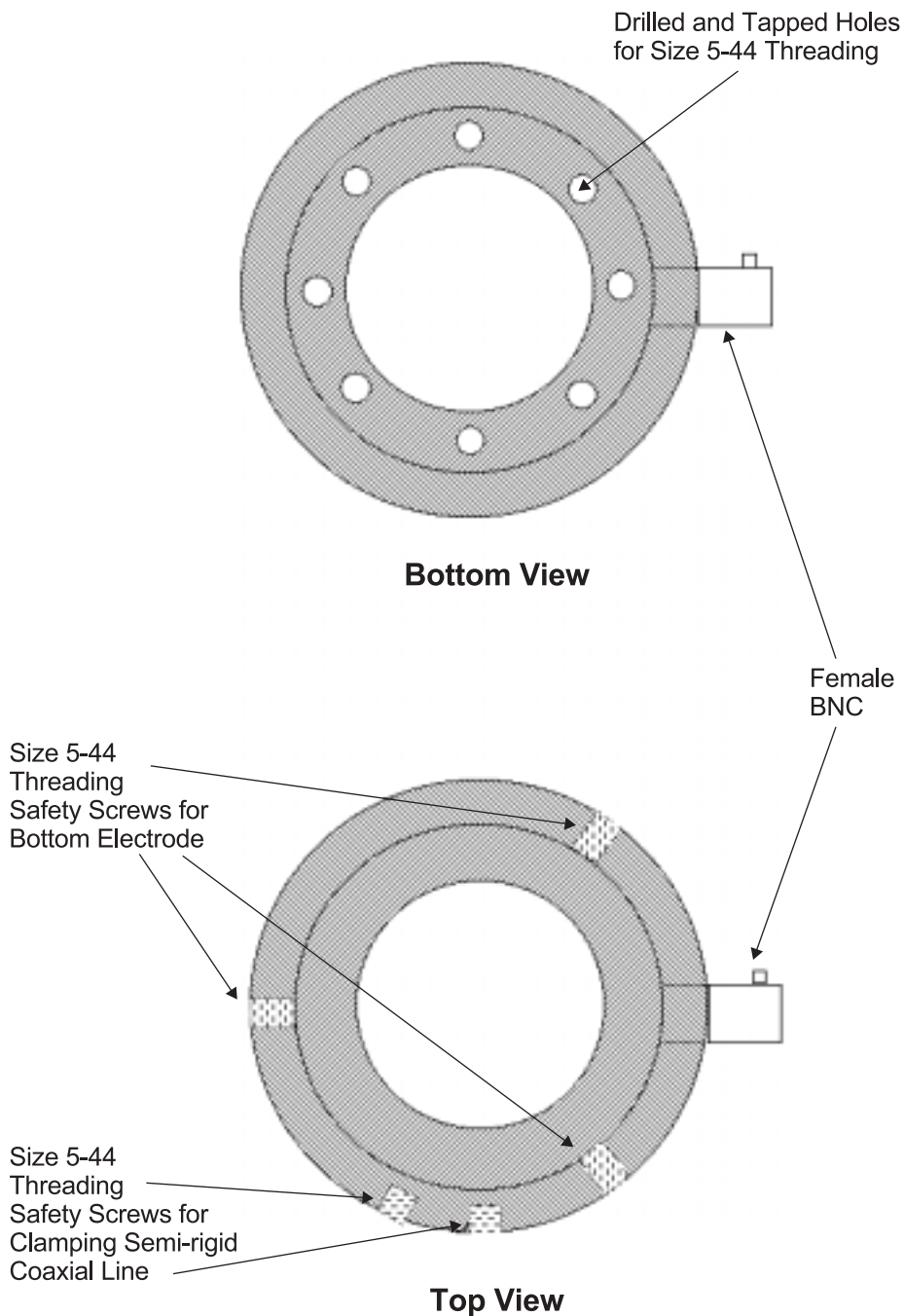
The bottom electrode is set in the holder. The safety screws in the holder are aligned with the indentations in the circumference of the bottom electrode. The screws are tightened until they are finger tight and are then backed off by a  $\frac{1}{4}$  turn to eliminate strain on the electrode. The holder and bottom electrode are then inverted. The shield plate, shown in Figure 6, is then clamped in the bottom of the holder 1 cm away from the bottom electrode with the copper wires passing through the center of the holes in the guard plate. The screws along the radii are finger-tightened to hold the shield plate in place.

The coaxial bridge low lead is made from poly(tetrafluoroethylene) insulated coaxial cable attached at one end to a BNC receptacle in the holder using high-temperature solder with a melting point above  $250^{\circ}\text{C}$ . The other end is clamped to the shield plate placed between it and the bottom of the electrode. Fine 30-gauge wire coil soldered, using the high-temperature solder, to the poly(tetrafluoroethylene) insulated cable is used to complete the contact to the electrodes to eliminate any thermally-induced strains from the teflon insulation of the cable.

## ◆ Capacitance Cell Measurement

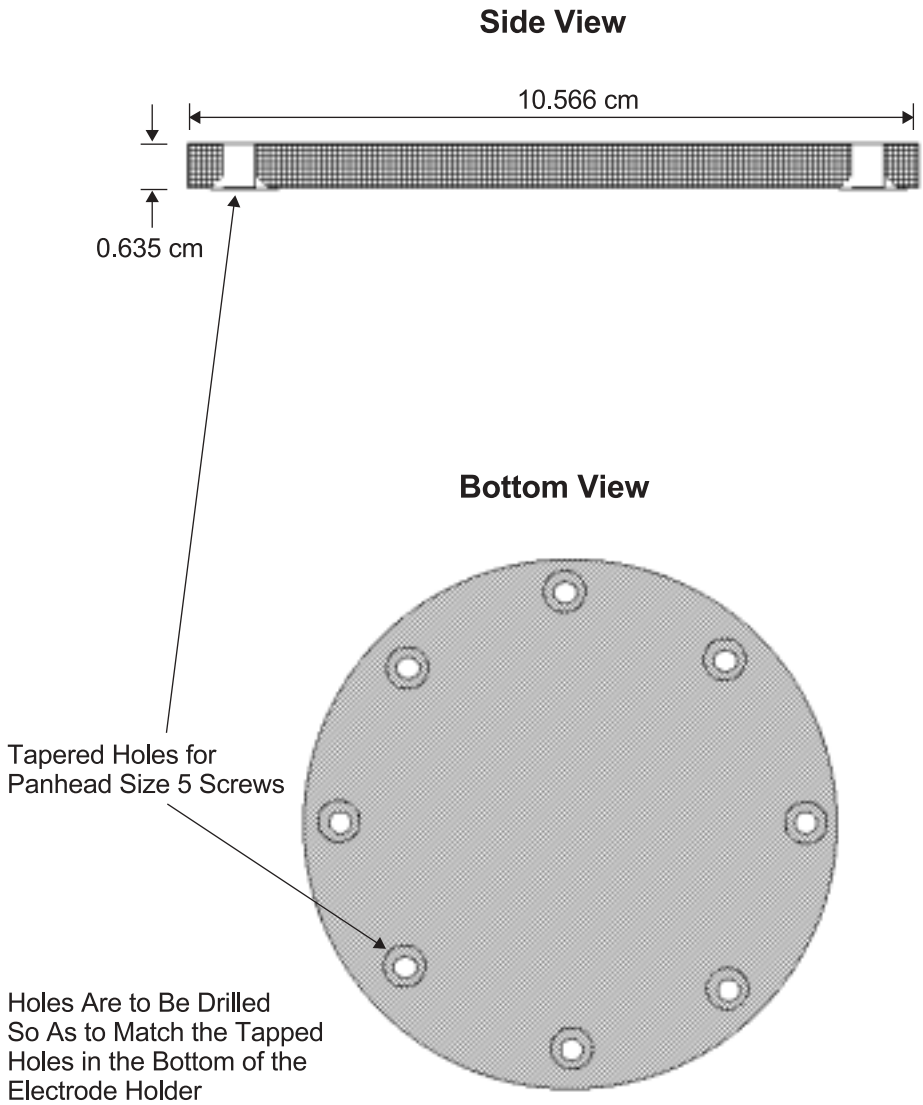


**Figure 3.** Cross-sectional view of the dimensions for construction of the electrode holder. The materials for the cell holder are brass or copper. Note that the drawing is not to scale; the supplied measurements should be used.



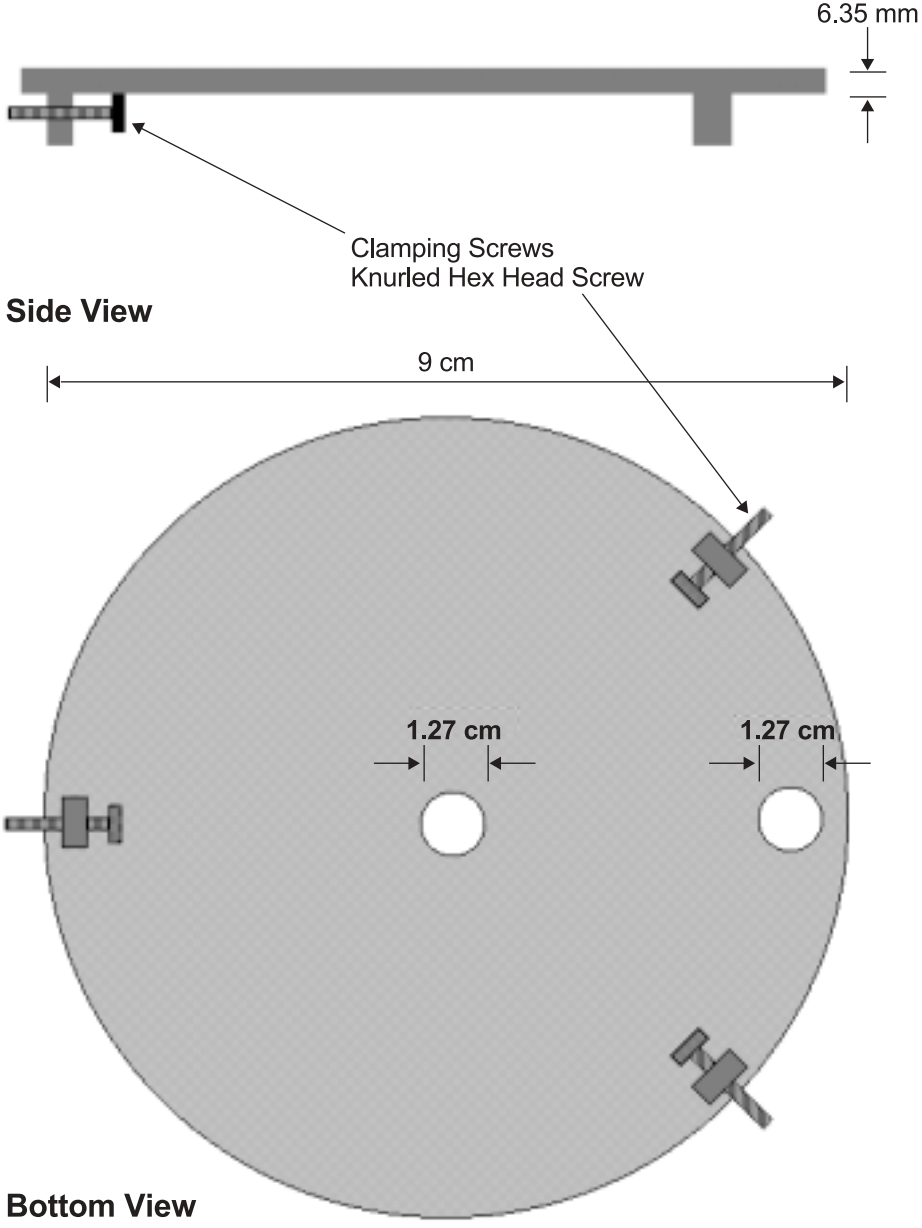
**Figure 4.** Top and bottom views of the electrode holder. The materials for the cell holder are brass or copper. Note that the drawing is not to scale; the supplied measurements should be used.

## ◆ Capacitance Cell Measurement



**Figure 5.** Side and bottom views of the dimensions for construction of the electrode holder's bottom cover plate. Note that the drawing is not to scale; the supplied measurements should be used.





**Figure 6.** Side and bottom views of the dimensions for construction of the aluminum shield plate. Note that the drawing is not to scale; the supplied measurements should be used.

## ◆ Capacitance Cell Measurement

Actual connection is made by a push-on connection (which had the 30-gauge wire soldered to it using the high-temperature solder) using center female contacts from 50  $\Omega$  BNC connectors. The center conductor of the BNC receptacle connects with the center wire in the electrode and the “braid”/outer connector with the outer wire in the electrode. The above electrical connections are diagrammed in Figure 7. The cover plate shown in Figure 5 is then placed on the bottom and is fastened to the holder with pan head screws. The BNC receptacle is connected to the capacitance bridge by low-noise, high-temperature coaxial cable.

A miniature semirigid copper clad 50  $\Omega$  coaxial line (equivalent to Pasternack Enterprises part number PE3823-18) clamped to the side of the holder is used to make contact with the top electrode. The center conductor connects to the center wire and the braid to the outer wire on the electrode. This lead is connected by low-noise, high-temperature coaxial cable to the high terminal of the capacitance bridge. This lead overhangs the electrode and also makes contact through fine copper coils. These coils do not need any shielding as the connection to the bottom electrode is completely shielded from it by the holder. In this way, all thermally induced strains from the connections are minimized without compromising the necessary shielding. See Figure 8 for a diagram of the completely-assembled cell.

### 4.3 Accessories

The following or equivalent are recommended:

#### 4.3.1 Coaxial Cable

Use low-noise, high-temperature insulated cables with high-quality connectors equivalent to Kistler Corporation Model 1635C(X) coaxial cable.

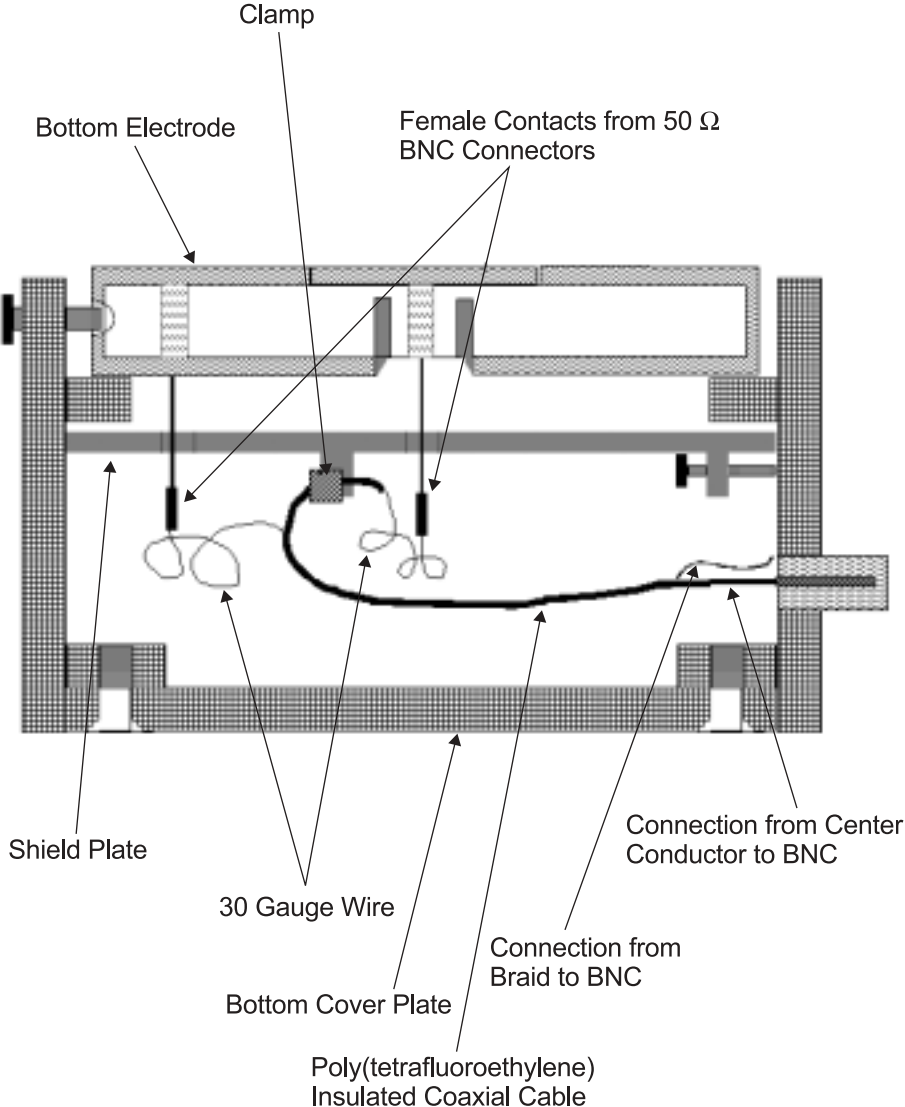
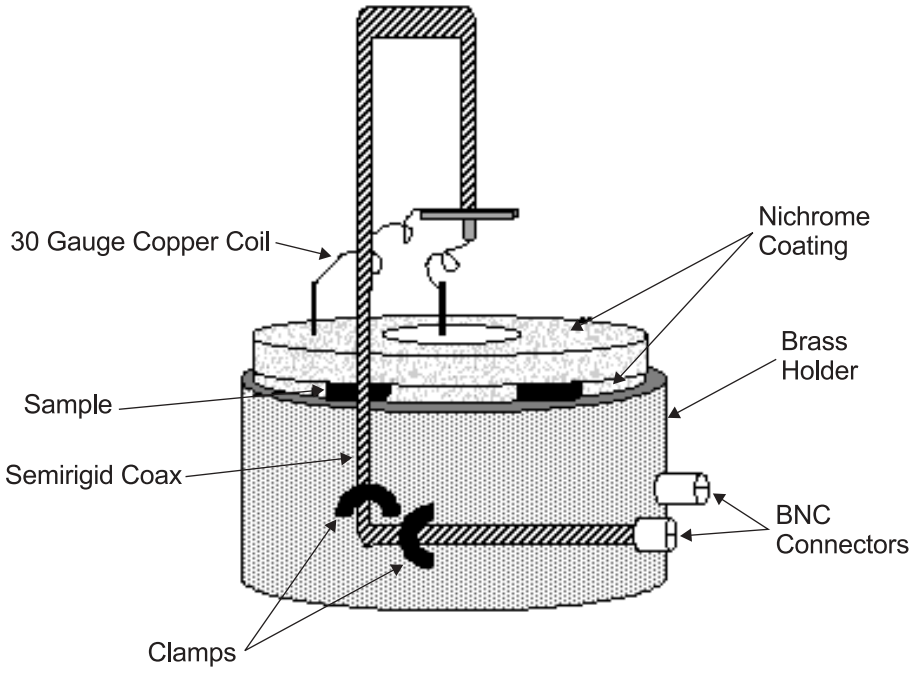


Figure 7. Schematic of electrical connections to bottom electrode.

## ◆ Capacitance Cell Measurement



*Figure 8. Diagram of assembled capacitance cell.*

## 5. Procedure

The process of experimentally determining the CTE consists of two procedures — calibration and specimen tests. Calibration needs to be performed only once after the sample cell has been constructed. For all measurements, three specimens are need for each run. The specimens should be as free from dust and surface contamination as possible. Cell assembly should be performed in the laminar flow hood or cleanroom. The electrode surfaces are cleaned with distilled water followed by ethanol and dried with lens tissue. High pressure filtered air is used to remove any remaining particles from the surface. All samples are cleaned in the same way unless they are soluble or swell in the presence of ethanol or water. The samples are placed on the bottom electrode at the outer edge of the outside guard ring and are spaced  $2\pi/3$  radians ( $120^\circ$ ) apart. The entire cell apparatus is then placed in the vacuum oven at  $25^\circ\text{C}$  at a pressure of less than 1 kPa for 1 h. (Evacuation of the cell is necessary to simulate wringing, i.e., the removal of the trapped air layer caused by the contact of optically smooth surfaces.)

### 5.0a Thermal Expansion

The assembled cell is transferred to an oven equipped with a dry air purge. The cell is equilibrated  $10^\circ\text{C}$  above the highest temperature of interest for approximately 1 h. Measurements are performed after the cell assembly has dimensionally equilibrated. Dimensional equilibration is determined by the calculated thickness (defined below) changing by a relative value of less than  $1 \times 10^{-6}$  over a period of 1 h with measurements being performed every 10 min or less (the process can be automated with all measurements performed by a computer). It should be noted that dimensional equilibration will occur either with, or after, thermal equilibration — the latter occurring when the material undergoes volume recovery or some other relaxation process.

The thickness of the sample ( $d$ ) is given by the following equation (with all constants given in SI units):

$$d = \frac{\epsilon_0 A}{C} \left[ \frac{2(Pp/RT) + 1}{1 - (Pp/RT)} \right] \quad (1)$$

where:

$\epsilon_0 = 8.854 \text{ pF/m}$  is the permittivity of free space

$R = 8.314507 \text{ L kPa mol}^{-1} \text{ K}^{-1}$  is the gas constant

## ◆ Capacitance Cell Measurement

$P = 4.31601 \times 10^{-3}$  L/mol is the molar polarization of dry air<sup>[13]</sup>

$C$  = the measured capacitance

$p$  = the measured atmospheric pressure

$T$  = the cell temperature

$A$  = the effective electrode area, which is a function of temperature and must be calibrated

The temperature is then changed and the cell is re-equilibrated.

### 5.0b Hygrothermal Expansion

The cell is transferred to an environmental chamber that has been pre-equilibrated to the initial temperature ( $T$ ) and relative humidity ( $H_R$ ) of interest. The thickness of the sample is given by<sup>[14]</sup>:

$$d = \frac{\epsilon_0 A}{C} \epsilon \quad (2)$$

where  $\epsilon$  is the dielectric constant of the air in the gap between the electrodes, determined by the sample thickness. The determination of  $\epsilon$  is given in Appendix A. It is easily shown that under dry conditions,  $\epsilon$  reduces to the form in brackets in Eq. (1).  $T$  and/or  $H_R$  are then changed and the cell is re-equilibrated.

### 5.1 Calibration

Calibration of the cell involves determination of the effective electrode area  $A$  as a function of temperature  $T$ . The specimens used for the calibration must have a CTE ( $\alpha$ ) of less than  $0.05 \times 10^{-6}$  m/m and be dimensionally stable (i.e., do not significantly deform under loading). Zerodur has been found satisfactory for this purpose.<sup>[15]</sup> Flat samples with a thickness of approximately 2 mm should be used. The specimens should be measured with the caliper at room temperature, and room temperature should be measured to  $\pm 0.1^\circ\text{C}$ . The value for the approximate room temperature thickness is determined by averaging the three sample thicknesses. While the uncertainty with this calculation will limit the absolute thickness values, it will not affect the uncertainty in the expansion values.

The procedure in Section 5.0 is followed and measurements are performed over the entire temperature range of interest with a minimum of five different temperature measurements. The rearranged form for Eq. (1) that is used for calibration of  $A$  is:

$$A = \frac{C}{\epsilon_0} \left[ \frac{1 - (Pp/RT)}{[2(Pp/RT) + 1]} \right] [d_{rt} + d_{rt}\alpha(T - T_{rt})] \quad (3)$$

where:

$d_{rt}$  = average calibration specimen thickness at room temperature

$T_{rt}$  = room temperature

$\alpha$  = CTE of the calibration specimen material

From the measured area ( $A$ ) as a function of temperature, the radius ( $r$ ) is determined from:

$$r = \sqrt{A/\pi} \quad (4)$$

The ( $r$ ,  $T$ ) data is then fit by a linear least squares process, which is available in most spreadsheets, to a quadratic equation of the form:

$$r = A_1T^2 + A_2T + A_3 \quad (5)$$

(It should be recalled that “linear” in the linear least squares refers to linearity in the coefficients not a linear equation.) Equation (5) is used to determine the area in Eqs. (1) and (2) as a function of temperature used in all subsequent sample measurements.

The calibration run should also be used as a verification of expected reproducibility. The reproducibility of thickness on temperature cycling should be on the order of  $2 \times 10^{-6}$   $\mu\text{m}/\mu\text{m}$  under dry atmosphere conditions. If the reproducibility is an order of magnitude greater than this, either there are problems with the connections in the cell, there is too much vibration in the environmental chamber, or there is a problem with the user’s technique. See Note 6.4 for suggested “debugging” techniques.

### 5.2 Test Measurements

The  $x$ - $y$  dimensions of each of the samples are measured (to determine the total surface area), and the mass of the top electrode is determined using the analytical balance. The nominal loading ( $Force/Area$ ) is then determined by the following equation:

$$Loading = \frac{Force}{Area} = \frac{mg}{x_1y_1 + x_2y_2 + x_3y_3} \quad (6)$$

Where:

$m$  = Mass of the top electrode

$g = 9.80 \text{ m/s}^2$ , the gravitational acceleration constant

$x_1, y_1$  =  $x$  and  $y$  dimensions of sample 1, respectively

$x_2, y_2$  =  $x$  and  $y$  dimensions of sample 2, respectively

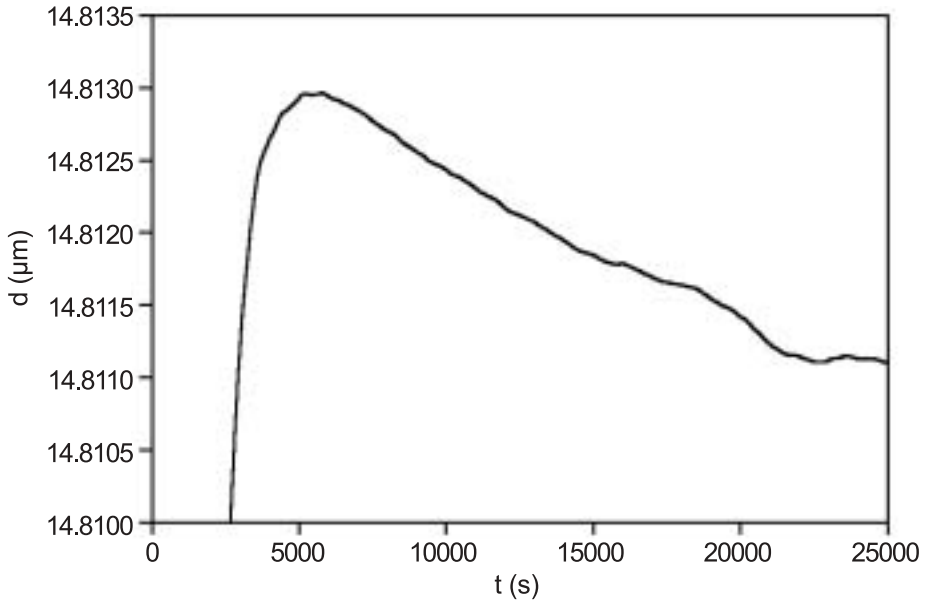
$x_3, y_3$  =  $x$  and  $y$  dimensions of sample 3, respectively

The capacitance cell is loaded with the three specimens and measured at a minimum of five temperatures in the manner described in Section 5.0. The temperatures must be measured in a fixed step decreasing order.

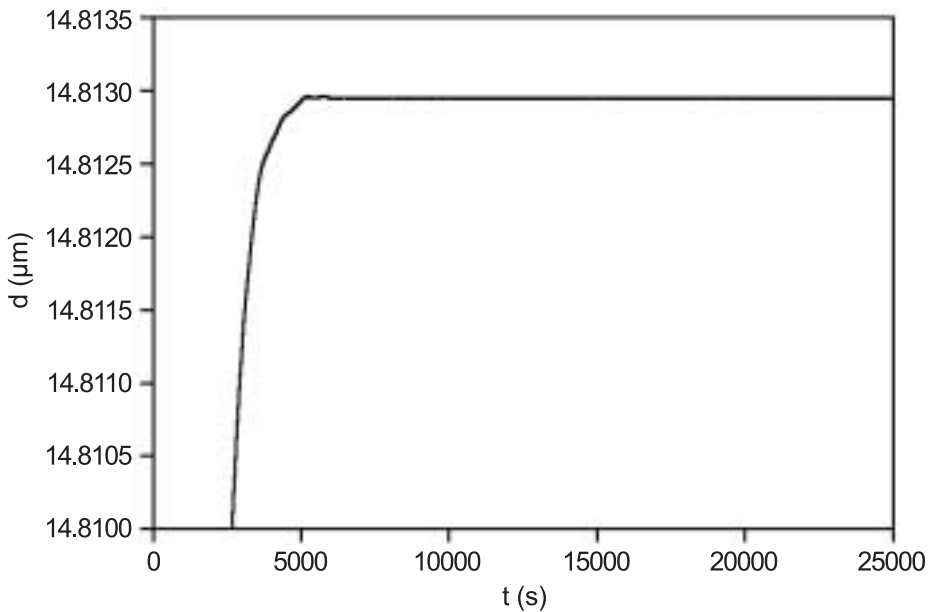
### 5.3 Evaluation

It must be determined whether or not dimensional changes have occurred during the sample run. If the thickness ( $d$ ) versus time ( $t$ ) plot appears like Figure 9 rather than Figure 10, then creep effects are present. The former curve is a convolution of the thermal equilibration process and viscoelastic or plastic deformation of the sample. An estimation of the thermal equilibration time can be made by using samples of known thermal conductivity and diffusivity that are dimensionally stable and using the appropriate heat transfer equations as could be found for example in references 16 and 17. Viscoelastic or plastic deformations are more difficult to correct for — one approximate method is given in Ref. [10].





**Figure 9.** Typical thickness versus time plot for a material that undergoes dimensional contraction (creep) under load after a temperature step. (This plot is given to aid the reader only; it should not be interpreted as actual data.)



**Figure 10.** Typical thickness versus time plot for a material that does not undergo dimensional contraction (creep) under load after a temperature step. (This plot is given to aid the reader only; it should not be interpreted as actual data.)

## ◆ Capacitance Cell Measurement

### 5.4 Calculation of Coefficient of Thermal Expansion

To determine the CTE, the relative expansion is calculated using a reference temperature near room temperature (preferably 20°C or 25°C). The relative expansion data are then given by:

$$E_T = \frac{d_T - d_{ref}}{d_{ref}} \quad (7)$$

where:

$E_T$  = the relative expansion at temperature  $T$

$d_{ref}$  = the thickness at the reference temperature

The expansion data are then fit by a linear least squares procedure to a cubic polynomial of the form:

$$E_T = B_1T^3 + B_2T^2 + B_3T + B_4 \quad (8)$$

The CTE is then given by:

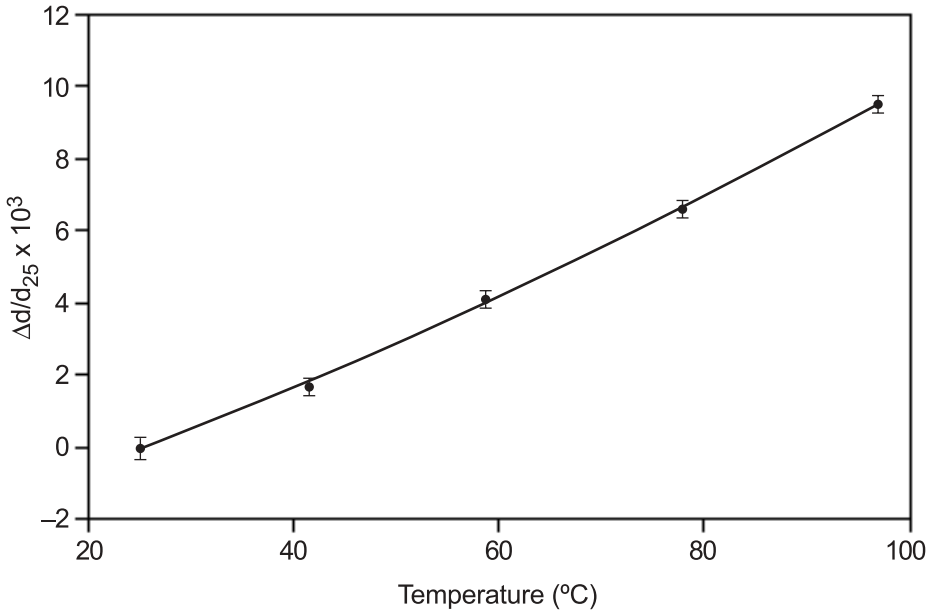
$$\alpha = \frac{dE}{dT} = 3B_1T^2 + 2B_2T + B_3 \quad (9)$$

### 5.5 Report of CTE Data

**5.5.1** Report Eq. (9) along with the standard deviation in the coefficients.

**5.5.2** Report the mean value for the CTE calculated by Eq. (9) using a temperature halfway between the highest and lowest measured temperatures.

**5.5.3** Report the reference temperature.



**Figure 11.** Typical relative expansion curve. (This plot is given to aid the reader only; it should not be interpreted as actual data.)

**5.5.4** Report the temperatures that were measured.

**5.5.5** Report the applied loading [Eq. (6)].

## 5.6 Plot of CTE Data

**5.6.1** Plot the relative expansion ( $\mu\text{m}/\text{m}$ ) versus temperature ( $^{\circ}\text{C}$ ) for the specimen, such as is shown in Figure 11. Include a curve generated from the cubic fit [Eq. (8)].

### 6. Notes

- 6.1** Examine the samples after the test. If the sample shows signs of excessive load or distortion, a repeat run should be performed in which the length of the samples are increased by a factor of two which will result in a decreased pressure.
- 6.2** Better estimates of the reproducibility of expansion data can be obtained by performing multiple temperature cycles in the calibration procedure. The difference between subsequent measurements at the same temperature shows the degree of reproducibility achievable with the material under test.
- 6.3** The dissipation factor ( $D = \tan \delta$ ) measured by the capacitance bridge should be less than  $1 \times 10^{-4}$  rad if all of the electrical contacts have been made properly.

### 6.4 “Debugging” a Reproducibility Problem

The first thing to check is cell assembly. The resistances of the connections should be measured using a digital voltmeter. The bottom electrode should be checked while connected to the holder. One lead should be connected to the center conductor of the BNC receptacle in the holder. A piece of soft lead-based solder is then curved, and the curve is touched to the surface of the nichrome inner electrode while the other voltmeter lead is clamped to the piece of solder. (Repeat for the outer conductor of the BNC receptacle and the nichrome outer electrode.) If the resistance is higher than approximately  $50 \Omega$ , there is a problem with the electrical connection. This should be traced down by disassembling the cell and checking each connection: BNC receptacle to 30 gauge coil and copper lead from the back side of the bottom electrode to the nichrome surface. A similar check is performed with the top electrode. If all electrical connections are within the above-specified tolerance, then vibration must be examined as a problem. A metal box can be employed so that the airflow over the cell is reduced to eliminate some vibration. A sheet of silicone rubber can be used between  $-50^\circ\text{C}$  and  $100^\circ\text{C}$  underneath the cell to minimize vibration. If this does not eliminate the reproducibility problem, then the user should examine their technique for assembling the cell and performing the measurements to try to find the reason behind the uncertainty.

A check should also be made to ensure that the 30 gauge wires have remained soft coils and cannot exert any significant strain on the electrodes. If they stretched out, this may introduce a reproducibility problem.

## APPENDIX A — DIELECTRIC CONSTANT OF AIR

To determine the dielectric constant of air containing water vapor, we first need to determine the molar volumes of the water vapor and air. Dry air can be treated as an ideal gas over the range of temperatures from  $-50^{\circ}\text{C}$  to  $150^{\circ}\text{C}$ . The molar volume of dry air is given by:

$$v_{air} = \frac{RT}{p_{air}} \quad (10)$$

where  $p_{air}$  is the partial pressure of air.

$$p_{sat} = \left[ \frac{F_0}{T_{chamber}} + F_1 + F_2 T_{chamber} + F_3 T_{chamber}^2 + F_4 \ln(T_{chamber}) \right] \quad (11)$$

yields the saturation pressure of water in units of Pascal, where

$F_0 = -6043.6117 \text{ K}$ ,  $F_1 = 18.9318833$ ,  $F_2 = -2.8238594 \times 10^{-2} \text{ K}^{-1}$ ,  $F_3 = 1.7241129 \times 10^{-5} \text{ K}^{-2}$ , and  $F_4 = 2.858487$ , at temperature  $T_{chamber}$  – the temperature of the environmental chamber in Kelvin.<sup>[18]</sup> (Note that where no subscript is present on  $T$ , it refers to the temperature of the capacitance cell.) The partial pressure of water ( $p_w$ ) is then calculated by:

$$p_w = p_{sat} H_R \quad (12)$$

where  $H_R$  is the relative humidity with values ranging from 0 to 1. The molar polarization of water is temperature-dependent and is given in the literature to be<sup>[13]</sup>:

$$P_w = \frac{20.847 \text{ K L mol}^{-1}}{T} + 0.0039 \text{ L mol}^{-1} \quad (13)$$

The partial pressure of air is:

$$p_{air} = p_{atm} - p_w \quad (14)$$

where  $p_{atm}$  is the barometric (atmospheric) pressure. The compressibility factor for saturated water vapor ( $z = pv/RT$ ) can be fit to a cubic equation between  $0^{\circ}\text{C}$  and  $150^{\circ}\text{C}$ , i.e.,

## ◆ Capacitance Cell Measurement

$$z = \frac{Pv}{RT} = AT^3 + BT^2 + CT + D \quad (15)$$

where  $A = -1.026 \times 10^{-8} \text{ } ^\circ\text{C}^{-3}$ ,  $B = -1.289 \times 10^{-7} \text{ } ^\circ\text{C}^{-2}$ ,  $C = -3.382 \times 10^{-5} \text{ } ^\circ\text{C}^{-1}$ , and  $D = 0.9998$ .<sup>[11,19]</sup> The compressibility factor increases towards unity at lower relative humidities, therefore the relative humidity corrected value of the compressibility factor must be utilized. The corrected value ( $z'$ ) is<sup>[20]</sup>:

$$z' = 1 - (1 - z)H_R \quad (16)$$

The molar polarizability per unit volume is then given by:

$$\frac{P_w}{v_w} = P_w \times \left( \frac{P_w}{z'RT} \right) \quad (17)$$

We assume additivity for the molar polarizabilities, i.e.,

$$P_{total} = \left( \frac{P_w v}{v_w} \right) + \left( \frac{P_{air} v}{v_{air}} \right) = P_w \chi_w + P_{air} \chi_{air} \quad (18)$$

where  $\chi_i$  is the mole fraction of the  $i^{\text{th}}$  component. Rearranging Eq. (18) to obtain  $P_{total}/v$  yields:

$$\frac{P_{total}}{v} = \left( \frac{P_w}{v_w} \right) + \left( \frac{P_{air}}{v_{air}} \right) \quad (19)$$

and from this, the dielectric constant of the medium can be calculated through the definition:

$$\epsilon = \frac{\left( \frac{2P_{total}}{v} \right) + 1}{1 - \left( \frac{P_{total}}{v} \right)} \quad (20)$$

## APPENDIX B — DISCUSSION OF UNCERTAINTIES

### B.1. Electrode Tilt

An advantage of this cell is that any uncertainties due to the small amount of tilt caused by sample variations will not significantly affect the results. By simple symmetry arguments, it can be shown that any deviations due to a lack of parallelism enter as the square of the tilt angle. For thin films placed between 5 cm diameter plates, the maximum possible angle is so small, approximately  $1 \mu\text{m}/5 \text{ cm}$ , that any variation in this angle is well beyond any possible experimental resolution.

### B.2. Temperature and Pressure Uncertainties

Under dry atmosphere conditions, the effect of an uncertainty in measured temperature and pressure can be easily determined. For a  $1^\circ\text{C}$  standard uncertainty in temperature, the combined standard uncertainty in thickness is obtained by differentiating Eq. (1) with respect to temperature, i.e.,

$$\frac{d}{dT}(d) = \frac{-3\epsilon_0 APpR}{C(Pp - RT)^2} \quad (21)$$

For a  $1^\circ\text{C}$  standard uncertainty at  $25^\circ\text{C}$  and  $101.325 \text{ kPa}$ , for a  $100 \text{ mm}$ -thick sample, the relative expanded uncertainty in thickness is approximately  $2 \times 10^{-6}$ . Better control of the temperature (as required by this guide) reduces this uncertainty by an order of magnitude.

A similar equation can be derived for the combined standard uncertainty in pressure, i.e.,

$$\frac{d}{dp}(d) = \frac{3\epsilon_0 APRT}{C(Pp - RT)^2} \quad (22)$$

For a  $0.13 \text{ kPa}$  ( $1 \text{ torr}$ ) standard uncertainty in pressure, the relative combined standard uncertainty is approximately  $5 \times 10^{-7}$  under the same conditions given above.

The uncertainties caused by moisture are an order of magnitude greater. In Ref. [11], we plotted the combined standard uncertainty  $d\epsilon/dH_R$  at  $60^\circ\text{C}$  as a function of  $H_R$ . At  $80\%$  relative humidity, the relative combined standard uncertainty in the thickness is approximately  $25 \mu\text{m}/\text{m}$ .

### B.3. Thickness Dependence of the Effective Area

The effective area  $A$  was determined for a thickness of approximately 2 mm. This effective area decreases as the film thickness decreases due to a decrease in the fringing fields. The amount of the decrease can be calculated under certain limiting cases. For the case examined here where the dielectric constants of the substance between the electrodes (air) and the substance in the guard gap (air) are equal and where we assume a thick electrode, the thickness correction factor is<sup>[21,22]</sup>:

$$\xi_d = \frac{t}{R} \left( 1 + \frac{R}{t} - \frac{2\delta}{t} \right) \quad (23)$$

where:

$$\frac{2\delta}{t} = \frac{2}{\pi} \tan^{-1} \left( \frac{t}{2d} \right) - \frac{2d}{\pi t} \ln \left[ 1 + \left( \frac{t}{2d} \right)^2 \right] \quad (24)$$

and where  $R$  is the electrode radius,  $d$  is the sample thickness, and  $t$  is the guard gap width. The measured sample thickness [derived from Eq. (1)] is multiplied by the correction factor corresponding to that sample thickness and is divided by the correction factor corresponding to the calibration sample thickness described in Section 5.1.

This correction is necessary only for reducing the error in the absolute thickness, since it is minimized in the relative expansion computation [Eq. (7)]. However, it should be realized that there is some uncertainty introduced into the relative expansion due to the change in the effective area induced by thermal expansion. To determine the magnitude of this combined standard uncertainty,  $d$  in the above equation is replaced by:

$$d = d_0 + \alpha d_0 T \quad (25)$$

where, for ease of computation, we have set the reference state as 0 K. If we then differentiate with respect to temperature, we obtain:

$$\frac{d\xi_d}{dT} = \frac{2\alpha d_0}{\pi R} \ln \left[ 1 + \frac{g^2}{(2d_0 + 2\alpha T d_0)^2} \right] \quad (26)$$



To examine the maximum combined standard uncertainties associated with this, we assume a CTE ( $\alpha$ ) of  $200 \times 10^{-6} \text{ K}^{-1}$ . We then set  $g = 0.1 \text{ mm}$ ,  $R = 1.5 \text{ cm}$ , and  $T = 200 \text{ K}$  (the maximum temperature range for this system, i.e., from  $-50^\circ\text{C}$  to  $150^\circ\text{C}$ ) and solve for  $d_0$  corresponding to the maximum combined standard uncertainty.

The maximum combined standard uncertainty occurs at a thickness of approximately  $25 \text{ }\mu\text{m}$ . The relative combined standard uncertainty is approximately  $67 \times 10^{-6}$  over the entire temperature range (or  $0.335 \times 10^{-6}/^\circ\text{C}$ ). This is then compared to the total relative expansion of the sample  $\alpha T = 4 \times 10^{-2}$ , which indicates that it would introduce a combined standard uncertainty in the calculated CTE of, at most, 0.2% under the worst case possible. This level of uncertainty in the CTE is negligible, and, hence, these contributions to the combined standard uncertainty can be neglected.

#### B.4. Other Sources of Uncertainty with Respect to Thickness Reproducibility

One source of uncertainty that is introduced from three pieces that are not of identical height arises if the sample pieces move during the course of the measurement. If the samples are not in the exact same location and orientation, the mean distance between the electrodes will change simply due to the geometry. This source of uncertainty is minimized by eliminating all sample motion relative to the electrodes. Furthermore, excess vibration should be eliminated as this can introduce a time-dependent thickness variation. In the case of optically smooth samples, the wringing process described previously will minimize sample sliding just due to sample friction.

Our best estimate for the total magnitude of the wrung layer was derived from measurements on <0001> single crystal  $\text{Al}_2\text{O}_3$ . This sample was optically flat and sufficiently rigid that any additional sources of uncertainty were eliminated. From data taken on the sample thickness after initial assembly of the capacitance cell to the thickness after wringing (i.e., after vacuum evacuation — described in Section 5.0), an estimated thickness of greater than  $40 \text{ nm}$  was determined for the combined top and bottom interfaces. However, proper sample handling and conditioning have been shown to eliminate this source of error.

Another source of uncertainty is that due to creep. For many materials, such as filled epoxy resins and polyimides, there is no observable creep near  $25^\circ\text{C}$  and low humidities. However, especially at high temperatures and humidities, the sample can creep, as shown by a downward drift in the total distance after thermal equilibration is achieved. In addition,

## ◆ Capacitance Cell Measurement

there can be dimensional relaxation as well as diffusion-controlled moisture absorption, all on longer time scales than that due to thermal equilibration. Ultimately, these dimensional changes will set the limit as to how well thermal expansion can be defined. Since this is a material based limit, this uncertainty must be estimated for each sample individually and is not due to the measurement cell.

Similarly, any warpage can interfere with the actual measurement. For composite samples with layers of different CTE's in the plane of the sample, warpage can become a problem. This is one case where increased load could help. However, we have observed a highly-stressed sample that formed visible wrinkles over a narrow temperature range. This was manifested as a sudden jump in sample thickness.

Finally, sample flatness becomes an increasing problem when dealing with anisotropic materials. For some liquid crystal polyimides, the thermal expansion can be close to zero in the  $xy$  plane while near  $100 \times 10^{-6} \text{ K}^{-1}$  in the thickness direction. For these materials, sample flatness will become the limit to the estimation of the CTE perpendicular to the  $xy$  plane. As an extreme case, the largest uncertainties due to anisotropy will be if any wrinkles exist (especially if the  $xy$  expansion is small and the  $z$  axis expansion is large) since there will be a convolution of the  $xy$  and  $z$  axis CTE's in the measured CTE. For materials that are not highly anisotropic, this source of uncertainty becomes less important, and in the limit of an isotropic material, the orientation and shape of the sample do not matter.

### **B.5. Capacitance Bridge Calibration**

The calibration of the capacitance bridge for absolute capacitance is not an essential component of these measurements. If the capacitance bridge is stable and linear (as is normally the case with capacitance bridges with oven-stabilized fused quartz references), then once the calibration has been performed, only the relative values of the capacitance will matter. Errors caused by miscalibration of absolute capacitance, or by not correcting for cable length, resistance, etc., will be eliminated in this manner.

**REFERENCES**

1. Storer, R.A., ed. *Annual Book of ASTM Standards*. West Conshohocken: American Society for Testing of Materials, **14.02**, 548 (1997).
2. *IPC-TM-650 Test Methods Manual*. Northbrook: The Institute for Interconnecting and Packaging Electronic Circuits, No. 2.4.24.2.
3. Wu, W., J.H. Van Zanten, and W.J. Orts. "Film Thickness Dependent Thermal-expansion in Ultrathin Poly(methyl methacrylate) Films on Silicon." *Macromolecules*, **28**, 771 (1995).
4. Keddie, J.L., R.A.L. Jones, and R.A. Cory. "Size-Dependent Depression of the Glass-Transition Temperature in Polymer Films." *Europhysics Letters*, **27**, 59 (1994).
5. Ho, P.S., T.W. Poon, and J. Leu. "Molecular-Structure and Thermal-Mechanical Properties of Polymer Thin-Films." *J. Phys. Chem. Solids*, **55**, 1115 (1994).
6. Sao, G.D., and H.V. Tiwary. "Thermal Expansion of Poly(vinylidene fluoride) Films." *J. Appl. Phys.*, **53**, 3040 (1982).
7. Subrahmanyam, H.N., and S.V. Subramanyam. "Thermal Expansion of Irradiated Polystyrene." *J. Mat. Sci.*, **22**, 2079 (1987).
8. Tong, H.M., H.K.D. Hsuen, K.L. Saenger, and G.W. Su. "Thickness Direction Coefficient of Thermal Expansion Measurement of Thin Polymer Films." *Rev. Sci. Instrum.*, **62**, 422 (1991).
9. Patel, K.S., P.A. Kohl, and S.A.B. Allen. "Dual Capacitor Technique for Measurement of Through-Plane Modulus of Thin Polymer Films." *J. Polym. Sci., Polym. Phys.*, **38**, 1634 (2000).
10. Snyder, C.R., and F.I. Mopsik. "A precision capacitance cell for measurement of thin film out-of-plane expansion. I. Thermal expansion." *Review of Scientific Instruments*, **69**, 3889 (1998).
11. Snyder, C.R., and F.I. Mopsik. "A precision capacitance cell for measurement of thin film out-of-plane expansion. II. Hygrothermal expansion." *Review of Scientific Instruments*, **70**, 2424 (1999).
12. Snyder, C.R., and F.I. Mopsik. "A precision capacitance cell for measurement of thin film out-of-plane expansion. III. Conducting and Semiconducting Materials." *IEEE Transactions on Instrumentation and Measurement*, **50**, 1212 (2001).

## ◆ Capacitance Cell Measurement

13. Maryott, A.A., and F. Buckley. "Table of Dielectric Constants and Electric Dipole Moments of Substances in the Gaseous State." *NBS Circular*, **537** (1953).
14. Schwinger, J., L.L. DeRaad, Jr., K.A. Milton, and W. Tsai. *Classical Electrodynamics*. Reading: Perseus Books, 1998.
15. Schott material having a coefficient of thermal expansion of less than  $0.05 \times 10^{-6} \text{ K}^{-1}$ .
16. Incropera, F.P., and D.P. DeWitt. *Fundamentals of Heat and Mass Transfer*. 4<sup>th</sup> ed. New York: John Wiley & Sons, 1996.
17. Carslaw, H.S., and J.C. Jaeger. *Conduction of Heat in Solids*. 2<sup>nd</sup> ed. London: Oxford University Press, 1959.
18. Wexler, A. "Vapor-Pressure Formulation For Water in the Range 0 To 100°C." *J. Res. Natl. Bur. Stand.*, **80A**, 775 (1976).
19. Haar, L., J.S. Gallagher, and G.S. Kell. *NBS/NRC Steam Tables*. New York: Hemisphere, 1984.
20. Glasstone, S. *Thermodynamics for Chemists*. New York: Van Nostrand Company, 1947.
21. Lauritzen, J.I., Jr. "The Effective Area of a Guarded Electrode." 1963 Annual Report, *Conference on Electrical Insulation*, NAS-NRC, pp. 67–70.
22. Thompson, J.J. *Notes on Recent Researchers in Electricity and Magnetism*. Oxford: Clarendon Press, 1893.







