

DESIGN AND FABRICATION OF AN OPERATING ROOM COMPUTER ASSISTED ORTHOPAEDIC HIP SURGERY ARTIFACT

**Nicholas G. Dagalakakis, Yongsik Kim, Daniel Sawyer, Craig Shakarji
Manufacturing Engineering Laboratory
National Institute of Standards and Technology
100 Bureau Dr. Stop 8230
Gaithersburg, MD 20899-8230**

ABSTRACT

Hundreds of thousands of joint arthroplasty operations are performed throughout the world every year, providing life saving relief from pain and return of mobility to the majority of the individuals who have this treatment. Clinical studies have shown that improper position and orientation of the joint implants can result in accelerated rates of failure, less than satisfactory mobility and even joint dislocation or impingement. Computer Assisted Surgery (CAS) systems have been developed in order to advise the surgeon inside the operating room on the proper positioning and orientation of tools and implants during such operations. The objective of the work described in this paper was to develop a simple, lightweight, easy to use operating room high precision artifact (phantom), which can be used at the beginning of orthopaedic hip operations for a quick performance test of most CAS systems.

INTRODUCTION

Computer Assisted Orthopaedic Surgery (CAOS) systems consist of tracking sensors, tracking markers, a computer and other relevant electronics [1]. During an operation the markers are attached to bones, surgical tools and implants. The three-dimensional space position of the markers is determined with respect to a reference frame and based on that information the position and orientation of tools, bones and implants are calculated and used to generate useful surgery information. Comparison of conventional versus CAOS assisted arthroplasty operations have demonstrated that CAOS systems show significant improvement in the desired surgical result. In particular, CAOS systems help reduce the variability of the positioning of prosthetic components from the desired optimum position and orientation, thus permitting more consistent placement of the prosthetic components [2, 3].

It is therefore important that these CAOS systems function reliably and accurately during each surgical operation. We have developed a simple, lightweight, easy to use, operating room high precision artifact, called a phantom by medical professionals, which can be used at the beginning of each operation for a quick performance test of most CAOS systems. A longer and more thorough performance test can be performed early in the morning before the first surgical operation. This phantom can also be use for the calibration of CAOS systems. Calibration is of course primarily the responsibility of the manufacturer of CAOS systems and it can be performed after fabrication and during servicing operations.

Here we will describe the design and fabrication of a Horizontal Joint Operating Room Computer Assisted Orthopaedic Hip Surgery (HJ-OR-CAOHS) phantom.

TOTAL HIP ARTHROPLASTY OPERATION BASICS

Various human diseases and activities can damage the hip joint and lead to severe pain and loss of mobility. Surgery to replace the damaged joint with an artificial one, a prosthesis, is usually the last resort in order to alleviate pain and restore mobility [4]. There are two major categories of joint prostheses, the cemented and the uncemented ones. The cemented joints are attached to the bone with some kind of epoxy cement, while the uncemented joints have a porous external surface where bone can grow in order to attach the prosthesis to the skeletal bone. The hip prosthesis consists of two major parts; the femoral component and the acetabular component (see images in Figure 1 and 2). The femoral component is made of a metal stem and a metal or ceramic ball head and is intended to replace the upper part of the femur bone. The acetabular component is usually made of a concave metal shell cup and a plastic liner. After the pelvis socket is cleaned and reshaped,

usually to a hemisphere, the metal cup is attached. Then the plastic inner liner is added, and the acetabular prosthesis head is inserted into the liner socket. The initial step before the operation is to determine the coordinates of the center of rotation of the hip and ankle joints in order to calculate the length of the leg. This test must be repeated before the conclusion of the operation and adjustments must be made in order for the patient to exit the operating room with the proper length leg, since a portion of his femur bone and pelvis have been removed. Another critical step of this operation is the attachment of the acetabular component of the prosthesis. It has been found that the metal shell cup must be placed with precise angular orientation otherwise the prosthesis could fail due to dislocation, impingement and premature wear. The angles that define the correct angular orientation are defined with respect to the patient's pelvis frontal (coronal) and transverse coordinate planes, which are difficult to locate while the patient is lying on the operating table.

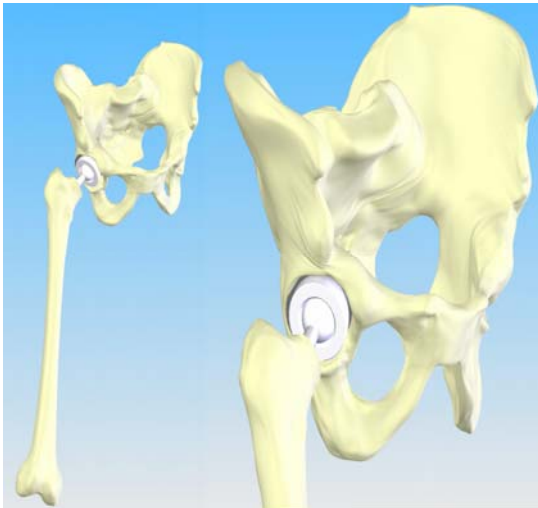

Figure 1. Femoral part of hip prosthesis

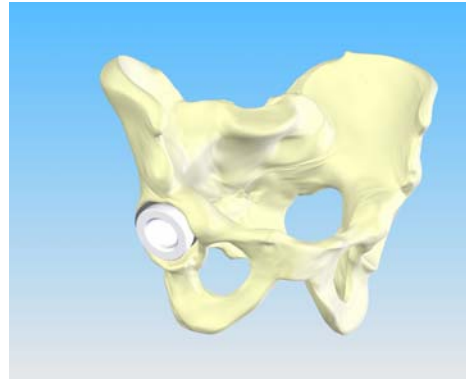

Figure 2. Acetabular part of hip prosthesis

THE HORIZONTAL JOINT COMPUTER ASSISTED ORTHOPAEDIC HIP SURGERY ARTIFACT

For best clinical results our phantoms are designed to resemble the skeletal joint or organ, which is the subject of the operation and the suggested performance tests resemble important tasks of the actual surgical operation. In order to reduce the fabrication and maintenance cost of these devices, we use commercially available precision engineered parts wherever possible in the phantom structure design.

The most important component of the hip joint is the ball and socket joint, which we decided to add to our artifact (phantom). Most ordinary mechanical ball and socket joints have backlash and are difficult to clean and inspect for wear because they are sealed. However, precision engineers use magnetic ball and socket joints (see Figure 3) and bars, which have none of the above mentioned drawbacks. They are commercially available for reasonable prices and are used for the calibration and testing of precision measurement machines, such as Coordinate Measuring Machines (CMM). Furthermore these joints can be fitted with various strength small size magnets, which can be selected for the proper size bar and joint orientation, so that the contact force will be sufficient to ensure that the bar will not separate from the joint socket during the test and not so large that excessive surface wear results.

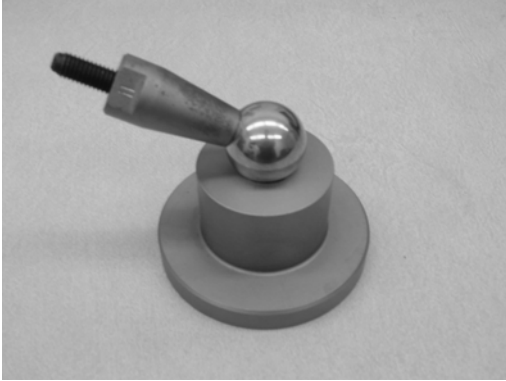

Figure 3. Precision magnetic ball and socket device

Our first HJ-OR-CAOHS phantom resembles a pelvis coordinate frame, as shown in Figure 4, and a femur bone connected with a precision magnetic ball and socket joint, as shown in Figure 5.

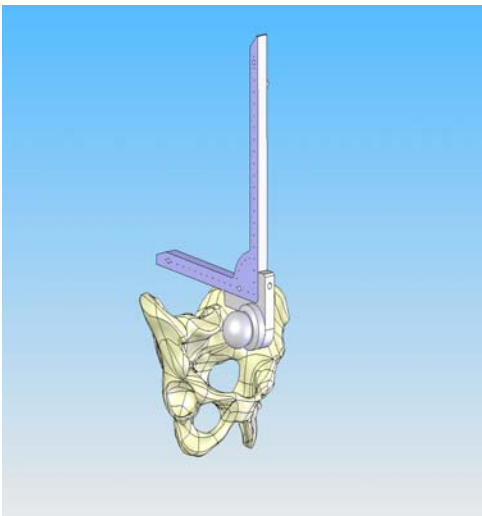

Figure 4. The CAOHS phantom coordinate frame superimposed on a pelvis model. The CAOHS coordinate axes, in this image, are approximately aligned with the pelvis axes (long body and sagittal) used by most medical professionals in order to locate the position and orientation of the pelvis socket (acetabulum).

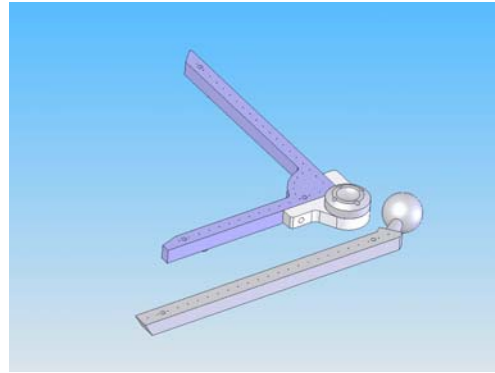

Figure 5. The CAOHS phantom coordinate frame and femur bar connected with a magnetic ball and socket joint

The CAOHS phantoms are designed to perform at least three performance tests relevant to hip arthroplasty operations. They are the following: 1) measure the CAOS system accuracy of determining the location of the coordinates of the center of rotation of the hip joint, represented here by the precision magnetic ball and socket joint, 2) measure the CAOS system accuracy of moving along straight lines at distances comparable to the size of human adult large bones, along two orthogonal directions, 3) measure the CAOS system accuracy of angular moves relevant to orthopaedic hip surgery. If the CAOHS phantoms prove useful for orthopaedic operations, similar devices will be developed for the human knee joint, shoulder joint, etc.

The first HJ-OR-CAOHS phantom has been fabricated (see Figure 6). It is made of an L-shaped horizontal XY orthogonal coordinate frame, a joint horizontal mount, the magnetic ball and socket joint and a femur bar. The XY coordinate frame has small target holes at regular intervals designed to fit the pointed probe tip of the CAOS systems target assemblies. These could be simple plates or Dynamic Reference Bases (DRB) with four or more active or passive markers, which can be mounted on surgical tools.



Figure 6. The first prototype of the HJ-OR-CAOHS phantom

The HJ-OR-CAOHS phantom also has two larger holes for the mounting of DRB target assemblies. The femur bar also has two larger holes for the mounting of DRB target assemblies, which can be used for the determination of the coordinates of the ball center of rotation. The tips of all of the HJ-OR-CAOHS phantom bars are machined to form various angles, which are useful for hip arthroplasty operations. An arc at the base of the coordinate frame has been fitted with target holes spaced at regular angular increments, which adds an additional angular calibration and testing capability. The magnetic ball and socket joint are commercially available and are made of stainless steel material, while the rest of the parts are made of Invar, for better thermal stability inside an operating room.

NIST staff has calibrated all the critical features on the HJ-OR-CAOHS using an industrial grade Coordinate Measuring Machine (CMM). These features include the target hole locations and the center of rotation. In all cases the expanded uncertainty U with $k=2$ in the determination of the three dimensional coordinate is less than 0.08 mm. A future publication will report on the calibration procedures and an additional publication will describe the results of industrial testing.

A new version of the OR-CAOHS, which has an angled magnetic ball and socket joint similar to that of a human pelvis, is also being designed.

CONCLUSIONS

We have designed and fabricated a horizontal joint computer assisted orthopaedic hip surgery phantom (artifact) for the performance testing of CAOS systems inside operating rooms. This device appears to be working very well and it was recently calibrated and sent to a medical research group for testing. Calibration and testing results will be reported in future publications.

KEY WORDS

computer assisted surgery, hip arthroplasty, phantom, artifact.

ACKNOWLEDGEMENTS

We would like to thank Dr. J. B. Stiehl, Dr. D. A. Heck and Dr. W. L. Bargar, for their valuable orthopaedic surgery advice and encouragement. We would also like to thank Mr. Damien Bertot for the laser scanning of several human bone models, Dr. Junhwan Kim for generating solid CAD models of individual bones and assemblies, and Mr. Marvin Kingsbury for the fabrication of the HJ-OR-CAOHS phantom.

REFERENCES

- [1] Knolte LP, Langlotz F, "Basics of Computer-Assisted Orthopaedic Surgery (CAOS)," in the book "Navigation and Robotics in Total Joint and Spine Surgery," by Stiehl JB, Konermann WH, Haaker RG, Publisher Springer-Verlag, 2004.
- [2] Haaker RGA, Tiedjen K, Ottersbach A, Rubenthaler F, Stockheim M, Stiehl JB, "Comparison of Conventional Versus Computer-Navigated Acetabular Component Insertion," J of Arthroplasty, Vol. 22, No. 2, 2007.
- [3] Nogler M, Kessler O, Prassl A, et al. "Reduced Variability of Acetabular Cup Positioning with Use of an Imageless Navigation System," Clin Orthop, Vol. 426, pp 159-163, 2004.
- [4] Thomas BJ, Stiehl JB, "Basics of Total Hip Replacement Surgery," in the book "Navigation and Robotics in Total Joint and Spine Surgery," by Stiehl JB, Konermann WH, Haaker RG, Publisher Springer-Verlag, 2004.