

**Development of the Forward
and Inverse Kinematic Models
for the Advanced Deburring
and Chamfering System
(ADACS) Industrial Robot**

Keith A. Stouffer

Systems Integration Group

U.S. DEPARTMENT OF COMMERCE
Technology Administration
National Institute of Standards
and Technology
Bldg. 220 Rm. B124
Gaithersburg, MD 20899

Development of the Forward and Inverse Kinematic Models for the Advanced Deburring and Chamfering System (ADACS) Industrial Robot

Keith A. Stouffer

Systems Integration Group

U.S. DEPARTMENT OF COMMERCE
Technology Administration
National Institute of Standards
and Technology
Bldg. 220 Rm. B124
Gaithersburg, MD 20899

September 1992



U.S. DEPARTMENT OF COMMERCE
Barbara Hackman Franklin, Secretary

TECHNOLOGY ADMINISTRATION
Robert M. White, Under Secretary for Technology

**NATIONAL INSTITUTE OF STANDARDS
AND TECHNOLOGY**
John W. Lyons, Director

**DEVELOPMENT OF THE FORWARD AND INVERSE
KINEMATIC MODELS FOR THE ADVANCED DEBURRING
AND CHAMFERING SYSTEM (ADACS) INDUSTRIAL ROBOT**

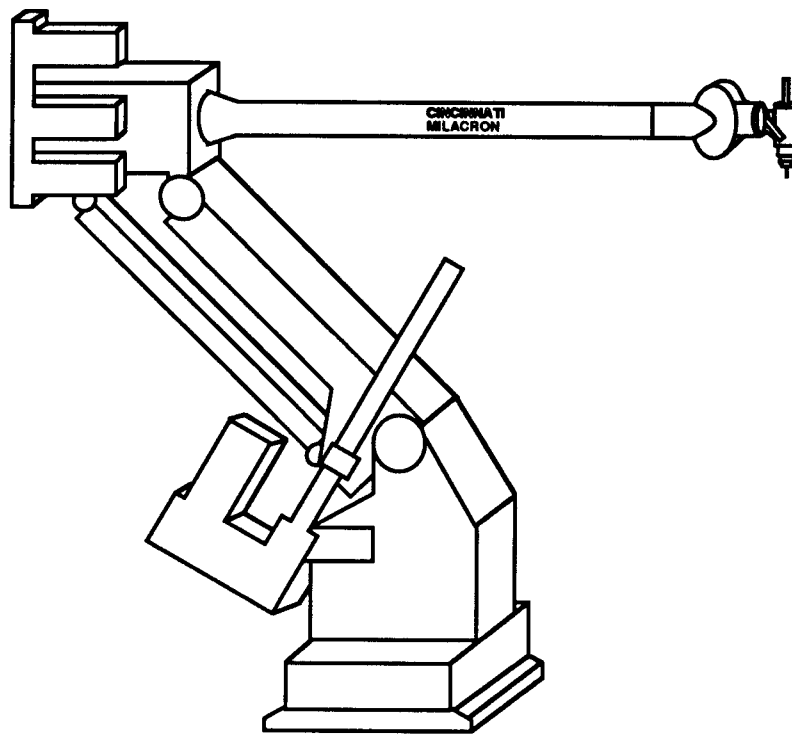

Keith A. Stouffer

**National Institute of Standards and Technology
Robot Systems Division
Systems Integration**

ABSTRACT

The kinematic model for the Advanced Deburring and Chamfering System (ADACS) robot, which determines the position and orientation of the manipulator end-effector for a given set of joint angles, is developed using the standardized Denavit-Hartenberg method as well as an alternative link transform method. The Denavit-Hartenberg notation is described and the parameters for each link are provided in table form. The transform matrix for each link is then derived using these parameters and the mathematical kinematic model is developed. The kinematic model has the form

$$T_6^0 = T_1^0 T_2^1 T_3^2 T_4^3 T_5^4 T_6^5$$

where T_6^0 is a 4 x 4 matrix representation of the position and orientation of the last frame with respect to the base frame.

The inverse kinematic model, which determines the joint value set for a given end-effector position and orientation, is developed from the kinematic model derived using the Denavit-Hartenberg method. The first three joints are solved using a geometric approach. The last three joints are solved for by algebraic and trigonometric manipulation of the rotation part of the transformation matrix.

There are two problems that are dealt with when the inverse kinematic model is solved for. One is the presence of a singularity point in the manipulator. A singularity occurs when two or more joint axes line up causing an infinite number of possible solutions for any given orientation. As the singularity is approached, excessive speed occurs in joint 4 as the wrist "rolls over." A singularity occurs when joint 5 is zero. When a singularity occurs, joint 5 is set to 0, joint 4 is set to its previous value and joint 6 is solved for. There is also an ambiguity in the wrist. There are two solutions for the last three joints for a specific orientation. This ambiguity is referred to as "wrist-flip" and "wrist-no-flip." Because of the wrist ambiguity, there are two possible joint sets for a given position and orientation. The values of joints 1, 2 and 3 are constant for both sets, while there are two possibilities for joints 4, 5 and 6.

1. INTRODUCTION

1.1 ADACS Overview

Research into automating the deburring process has been conducted at the National Institute of Standards and Technology (NIST) since 1983. Research started with the Cleaning and Deburring Workstation (CDWS) which robotically finished parts made of soft metals (aluminum and brass).

A second generation deburring workcell is currently being developed at NIST under a Cooperative Research and Development Agreement (CRDA) with the U.S. Navy and United Technologies Research Center (UTRC). This Advanced Deburring and Chamfering System (ADACS) incorporates a six degree of freedom Cincinnati Milacron T³-646* electric robot as the macromanipulator for an actively compliant deburring tool which serves as the micromanipulator for the system. ADACS is capable of deburring and chamfering aerospace parts (engine hubs and turbine blades) made from high-strength alloys such as inconel. UTRC is modeling the deburring and chamfering process for high-strength alloys. The Navy is looking for an automated system capable of deburring and chamfering these intricate engine hubs and turbine blades manufactured from high-strength alloys.

A robot was chosen over an NC machine for several reasons. To get the necessary manipulations for deburring small complicated parts, at least a five degree of freedom machine is required. Five degree of freedom NC machines are available, but at a much greater expense than a five or six degree of freedom robot. NC machines are also designed to deal with larger chip removal. In deburring of hard metals, very fine metal chips are produced. The shields and protective boots on the NC machine would not prevent these small chips from getting into the machine workings and causing damage.

1.2 Description of T³-646 Robot*

The Cincinnati Milacron T³-646 is a six degree of freedom electric robot with a three roll wrist. The position of the end-effector is determined by the angles of the first three joints and the orientation by the three intersecting joints of the wrist.

1.3 Kinematic Model

A manipulator arm can be described as a series of rigid bodies joined together in a kinematic structure. This linkage, constructed with a serial or "open loop" structure, is referred to as an open kinematic chain. When each link is kinematically described relative to its previous link, a mathematical kinematic model can be developed to determine the position and orientation of the last link with respect to the first link given the angular position of each joint.

1.4 Inverse Kinematic Model

After the mathematical kinematic model has been developed, the inverse kinematic model can be extracted from it. The inverse kinematic model performs the opposite operation of the kinematic model. When the required position and orientation of the end-effector is known, the inverse kinematic model can determine the required angular position for each joint to obtain that position and orientation.

* Product Endorsement Disclaimer

Reference to specific brands, equipment, or trade names in this document are made to facilitate understanding and do not imply endorsement by the National Institute of Standards and Technology.

1.5 Uses for Kinematic Models

The kinematic model will determine the position and orientation of the last frame with respect to the first frame given the angular positions of each of the joints. However, the kinematic model is primarily used to develop the inverse kinematic model which is much more useful in robotic programming. If the robot controller has a joint interface, the joint angles obtained from the inverse kinematic model are fed to the controller to have the robot move to a specified position and orientation. More often than not, the end-effector is required to move to a specified position and orientation. The inverse kinematic model will determine the necessary joint angles to reach the specified goal, and each joint is actuated to the necessary angle.

2 KINEMATIC MODEL

2.1 Kinematics

Kinematics is the science of motion that disregards the forces that cause it. The study of the kinematics of manipulators refers to the geometrical and time-based properties of the motion.

Manipulators consist of rigid links which are connected to each other with joints that allow relative motion of the neighboring links. Position sensors at each joint measure the relative position of neighboring links.

The T³-646 is a six degree of freedom manipulator. The number of degrees of freedom that a manipulator possesses is the number of independent position variables which have to be specified in order to locate all parts of the mechanism. The T³-646 has six revolute joints, and therefore six degrees of freedom.

The kinematic model of the manipulator is a mathematical model that computes the position and orientation of the end-effector with respect to the base frame given a set of joint angles. The kinematic model for the ADACS robot was developed using the standardized Denavit-Hartenberg notation.

2.2 Denavit-Hartenberg Notation

The Denavit-Hartenberg notation was developed as a systematic method of describing the kinematic relationship between a pair of adjacent links involved in an open kinematic chain. The Denavit-Hartenberg method is based on a 4x4 matrix representation of the rigid body position and orientation. A minimum of four parameters are necessary to completely describe the kinematic relationship between links.

In order to obtain the parameters of each link, and therefore describe the location of each link relative to its neighbors, a frame is rigidly attached to each link.

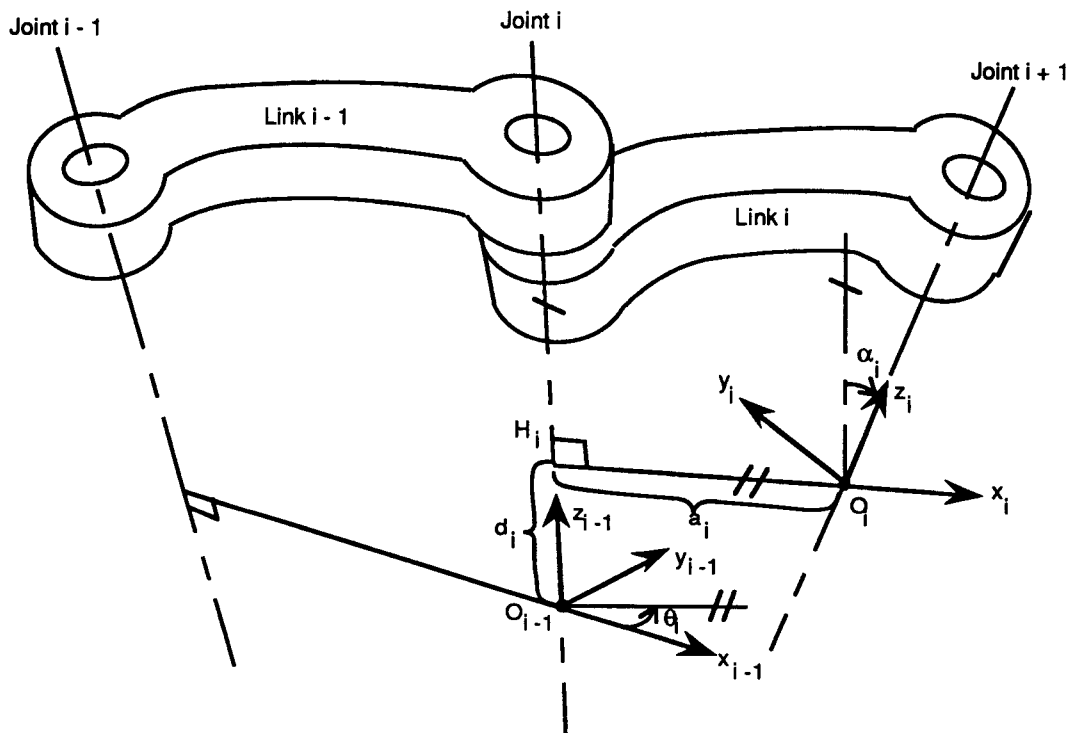

Figure 1: The Denavit-Hartenberg Parameters

Figure 1 shows a pair of adjacent links, link $i-1$ and link i and their associated joints, $i-1$, i , and $i+1$. The convention used to attach the frames on each corresponding link is as follows:

- * The origin of the i -th coordinate frame O is located at the intersection of joint axis $i+1$ and the common normal between joint axes i and $i+1$, as shown in the figure.
- * **NOTE:** The frame of link i is at joint $i+1$ rather than at joint i
- * The X axis is directed along the common normal
- * The Z axis is along the joint axis $i+1$
- * The Y axis is chosen to form a right-hand coordinate system

The relationship between the two frames can be completely described using the following parameters:

- a_i the length of the common normal (the distance from Z_{i-1} to Z_i as measured along X_{i-1})
- d_i the distance between the origin O_{i-1} and the point H_i
- α_i the angle between the joint axis i and the Z_i axis in the right-hand sense
- θ_i the angle between the X_{i-1} and the common normal H_iO_i measured about the Z_i axis in the right-hand sense

There are two constant parameters, α_i and a_i , that are determined by the geometry of the robot link. One of the other two parameters (θ or d) varies as the link moves. If the link is prismatic (adjacent links translate linearly to each other along the joint axis) d will be the variable. If the link has a revolute joint (adjacent links rotate with respect to each other along the joint axis), θ will change as the link moves. In the case of the T³-646 robot, all the joints are revolute, therefore α , a and d remain constant for each individual link while θ changes as the link is moved. Figure 2 shows the relationship between adjacent coordinate frames.

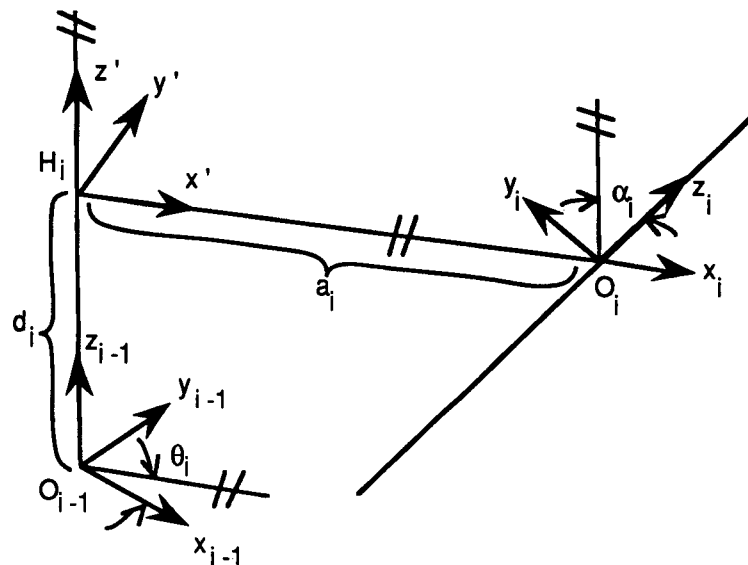

Figure 2: The relationship between adjacent coordinate frames in the Denavit-Hartenberg notation

2.3 Denavit-Hartenberg Frames for T³-646

Using the Denavit-Hartenberg notation, frames are attached to each link of the robot. After the links are attached, the parameters can be determined for each link. Figure 3 shows the assigned frame for each link of the robot. The parameters determined from these frames are shown in Table 1.

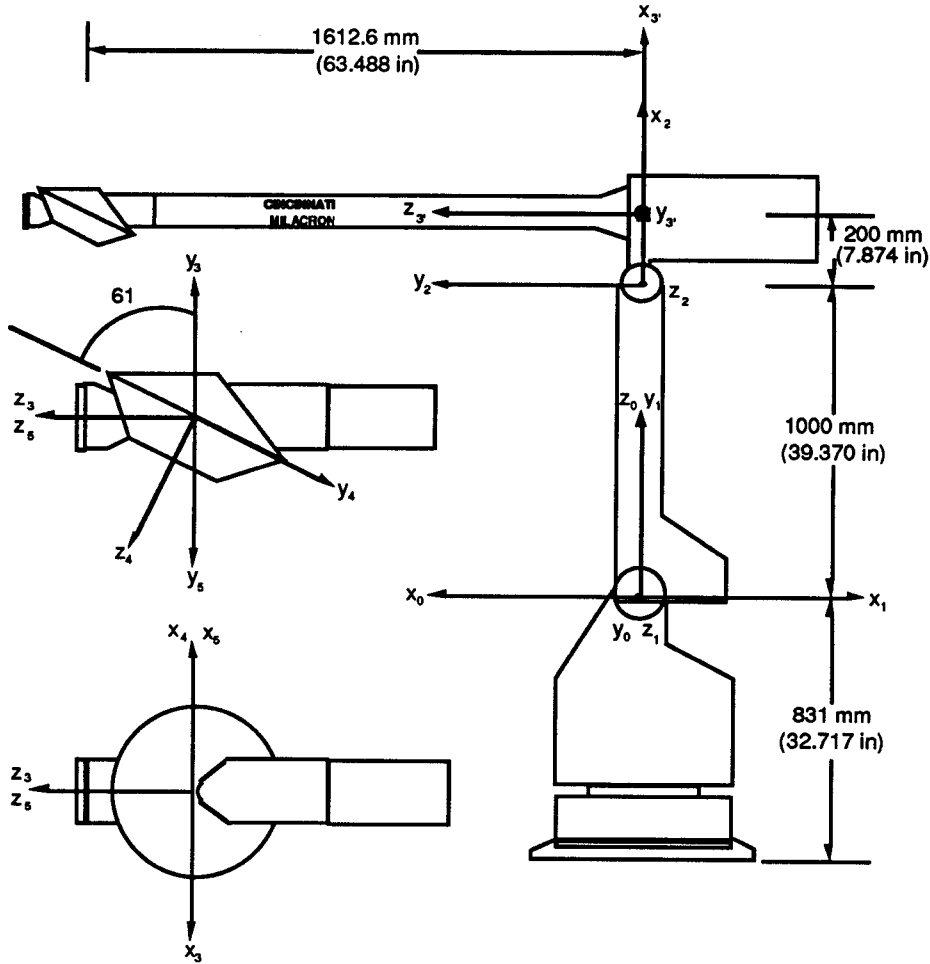

Figure 3: Coordinate frames using the Denavit-Hartenberg notation, robot is shown in zero or home position

2.4 Denavit-Hartenberg Parameters for T³-646

Table 1: Denavit-Hartenberg parameters for the ADACS robot

| Link Number | θ_i | d_i | a_i | α_i |
|-------------|------------------------|--------|-------|-------------|
| 1 | $\theta_1 + 180^\circ$ | 0 | 0 | 90° |
| 2 | $\theta_2 + 90^\circ$ | 0 | 1000 | 0 |
| 3' | θ_3 | 0 | 200 | -90° |
| 3 | -90° | 1612.6 | 0 | 0 |
| 4 | $\theta_4 + 180^\circ$ | 0 | 0 | -61° |
| 5 | θ_5 | 0 | 0 | 61° |
| 6 | θ_6 | 0 | 0 | 0 |

2.5 Transformation Matrixes for T³-646

After the Denavit-Hartenberg parameters have been determined for each link of the robot, a matrix for each link can be constructed to represent the position and orientation of frame i relative to frame $i - 1$. The general matrix is shown below.

$$T_{i-1}^i = \begin{bmatrix} \cos \theta_i & -\sin \theta_i \cos \alpha_i & \sin \theta_i \sin \alpha_i & a_i \cos \theta_i \\ \sin \theta_i & \cos \theta_i \cos \alpha_i & -\cos \theta_i \sin \alpha_i & a_i \sin \theta_i \\ 0 & \sin \alpha_i & \cos \alpha_i & d_i \\ 0 & 0 & 0 & 1 \end{bmatrix}$$

Substitution of the parameters for each link into this matrix produces a 4 x 4 matrix for each link of the robot. The first three 3 x 1 column vectors of the matrix contain the direction cosines of the coordinate axis of frame i , while the last 3 x 1 column vector contains the position of the origin O_i . The matrix for each link of the robot is shown below.

$$T_1^0 = \begin{bmatrix} -\cos \theta_1 & 0 & -\sin \theta_1 & 0 \\ -\sin \theta_1 & 0 & \cos \theta_1 & 0 \\ 0 & 1 & 0 & 0 \\ 0 & 0 & 0 & 1 \end{bmatrix}$$

$$T_4^3 = \begin{bmatrix} -\cos \theta_4 & \sin \theta_4 \cos (-61) & -\sin \theta_4 \sin (-61) & 0 \\ -\sin \theta_4 & -\cos \theta_4 \cos (-61) & \cos \theta_4 \sin (-61) & 0 \\ 0 & \sin (-61) & \cos (-61) & 0 \\ 0 & 0 & 0 & 1 \end{bmatrix}$$

$$T_2^1 = \begin{bmatrix} \cos (\theta_2 + 90) & -\sin (\theta_2 + 90) & 0 & 1000 \cos (\theta_2 + 90) \\ \sin (\theta_2 + 90) & \cos (\theta_2 + 90) & 0 & 1000 \sin (\theta_2 + 90) \\ 0 & 0 & 1 & 0 \\ 0 & 0 & 0 & 1 \end{bmatrix}$$

$$T_5^4 = \begin{bmatrix} \cos \theta_5 & -\sin \theta_5 \cos (61) & \sin \theta_5 \sin (61) & 0 \\ \sin \theta_5 & \cos \theta_5 \cos (61) & -\cos \theta_5 \sin (61) & 0 \\ 0 & \sin (61) & \cos (61) & 0 \\ 0 & 0 & 0 & 1 \end{bmatrix}$$

$$T_3^2 = \begin{bmatrix} \cos \theta_3 & 0 & -\sin \theta_3 & 200 \cos \theta_3 \\ \sin \theta_3 & 0 & \cos \theta_3 & 200 \sin \theta_3 \\ 0 & -1 & 0 & 0 \\ 0 & 0 & 0 & 1 \end{bmatrix}$$

$$T_6^5 = \begin{bmatrix} \cos \theta_6 & -\sin \theta_6 & 0 & 0 \\ \sin \theta_6 & \cos \theta_6 & 0 & 0 \\ 0 & 0 & 1 & 0 \\ 0 & 0 & 0 & 1 \end{bmatrix}$$

$$T_3^3 = \begin{bmatrix} 0 & 1 & 0 & 0 \\ -1 & 0 & 0 & 0 \\ 0 & 0 & 1 & 1612.6 \\ 0 & 0 & 0 & 1 \end{bmatrix}$$

NOTES:

- * $\cos (\theta + 180) = -\cos \theta$
- * $\sin (\theta + 180) = -\sin \theta$

To ease in the transformation from frame 2 to 3, an additional frame was added to the robot. This frame is labeled 3' and is rigidly attached to the arm of the robot. The transformation from frame 2 to frame 3' takes into account the rotation of the arm about the joint axis of frame 2 and the translation along the X axis of frame 2, a_1 in the Denavit-Hartenberg parameters. The transformation from frame 3' to frame 3 is a translation along the Z axis of frame 3', this is d_1 in the Denavit-Hartenberg parameters.

2.6 Kinematic Model for T³-646

After the matrices have been determined for each link, we wish to determine the relationship between the position and orientation of the last frame with respect to the base frame of the robot. The manipulator arm consists of n+1 links from the base to the tip of the end-effector, in which relative position and orientation of adjacent links are represented by the 4 x 4 matrices developed using the Denavit-Hartenberg parameters. If n consecutive coordinate transformations are made along the manipulator serial linkage, we can derive the end-effector location and orientation with respect to the base frame. In the case of the T³-646, there are 6 revolute joints to transform. Therefore, the following equation can be derived

$$T_6^0 = T_1^0 T_2^1 T_3^2 T_3'^3 T_4^3 T_5^4 T_6^5$$

where T_6^0 is a 4 x 4 matrix representation of the position and orientation of the last frame with respect to the base frame. This equation is referred to as the kinematic equation of the manipulator arm and governs the fundamental kinematic behavior of the arm.

$$T_6^0 = \begin{bmatrix} r_{11} & r_{12} & r_{13} & P_x \\ r_{21} & r_{22} & r_{23} & P_y \\ r_{31} & r_{32} & r_{33} & P_z \\ 0 & 0 & 0 & 1 \end{bmatrix}$$

$$\begin{bmatrix} r_{11} & r_{12} & r_{13} \\ r_{21} & r_{22} & r_{23} \\ r_{31} & r_{32} & r_{33} \end{bmatrix}$$

Orientation matrix of the end-effector with respect to the base coordinate frame

$$\begin{bmatrix} P_x \\ P_y \\ P_z \end{bmatrix}$$

Position of the end-effector with respect to the base coordinate frame

It should be noted that there are several exceptions to the Denavit-Hartenberg notation rule. For the base and last link, there is no common normal since each of these links has only one joint axis. Therefore, the coordinate frames are defined as follows. For the base link, the origin of the coordinate frame can be chosen arbitrarily on joint axis 1. The Z_0 axis must be parallel to the joint axis, but the orientation of the X and Y axes about the joint is arbitrary. For the last link, the origin of the coordinate frame can be chosen at any convenient point of the end-effector, however the X axis must intersect the last joint axis at a right angle.

3 INVERSE KINEMATIC MODEL

3.1 Inverse Kinematics

The kinematic model derived in the previous section describes the relationship between the given joint displacements and the resultant end-effector position and orientation. Finding the end-effector position and orientation from a given set of joint values is known as a direct kinematic problem. Finding the joint displacements for a given end-effector position and orientation is known as an inverse kinematic problem.

Solving the inverse kinematic problem provides a model which allows the end-effector motion to be described in terms of the joint value motion. This is necessary for a joint-angle robot controller interface.

When solving the direct kinematic model, there is one unique end-effector position and orientation for a given set of joint angles. The inverse kinematic problem, on the other hand, is more complex because multiple solutions can exist for a given end-effector position and orientation. It is also possible that no solutions exist for a particular range of end-effector locations. Further, since the inverse kinematic equations consist of nonlinear simultaneous equations involving many trigonometric functions, a closed-form solution is not always possible to derive. In this case the joint displacements are calculated using numerical methods. Fortunately, a closed form solution can be derived for the T³-646.

3.2 Geometric Solution for Joints 1, 2 and 3

As stated before, the T³-646 is a six degree of freedom robot with a three roll wrist. This configuration allows the determination of the first three joints to be solved using a geometric model.

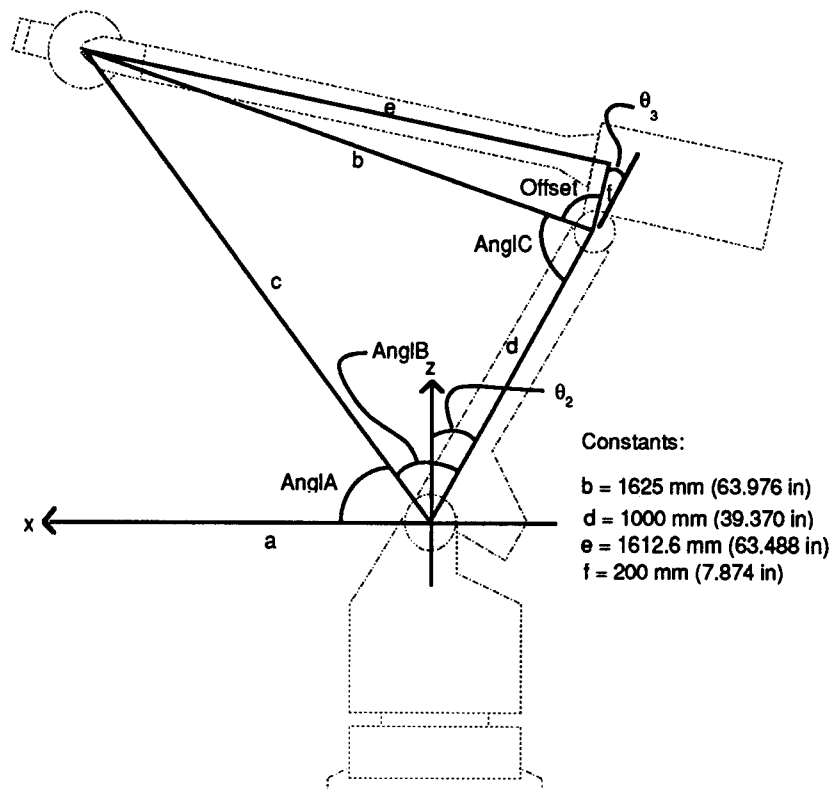

Figure 4: Geometric Solution for Joints 1, 2, and 3

Figure 4 shows the how the first three (1, 2, and 3) joint angles can be determined for a given position of the manipulator. The center of the wrist is considered to be the end-effector, the last section can be considered part of the tool transformation.

The geometry is shown again in Figure 5 without the outline of the robot to simplify the drawing for the calculations of the joint values.

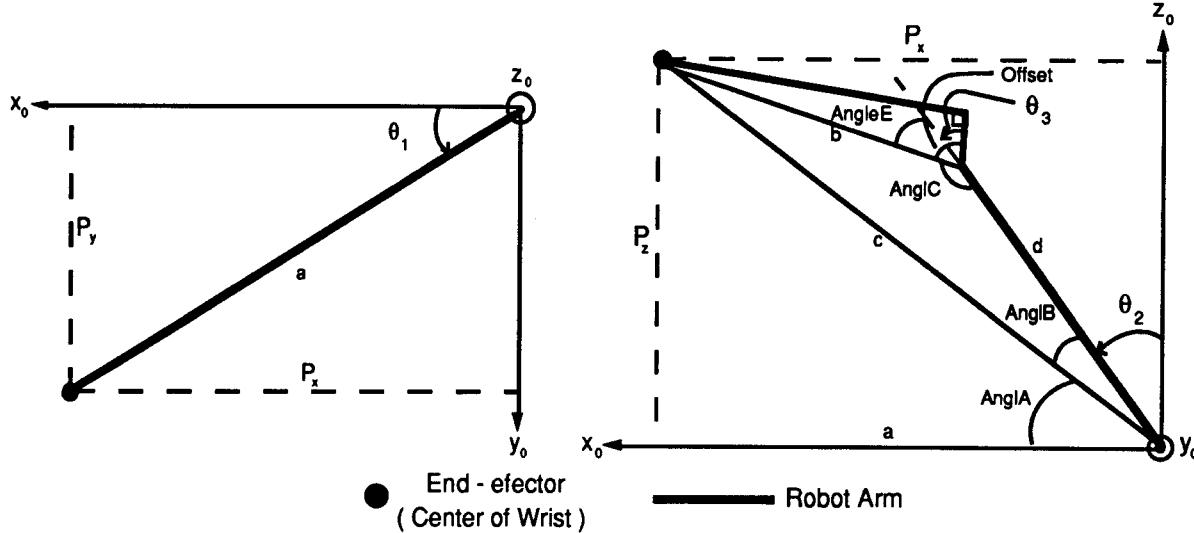

Figure 5: Geometric solution for Joints 1, 2, and 3

3.2.1 Solution for Joint 1

The solution for joint 1 can be determined by examining the projection of the manipulator arm in the x-y plane (left side of Figure 5). The length of projection a can be determined to be:

$$a = (p_x^2 + p_y^2)^{\frac{1}{2}}$$

where p_x is the length of the projection in the x-plane (or the x position of the end-effector relative to the base coordinate frame), and p_y is the length of the projection in the y-plane (or the y position of the end-effector relative to the base coordinated frame). θ_1 can then be determined using the inverse tangent function as follows:

$$\theta_1 = \text{Atan2}(p_x, p_y) = \text{Atan2}\left(\frac{p_y}{p_x}\right)$$

3.2.2 Solution for Joint 2

Examining the right section of Figure 5 it can be determined that

$$\text{AnglA} + \text{AnglB} + \theta_2 = 90^\circ$$

therefore:

$$\theta_2 = 90^\circ - \text{AnglB} - \text{AnglA}$$

To solve this equation, AnglA and AnglB must be determined. AnglA is defined as the angle made between the line segment c and the x axis of the base coordinate system. Segment c is defined as:

$$c = (p_x^2 + p_y^2 + p_z^2)^{\frac{1}{2}}$$

Where p_x position of the end-effector in the x axis of the base coordinate system, p_y the position of the end-effector in the y axis of the base coordinate system, and p_z is the position the end-effector in the z axis of the base coordinate system. $AnglA$ can then be determined using the inverse tangent function and is derived as follows:

$$AnglA = \tan^{-1} \frac{p_z}{a} = \tan^{-1} \left(\frac{p_z}{(p_x^2 + p_y^2)^{\frac{1}{2}}} \right)$$

$AnglB$ can be determined using the Law of Cosines on triangle bcd. Using the Law of Cosines it can be determined that

$$b^2 = c^2 + d^2 - 2cd \cos(AnglB)$$

therefore:

$$AnglB = \cos^{-1} \left(\frac{b^2 - c^2 - d^2}{2cd} \right)$$

Once $AnglA$ and $AnglB$ have been determined, θ_2 is calculated.

$$\theta_2 = 90^\circ - AnglB - AnglA$$

3.2.3 Solution for Joint 3

The solution for joint 3 is a little more complicated than the solutions for joints 1 and 2. Examine the right section of Figure 5. It can be seen that the Offset angle is always a constant and can be evaluated using the inverse tangent function.

$$\text{Offset} = \tan^{-1} \frac{1612.6 \text{ mm}}{200 \text{ mm}} = 82.930^\circ$$

It can also be seen that $AngleE$ is always the sum of the Offset angle and θ_3 (NOTE: θ_3 is negative in the right section of Figure 5). Therefore

$$\theta_3 = AngleE - \text{Offset}$$

$AngleE$ is defined as the angle between line segment b and the extension of line segment d. Upon further inspection it can be determined that $AngleE$ and $AngleC$ are supplementary angles, therefore

$$AngleE = 180^\circ - AngleC$$

This leads to another problem, $AngleC$ must be solved for. Using the Law of Cosines on triangle bcd again, it can be determined that

$$c^2 = b^2 + d^2 - 2bd \cos(AngleC)$$

therefore:

$$AngleC = \cos^{-1} \left(\frac{c^2 - b^2 - d^2}{2bd} \right)$$

θ_3 can then be determined using the formula

$$\theta_3 = AngleE - \text{Offset}$$

Therefore it has been determined that the angular positions for the first three joints can be determined based entirely on the position of the end-effector in the x axis of the base coordinate frame, p_x , the position of the end-effector in the y axis of the base coordinate frame, p_y , and the position of the end-effector in the z axis of the base coordinate frame, p_z .

3.3 Solution for Joints 4, 5, and 6

In the previous section, the displacements for the first three joints were solved for geometrically. The derivation of the last three joints is a much more involved algebraic and trigonometric problem. There exists two specific problems to be dealt with. The first problem is the presence of a singularity point. A singularity point occurs when two or more joint axes line up causing an infinite number of possible solutions for any given orientation. A singularity point occurs in this manipulator when links 4 and 6 line up, or when the value of joint 5 is zero. There is also an ambiguity in the wrist. There are two solutions for the last three joints for a given orientation. This ambiguity will be referred to as “wrist-flip” and “wrist-no-flip.”

3.3.1 Rotation Matrixes

In determining the values of the last three joints, only the rotation part of the transformation matrix is necessary (there are no position changes in the last three links, just orientation changes). The rotation matrixes for the links are shown below.

NOTE: From here to the end of the paper, the term $(\theta_2 + 90)$ will be abbreviated as θ_2 , therefore, when θ_2 occurs in a matrix or an equation, the value $(\theta_2 + 90)$ must be placed there. For example, $\cos \theta_2$ MUST be replaced with the value $\cos (\theta_2 + 90)$. This abbreviation is necessary to simplify the complex equations to follow.

$$\begin{aligned}
 R_1^0 &= \begin{bmatrix} -\cos \theta_1 & 0 & -\sin \theta_1 \\ -\sin \theta_1 & 0 & \cos \theta_1 \\ 0 & 1 & 0 \end{bmatrix} & R_4^3 &= \begin{bmatrix} -\cos \theta_4 & \sin \theta_4 \cos (-61) & -\sin \theta_4 \sin (-61) \\ -\sin \theta_4 & -\cos \theta_4 \cos (-61) & \cos \theta_4 \sin (-61) \\ 0 & \sin (-61) & \cos (-61) \end{bmatrix} \\
 R_2^1 &= \begin{bmatrix} \cos \theta_2 & -\sin \theta_2 & 0 \\ \sin \theta_2 & \cos \theta_2 & 0 \\ 0 & 0 & 1 \end{bmatrix} & R_5^4 &= \begin{bmatrix} \cos \theta_5 & -\sin \theta_5 \cos (61) & \sin \theta_5 \sin (61) \\ \sin \theta_5 & \cos \theta_5 \cos (61) & -\cos \theta_5 \sin (61) \\ 0 & \sin (61) & \cos (61) \end{bmatrix} \\
 R_3^2 &= \begin{bmatrix} \cos \theta_3 & 0 & -\sin \theta_3 \\ \sin \theta_3 & 0 & \cos \theta_3 \\ 0 & -1 & 0 \end{bmatrix} & R_6^5 &= \begin{bmatrix} \cos \theta_6 & -\sin \theta_6 & 0 \\ \sin \theta_6 & \cos \theta_6 & 0 \\ 0 & 0 & 1 \end{bmatrix} \\
 R_3^3 &= \begin{bmatrix} 0 & 1 & 0 \\ -1 & 0 & 0 \\ 0 & 0 & 1 \end{bmatrix}
 \end{aligned}$$

Once the values are known for joints 1, 2, and 3, these values can be substituted back into the kinematic model to derive the last three joint values. Looking back at the rotation section of the kinematic model, it can be seen that the orientation of the last frame with respect to the base frame is $R_6^0 = R_1^0 R_2^1 R_3^2 R_3^3 R_4^3 R_5^4 R_6^5$. If we substitute the values of θ_1 , θ_2 , and θ_3 back into $R_1^0 R_2^1 R_3^2 R_3^3$, this rotation matrix gives the orientation of frame 3 with respect to the base frame as a numerical matrix. If this numerical matrix is inverted and premultiplied to R_6^0 , we can obtain the numerical rotation matrix of the last frame with respect to frame 3, R_6^3 . The symbolic rotation matrix of the last frame with respect to frame 3 can be obtained by multiplying the rotation matrixes of the the last three links, $R_6^3 = R_4^3 R_5^4 R_6^5$. We now have the symbolic and numerical rotation matrix of the last frame with respect to frame 3. The equations are shown again below.

$$\begin{aligned}
 R_6^3 &= R_4^3 R_5^4 R_6^5 && \text{Symbolically} \\
 R_6^3 &= (R_1^0 R_2^1 R_3^2 R_3^3)^{-1} R_6^0 && \text{Numerically}
 \end{aligned}$$

When the rotation matrixes are multiplied together the following is obtained. **NOTE:** Due to the complexity of the following calculations, it is recommended that the matrix multiplication be performed with a software package such as Mathematica. The terms COS and SIN have been abbreviated to c and s respectively.

$$R_6^3 = R_4^3 R_5^4 R_6^5 \quad R_6^3 = (R_1^0 R_2^1 R_3^2 R_3^{3-1}) R_6^0$$

$$R_6^3 = \begin{bmatrix} r_{11} & r_{12} & r_{13} \\ r_{21} & r_{22} & r_{23} \\ r_{31} & r_{32} & r_{33} \end{bmatrix} \quad R_6^3 = \begin{bmatrix} a & b & c \\ d & e & f \\ g & h & i \end{bmatrix}$$

Symbolically Numerically

$$r_{11} = C_6(-C_4 C_5 + C(-61) S_4 S_5) + S_6(C_5 C(-61) C(61) S_4 + C_4 C(61) S_5 - S_4 S(61) S(-61)) = a$$

$$r_{12} = S_6(C_4 C_5 - C(-61) S_4 S_5) + C_6(C_5 C(61) C(-61) S_4 + C_4 C(61) S_5 - S_4 S(61) S(-61)) = b$$

$$r_{13} = -C_5 S_4 C(-61) S(61) - C_4 S_5 S(61) - C(61) S(-61) S_4 = c$$

$$r_{21} = C_6(-C_5 S_4 - C_4 S_5 C(-61)) + S_6(-C_4 C_5 C(61) C(-61) + S_4 S_5 C(61) + C_4 S(61) S(-61)) = d$$

$$r_{22} = S_6(C_5 S_4 + C_4 S_5 C(-61)) + C_6(S_4 S_5 C(61) - C_4 C_5 C(61) C(-61) + C_4 S(61) S(-61)) = e$$

$$r_{23} = C_4 C_5 C(-61) S(61) - S_4 S_5 S(61) + C_4 C(61) S(-61) = f$$

$$r_{31} = C_6 S_5 S(-61) + S_6(C(-61) S(61) + C_5 C(61) S(-61)) = g$$

$$r_{32} = C_6(C(-61) S(61) + C_5 C(61) S(-61)) - S_5 S_6 S(-61) = h$$

$$r_{33} = C(61) C(-61) - C_5 S(61) S(-61) = i$$

3.3.2 Singularity Point

As stated before, a singularity occurs in the manipulator when θ_5 is equal to 0. When the above rotation matrix is examined, it can be seen that the r_{33} value is only dependent on the value of θ_5 .

$$r_{33} = C(61) C(-61) - C_5 S(61) S(-61) = i$$

Therefore, we must determine the value of i when θ_5 is equal to 0. The value of $\text{Cos}(0)$ is 1, therefore, the manipulator is in a singular position when

$$r_{33} = C(61) C(-61) - S(61) S(-61)$$

$$r_{33} = 0.23504 - (-0.76496) = 1 = i$$

Therefore, a singularity occurs when the value of i , in the numerical rotation matrix, is equal to 1. When a singularity occurs, the value of θ_5 is set to 0, the value of θ_4 is set to its previous value, and joint 6 is determined and actuated to the proper orientation. **NOTE:** In the control program, the value i must be checked before each calculation to determine if a singularity occurs. If a singularity occurs and the value of θ_4 is not set to its previous position, the inverse kinematic model will explode.

3.3.3 Solution for Joint 6

The most complex part of the solution for the last three joints is determining the value of one of the three joints. This is accomplished by examining the symbolic rotation matrix for equations that can be used to eliminate all the variables except the one you are looking for and to combine the remaining variables into a tangent function. There is no real method to go about this except experience in knowing what to look for and trial and error.

The first step to help clean up the matrix components is to evaluate all the cosines and sines of 61 and -61 degrees found in the equations. These cleaned up equations are shown below.

$$r_{11} = c_6(-c_4 c_5 + 0.48481 s_4 s_5) + s_6(0.23504 c_5 s_4 + 0.48481 c_4 s_5 + 0.76496 s_4) = a$$

$$r_{12} = c_6(0.23564 c_5 s_4 + 0.48481 c_4 s_5 + 0.76496 s_4) + s_6(-c_4 c_5 + 0.48481 s_4 s_5) = b$$

$$r_{13} = 0.424024 s_4 (1 - c_5) - 0.87462 c_4 s_5 = c$$

$$r_{21} = c_6(-c_5 s_4 - c_4 s_5 c(-61)) + s_6(-c_4 c_5 c(61) c(-61) + s_4 s_5 c(61) + c_4 s(61) s(-61)) = d$$

$$r_{22} = s_6(c_5 s_4 + 0.48481 c_4 s_5) + c_6(0.48481 s_4 s_5 - 0.23504 c_4 c_5 - 0.76496 c_4) = e$$

$$r_{23} = 0.424024 c_4 (c_5 - 1) - 0.87462 s_4 s_5 = f$$

$$r_{31} = -0.87462 c_6 s_5 + 0.424024 s_6 (1 - c_5) = g$$

$$r_{32} = 0.424024 c_6 (1 - c_5) + 0.87462 s_5 s_6 = h$$

$$r_{33} = 0.23504 + 0.76496 c_5 = i$$

Compare the g and h terms in each matrix

$$r_{31} = -0.87462 c_6 s_5 + 0.424024 s_6 (1 - c_5) = g$$

$$r_{32} = 0.87462 s_5 s_6 + 0.424024 c_6 (1 - c_5) = h$$

Multiply the top equation by s_6

Multiply the bottom equation by c_6

Then add the equations

$$s_6 g = -0.87462 c_6 s_5 s_6 + 0.424024 s_6^2 (1 - c_5)$$

$$c_6 h = 0.87462 s_5 s_6 c_6 + 0.424024 c_6^2 (1 - c_5)$$

$$s_6 g + c_6 h = 0.424024(1 - c_5)(s_6^2 + c_6^2)$$

$$s_6 g + c_6 h = 0.424024(1 - c_5)$$

$$s_6^2 + c_6^2 = 1$$

Eq. 1

We can now make a substitution for c_5

Compare the i terms in each matrix

$$i = 0.23504 + 0.76496 c_5$$

$$c_5 = (i - 0.23504)/0.76496$$

Therefore

Substituting this into **Eq. 1**, we obtain the following

$$s_6 g + c_6 h = 0.424024(1 - (i - 0.23504)/0.76496) \quad \text{Eq. 2}$$

To continue, some trigonometric substitutions must be employed.

$$\cos \theta = \frac{1 - \tan^2 \frac{\theta}{2}}{1 + \tan^2 \frac{\theta}{2}} \quad \sin \theta = \frac{2 \tan \frac{\theta}{2}}{1 + \tan^2 \frac{\theta}{2}}$$

And to ease in the notation, the following substitution is made

$$\tan \frac{\theta}{2} = K \quad \tan \frac{\theta_6}{2} = K_6$$

Making these substitutions into **Eq. 2**, we obtain

$$\left(\frac{2 K_6}{1 + K_6^2} \right) g + \left(\frac{1 - K_6^2}{1 + K_6^2} \right) h = 0.424024 \left(1 - \frac{i - 0.23504}{0.76496} \right) \quad \text{Eq. 3}$$

Substituting n for the right side of **Eq. 3**

$$n = 0.424024 \left(1 - \frac{i - 0.23504}{0.76496} \right)$$

We obtain

$$\left(\frac{2 K_6}{1 + K_6^2} \right) g + \left(\frac{1 - K_6^2}{1 + K_6^2} \right) h = n$$

Multiplying both sides of the equation by $(1 + K_6^2)$

$$2 K_6 g + (1 - K_6^2) h = n(1 + K_6^2)$$

Multiplying the h and n through the parentheses

$$2 K_6 g + h - h K_6^2 = n + n K_6^2 \quad \text{Eq. 4}$$

Rearranging **Eq. 4**

$$(h + n) K_6^2 - (2g) K_6 + (n - h) = 0 \quad \text{Eq. 5}$$

Upon examining **Eq. 5**, it can be seen that it is a quadratic equation of the form

$$a x^2 + b x + c = 0$$

Where:

$$\begin{aligned} a &= (h + n) \\ b &= -2g \\ c &= (n - h) \\ x &= K_6 \end{aligned}$$

The roots of a quadratic equation are

$$\frac{-b \pm \sqrt{b^2 - 4ac}}{2a}$$

Making the substitutions into this equation and solving for the roots, the following is obtained

$$\frac{g \pm \sqrt{g^2 + h^2 - n^2}}{(h + n)} \quad \text{Eq. 6}$$

Therefore, from Eq. 6, the roots are

$$K_{\theta_6_1} = \frac{g + \sqrt{g^2 + h^2 - n^2}}{(h + n)} \quad K_{\theta_6_2} = \frac{g - \sqrt{g^2 + h^2 - n^2}}{(h + n)}$$

Remembering the substitution

$$\tan \frac{\theta_6}{2} = K_6$$

Therefore

$$\theta_6 = 2 \tan^{-1} K_6$$

Because there are two possible roots, there are two possible solutions for θ_6 .

$$\theta_{6_1} = 2 \tan^{-1} K_{\theta_6_1}$$

$$\theta_{6_2} = 2 \tan^{-1} K_{\theta_6_2}$$

Making the final substitution for K back into these equations, the two solutions for θ_6 are obtained.

$$\theta_{6_1} = 2 \tan^{-1} \left(\frac{g + \sqrt{g^2 + h^2 - n^2}}{(h + n)} \right) \quad \theta_{6_2} = 2 \tan^{-1} \left(\frac{g - \sqrt{g^2 + h^2 - n^2}}{(h + n)} \right)$$

The two possible solutions for θ_6 causes the ambiguity in the wrist. There are two possible solution sets for $\{\theta_4, \theta_5, \theta_6\}$ that give the required orientation for the end-effector. These sets are found by backing out θ_5 and θ_4 using both solutions for θ_6 . A set is determined using the first solution of θ_6 and a second set is determined using the second solution of θ_6 . The set that requires the least amount of movement is then sent to the controller.

3.3.4 Solution for Joint 5

After θ_6 has been determined, its value is substituted back into its rotation matrix.

$$R_6^5 = \begin{bmatrix} \cos \theta_6 & -\sin \theta_6 & 0 \\ \sin \theta_6 & \cos \theta_6 & 0 \\ 0 & 0 & 1 \end{bmatrix}$$

Therefore, this matrix has a numerical value. This matrix is then inverted and post multiplied to the rotation matrix that gives the orientation of the last frame with respect to the third frame.

$$R_6^3 R_6^{5^{-1}} = R_6^3 R_5^6 = R_5^3 \quad \text{Numerically}$$

$$R_5^3 = R_4^3 R_5^4 \quad \text{Symbolically}$$

$$R_5^3 = R_4^3 R_5^4 \quad R_5^3 = R_6^3 R_6^{5-1} = R_6^3 R_5^6$$

$$R_5^3 = \begin{bmatrix} r_{11} & r_{12} & r_{13} \\ r_{21} & r_{22} & r_{23} \\ r_{31} & r_{32} & r_{33} \end{bmatrix} \quad R_5^3 = \begin{bmatrix} a & b & c \\ d & e & f \\ g & h & i \end{bmatrix}$$

Symbolically Numerically

$$r_{11} = -c_4 c_5 + 0.48481 s_4 s_5 = a$$

$$r_{12} = 0.76496 s_4 + 0.23504 c_5 s_4 + 0.48481 c_4 s_5 = b$$

$$r_{13} = 0.424024 s_4 (1 - c_5) - 0.87462 c_4 s_5 = c$$

$$r_{21} = -s_4 c_5 - 0.48481 c_4 s_5 = d$$

$$r_{22} = -0.76496 c_4 - 0.23504 c_4 c_5 + 0.48481 s_4 s_5 = e$$

$$r_{23} = 0.424024 c_4 (c_5 - 1) - 0.87462 s_4 s_5 = f$$

$$r_{31} = -0.87462 s_5 = g$$

$$r_{32} = 0.424024 - 0.424024 c_5 = h$$

$$r_{33} = 0.23504 + 0.76496 c_5 = i$$

Comparing the g and h terms of each matrix, it can be seen that a tangent function can be formed rather easily.

$$\tan \theta_5 = \frac{\sin \theta_5}{\cos \theta_5}$$

$$r_{31} = -0.87462 s_5 = g$$

$$r_{32} = 0.424024 - 0.424024 c_5 = h$$

Solving for s_5 and c_5 we obtain

$$\sin \theta_5 = -\left(\frac{g}{0.87462}\right) \quad \cos \theta_5 = -\left(\frac{h - 0.424024}{0.424024}\right)$$

Combining the Sin and Cos functions, θ_5 can be solved.

$$\theta_5 = \tan^{-1} \left(\frac{\frac{-g}{0.87462}}{-\left(\frac{h - 0.424024}{0.424024}\right)} \right)$$

There are two solutions for θ_5 . One is determined using the first solution for θ_6 , and a second is determined using the second solution for θ_6 . These solutions MUST be kept in their respective sets. DO NOT combine them into one set or mix the sets. Incorrect joint angles will be calculated if this is not followed.

3.3.5 Solution for Joint 4

After the value for θ_5 has been calculated, it is substituted back into its rotation matrix.

$$R_5^4 = \begin{bmatrix} \cos \theta_5 & -\sin \theta_5 \cos(61) & \sin \theta_5 \sin(61) \\ \sin \theta_5 & \cos \theta_5 \cos(61) & -\cos \theta_5 \sin(61) \\ 0 & \sin(61) & \cos(61) \end{bmatrix}$$

Therefore, this matrix has a numerical value. This matrix is then inverted and post multiplied to the rotation matrix that gives the orientation of the fifth frame with respect to the third frame.

$$R_4^3 = R_5^3 R_5^4^{-1} = R_5^3 R_4^5$$

$$R_4^3 = R_4^3$$

| | |
|--|---|
| $R_4^3 = \begin{bmatrix} r_{11} & r_{12} & r_{13} \\ r_{21} & r_{22} & r_{23} \\ r_{31} & r_{32} & r_{33} \end{bmatrix}$ <p style="text-align: center;">Symbolically</p> | <p>Numerically</p> $R_4^3 = \begin{bmatrix} a & b & c \\ d & e & f \\ g & h & i \end{bmatrix}$ <p>Numerically</p> |
|--|---|

$$r_{11} = -c_4 = a$$

$$r_{12} = c(-61) s_4 = b$$

$$r_{13} = -s(-61) s_4 = c$$

$$r_{21} = -s_4 = d$$

$$r_{22} = -c(-61) c_4 = e$$

$$r_{23} = s(-61) c_4 = f$$

$$r_{31} = 0$$

$$r_{32} = s(-61)$$

$$r_{33} = c(-61)$$

Upon inspection of the rotation matrix, it can be seen that a tangent function can easily be created by using the a and d terms of each matrix.

$$r_{11} = -c_4 = a$$

$$r_{21} = -s_4 = d$$

$$\tan \theta_4 = \frac{\sin \theta_4}{\cos \theta_4}$$

$$\theta_4 = \tan^{-1} \left(\frac{-d}{-a} \right)$$

Once again, there are two solutions for θ_4 . One is determined using the first solution for θ_6 , and a second is determined using the second solution for θ_6 . These solutions MUST be kept in their respective sets. DO NOT combine them into one set or mix the sets. Incorrect joint angles will be calculated if this is not followed.

After θ_4 has been calculated for each solution for θ_6 , there are two complete sets of joint angles for the given position and orientation. θ_1 , θ_2 , and θ_3 will be the same for each set. The two sets, labeled "wrist-flip" and "wrist-no-flip", are then compared with the previous angles of the manipulator and the set with the closest to this is sent to the robot controller and the joints are actuated to the calculated value.

4 ALTERNATIVE KINEMATIC MODEL

4.1 Link Transform Approach

The link transform approach assigns a coordinate frame to each link of the robot. The coordinate frame is placed at the joint of the link with the joint revolving around the Z axis in a right-hand sense. After a coordinate frame has been assigned to the base of the robot and to each link of the robot, a kinematic equation can be developed to relate the position and orientation of the last frame (the end-effector) to the base frame. Figure 6 below shows the frames that were assigned to the robot for the link transform approach.

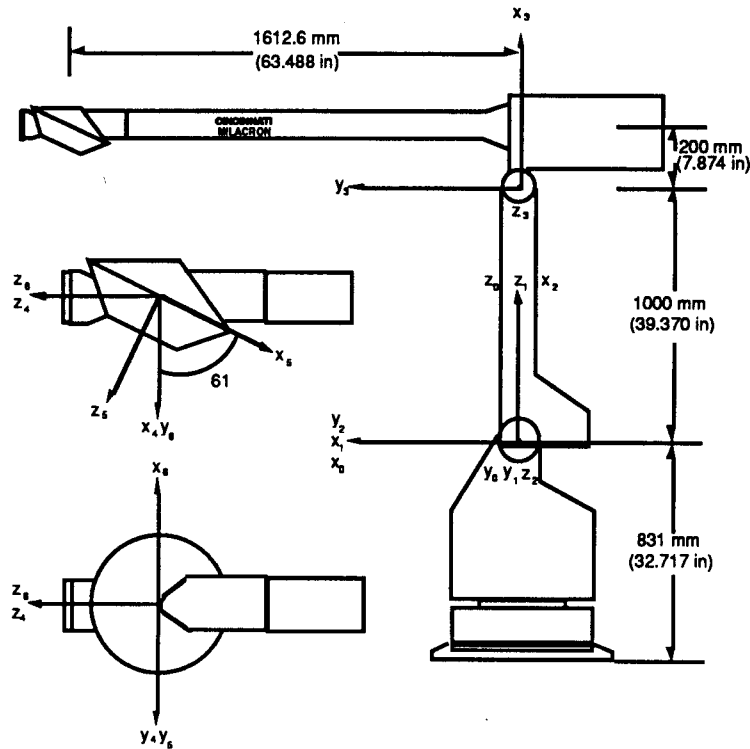

Figure 6: Frames assigned to each link using the Link Transform Approach, robot shown in zero or home position

A transformation matrix can be calculated for each link by comparing the relative motion of a frame with respect to its previous frame. As a joint is rotated, the frame of the corresponding link also moves by a certain amount relative to the previous frame. An example of this is shown in Figure 7.

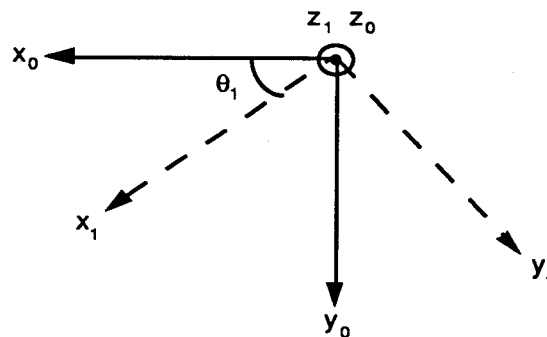

Figure 7: Relative motion of frame 1 with respect to frame 0

From Figure 7, the transformation matrix that relates the motion of frame 1 with respect to frame 0 can be derived. The following is how this transformation matrix is derived. As link 1 (and frame 1) revolves with respect to link 0 (and frame 0) in a positive direction, the following happens:

The x_1 axis varies from 1 @ 0 degrees to 0 @ 90 degrees on the x_0 axis. This motion is defined by the cosine of joint angle 1.

The x_1 axis varies from 0 @ 0 degrees to 1 @ 90 degrees on the y_0 axis. This motion is defined by the sine of joint angle 1.

The x_1 axis is always 0 on the z_0 axis because it always remains perpendicular to it.

The y_1 axis varies from 0 @ 0 degrees to -1 @ 90 degrees on the x_0 axis. This motion is defined by the -sine of joint angle 1.

The y_1 axis varies from 1 @ 0 degrees to 0 @ 90 degrees on the y_0 axis. This motion is defined by the cosine of joint angle 1.

The y_1 axis is always 0 on the z_0 axis because of its perpendicularity.

The z_1 axis remains coincident with the z_0 axis during all motion.

p_x = Distance along the x_{i-1} axis from frame $i-1$ to frame $i = 0$

p_y = Distance along the y_{i-1} axis from frame $i-1$ to frame $i = 0$

p_z = Distance along the z_{i-1} axis from frame $i-1$ to frame $i = 0$

From this information, a transform matrix can be assembled. This is a 4 x 4 matrix with the bottom row comprised of fillers {0, 0, 0, 1} that do not effect the output of the matrix.

$$T_{i-1}^{i-1} = \begin{matrix} X_{i-1} \\ Y_{i-1} \\ Z_{i-1} \end{matrix} \begin{bmatrix} X_i & Y_i & Z_i & \\ r_{11} & r_{12} & r_{13} & p_x \\ r_{21} & r_{22} & r_{23} & p_y \\ r_{31} & r_{32} & r_{33} & p_z \\ 0 & 0 & 0 & 1 \end{bmatrix}$$

Filling in this generic matrix, the transformation matrix for the first joint ($i = 1$) is obtained.

$$T_1^0 = \begin{bmatrix} \cos \theta_1 & -\sin \theta_1 & 0 & 0 \\ \sin \theta_1 & \cos \theta_1 & 0 & 0 \\ 0 & 0 & 1 & 0 \\ 0 & 0 & 0 & 1 \end{bmatrix}$$

4.2 Transformation Matrixes

The preceding steps are performed for each joint and the following transform matrices are obtained.

$$T_1^0 = \begin{bmatrix} \cos \theta_1 & -\sin \theta_1 & 0 & 0 \\ \sin \theta_1 & \cos \theta_1 & 0 & 0 \\ 0 & 0 & 1 & 0 \\ 0 & 0 & 0 & 1 \end{bmatrix}$$

$$T_2^1 = \begin{bmatrix} \sin \theta_2 & \cos \theta_2 & 0 & 0 \\ 0 & 0 & 1 & 0 \\ \cos \theta_2 & -\sin \theta_2 & 0 & 0 \\ 0 & 0 & 0 & 1 \end{bmatrix}$$

$$T_3^2 = \begin{bmatrix} \cos \theta_3 & -\sin \theta_3 & 0 & 1000 \\ \sin \theta_3 & \cos \theta_3 & 0 & 0 \\ 0 & 0 & 1 & 0 \\ 0 & 0 & 0 & 1 \end{bmatrix}$$

$$T_4^3 = \begin{bmatrix} -\cos \theta_4 & \sin \theta_4 & 0 & 200 \\ 0 & 0 & 1 & 1612.6 \\ \sin \theta_4 & \cos \theta_4 & 0 & 0 \\ 0 & 0 & 0 & 1 \end{bmatrix}$$

$$T_5^4 = \begin{bmatrix} \cos 61 \cos \theta_5 & -\sin 61 \sin \theta_5 & \sin 61 & 0 \\ \sin \theta_5 & \cos \theta_5 & 0 & 0 \\ -\sin 61 \cos \theta_5 & \cos 61 \sin \theta_5 & \cos 61 & 0 \\ 0 & 0 & 0 & 1 \end{bmatrix}$$

$$T_6^5 = \begin{bmatrix} \cos 61 \sin \theta_6 & \cos 61 \cos \theta_6 & -\sin 61 & 0 \\ -\cos \theta_6 & \sin \theta_6 & 0 & 0 \\ \sin 61 \sin \theta_6 & \sin 61 \cos \theta_6 & \cos 61 & 0 \\ 0 & 0 & 0 & 1 \end{bmatrix}$$

4.3 Kinematic Model for T³-646

Once the link transform matrix for each link has been calculated, the kinematic equations can be solved for and the kinematic model obtained. This is performed in the same manner that the kinematic model was developed using the Denavit-Hartenberg parameters

$$T_6^0 = T_1^0 T_2^1 T_3^2 T_4^3 T_5^4 T_6^5$$

where T_6^0 is a 4 x 4 matrix representation of the position and orientation of the last frame with respect to the base frame. This equation is referred to as the kinematic equation of the manipulator arm and governs the fundamental kinematic behavior of the arm.

$$T_6^0 = \begin{bmatrix} r_{11} & r_{12} & r_{13} & p_x \\ r_{21} & r_{22} & r_{23} & p_y \\ r_{31} & r_{32} & r_{33} & p_z \\ 0 & 0 & 0 & 1 \end{bmatrix}$$

$$\begin{bmatrix} r_{11} & r_{12} & r_{13} \\ r_{21} & r_{22} & r_{23} \\ r_{31} & r_{32} & r_{33} \end{bmatrix}$$

Orientation matrix of the end-effector with respect to the base coordinate frame

$$\begin{bmatrix} p_x \\ p_y \\ p_z \end{bmatrix}$$

Position of the end-effector with respect to the base coordinate frame

NOTE: Although this method provides a kinematic model that is correct, the Denavit-Hartenberg method is preferred due to its standard frame placements that can be easily duplicated.

5. CONCLUSION

The principles used to derive the forward and inverse kinematics for the T³-646 can be applied to most modern "open loop" industrial robots. The Denavit-Hartenberg parameters provide a standard method of frame attachment for each joint of the robot. The forward kinematic model provides a mathematical model that describes the position and orientation of the last frame with respect to the base frame given a set of joint angles. The inverse kinematic model, derived from the forward kinematic model, provides a mathematical model that determines the required joint positions for a given end-effector position and orientation. Using the derived inverse kinematic model, the joint angles can be determined for each position and orientation of the end-effector, making a joint interface possible.

REFERENCES

Asada, H and Slotine, J. J. E., *Robot Analysis and Control*, John Wiley & Sons, New York, New York, 1986.

Craig, John J., *Introduction to Robotics Mechanics and Control*, Addison-Wesley Publishing Company, Reading, Massachusetts, 1986.

Kohn, Michael C., *Practical Numerical Methods: Algorithms and Programs*, Macmillan Publishing Company, New York, New York, 1987.

Murphy, Karl, N. and Proctor, Frederick, M., "An Advanced Deburring and Chamfering System", Presented at Third International Symposium on Robotics and Manufacturing, British Columbia, Canada, July 1990.

NIST-114A
(REV. 3-80)

U.S. DEPARTMENT OF COMMERCE
NATIONAL INSTITUTE OF STANDARDS AND TECHNOLOGY

BIBLIOGRAPHIC DATA SHEET

1. PUBLICATION OR REPORT NUMBER
NISTIR 4928

2. PERFORMING ORGANIZATION REPORT NUMBER

3. PUBLICATION DATE
SEPTEMBER 1992

4. TITLE AND SUBTITLE

Development of the Forward and Inverse Kinematic Models for the Advanced Deburring and Chamfering System (ADACS) Industrial Robot

5. AUTHOR(S)

Keith A. Stouffer

6. PERFORMING ORGANIZATION (IF JOINT OR OTHER THAN NIST, SEE INSTRUCTIONS)

U.S. DEPARTMENT OF COMMERCE
NATIONAL INSTITUTE OF STANDARDS AND TECHNOLOGY
GAITHERSBURG, MD 20899

7. CONTRACT/GRANT NUMBER

8. TYPE OF REPORT AND PERIOD COVERED

9. SPONSORING ORGANIZATION NAME AND COMPLETE ADDRESS (STREET, CITY, STATE, ZIP)

10. SUPPLEMENTARY NOTES

11. ABSTRACT (A 200-WORD OR LESS FACTUAL SUMMARY OF MOST SIGNIFICANT INFORMATION. IF DOCUMENT INCLUDES A SIGNIFICANT BIBLIOGRAPHY OR LITERATURE SURVEY, MENTION IT HERE.)

The kinematic model for the Advanced Deburring and Chamfering System (ADACS) robot, which determines the position and orientation of the manipulator end-effector for a given set of joint angles, is developed using the standardized Denavit-Hartenberg method as well as an alternative link transform method. The Denavit-Hartenberg notation is described and the parameters for each link are provided in table form. The transform matrix for each link is then derived using these parameters and the mathematical kinematic model is developed. The kinematic model has the form

$$T_6^0 = T_1^0 T_2^1 T_3^2 T_4^3 T_5^4 T_6^5$$

where T_6^0 is a 4 x 4 matrix representation of the position and orientation of the last frame with respect to the base frame.

The inverse kinematic model, which determines the joint value set for a given end-effector position and orientation, is developed from the kinematic model derived using the Denavit-Hartenberg method. The first three joints are solved using a geometric approach. The last three joints are solved for by algebraic and trigonometric manipulation of the rotation part of the transformation matrix.

There are two problems that are dealt with when the inverse kinematic model is solved for. One is the presence of a singularity point in the manipulator. A singularity occurs when two or more joint axes line up causing an infinite number of possible solutions for any given orientation. As the singularity is approached, excessive speed occurs in joint 4 as the wrist "rolls over." A singularity occurs when joint 5 is zero. When a singularity occurs, joint 5 is set to 0, joint 4 is set to its previous value and joint 6 is solved for. There is also an ambiguity in the wrist. There are two solutions for the last three joints for a specific orientation. This ambiguity is referred to as "wrist-flip" and "wrist-no-flip." Because of the wrist ambiguity, there are two possible joint sets for a given position and orientation. The values of joints 1, 2 and 3 are constant for both sets, while there are two possibilities for joints 4, 5 and 6.

12. KEY WORDS (6 TO 12 ENTRIES; ALPHABETICAL ORDER; CAPITALIZE ONLY PROPER NAMES; AND SEPARATE KEY WORDS BY SEMICOLONS)
ambiguities; Denvit Hartenberg parameters; forward kinematics; inverse kinematics; mathematical modeling; singularities; transformation matrices

13. AVAILABILITY

| |
|-------------------------------------|
| <input checked="" type="checkbox"/> |
| <input type="checkbox"/> |
| <input type="checkbox"/> |
| <input checked="" type="checkbox"/> |

UNLIMITED

FOR OFFICIAL DISTRIBUTION. DO NOT RELEASE TO NATIONAL TECHNICAL INFORMATION SERVICE (NTIS).

ORDER FROM SUPERINTENDENT OF DOCUMENTS, U.S. GOVERNMENT PRINTING OFFICE,
WASHINGTON, DC 20402.

ORDER FROM NATIONAL TECHNICAL INFORMATION SERVICE (NTIS), SPRINGFIELD, VA 22161.

14. NUMBER OF PRINTED PAGES

27

15. PRICE

A03