

Time-Division SQUID Multiplexers

K.D. Irwin, L.R. Vale, N.E. Bergren, S. Deiker, E.N.
Grossman, G.C. Hilton, S.W. Nam, C.D. Reintsema, and
D.A. Rudman
Mail Stop 814.03
National Institute of Standards and Technology
325 Broadway
Boulder, CO 80305

M. E. Huber
Dept. of Physics
University of Colorado at Denver
Denver, CO 80217-3364

Proceedings of the 9th International Workshop on Low Temperature Detectors
July 23-27, 2001, Madison, Wisconsin
pp. 301-304

Eds. F.S. Porter, D. McCammon, M. Galeazzi, and C.K. Stahle
AIP Conference Proceedings 605

Time-Division SQUID Multiplexers[†]

K.D. Irwin¹, L.R. Vale¹, N.E. Bergren¹, S. Deiker¹, E.N. Grossman¹, G.C. Hilton¹, S.W. Nam¹, C.D. Reintsema¹, D.A. Rudman¹, and M.E. Huber²

1. NIST, Boulder, CO, USA

2. University of Colorado at Denver

[†]Contribution of the U.S. Government, not subject to copyright.

Abstract. SQUID multiplexers make it possible to build arrays of thousands of low-temperature bolometers and microcalorimeters based on superconducting transition-edge sensors with a manageable number of readout channels. We discuss the technical tradeoffs between proposed time-division multiplexer and frequency-division multiplexer schemes and motivate our choice of time division. Our first-generation SQUID multiplexer is now in use in an astronomical instrument. We describe our second-generation SQUID multiplexer, which is based on a new architecture that significantly reduces the dissipation of power at the first stage, allowing thousands of SQUIDs to be operated at the base temperature of a cryostat.

SCIENTIFIC MOTIVATION

The success of superconducting transition-edge sensor (TES) microcalorimeters and bolometers has led to a demand for large arrays for materials analysis and astronomy. Superconducting Quantum Interference Device (SQUID) multiplexers (MUX) are necessary components of such arrays. Our first-generation 8-pixel SQUID MUX [1] operates without significantly contributing to the noise of an 8-pixel TES bolometer [2]. It has now been successfully deployed in a submillimeter bolometer array, FIBRE, at the Caltech Submillimeter Observatory [3].

The new multiplexer architecture described in this paper will be used in a 1000-pixel x-ray microanalysis array being developed at NIST, in SAFIRE [4], a 288-pixel first-light instrument on SOFIA, and in SCUBA-2 [5], a 12,800-pixel submillimeter bolometer array to be deployed at the James Clerk Maxwell Telescope in ~2005. It is also being developed as an option for NASA's x-ray observatory, Constellation-X [6].

ORTHOGONAL FUNCTIONS AND MULTIPLEXING

In order to multiplex with minimal crosstalk, the signals from different pixels are encoded by multiplying them with different elements from an orthogonal set of modulating functions, such as a boxcar function for time-division multiplexing (TDM) or a sinusoid for frequency-division multiplexing (FDM). They are then added into one output channel. The elements can be decoded by multiplying the signal from the output channel by the same functions. The fundamental limit on the number of signals that can be encoded in one output channel with a given bandwidth is independent of

the choice of modulating function. Thus, practical issues with amplifier noise and the technique used to encode the data determine the choice of a multiplexing scheme.

SQUID multiplexers based on TDM and FDM are being developed. In TDM SQUID multiplexers [1], individual TES devices are biased with a constant voltage. They are encoded by turning their respective SQUIDs on at different times and adding the outputs of each SQUID in a second-stage SQUID. In order to prevent noise aliasing in the encoding, the bandwidth of the pixel is limited to below the Nyquist frequency of the switching by a one-pole low-pass L/R filter formed by the inductance of the SQUID input and the resistance of the TES. In FDM SQUID multiplexers [7], the TES devices are encoded by AC-modulating the TES bias voltage at different frequencies and adding the outputs of the channels in one SQUID. In order to prevent noise from getting into adjacent frequency bands, the bandwidth is limited by an LC tank circuit formed by an inductor and a capacitor in the bias circuit of each pixel.

The practical issues affecting the choice of a multiplexing scheme include the efficiency of bandwidth usage, the complexity of room-temperature electronics, the difficulty of connecting detectors to SQUIDs, the power dissipation, the slew rate, and the difficulty of constructing bandwidth-limiting filters. We briefly mention each issue, and consider the bandwidth-limiting filters in more detail.

In TDM, dead time due to switching transients limits the number of channels that can be multiplexed in the available bandwidth. In FDM the number of channels that can be multiplexed is similarly limited by the necessary frequency spacing between the adjacent channels to reduce crosstalk. TDM requires complex electronics due to the switched digital feedback needed to linearize the SQUIDs. FDM requires complex electronics to simultaneously demodulate the signals in all of the passbands. TDM requires leads from each pixel to the first-stage SQUIDs, and a SQUID must be lithographically fabricated for each pixel. FDM requires leads from each pixel to the LC tank circuit, and a different LC tank circuit must be fabricated for each pixel, but fewer leads are required from the LC tank circuits to the SQUIDs. In each case, one or two SQUIDs are on per column, dissipating a power of $\sim 1 \mu\text{W}$ in the first stage for a kilopixel array. Further, it can be difficult in FDM to handle the required slew rates of the carrier signals.

The bandwidth required for single TES microcalorimeters and bolometers in most applications is 0.1 to 10 kHz. If good enough filters are available, it is possible to multiplex 32 channels in the several MHz bandwidth available with series-array SQUIDs with room-temperature feedback circuits. For TDM, it is relatively simple to lithographically fabricate small L/R one-pole filters that roll off at 1 to 100 kHz.

With FDM, it is necessary to either operate at a higher bandwidth or to use large capacitors at each pixel. Operating at high bandwidth requires high-bandwidth SQUID circuits and high-performance room-temperature circuitry to simultaneously demodulate many high-frequency channels for each column. It will be challenging both to develop the fast room-temperature electronics for the application, and to fit them into the power specifications of a satellite mission. If operation at lower frequencies is desired, large ($\sim 100 \text{ nF}$) capacitors may be necessary at each pixel. It is difficult to lithographically fabricate capacitors this large, and it may be necessary to connect a component capacitor to every pixel.

Because of the relative ease of lithographically fabricating low-frequency filters for TDM, we have chosen to pursue this option.

SERIES-ADDRESS MULTIPLEXER

In our first-generation 1x8 SQUID MUX chips, the first-stage SQUIDs in one row are turned on by applying an address *voltage* in *parallel* to their address resistors [1]. All the SQUIDs in a column are wired in series and connected to the input coil of a second-stage series-array SQUID. Unfortunately, in order to prevent parasitic leakage currents from turning on the wrong SQUIDs, it proved necessary to use $\sim 100 \Omega$ address resistors. The power dissipation in these resistors is two orders of magnitude larger than in the SQUIDs, which makes it unrealistic to place a large array of address resistors at the base temperature of some cryostats. Further, a hard address voltage must be applied to the row to prevent crosstalk. If a small shunt resistor is used to provide the address voltage, the address current can be very high (tens of milliamps), making implementation difficult, although it works well for small arrays [2,3].

We are now developing a series-address multiplexer architecture. In this approach, address *currents* are applied to turn on a row of first-stage SQUIDs in *series*. A $\sim 1 \Omega$ address resistor, R_A , shunts each first-stage SQUID. The current through the address resistor is inductively coupled to a second-stage SQUID shared by all the first-stage SQUIDs in a column. The coupling to the second stage can occur through either a transformer coil that is common to all of the first-stage SQUIDs (Fig. 1), or separately wound input coils from each channel to the second stage.

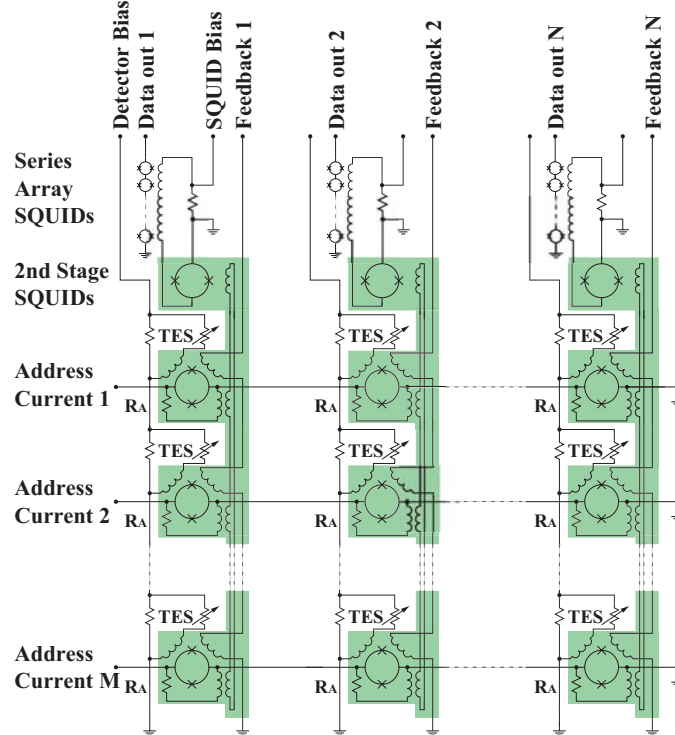

FIGURE 1. Circuit diagram for series-address SQUID MUX with $M \times N$ pixels. In this version, the first-stage SQUIDs are coupled through a common transformer to the second stage.

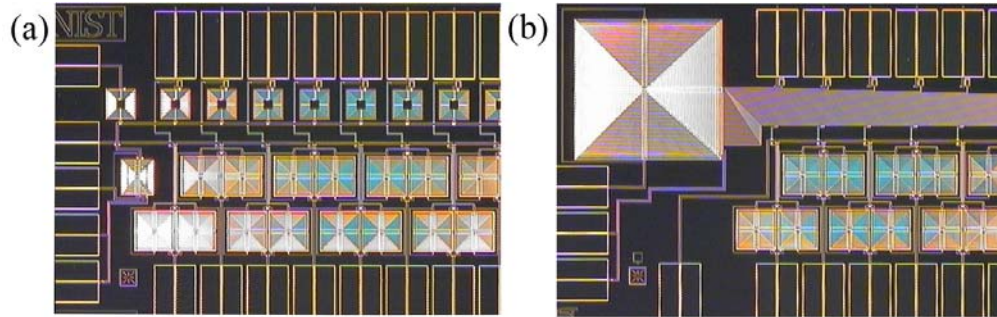

FIGURE 2. Photographs of two styles of 32-channel series-address multiplexer chips. The second stage and a few of the 32 channels are shown in each case. (a) Transformer coupling to the second stage. (b) Separately wound input coils on the second stage from each SQUID.

The second-stage SQUID can be a series array, allowing it to couple directly to room-temperature electronics. However, the series-array SQUIDs dissipate $\sim 30 \mu\text{W}$ for a 32×32 array, which may be too high a power to place at the base temperature of a cryostat. Thus, we place a second-stage SQUID for each column on the same chip as the first-stage SQUIDs, and couple to a third-stage series array at 4K (Fig. 1).

The series-address multiplexer has low enough power ($\sim 1 \mu\text{W}$ for a 32×32 array) to operate at the base temperature of most cryostats. The address line currents are small ($\sim 100 \mu\text{A}$ for our SQUIDs), and address-line crosstalk is negligible.

32-CHANNEL MULTIPLEXER CHIPS

We have fabricated two styles of 32-channel series-address multiplexer chips, incorporating transformer coupling to the second-stage (Fig. 2a), and separately wound input coils on the second stage for each first-stage SQUID (Fig 2b).

At high switching rates, coupling from the common feedback coil to the input coil can be a source of crosstalk between the ‘on’ channel and all of the ‘off’ channels in the column. In these chips we have canceled this coupling by connecting the TES to the input coils of two input SQUIDs with oppositely wound feedback coils. Only one SQUID of the pair is turned on. This configuration nulls this source of crosstalk.

Preliminary tests indicate that the SQUIDs on the 32-channel multiplexer chips work, and that the coupling between the first and second stages agrees with the design values. We are starting to measure performance at high frequency.

REFERENCES

1. Chervenak, J. A., et al., *Appl. Phys. Letters* **74**, 4043-4045 (1999).
2. Staguhn, J. G. et al., these proceedings.
3. Benford, D. J. et al., these proceedings.
4. Shafer, R. A., et al., *Proc. SPIE* **4014**, 98-108 (2000).
5. Duncan, W. D., et al., these proceedings.
6. Stahle, C.K., et al, *Proc. SPIE* **3765**, 82-93 (1999).
7. Yoon, J., et al., *Appl. Phys. Letters* **78**, 371-373 (2001).