

**Comparison of the NIST and NRC Josephson Voltage  
Standards  
(SIM.EM.BIPM-K10.b)**

Yi-hua Tang  
National Institute of Standards and Technology (NIST)  
Gaithersburg, MD 20899, USA  
Telephone: + (301) 975-4691, email: [yi-hua.tang@nist.gov](mailto:yi-hua.tang@nist.gov)

Barry Wood  
National Research Council  
Ottawa, ON K1A 0R6, Canada  
Telephone: + (613) 990-9225, email: [Barry.Wood@nrc-cnrc.gc.ca](mailto:Barry.Wood@nrc-cnrc.gc.ca)

**Abstract:** A comparison between the National Institute of Standards and Technology (NIST) and the National Research Council (NRC) Josephson Voltage Standards (JVS) was carried out at the NRC from August 13 to August 17, 2007. The comparison was made at the 10 V level. It was a two-way direct JVS comparison, which means that the NIST JVS provided a voltage at 10 V and was measured against the NRC JVS with NRC's measuring system (hardware and software). The comparison was repeated by using the NIST JVS measuring system to measure a voltage at 10 V provided by the NRC JVS. The results from the two comparisons were consistent. The difference between the NIST CJVS and the NRC JVS is -0.28 nV with an expanded uncertainty ( $k = 2$ ) of 2.07 nV at 10 V or 2.07 parts in  $10^{10}$ .

## 1. INTRODUCTION

BIPM has been providing NMIs with JVS direct comparisons that are within the scope of EM.BIPM-K10.b at 10 V. Most of these comparisons have been performed under the BIPM protocol Option B, where BIPM provides a stable voltage at 10 V and the NMI's JVS takes measurements against the BIPM JVS voltage. However, this type of direct JVS comparison only compares one Josephson array and its measurement system to a second Josephson array voltage. A complete direct Josephson comparison requires two sets of measurements, with each JVS system taking a set of measurements.

In early 2006, NRC and NIST carried out a direct JVS comparison between the NRC JVS and the transportable NIST compact JVS (CJVS). We were able to make a successful comparison using the NRC JVS measuring system to measure the NIST CJVS. The difference between the two systems (NRC – NIST) was 0.3 nV with an expanded uncertainty of 3.8 nV or 3.8 parts in  $10^{10}$  ( $k = 2$ ).

NIST recently implemented a battery-powered bias supply and corresponding software to perform the comparison against the NRC JVS. The comparison SIM.EM.BIPM-K10.b, based on a proposal in a CPEM 2006 paper, was formulated to complete the comparison between NIST and NRC.

## 2. COMPARISON EQUIPMENT

### 2.1 The NIST compact JVS (CJVS)

The CJVS, constructed at NIST, uses a fixed microwave frequency of 76.76 GHz and integrates the microwave frequency assembly with the cryoprobe. The unique design of the frequency assembly eliminates the need of a frequency counter, thereby reducing the weight of the system. This makes the system compact and transportable. Fig.1 shows the

76.76 GHz microwave assembly. A local 10 MHz quartz oscillator is phase-locked to a 10 MHz frequency reference from a Global Positioning System (GPS) or Cesium clock. A quadrupler generates a 40 MHz frequency from the 10 MHz signal. Inside the cryoprobe, the 40 MHz signal is supplied as a reference to a Dielectric Resonance Oscillator (DRO) with an internal phase-lock loop (PLL) circuit. The DRO operates at 7.68 GHz. Its tenth harmonic 76.8 GHz is mixed with the 76.76 GHz GUNN Oscillator, creating a 40 MHz intermediate frequency (IF). This 40 MHz IF output is appropriately amplified and mixed with the original 40 MHz quartz signal to provide a dc error signal. The error signal is provided to the GUNN tuner to generate a phase-locked stable microwave frequency at 76.76 GHz for the Josephson array operation. The uncertainty of the fixed 76.76 GHz frequency is determined by the 10 MHz frequency reference and is in the range of a few parts in  $10^{12}$  or better. Commercial bias electronics and software developed at NIST control the measurement process.

The resistance of the precision measurement leads of the NIST CJVS is  $7.0 \Omega$  (including the resistance of the filters). The most recent measurement of the leakage resistance of the NIST CJVS cryoprobes was made on July 27, 2007. The leakage resistance between the two precision measurement leads was  $4.0 \times 10^{11} \Omega$ , which is consistent with previous measurements. The voltage drop due to the leakage resistance at 10 V is 0.175 nV.

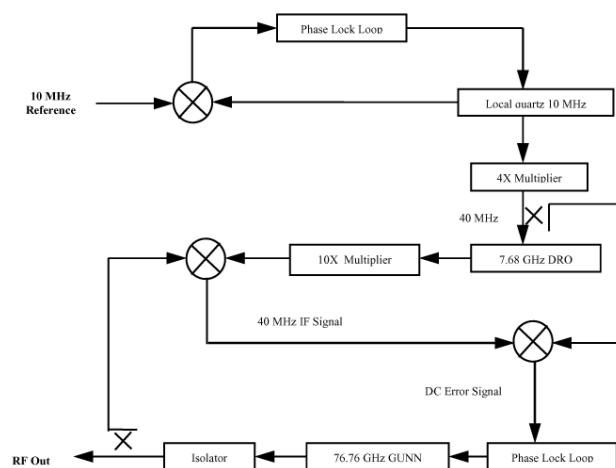

Fig.1 Block diagram of a 76.76 GHz source for Josephson array operation

Other details of the CJVS are as follows:

- Precision measurement leads resistance:  $7 \Omega$
- Leakage resistance between the precision measurement leads:  $4 \times 10^{11} \Omega$

- Josephson junction array: Hypres\* 10 V SN2546E3
- Null detector: Agilent\* 34420A SN576912; range: 1 mV
- 10 V DVM: Agilent\* 34420A SN612213; range 10 V
- Bias source : VMetrix\* JBS100D
- Software : NISTVolt for Windows

## 2.2 The NRC JVS

The NRC JVS system has been described previously in Rapport BIPM-2005/03 and the CPEM 2006 Digest. It contains a Hypres 10V SIS array and a custom built cryoprobe. The bias control for the Josephson array is an Astro Endyne JBS 501, which has been subsequently modified by adding battery operation, electrical isolation of the voltage and current monitors, and optical isolation of all digital control lines.

The rf source is a Gunn diode whose frequency is counted and phase locked with an EIP 578B. The frequency counter has been calibrated at a single frequency against a NRC frequency standard and at many frequencies using the PTB/IMST synthesizer. Calibration deviations at the voltage comparison operating frequency of 76.76 GHz are within 3 Hz. The 10 MHz reference for the EIP is a chain of synthesizers that are linked to the NRC ensemble of cesium clocks.

The gain and linearity of the nanovolt detector, an Agilent 34420A, was determined by direct comparison with the NRC JVS system and represents a significant uncertainty component in this comparison. All measurements were made on the 10 mV range within the range of  $\pm 1.2$  mV ( $\pm 7$  steps) and the nanovoltmeter was calibrated on each of these steps. The noise of each calibration point is typically 0.9 nV, but the repeatability of each data point from day to day is significantly larger and is more reasonably estimated with an average variation of 2.8 nV.

The upper limits of the leakage effect can be estimated from the voltage dividers formed by the potential leads resistance ( $2.48 \Omega$ ) and the leakage resistance between the plus and minus potential leads ( $5.9 \times 10^{11} \Omega$ ). The voltage drop due to the leakage resistance at 10 V is 0.042 nV.

---

\* Certain commercial equipment, instruments, or materials are identified in this report in order to facilitate understanding. Such identification does not imply recommendation or endorsement by NIST neither by NRC, nor does it imply that the materials or equipment identified are necessarily the best available for the purpose.

### 3. COMPARISON SETUP

Simultaneous biasing of both arrays is achieved by insertion of a shorting switch in parallel with the nanovoltmeter. One array and its associated bias circuitry and measurement system are used to control and measure the second array which acts simply as a voltage source. The second array is kept disconnected from its bias circuitry.

Fig. 2a shows the setup using the NRC JVS to measure the NIST CJVS. With the nanovoltmeter shorted, the NRC bias system biases both the NRC array and the CJVS array to the same voltage. Open circuiting the NRC bias caused both arrays to jump several steps away from the bias voltage, but both arrays remained within one step of each other. Opening the nanovoltmeter switch usually resulted in a jump between the two arrays of one or two steps. A simple manual toggle switch was used as the nanovoltmeter switch in the comparison that was carried out in February 2006. An automatic switch controlled by the NRC software was implemented in this comparison to improve the efficiency of the process. Note that the nanovoltmeter switch has no thermal emf measurement contributions since it is an open circuit and not in the potential measurement loop.

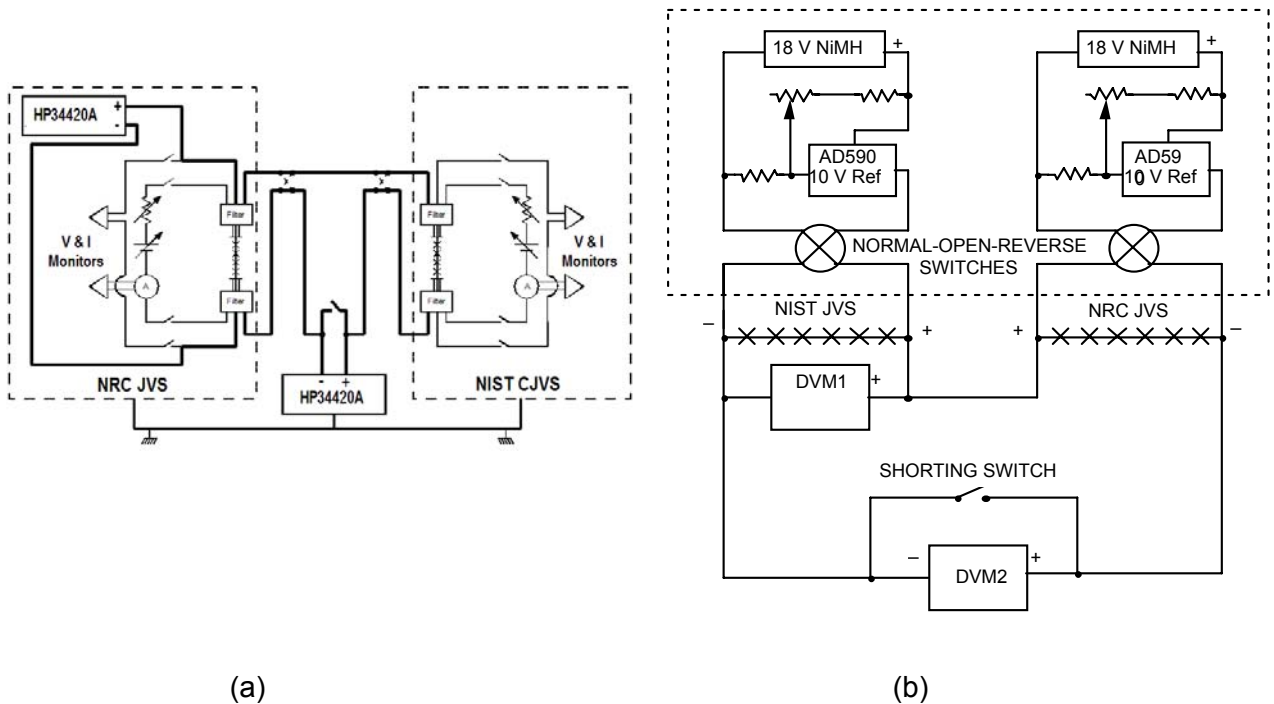

Fig. 2 Experimental setup. (a) shows the setup using the NRC JVS to measure the NIST CJVS. (b) shows the setup using the NIST CJVS to measure the NRC JVS with a battery powered bias source JBS100D.

Fig. 2b shows the setup using the NIST CJVS to measure the NRC JVS. The two systems are connected in series opposition with the difference voltage  $V_1-V_2$  connected to DVM2. DVM1 is connected across  $V_1$ . A battery-powered bias source is used to set both array systems near 10 V when the shorting switch across DVM2 is closed. A shorting switch across DVM2 is used in conjunction with the open circuit position of the reversing switches to bias both arrays with the same bias source. The shorting switch provides a fast way to put both arrays on steps at nearly the same voltage.

#### 4. MEASUREMENT PROTOCOL

##### 4.1 NRC JVS protocol

The NRC system has two dvms, a system dvm connected at all times across the NRC array and a nanovoltmeter to measure the difference voltage between the NRC array and the device under test which in this case is the CJVS array. Both the nanovoltmeter and the system dvm are Agilent 34420A. Data acquisition is performed by programming both the system dvm and nanovoltmeter to simultaneously acquire and internally store a burst of readings. This method ensures that there is no IEEE bus activity during the data acquisition.

The operating voltage step of the NRC array and the NIST CJVS array, as well as the voltage difference between the two arrays, can thus be determined for each individual data point. The NRC data acquisition and rejection algorithm [1] examines the sequential data stream and only accepts a particular point if the current measurement and the previous measurement are within a small fraction of a step voltage. This algorithm effectively removes data that corresponds to a step transition from either Josephson array. Each of the accepted data points is then corrected for the nonlinearity of the nanovoltmeter and finally corrected to the voltage equivalent to the operation of each Josephson array at a specific step.

##### 4.2 NIST CJVS protocol

In a direct Josephson comparison, the parameter of interest is the amount by which the difference voltage deviates from its theoretical value. Comparisons are made by connecting the standards in series opposition and measuring the difference voltage  $V_d$  with a sensitive digital voltmeter (DVM) such that

$$V_d = V_{a1} - V_{a2} = (N_1 f_1 - N_2 f_2) / K_{J-90} \quad (1)$$

The difference between the theoretical value  $V_d$  and the voltmeter's estimate of the actual difference  $V_m$  can be modeled by

$$V_d - V_m = (V_o + mt + V_n + \delta) (1 + E_g) \quad (2)$$

where  $V_o + mt$  represents an offset voltage with a fixed and a linearly drifting component. The offset voltage is assumed to include both the voltmeter offset and thermal emfs in the measurement loop.  $V_n$  is the random time dependent noise in the meter readings and any other unaccounted effects such as DVM nonlinearity.  $E_g$  is the gain error of the voltmeter.  $\delta$  is the amount by which the measured voltage between the two standards differs from its theoretical value.

Contributions to  $\delta$  are:

1. A discrepancy between  $f_1$  or  $f_2$  as used in the equation and the actual frequencies applied to the Josephson arrays.
2. Leakage current  $I_L$  that results in a voltage drop across the resistance of the measurement loop.
3. A bias current dependence of the step voltage (sloped steps).
4. Uncorrected thermal offset and drift.
5. Any additional unknown effects. Note – no uncertainty is being ascribed to the value or accuracy of  $K_{J-90}$ .

Solving Eq. 2 for  $\delta$  gives

$$\delta = (V_d - V_m) / (1 + E_g) - V_o - mt - V_n \quad (3)$$

The unknowns in this equation are  $V_o$ ,  $m$  and  $\delta$ . They can be estimated by making sets of measurements with two or more polarity reversals. Rather than using a reversing switch, the polarity of each array is reversed by changing the array bias to reverse the signs of  $N_1$  and  $N_2$  but not the magnitude.

The data set is an array  $V_d(i)$ ,  $V_m(i)$ ,  $t(i)$ , and  $P(i)$  for  $i = 1$  to  $N$  where  $V_d(i)$  is the  $i^{\text{th}}$  theoretical difference in array voltages,  $V_m(i)$  is the  $i^{\text{th}}$  meter reading,  $t(i)$  is the time of the  $i^{\text{th}}$  reading,  $P(i)$  is the polarity of  $V_{a1}$  and  $V_{a2}$  for the  $i^{\text{th}}$  reading, and  $N$  is the total number of readings.

Equation 3 is a model for the data set. Best estimates for  $V_o$ ,  $m$  and  $\bar{\delta}$  are computed using a 3 parameter fit that minimizes the RSS sum of the residuals  $R(i)$  to the model of Eq. 3 where:

$$R(i) = V_d(i) - V_m(i) / (1+E_g) + V_o + mt(i) - \bar{\delta} \quad (4)$$

NISTVOLT software implements the measurement protocol described above. In the comparison a sequence of array polarity changes + - + - + - is used.

## 5. RESULTS AND UNCERTAINTY

### 5.1 Direct comparison using the NRC protocol

The comparison was made using an automated data acquisition system along with the NRC JVS software. This significantly improved the efficiency of the data taking process. Data was acquired on two successive days, each over a time period of about 90 minutes. In total, 36 points were taken with no obvious distinction between the two data sets. Each point is the mean value of a pair of measurement sets with different polarities of the arrays. Each measurement set consists of 40 readings with a mean standard deviation of  $\approx 2$  nV. The nanovoltmeter DVM used for measuring the difference of the two arrays is always on the 10 mV range but all measurements were kept within  $\pm 1.2$  mV.

Fig. 3 shows the measurement results from two consecutive days. The combined correction for the difference between the NIST CJVS and the NRC JVS is 0.133 nV. All the measurement results in Fig. 3 have been corrected to reflect the real voltages at the outputs of both cryoprobes.

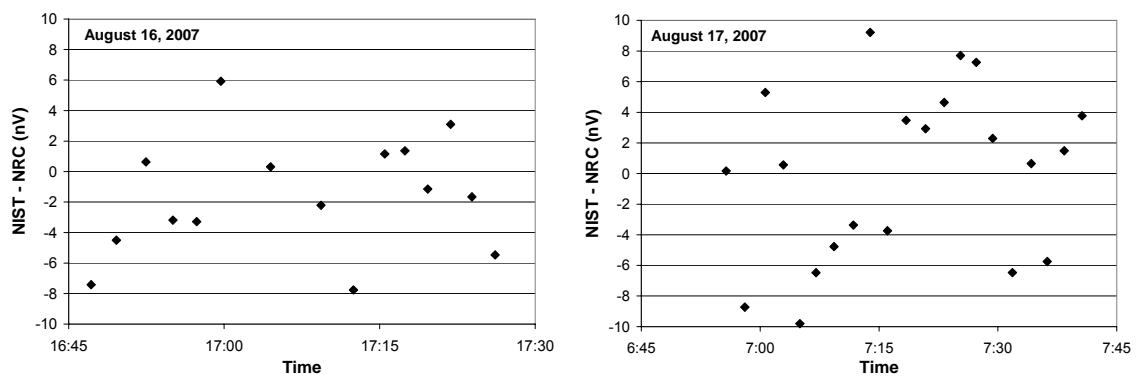

Fig. 3 Measurement results of the NRC JVS against the NIST CJVS.

### 5.2 Direct comparison using the NIST protocol

The measurements from comparing the NIST CJVS against the NRC JVS were made manually by operating the JBS100D. The NISTVOLT software was used for the data



acquisition and calculation of the difference between the two JVS systems. The difference between the two arrays was always controlled within 1 mV. In the case of a step jump during the measurement causing the DVM range to change to 10 mV, the measurement was repeated to avoid the impact of a change in the DVM gain error. Fig. 4 shows the results from the NIST CJVS measuring the NRC JVS. A total of 30 points were taken with 15 points using the DVM in the normal polarity for the measurements and 15 points using the DVM in reversed polarity. We observed that there was a bias related to the DVM polarity. The final result was calculated based on all of the points. Future investigation is planned to better understand the influence of the DVM polarity bias. One possible cause could be the design of the JBS100D. In Fig. 2b where both DVM1(-) and DVM2(-) are connected to the NIST CJVS precision measurements leads, it is possible that the DVM1 bias current may affect the measurement taken by DVM2. We plan to make changes to the JBS100D wiring to improve the measurements related to DVM polarity.

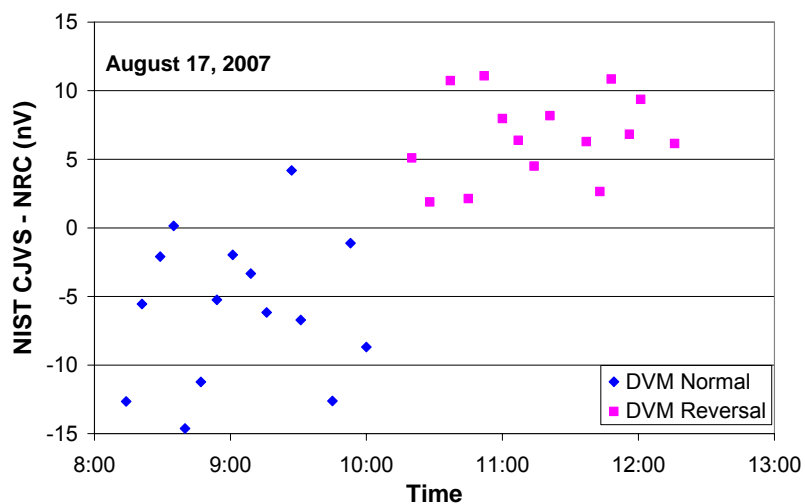

Fig. 4 Measurement results from the comparison of the NIST CJVS against the NRC JVS. Each point is calculated using a fitted value from 6 iterations of + - + - + - array polarity changes. The DVM used for measuring the difference of the two arrays is always on the 1 mV range.

Same as in Fig. 3, all the measurement results in Fig. 4 have been corrected to reflect the real voltages at the outputs of both cryoprobes.

The DVM gain error and linearity, using the -1 mV to 1 mV provided by the NIST CJVS system as the voltage source, was measured by the NRC JVS system before the comparison. However, a linearity correction was not made to the raw data taken by the NIST CJVS measurements.

### 5.3 Results and uncertainty analysis

Table 1 lists the differences between the NIST CJVS and NRC JVS with the Type A uncertainties. The difference  $D_{NRC}$  of NIST- NRC measured by the NRC JVS is the mean of the differences of all the measurements calculated as

$$D_{NRC} = \frac{\sum_i D_i^{NRC}}{N_{NRC}} \quad (5)$$

where  $N_{NRC}$  is the total number of NRC measurements. The Type A uncertainty of the NRC measurements is the standard deviation of the mean calculated as

$$u_A^{NRC} = \frac{\sigma_{NRC}}{\sqrt{N_{NRC}}} = \frac{\sqrt{\frac{\sum_i (D_i^{NRC} - D_{NRC})^2}{N_{NRC} - 1}}}{\sqrt{N_{NRC}}} \quad (6)$$

where  $\sigma_{NRC}$  is the standard deviation of the measurements made by the NRC JVS. For the measurements made by the NIST CJVS the difference is the mean difference of the two data sets with normal DVM polarity and reversed DVM polarity

$$D_{NIST} = \frac{\frac{\sum_i D_i^{NIST+}}{N_{NIST+}} + \frac{\sum_i D_i^{NIST-}}{N_{NIST-}}}{2} \quad (7)$$

where  $D_i^{NIST+}$  is the  $i$ th measurement and  $N_{NIST+}$  is the number of measurements taken by NIST CJVS with DVM normal polarity,  $D_i^{NIST-}$  is the  $i$ th measurement and  $N_{NIST-}$  is the number of measurements taken by NIST CJVS with DVM reversed polarity. In the comparison, an equal number of DVM normal polarity and reversed polarity measurements was taken. Type A uncertainty of the NIST CJVS measurements is the pooled standard deviation of the mean of all the measurements

$$u_A^{NIST} = \sqrt{\left(\frac{u_A^{NIST+}}{2}\right)^2 + \left(\frac{u_A^{NIST-}}{2}\right)^2} \quad (8)$$

where  $u_A^{NIST+}$  and  $u_A^{NIST-}$  are the standard deviations of the mean for data sets with normal and reversed DVM polarity, respectively.

Table 1. Differences between the two JVSs and associated Type A uncertainties

	Made by NRC	Made by NIST
NIST - NRC (nV)	-0.66	0.10
Number of measurements	36	15
Standard Deviation (nV)	4.94	3.09
Type A uncertainty (nV)	0.82	0.80

Table 2 lists the Type B components from various sources for each JVS system. The leakage resistance between the precision measurement leads of each cryoprobe has been measured. The combined correction of 0.133 nV for the leakage resistance from both cryoprobes is applied to the final calculation. The uncertainty of 0.013 nV was estimated as 10 % of the correction. The DVM gain and linearity of the NRC JVS was measured between +1.1 mV and -1.1 mV against the voltage steps from +7 to -7. The difference between the two arrays in the comparison was limited to the DVM 1 mV range to avoid the impact of gain error and linearity change corresponding to the change in the DVM range. The Type B component of the DVM gain and linearity is calculated based on the DVM measurement and a second order polynomial fit. The same estimation of the Type B contribution was performed for the NIST CJVS DVM. It is assumed that the bias related to the DVM polarity in the NIST CJVS measurements was due to the electromagnetic interference (EMI) in the measurement loop. We estimated the Type B contribution to be 10 % of the mean of the absolute difference of two data sets with normal and reversed DVM polarities. Lastly, the Type B contribution of detector offset, impedance and noise was estimated by a short test using each JVS to measure a zero voltage (short). The uncertainty contributions from the microwave power rectification, uncorrected thermals, and sloped voltage steps are negligible in this comparison. The Type B is the root-sum-square (RSS) of all the components listed in Table 2.

Table 2. Type B uncertainty components of each JVS system

	NRC (nV)	NIST (nV)
Frequency offset and noise	0.39	0.10
Leakage	0.013	0.013
Detector gain and linearity	0.45	0.60
Detector bias	0.02	0.00
Microwave power rectification	0.00	0.00
EMI	0.60	0.60
Detector offset, impedance and noise	0.16	0.15
Uncorrected thermals	0.00	0.00
Sloped steps	0.00	0.00
Type B uncertainty $u_B$ (nV)	0.86	0.87

Table 3 lists the differences and associated combined uncertainty as RSS of Type A and Type B uncertainty.

Table 3. The differences with combined uncertainties

	Made by NRC	Made by NIST
NIST - NRC (nV)	-0.66	0.10
Type A uncertainty $u_A$ (nV)	0.82	0.80
Type B uncertainty $u_B$ (nV)	0.86	0.87
Combined uncertainty (nV)	1.19	1.18

The final reported difference between the NIST CJVS and NRC JVS shown in Table 4 is the mean difference of the measurements made by the NRC JVS and the NIST CJVS. The pooled uncertainty associated with the difference is calculated as Eq. 9.

$$u_c = \sqrt{\left(\frac{u_A^{NRC}}{2}\right)^2 + \left(\frac{u_A^{NIST}}{2}\right)^2 + \frac{(u_B^{NRC})^2 + (u_B^{NIST})^2}{2}} \quad (9)$$

Table 4. The final reported difference between NIST CJVS and NRC JVS and the associated expanded uncertainty ( $k = 2$ ) is

NIST - NRC (nV)	-0.28
Pooled Combined uncertainty $u_c$ (nV)	1.04
Expanded uncertainty (nV) $k = 2$	2.07

## 6. Discussion and conclusion

During the first two days of this comparison, the NIST CJVS used a Hypres Josephson junction array SN279714. A significant difference between the NRC JVS and the NIST CJVS was observed, and it appeared to increase over the two days that it was monitored. The difference using the NIST CJVS to measure the NRC JVS was 9.7 nV with a Type A uncertainty of 2.1 nV from 12 measurements using DVM normal polarity and 5 measurements using DVM reversal polarity. Later the difference using the NRC JVS to measure the NIST CJVS was -26 nV with Type A uncertainty of 2.7 nV from 5 paired measurements. A decision was made to use a second Hypres array SN2546E3. The final results presented above were from using the Hypres array SN2546E3 in the NIST CJVS. The comparison provided evidence that an error of a few parts in  $10^9$ , which would not be observable by other means such as using Zeners as transfer standards, may be detected by a direct array comparison. The array SN279714 is being investigated to determine if the problem we observed during the comparison was related to poor contacts between the array chip and the finger boards that are used for the voltage outputs.

In conclusion, the comparison between the NIST CJVS and NRC JVS demonstrates the consistency in the operation of these JVS systems at 10 V. The difference between the NIST CJVS and the NRC JVS is -0.28 nV with an expanded uncertainty of 2.07 nV or 2.07 parts in  $10^{10}$  ( $k = 2$ ). Small errors in the range of a few parts in  $10^9$  can be detected by the direct JVS comparison.

## Appendix

### Linking SIM.EM.BIPM-K10.b. to BIPM.EM-K10.b

A link between NIST and BIPM at 10 V can be established via the BIPM - NRC direct JVS comparison performed in 2004 [1]. This comparison was included in the BIPM.EM-K10.b comparison report.

The difference between NRC and BIPM was:

$$d_{NRC-BIPM} = 2.8 \text{ nV}$$

The combined standard uncertainty was:

$$U_{NRC-BIPM} = 3.1 \text{ nV}$$

The degree of equivalence of NIST JVS with respect to BIPM is given by a pair of terms and listed in the following Table 1:

$$D_{NIST-BIPM} = (d_{NIST-NRC} + d_{NRC-BIPM}) \text{ and its combined standard uncertainty, } U_{NIST-BIPM}.$$

$$U_{NIST-BIPM} = (U_{NIST-NRC}^2 + U_{NRC-BIPM}^2)^{1/2}, \text{ both expressed in nV.}$$

Table 1. Link between NIST to BIPM via NRC - BIPM comparison in BIPM.EM-K10.b

	NIST - NRC	NRC - BIPM	NIST - BIPM
Difference (nV)	-0.28	2.8	2.52
Combined standard uncertainty (nV)	1.04	3.1	3.27

## REFERENCE

[1] D. Reymann, S. Solve, and B. Wood, "Comparison of the Josephson Voltage Standards of the NRC and the BIPM," CIPM MRA, BIPM.EM-K10.b, 14 pp, Rapport BIPM-2005/03.