

High-Bandwidth Coaxial PWB Transmission Line Probe

N.G. Paulter, R.H. Palm and D.D. Barry
National Institute of Standards and Technology
Gaithersburg, MD

Abstract

The design and evaluation of a wide bandwidth (3 dB attenuation bandwidth > 20 GHz), 50 Σ , coaxial probe for the electrical characterization of printed wiring board (PWB) transmission lines is described. The probe made thousands of repeated contacts, using spring-loaded interconnects, without affecting probe performance. The probe contains an internal mechanism for dissipating static charge on the signal line of the PWB transmission line and is long enough (approximately 10 cm) to act as a transfer standard for characteristic impedance testing per the time-domain reflectometry test method described in IPC TM 2.5.5.7.

Introduction

High-performance (high-speed, high-frequency, high data rate) printed wiring boards (PWBs) contain many transmission lines, the characteristics of which are critical to the performance of the board. Three important performance characteristics of a transmission line are its characteristic impedance, propagation delay, and loss. The measurement of these characteristics are typically performed using time-domain reflectometry (TDR)¹ because of the ease of use of the instruments, the ready interpretation of the data, and the relatively low cost of TDR measurement equipment compared to frequency domain tools.

To measure the transmission line (TL) performance characteristics, the TL must be contacted electrically. Requirements for a contacting device that is suitable for PWB TL testing include:

- 50 Σ , characteristic impedance
- Long life (> 100 000 contacts)
- Repeatable contact
- Bandwidth in excess of the bandwidth of the signal being tested.

The contacting device described herein is a coaxial probe that meets these requirements and provides other features that can improve overall measurement system performance and reduce measurement uncertainty (see list below):

Probe contacts: > 100 000, no deterioration of signal²

Characteristic impedance: 50 Σ , $\pm 0.3 \Sigma$, (see Sec. 2.1)

Transition duration (round trip): dependent on static protection (see Table 1)

Internal static protection (no other devices needed).

Although the probe that will be described can be modified to accommodate differential transmission lines, the focus here will be on application to single-ended transmission lines.

Design of the Probe

The probe comprises three sections, the connection to the coaxial environment (typically the connector of a TDR head), the uniform transmission line section, and the PWB TL contact. The mechanical drawings for the connector and transmission line sections are shown in Figures 1 and 2.

The connectorized region provides the electrical interface between the TDR and other electronic instruments. To reduce reflections caused by the interface, the probe is designed so that the inside diameter of the outer (or ground or reference) conductor is uniform over its full length. The outside diameter of the inner (or signal) conductor is uniform in diameter up to where the outer conductor ends, which is where the probe mates to the female connector of another device, such as a TDR head.

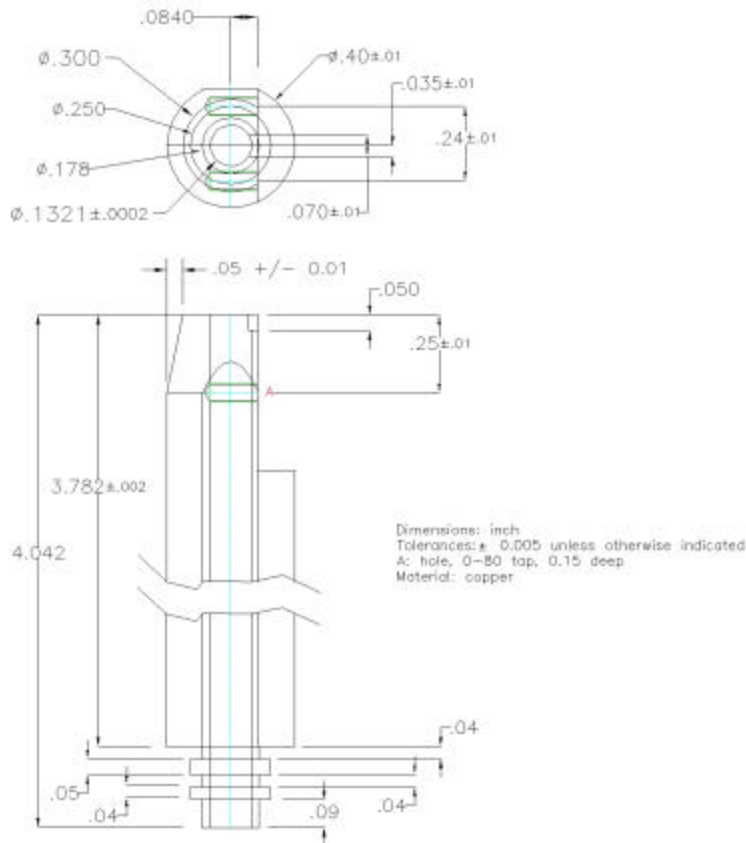

Figure 1 - Mechanical Drawing of the Outer Conductor of the Probe

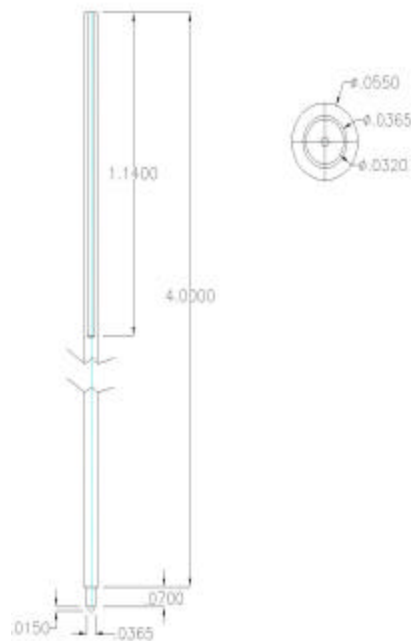

Figure 2 - Mechanical of the Inner Conductor of the Probe

The transmission line is a uniform coaxial transmission line. The dielectric is made of hollow glass spheres constrained on both ends of the transmission line with a dielectric disc. Hollow glass spheres were chosen for several reasons: the permittivity would be near that of air and they are nontoxic, very inexpensive, and fill the small volume completely and

easily. Because air is the primary dielectric and the conductors have high electrical conductivity, propagation loss is not considered here. The primary design considerations are the characteristic impedance and length of the transmission line section. The length of the transmission line section is limited by machining considerations. The center conductor is radially constrained at both ends to keep it centered within the outer conductor. Because the method of constraining the center conductor has changed since the initial design, it may be possible to eliminate the hollow glass spheres. This is presently being investigated.

The contact region is the most important part of the probe for maintaining high bandwidth. This part must also sustain repeated contacts (many thousands) without affecting the performance of the probe. To provide the repeated contact requirement, the probe uses spring-loaded interconnects for both the ground and signal contact.² To maintain the high bandwidth at the contact region of the probe, the probe is designed so that when the spring-loaded interconnects are fully depressed, the heads of these interconnects are recessed into the body of the probe. Within the contact region, a mechanism for shunting static on the signal line of the TL, the static dissipation element (sde) is also provided. The probe was operated hundreds of times with the sde in place with no apparent change in the electrical performance of the sde.

Probe Characterization

The probe was characterized using TDR measurements. The primary performance characteristic of the probe that was measured with TDR is its characteristic impedance, Z_{prb} , and its step-response transition duration.

Characteristic Impedance

The value of Z_{prb} is determined using the ratio of the amplitude, V_r , of the pulse reflected at the probe/TDR interface to the amplitude, V_i , of the incident pulse. The ratio of these pulses is the reflection coefficient, D ,

$$\rho = \frac{V_r}{V_i}. \quad (1)$$

D is relative to the reference impedance Z_{ref} , of the air line standard, which is $50 \Sigma \pm 0.3 \Sigma$. (Details of how V_r and V_i are determined are not provided here but can be found in.³) The characteristic impedance, Z_{prb} , of the probe is computed from D and Z_{ref} :

$$Z_{prb} = \frac{1 + \rho}{1 - \rho} Z_{ref}. \quad (2)$$

Z_{prb} can also be calculated from its geometry and the material properties. The probe was made using hollow glass spheres for the dielectric. The calculated value of Z_{prb} was $50.01 \Sigma \pm 1.050 \Sigma$. The dominant contributor to this uncertainty is the uncertainty in the permittivity of the hollow glass spheres. The transmission line segment of the probe was also fabricated and tested using TDR. The measured value of Z_{prb} is $50.04 \Sigma \pm 0.3 \Sigma$, where the dominant contributor to uncertainty was that from the reference airline.

Step Response

The TDR waveforms corresponding to the probe under different conditions are shown in Figure 3. The probes were tested with and without the hollow glass spheres and with and without the static dissipation element. The transition duration of the step response of the probe is approximated using the root-difference-of-squares method; the results are shown in Table 1. The results are also for a single pass through the probe. The reference or incident step, $v_{inc}[t]$ (where “[t]” is a discrete time index), is obtained by placing a short-circuit or open-circuit termination at the end of the 50Σ airline standard that is not connected to the TDR and then acquiring the waveform. The reflected step, $v_{ref}[t]$, is then obtained by replacing the short-circuit termination with the probe and acquiring another waveform without changing the timebase delay or sensitivity (time per division) settings of the TDR. These time-domain waveforms are processed³ to obtain their transition duration values, which are shown in Table 1.

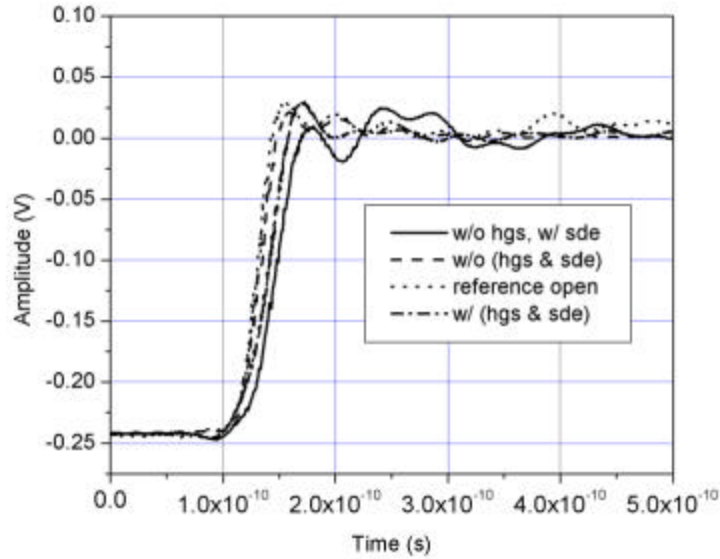

**Figure 3 - TDR Waveforms Corresponding to the Probe Under Different Conditions:
hgs – Hollow Glass Spheres, sde – Static Dissipation Element.**

Table 1 - Measured, t_m and Approximated Step Response, t_a , Transition Durations (10 % to 90 % of amplitude). t_a is Computed from:

$$t_a = \sqrt{t_m^2 - t_{a,ref}^2},$$

where $t_{a,ref}$ is 24.9 ps for The Reference Short and 27.5 ps for the Reference Open.

**The Uncertainty in the All Measured Values (middle column) is ± 2 ps.
No Uncertainties Are Claimed For The Approximate Values (Right Column).**

	t_m (ps)	t_a (ps)
probe, shorted	52.7	32.8
probe, open	38.8	19.4
probe (w/o hgs), shorted	67.5	44.4
probe (w/o hgs), open	36.9	17.4
probe (w/o hgs, w/o sde), shorted	31.5	13.6
probe (w/o hgs, w/o sde), open	27.9	3.3
50 ? air line (15 cm), open	29.1	6.7

References

1. IPC-2141A, "Design Guide for High-Speed Controlled Impedance Circuit Boards," March 2004, IPC, 2215 Sanders Road, Northbrook, IL.
2. N.G. Paulter and R.H. Palm, "A wide bandwidth printed wiring board transmission line probe," IPC Printed Circuits Expo 1999, 14 - 18 March 1999, Long Beach, CA, USA, pp. S19-4-1 - S19-4-4.
3. IEEE Standard 181-2003, IEEE Standard on Transitions, Pulses, and Related Waveforms, The Institute of Electrical and Electronic Engineers, New York, USA, July 2003.