

Parallel Configuration for Conjugate Regenerative Dividers*

J. F. Garcia Nava¹, A. Hati², C.W. Nelson², A. Sen Gupta³, F. L. Walls¹ and T.N. Tasset⁴

¹Total Frequency, Boulder, CO, USA

²NIST Boulder, CO, USA

³National Physical Laboratory, New Delhi, INDIA

⁴University of Colorado, Boulder, CO, USA

Abstract- In this paper we discuss an alternate design of a self-starting conjugate regenerative divider (CRD), which uses two parallel loops instead of one series loop as in conventional regenerative divider. This is accomplished by making the first loop oscillate at one conjugate frequency while the second loop oscillates at the other conjugate frequency, for example $\nu/4$ and $3\nu/4$. As before the two conjugate frequencies are harmonically related and sum to the input frequency. The advantages of this new configuration are that one can optimize each loop for phase shift, gain, and noise performance and that the individual amplifiers do not have to span the entire bandwidth of the two conjugate frequencies. A prototype of the divide-by-four circuit has been constructed for input frequencies of 400 MHz as well as for 10 GHz.

I. INTRODUCTION

The reason for so much attention devoted to regenerative dividers in recent years is the high operating frequency, clean sinusoidal signals, and improved phase noise performance. Several papers on the theory of operation of regenerative dividers [1-3], as well as on its noise performance [4-7] have already been reported. They are widely used in low noise frequency synthesis [7-8]. Although in his original proposal Miller [1] had conceived the idea of a general division by N ($N \geq 2$), regenerative dividers subsequently designed and studied, have been exclusively divide-by-two configurations. To obtain greater division ratios regenerative dividers have been cascaded, thus increasing the amount of hardware [9]. Also, it has been possible to achieve only binary division ratios unless multipliers are added within the loop, or the mixer is driven into hard saturation, which generates harmonics. Such dividers are generally not self-starting.

In our previous work we proposed a self-starting series conjugate regenerative divider (CRD) that permits division by 2, 3, 4, 5, 6, etc [10]. A distinct difference in that approach compared to that of Miller, is that the loop

oscillates simultaneously at two harmonically related conjugate frequencies, for example $\nu/4$ and $3\nu/4$. This removes the necessity of using nonlinear elements (e.g., frequency multipliers), within the feedback loop, to obtain integer frequency division ratios higher than 2. The linear nature of the previous design makes it possible for the divider to be self-starting. Frequency selection in the series configuration was accomplished by using a notch filter at $\nu/2$ and a series filter with transmission peaks at roughly the two conjugate frequencies of interest. The primary disadvantage of the previous configuration is that it is difficult to simultaneously optimize the loop phase shift and set the proper gain for each conjugate frequency, which is necessary to optimize the noise performance of the CRD.

In the present paper we discuss an alternative design of a self-starting CRD that uses two loops in parallel instead of one loop with series filters. The main advantage of this parallel configuration is that it is much easier to adjust the phase and gain of the individual loops independently, and thus optimize the loop for output power and noise performance. The proposed CRD makes it possible to choose amplifiers optimized for the specific conjugate frequency instead of being restricted to wide band amplifiers that can pass both conjugate frequencies. Another advantage is that we can use band pass filters to pass only the conjugate frequencies of interest instead of entire comb. This configuration is, therefore, much more suitable for microwave frequencies where it is difficult to obtain amplifiers with sufficient bandwidth, gain, and noise performance to span both conjugate frequencies.

II. SERIES CONJUGATE REGENERATIVE DIVIDER

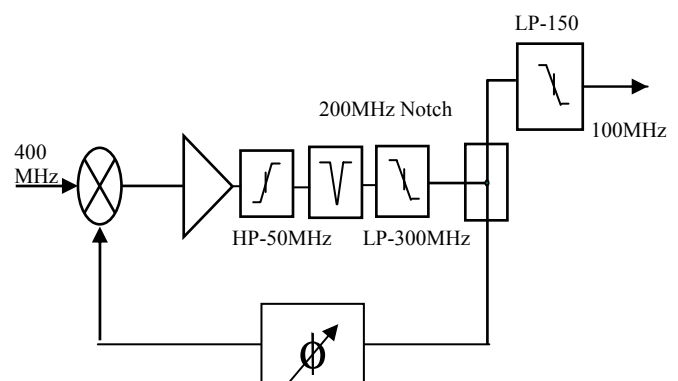

*The article is a contribution of the National Institute of Standards and Technology and is not subject to U.S. copyright

Fig 1. Schematic of a series conjugate divide-by-four circuit for 400 MHz input signal.

Figure 1 shows the block diagram of a series CRD [10]. The operation of a CRD obtained using the notch filter at the half frequency $v/2$ produces a filter transfer function that has two broad peaks approximately symmetrically placed around $v/2$. This then allows operation at the conjugate regeneration pair of $v/4$ and $3v/4$. Fig. 2 shows the output on a spectrum analyzer of the prototype divide-by-four circuit shown in Fig. 1 [10]. The input frequency to the divider was 400 MHz and the power level was between 5 and 10dBm.

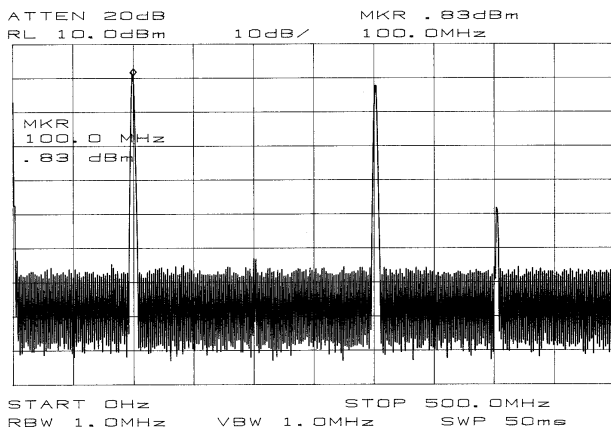

Fig 2. Output of series regenerative divide-by –four

It has been well documented in [10] that by making simple modifications to the transfer function of the feedback loop in the series divide-by-four circuit by choosing different values of the low and high pass filter cutoffs, and adjusting the phase delay, the circuit divides by 3, 5, 8, etc. However, one disadvantage of this configuration is that it is difficult to simultaneously optimize the loop phase shift and gain, and hence the noise performance at both frequencies. Another drawback is it is very hard to operate a series CRD at very high frequencies because the large frequency separation between two conjugate frequencies makes it difficult to find amplifiers with the required bandwidth, gain, and noise performance.

III. PARALLEL CONJUGATE REGENERATIVE DIVIDER

These drawbacks of a series CRD are removed by an alternative design known as the parallel CRD. The general features of this new conjugate regenerative are illustrated by the divide-by-four circuit shown in Fig. 3. In this configuration, the output of the mixer is split into two equal parts. Each of these signals are then amplified and

passed through band pass filters that are centered at the two conjugate frequencies. In this case, $v/4$ and $3v/4$, and then are recombined again to be looped back to the mixer RF port. Each loop also has a phase shifter to adjust the phase shift appropriately so that the oscillation condition is satisfied [10]. Figure 4 shows the spectrum analyzer output of the prototype divide-by-four circuit of Fig. 3.

There are three principal advantages with this parallel configuration. The first advantage is that now the phase adjustment for each loop is independent and it is much easier to achieve oscillation and to optimize the loops.

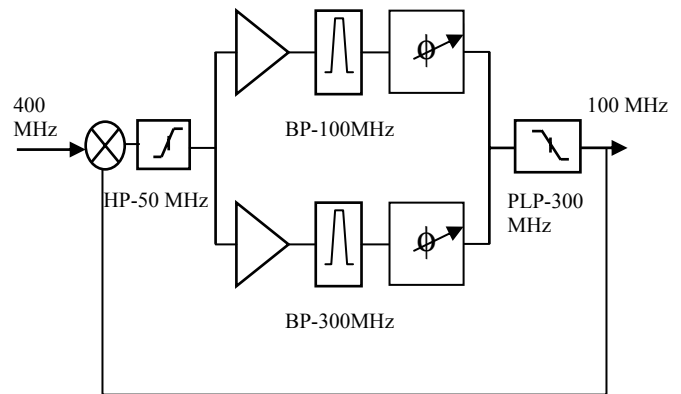

Fig 3. Block diagram of parallel conjugate divide-by-four circuit for 400 MHz input signal.

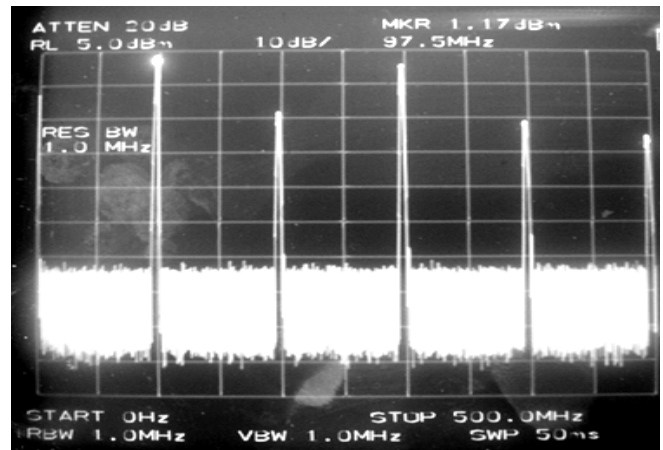

Fig 4. Output spectrum of parallel CRD at 400 MHz input frequency. The primary outputs are 100 MHz and 300 MHz.

The second advantage is that one can make the pass band of the filters in each loop narrow enough that only one pair of conjugate frequencies, rather than the entire comb, propagates around the loop for a high order division. For instance, for division by $3/8$ one can have band pass filters at $3v/8$ and $5v/8$ so that only these two frequencies are able to regenerate. The third advantage is the ability to optimize the

amplifier for each conjugate frequency. This is particularly advantageous for microwave dividers where the large frequency separation makes it difficult to find amplifiers with the required bandwidth, gain, and noise performance.

We have also compared the phase modulation (PM) noise of 400 MHz parallel and series regenerative divide-by-four circuit. Preliminary results on a parallel divider yields a PM noise floor similar to that obtained from the series divider. The result is shown in Fig 5. The only real difference is that it is now much easier to optimize the noise performance and the spurious signals from the other harmonics are greatly reduced.

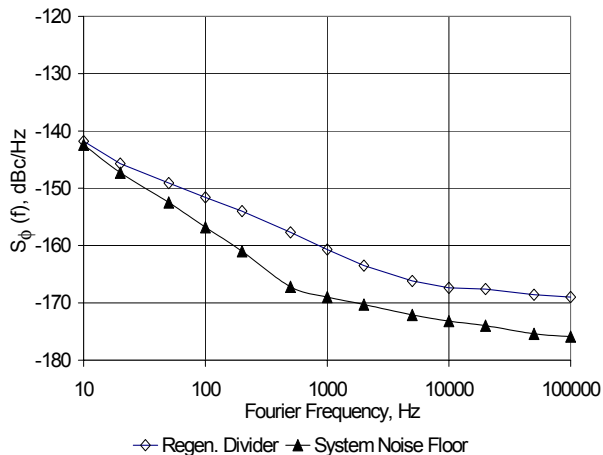

Fig 5. PM noise of parallel divide-by-four CRD at 400MHz.

We have implemented the parallel CRD at X Band where this new approach has the largest impact due to the wide separation of the conjugate frequencies. It is now possible to optimize each loop independently. Figure 6a shows the spectrum of parallel CRD divide-by-four, which indicates the two conjugates frequencies $v/4$ and $3v/4$ as well as the input. $v/2$ has been suppressed by the loop. For convenience, we have used discrete components connected by SMA connectors and coaxial cable. This limits the minimum delay, which is critical in maximizing the bandwidth as explained by Miller [1]. Figure 6b shows the comparison of two spectrums, upper trace is the input power spectrum at 10.7 GHz with about +5 dBm power, while the other trace is the divided-by-four output at 2.68 GHz. The noise at 2 kHz offset frequency for the input signal at 10.7 GHz is -84.3 dBc/Hz (dB below the carrier). The lower trace is the output of the divider with a power of about +5 dBm. At 2 kHz offset frequency the noise is -95.4 dBc/Hz, which is close to 12 dB lower than the input noise as expected from division by 4. The noise floor of the spectrum analyzer was 10 dB lower than these frequencies.

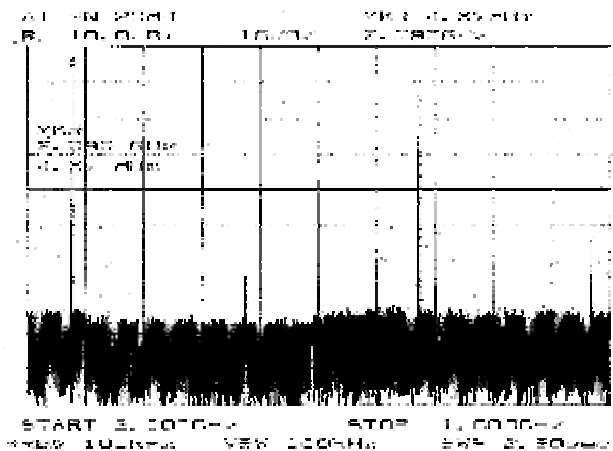

Fig 6a. Output spectrum of parallel CRD for 10 GHz input frequency.

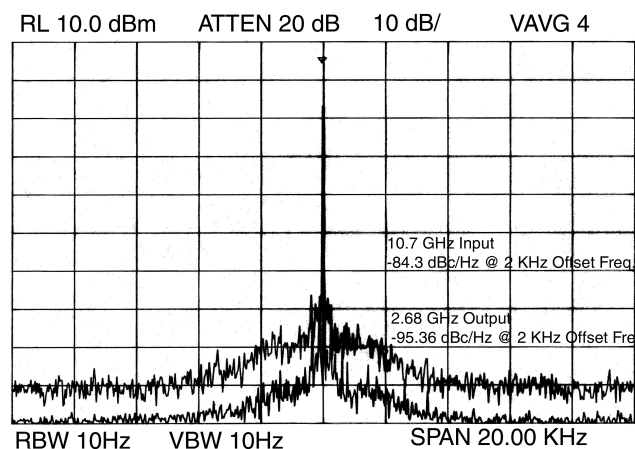

Fig 6b. Phase noise of input signal (10.7GHz) and divided-by-four output (2.68GHz).

IV. CONCLUSION AND FUTURE WORK

An alternative design of a self-starting conjugate regenerative divider has been proposed which permits division by 3, 4, 5, 6... The main advantage of this configuration is that it is much easier to adjust the phase and gain of the individual loops independently and to optimize the output power and PM noise. The proposed parallel CRD makes it possible to optimize the amplifier for each conjugate frequency and to band pass only the conjugate frequencies of interest, instead of entire comb. This configuration is therefore, much more suitable for higher frequencies, especially microwave frequencies, where it is difficult to obtain amplifiers with sufficient bandwidth to span both conjugate frequencies.

In the future, a detailed study on the influence of noise present in one conjugate frequency on the other in a parallel CRD configuration will be addressed.

REFERENCES

[1] R. L. Miller, "Fractional-Frequency Generators Utilizing Regenerative Modulation" Proc. I. R. E., pp 446-457, 1939.

[2] V. F. Kroupa, "Frequency Synthesis: Theory, design and Applications", John Wiley & Sons, pp 62-63, 1973.

[3] R. G. Harrison, "Theory of Regenerative Frequency Dividers Using Double Balanced Mixers", 1989 IEEE MTT-S Symp. Digest Vol-1, pp 459-462, June 1989.

[4] M. M. Driscoll, "Phase Noise Performance of Analog Frequency Dividers", Proc 43rd Annual Freq. Control Symp., pp 342-348, 1989.

[5] E. Rubiola, M. Olivier and J. Gros Lambert, "Phase noise of Regenerative Frequency Dividers", Proc. 5th European Freq. and Time Forum, pp 115-122, March 1991.

[6] E. S. Ferre-Pikal and F. L. Walls, "Microwave regenerative frequency dividers with low phase noise", IEEE Transactions on UFFC, Vol 46, No 1, pp 216 –219, Jan 1999.

[7] M. Mossammaparast, C. McNeilage, P. Stockwell and J. Searles, "Phase Noise of X-Band Regenerative frequency Dividers", Proc, 2000 IEEE Intl. Freq. Control Symp., pp 531-535, 2000.

[8] A. Sen Gupta, D. Popovic and F. L. Walls, "Cs Synthesis – a New Approach", IEEE Transactions on UFFC, Vol 47, No 2, pp 475 –479, March 2000.

[9] M. Mossammaparast, C. McNeilage, P. Stockwell and J. H. Searles, "Low Phase Noise Division From X-Band to 640 MHz", Proc. 2002 IEEE Intl. Freq. Cont. Symp.

[10] A Sen Gupta, J. F. Garcia Nava and F. L Walls, "A novel noise regenerative divide-by-four circuit," Proc. 2002 IEEE Intl. Freq. Cont. Symp., pp. 680-684.

