

Absolute response calibration of a transfer standard cryogenic bolometer

G. Eppeldauer, A.L. Migdall, T.R. Gentile, and C.L. Cromer

Radiometric Physics Division
National Institute of Standards and Technology
Gaithersburg, Maryland 20899

ABSTRACT

A cryogenic bolometer has been developed for use as a transfer standard in an ambient temperature infrared detector response comparator facility at the National Institute of Standards and Technology (NIST). Issues affecting calibration of the bolometer response were studied and a calibration procedure was developed. These issues included frequency dependence, stability, repeatability, and spectral flatness. The relative spectral response was determined from the reflectance of the bolometer absorber and the transmittance of the bolometer window. The bolometer calibration has been tied to the NIST primary standard High Accuracy Cryogenic Radiometer (HACR) using a silicon trap detector and a pyroelectric detector.

1. INTRODUCTION

A new, ambient temperature infrared spectral comparator facility has been developed at NIST to calibrate infrared detectors for spectral responsivity. The computer controlled facility uses a tunable, monochromatic infrared source consisting of a 10 kW argon arc and a room temperature monochromator.¹ Test detectors will be calibrated against working standard and transfer standard detectors in the 2 μm to 20 μm spectral range. The transfer standard for these calibrations is the cryogenic bolometer.

The details of the bolometer design, construction, and characterization have already been published,^{2, 3} thus are only described here briefly. The bolometer is of a composite design, with a doped silicon chip thermal sensor bonded to a thin sapphire disk, which is coated with gold-black on the other (front) side. The bolometer is mounted in a cryogenic dewar with a low thermal conductance to the cold plate. Optical radiation is input to the bolometer through a room temperature KRS-5 window mounted in the side of the dewar. The quiescent temperature of the bolometer is slightly higher than the 4.2 K of the liquid helium bath because of the radiation incident through the window from the ambient surroundings. The incident (chopped) optical power to be measured heats the bolometer, raising its temperature above the quiescent temperature. The bolometer measuring circuit is shown in Fig. 1. The change in temperature results in a change in the impedance (R_D) of the thermal sensor. A constant bias current is supplied through the ballast resistor (R_L), and the signal is measured as a change in voltage across the thermal sensor. The average or DC component of the signal (V_d) is measured at the output of the 70 K junction field effect transistor (JFET), and is used to compensate for changes in the responsivity of the bolometer as the quiescent temperature drifts. The AC component of the JFET output voltage is further amplified using an adjustable gain AC amplifier, and is measured with a lock-in detector.

Earlier measurements^{2,3} showed that the bolometer has high sensitivity (36 pW/Hz^{1/2}) and less than 1 % non-linearity over a dynamic range of 5 decades.

2. BOLOMETER RESPONSE CHANGES

The bolometer can have 10 % to 20 % response changes due to drift of the quiescent temperature. Variations in the sensor temperature result from dewar vacuum degradation, change in barometric pressure, and change in background radiation incident on the detector.

The barometric pressure variation during our bolometer measurements was about 2.7 kPa (20 Torr). From the 1.4 mK/133 Pa helium boiling point change⁴ at 100 kPa, a 28 mK bolometer temperature change was determined. The barometric pressure difference between laboratories located at different altitudes can be ten times larger. The pressure dependence of the bolometer response was measured by varying the pressure in the liquid He reservoir from 100 kPa to

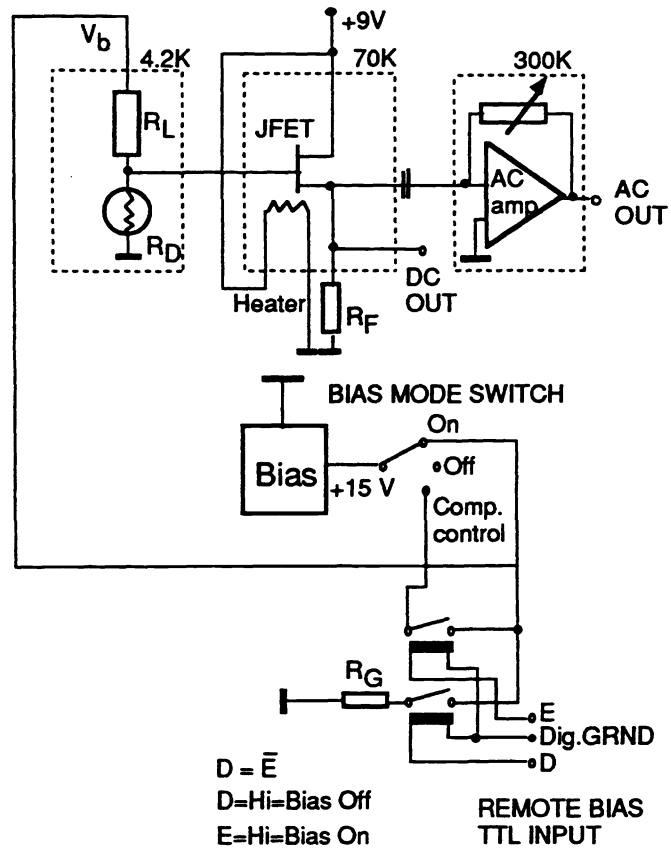

Fig. 1
Electrical scheme of the Bolometer

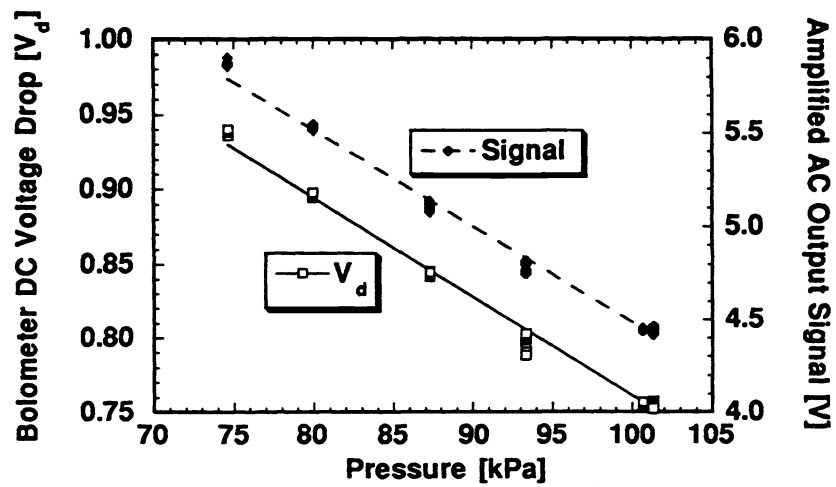

Fig. 2
Bolometer DC and amplified AC output signals vs barometric pressure

75 kPa. The amplified AC output signal and the DC voltage drop (V_d) on the sensor are shown as a function of pressure in Fig. 2. Since both functions are linear, the responsivity correction procedure is simplified.

The vacuum degradation in our dewar resulted in additional bolometer temperature changes, so modifications were made to minimize outgassing within the bolometer dewar. A carbon resistance thermometer (CRT) was used to independently monitor the temperature of the cold plate. Variations on the order of 120 mK were observed over several days. A typical variation in bolometer resistance with temperature is shown in Fig. 3. A significant contribution to the drift in V_d is due to the drift in the dewar cold plate temperature.

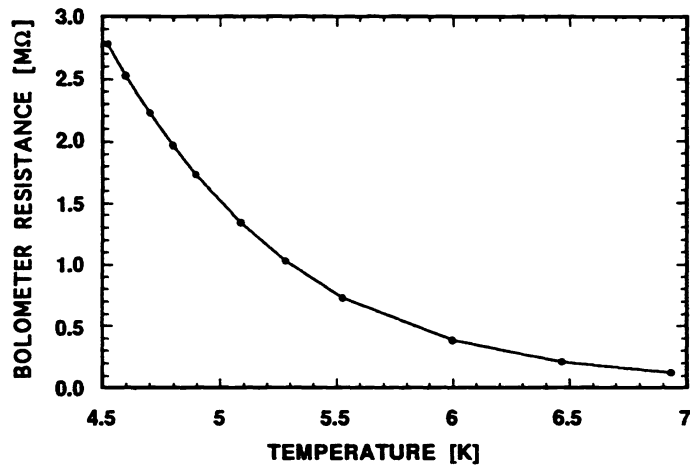

Fig. 3
Bolometer resistance vs temperature

In order to maintain a good vacuum in the dewar, cryogen refills must be done properly. A refill can be successful only if there is some liquid He remaining in the reservoir. In this case the effect of outgassing will be small. Otherwise, the dewar gets warmer and the outgassing will be large. If a warm dewar is cooled down again, without repumping the dewar, the released gases freeze out on the coldest surfaces, especially the gold-black absorber. This raises the thermal mass of the bolometer which changes the bolometer response. The response change is most pronounced if the signal chopping frequency is not much lower than the 3 dB upper roll-off point of the bolometer.

Measurements of bolometer frequency response were made over an 11 hour period. Fig. 4 shows one such measurement of the bolometer amplifier AC output signal S along with a fit to the frequency response of a single time constant low pass filter. A is the amplitude (bolometer signal response at zero frequency) and ν_0 is the 3 dB roll-off point. Fig. 5 shows the variation of A and ν_0 over that time. The amplitude fit parameter was seen to vary about 0.36% over the 11 hour measurement time.

3. BOLOMETER RESPONSE CORRECTION

As it is shown in Fig.1, the DC output signal of the bolometer is measured with the bias voltage switched on and off (either manually or by the computer). The difference between the biased and unbiased DC output voltage measurements is V_d . The offset voltage of the JFET stage is canceled out by this subtraction. Since the bolometer is generally used at an operating point V_d that is different from conditions during calibration of the bolometer, a response correction scheme is needed. It is assumed that the signal is linearly dependent on the power and V_d , hence,

$$S[P, V_d] = P (M_o + MV_d) \quad (1)$$

where M_o and M are constants. This implies that the ratio of the signals for different power levels at a fixed V_d is independent of V_d , or,

$$\frac{S[P, V_{do}]}{S[P_o, V_{do}]} = \frac{S[P, V_d]}{S[P_o, V_d]} = \frac{P}{P_o} \quad (2),$$

where V_{do} is the operating point and P_o is the optical power during calibration of the bolometer. A measurement of the bolometer output as V_d was varied is shown in Fig. 6. This measurement was made by varying the pressure in the liquid He reservoir (as in Fig 2) while maintaining constant incident radiation. The important parameter is the slope of the

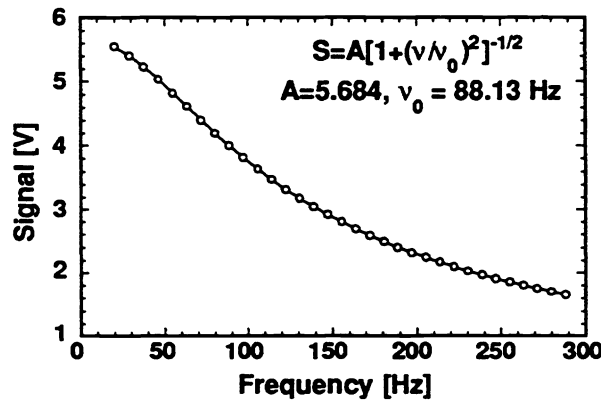

Fig. 4
Frequency dependent response of the bolometer

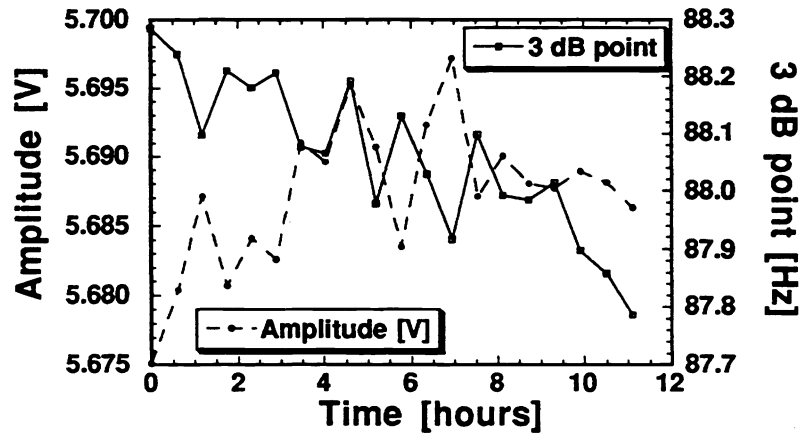

Fig. 5
Amplitude and frequency stability of the bolometer response function

curve, P_oM , and was determined to be 7.79 ± 0.02 . The intercept P_oM_o can be eliminated from equation (1) giving;

$$S[P_o, V_d] - S[P_o, V_{do}] = P_oM (V_d - V_{do}) \quad (3).$$

The unknown optical power can be calculated from equation (1) using parameters determined during calibration of the bolometer, and is given by;

$$P = \frac{P_o}{S[P_o, V_{do}]} S[P, V_{do}] \quad (4),$$

where $S[P, V_{do}]$ is the signal corrected to the bolometer operating point at calibration, and can be calculated by eliminating $S[P_o, V_d]$ from equations (2) and (3), giving the result

$$S[P, V_{do}] = \frac{S[P_o, V_{do}] S[P, V_d]}{S[P_o, V_{do}] + P_oM (V_d - V_{do})} \quad (5).$$

Substituting equation (5) into (4) gives the final calibration equation for the bolometer,

$$P = \frac{P_o}{S[P_o, V_{do}] + P_oM (V_d - V_{do})} S[P, V_d] = K S[P, V_d] \quad (6),$$

where K is the calibration coefficient, and is dependent on parameters measured during calibration, and the operating point during subsequent measurements. As a result of the response correction, the long term stability and the reproducibility of the bolometer, as shown in Fig. 7, was within $\pm 0.25\%$.

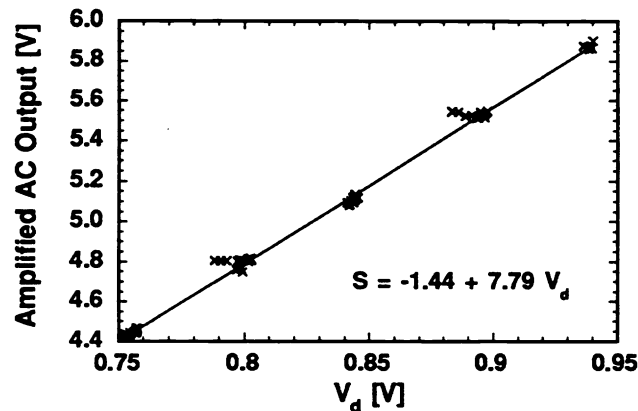

Fig. 6
Amplified AC output signal vs DC output signal

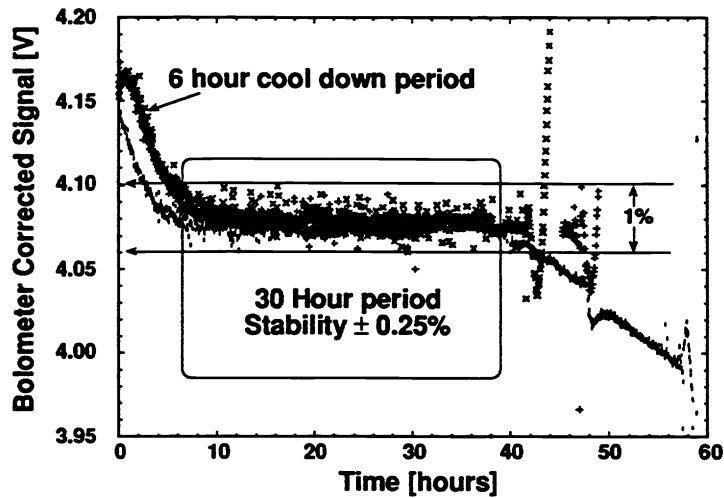

Fig. 7
Repeatability of the bolometer response

4. SPATIAL RESPONSE UNIFORMITY

Fig. 8 shows the AC output signal (a spatial response scan) along the horizontal diameter of the bolometer aperture, with the monochromator set to a wavelength of 5 μm . The monochromator output was focused onto the bolometer aperture. From the curve shape a 1.3 mm beam-diameter (FWHM) was estimated. The response variation in the 2 mm long central region is within 1 %.

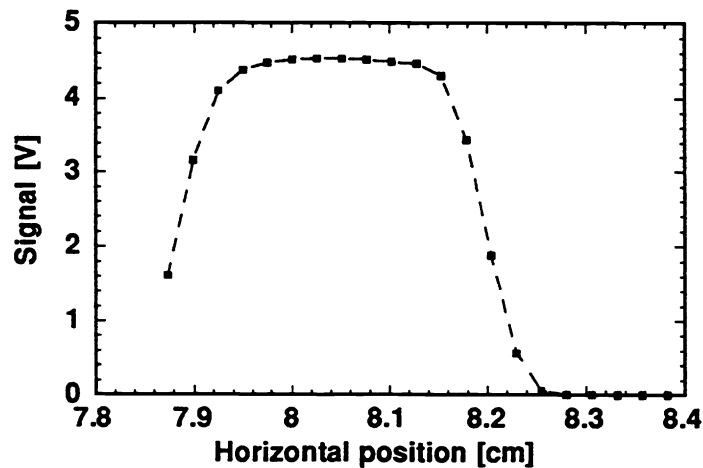

Fig. 8
Spatial response change along the horizontal diameter of the bolometer

5. BOLOMETER ABSOLUTE RESPONSE CALIBRATION

The calibration of the transfer standard cryogenic bolometer will be linked to the NIST High Accuracy Cryogenic Radiometer (HACR) ^{5,6} at a few laser wavelengths. The HACR is an electrical substitution radiometer that serves as the primary standard for optical power measurements and has been used to measure optical power at visible wavelengths with a relative standard uncertainty⁷ of 0.021 %. Because the highest accuracy with the HACR requires an optical power level approaching 1 mW, while the response of the bolometer becomes nonlinear at power levels above 4 μ W, indirect calibrations were performed.

At 632.8 nm a silicon photodiode light-trapping detector was calibrated against the HACR, and then the bolometer was calibrated against the trap detector.

In the infrared wavelength range, a pyroelectric detector was selected as a calibration transfer between the HACR and the bolometer. The dynamic range of the pyroelectric detector is suitable for bridging the range between 4 μ W and 1 mW. The detector used is part of a commercial electrically calibrated pyroelectric radiometer (ECPR), but can also be operated without electrical substitution. Since the two modes of operation have different potential systematic errors, we are calibrating this device in both modes of operation, which provides a check on these systematics.

The laser source for the infrared HACR calibrations is a grating-tuned CO₂ laser. A laser stabilizer maintains the optical power to within about 0.1% over the course of an hour. The beam is prepared in a similar fashion as is used for measurements at visible wavelength.^{5,6} By orienting a ZnSe entrance window of the HACR at Brewster's angle, the reflection of the polarized laser light from the window is reduced to below 0.04%. The pyroelectric detector is mounted on a motor-driven carousel and can be rotated into position just before the entrance window of the HACR. The optical beam is chopped at 40 Hz which is equal to the chopping frequency selected for the bolometer. The output of the pyroelectric detector is amplified and then sent to a lock-in amplifier; the output of the lock-in is measured by a digital voltmeter. Because the HACR has a four minute time constant, it only responds to the average power in the chopped beam. (The exact ratio of the power in the chopped beam to the power incident on the chopper is measured separately.)

Two corrections that must be applied to the measurement of optical power by the HACR are the transmittance of the entrance window and the quantity of scattered laser light. Scattered laser light refers to light that is incident upon the detector to be calibrated, but scattered out of the field of view of the absorbing cavity in the HACR. For measurements at visible wavelengths, the dominant component of the 0.021% relative standard uncertainty in optical power measurements with the HACR is due to the transmittance of the entrance window. For visible wavelengths, there is little scattered laser light, and it is measured by annular silicon photodiodes located along the optical path within the HACR. For infrared wavelengths the scattered laser light cannot be measured with the photodiodes in the HACR, so the scattered light was characterized with the beam redirected outside the HACR. Based on preliminary measurements, we expect the corrections from window transmittance and scatter to be each about a few tenths of a percent of the incident laser power. An additional uncertainty is the spatial non-uniformity of the pyroelectric detector, which for visible wavelengths is about ± 2 %. Tests are underway to determine the non-uniformity at 10.6 μ m.

The typical Type A relative standard uncertainty in HACR measurements is 0.01 % at visible wavelengths and an optical power level of 0.8 mW. Because the stability of the optical power in the CO₂ laser beam is not as good as the stability achievable with visible lasers, this Type A uncertainty is expected to be higher. However, preliminary measurements indicate that this component of uncertainty will not exceed 0.1%.

We have performed a preliminary calibration of the pyroelectric detector with the HACR at a wavelength of 10.6 μ m. As an initial check on this calibration, we also calibrated the pyroelectric detector at 632.8 nm and used the manufacturer's data for the spectral reflectance of the black coating on the pyroelectric detector to predict the expected responsivity at 10.6 μ m. (The calibration at 632.8 nm was performed using a silicon trap detector that had been previously calibrated against the HACR.) The measured responsivity, as determined by the direct calibration against the HACR, was within 1% of this predicted value. We are improving the direct calibration of the pyroelectric detector against the HACR at 10.6 μ m and expect to obtain a relative standard uncertainty of 0.5% or better, in both modes of operation.

Using the output beam of the detector comparator as a source, a preliminary calibration of the bolometer against the pyroelectric detector was made at 10.6 μm . Because the available power at this wavelength was only 0.5 μW , the signal to noise ratio was less than 10:1, and the relative standard uncertainty of this calibration was $\pm 11\%$.

6. BOLOMETER SPECTRAL RESPONSE CALIBRATION

The bolometer relative spectral response was determined from measurements of the spectral reflectance of the bolometer, R, and the window transmittance T. Fig. 9 shows the bolometer spectral reflectance measured on a Fourier Transform Infrared Spectrometer (FTIR). The small slope determined by the linear fit shows the relative flatness of the

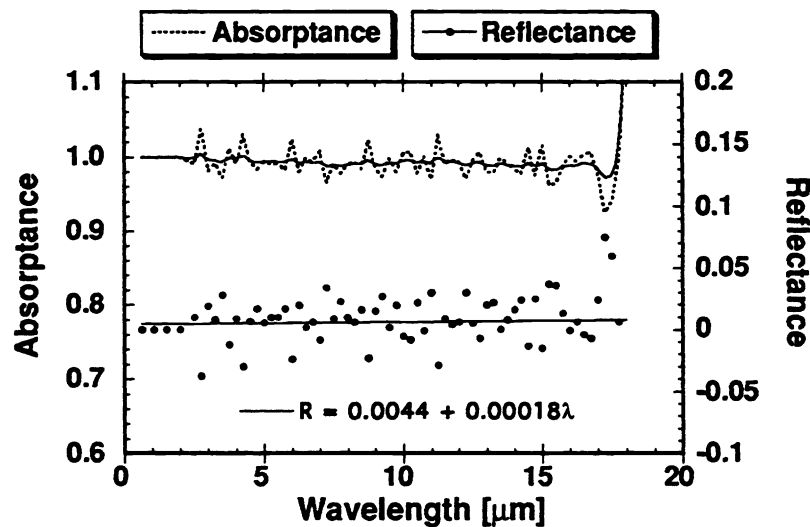

Fig. 9
Spectral reflectance and absorption of the bolometer

reflectance vs. wavelength. The low signal to noise ratio in the FTIR measurements limits the long wavelength end of the measurement to 18 μm . The spectral absorbance A is given by $A=1-R$. It is assumed that the transmittance of the gold-black is negligible.

The spectral transmittance measurements of the KRS-5 bolometer window are shown in Fig. 10. These measurements were made using the bolometer and detector comparator with the window under test moved in and out of the beam. Several spectral scans were averaged in each of the four wavelength intervals of the 2 μm to 19 μm spectral range, with the error bars representing the type A standard uncertainty. These transmittance values were fit to a fourth order polynomial. The wavelength range was limited at 19 μm due to low signal to noise.

Three laser transmittance measurements were done at wavelengths of 632.8 nm, 1.06 μm , and 1.52 μm . The first and third measurements were made using the bolometer at a power level of about 3 μW . The 1.06 μm measurement was made with a silicon detector at about 1 mW. The uncertainty of these laser measurements was 0.24 %.

The spectral response of the bolometer is shown in Fig. 11. The Y scale on the left is the bolometer optical efficiency (the product of the bolometer absorption (Fig. 9) and the spectral window transmittance (Fig. 10)). The Y

scale on the right is the absolute bolometer response at an AC amplifier gain of 100 V/V. The response is tied to the absolute scale at 632.8 nm. A fifth order polynomial fit was used to smooth the reflectance results in Fig. 11. The preliminary measurement of the bolometer response at 10.6 μm is also shown in Fig. 11. The largest contribution to the $\pm 11\%$ uncertainty in this preliminary measurement was the signal to noise ratio (less than 10:1) of the pyroelectric detector in the (0.5 μW) output beam of the monochromator.

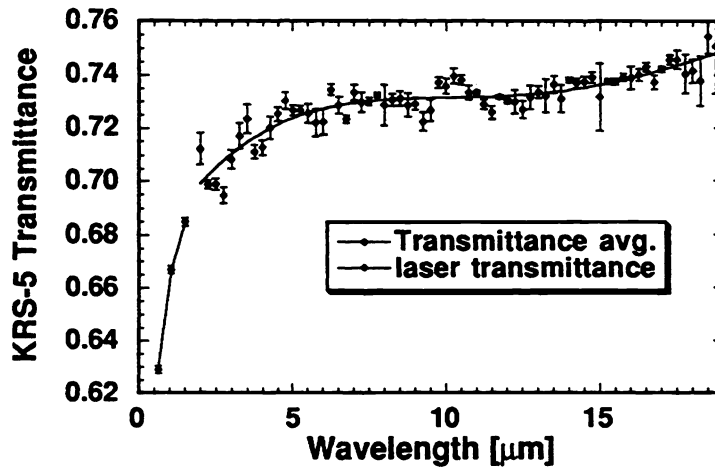

Fig. 10
Spectral transmittance of the KRS-5 bolometer window

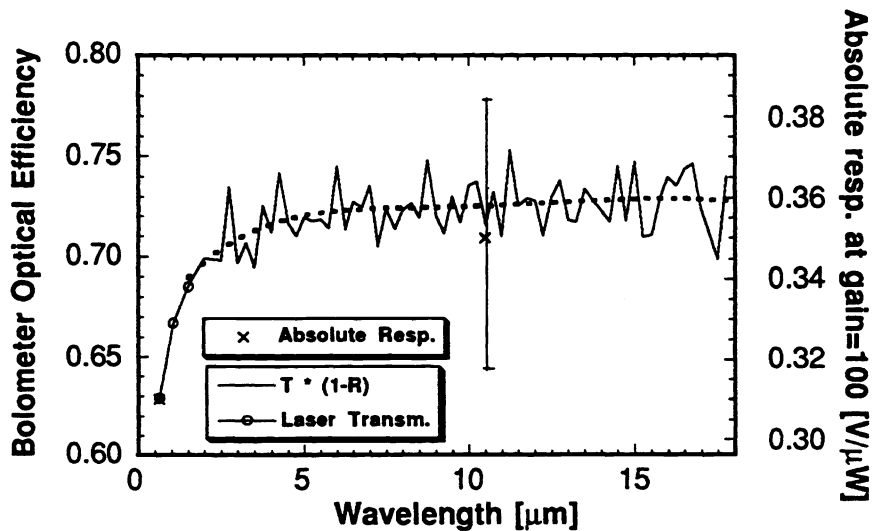

Fig. 11
Bolometer spectral response

7. ERROR BUDGET OF BOLOMETER RESPONSE

The error budget was estimated for the 632.8 nm absolute calibration point and the spectral response calibration based on the 632.8 nm reference point. The sources of uncertainty are shown in Table 1.

Table 1
Error budget for absolute spectral response calibration of cryogenic bolometer

Uncertainty origin	Relative standard uncertainty [%]	
	Type A	Type B
1. At the 632.8 nm calibration point:		
Absolute responsivity of silicon trap detector ⁸		0.11
Response corrections	0.18	
Spatial response non-uniformity		1.0
Non-linearity below 4 μ W		0.5
Response change/hour from 3 dB point variation	0.03	
Laser power stability from monitor detector	0.05	
	0.19	1.12
Combined standard uncertainty	1.14	
2. For the spectral range between 1 μ m and 18 μ m:		
KRS-5 spectral transmittance measurement	0.7	1.0
Bolometer spectral reflectance variation	1.0	
Background noise	0.02	
Lock-in amplifier/electronics nonlinearity		0.05
	1.22	1.52
Combined standard uncertainty	1.95	
Expanded uncertainty (k=2)	3.9	

8. CONCLUSIONS

The infrared detector calibration facility at NIST is used to measure absolute spectral response of infrared detectors using a cryogenic bolometer as the reference standard. The bolometer has been characterized, and the relative spectral response measured between 632.8 nm and 18 μ m. The absolute spectral response calibration of the bolometer was measured using a pyroelectric and silicon trap detector at a laser wavelength of 632.8 nm traceable to the NIST high accuracy cryogenic radiometer. The estimated expanded uncertainty of the bolometer absolute spectral response is 3.9 %.

A preliminary calibration of the pyroelectric detector against the HACR at 10.6 μ m agreed with the expected responsivity to within 1%. Work is in progress to perform this calibration with an uncertainty of 0.5 % or better.

A preliminary bolometer absolute response measurement has been performed at 10.6 μ m with the transfer standard pyroelectric detector calibrated against the HACR. At present the output power from the monochromator at 10.6 μ m is 0.5 μ W, and the signal to noise ratio of the pyroelectric detector was less than 10:1 at this power level. We plan

to repeat the calibration of the bolometer with the pyroelectric detector using a 4 μ W attenuated beam from the CO₂ laser.

9. ACKNOWLEDGEMENTS

We thank L. M. Hanssen and Z. M. Zhang for their help in measuring the reflectance of the gold black coatings. We also thank S. R. Lorentz and J. H. Walker for their help with bolometer resistance measurements.

10. REFERENCES

1. A.L. Migdall, G.P. Eppeldauer, and C.L. Cromer, "IR Detector Spectral Responsivity Calibration Facility at NIST," *SPIE Proc.* Vol. 2227, pp. 46-53, 1994.
2. G. Eppeldauer, A.L. Migdall, and C.L. Cromer, "Characterization of a High Sensitivity Composite Silicon Bolometer," *Metrologia*, Vol. 30, pp. 317-320, 1993.
3. G. Eppeldauer, A.L. Migdall, and C.L. Cromer, "A Cryogenic Silicon Resistance Bolometer for Use as An Infrared Transfer Standard Detector," in *Thermal Phenomena at Molecular and in Cryogenic Infrared Detectors*, HTD-Vol. 277, pp. 63-67, 1994.
4. G. K. White, *Experimental Techniques in Low-Temperature Physics*, Third Edition, pp. 307, Clarendon Press, Oxford, 1987.
5. J.M. Houston, C.L. Cromer, J.E. Hardis, and T.C. Larason, "Comparison of the NIST High Accuracy Cryogenic Radiometer and the NIST Scale of Detector Spectral Response," *Metrologia*, Vol. 30, pp. 285-290, 1993.
6. T. R. Gentile, J. M. Houston, J. E. Hardis, C. L. Cromer and A. C. Parr, "The NIST High Accuracy Cryogenic Radiometer", submitted to *Appl. Opt.*
7. B.N. Taylor and C.E. Kuyatt, "Guidelines for evaluating and expressing the uncertainty of NIST measurement results," *NIST Technical Note* 1297 (1994 edition).
8. C. L. Cromer, "A New Spectral Response Calibration Method using a Silicon Photodiode Trap Detector," in *Proceedings of Measurement Science Conference*, Jan 31-Feb 1, 1991, Anaheim, CA.